



US00D744829S

(12) **United States Design Patent**
Deering et al.

(10) **Patent No.:** **US D744,829 S**

(45) **Date of Patent:** **** Dec. 8, 2015**

(54) **END LOAD CARTON WITH CLOSURE SYSTEM**

(71) Applicant: **General Mills, Inc.**, Minneapolis, MN (US)

(72) Inventors: **Curtis J Deering**, Eden Prairie, MN (US); **Elizabeth Nordstrum**, Sunnyvale, CA (US); **Felicia A Pinkstone**, Aston, PA (US)

(73) Assignee: **General Mill, Inc.**, Minneapolis, MN (US)

(**) Term: **14 Years**

(21) Appl. No.: **29/491,048**

(22) Filed: **May 16, 2014**

(51) **LOC (10) Cl.** **09-03**

(52) **U.S. Cl.**
USPC **D9/432**

(58) **Field of Classification Search**

USPC D9/414-419, 420-425, 428, 429-435, D9/600, 652, 667-679, 708, 719, 734; D3/203.2, 272, 273, 294, 302-304; D7/538-542, 601, 602, 629
CPC B65D 5/18; B65D 5/20; B65D 5/24; B65D 5/28; B65D 5/30; B65D 5/42; B65D 5/46; B65D 5/70; B65D 5/74; B65D 5/546; B65D 5/2038; B65D 5/2052; B65D 5/48022; B65D 5/665; B65D 25/00; B65D 85/00
See application file for complete search history.

(56) **References Cited**

U.S. PATENT DOCUMENTS

882,688 A 3/1908 Janicke
2,151,202 A 3/1939 Guyer
2,162,556 A 6/1939 Lagaard

3,201,026 A 8/1965 Travis et al.
3,542,281 A * 11/1970 Field et al. 383/21
3,549,082 A 12/1970 Simpson
3,797,728 A 3/1974 Buttery et al.
4,308,995 A * 1/1982 Hanes 229/117.15
4,583,681 A * 4/1986 Neese 229/117.22

(Continued)

FOREIGN PATENT DOCUMENTS

DE 202005010894 9/2005
EP 743256 11/1996

(Continued)

Primary Examiner — Susan Bennett Hattan

Assistant Examiner — Vy Koenig

(74) *Attorney, Agent, or Firm* — Diederiks & Whitelaw, PLC; Gregory P. Kaihoi

(57) **CLAIM**

The ornamental design for an end load carton with closure system, as shown and described.

DESCRIPTION

FIG. 1 is an upper perspective view of an end load carton with a closure system according to our new design;
FIG. 2 is a top plan view of the end load carton of FIG. 1 with the closure system in an initial closed condition with an upper flap of the carton sealed to a lower flap;
FIG. 3 is a bottom plan view of the end load carton of FIG. 1;
FIG. 4 is an elevational view of a main panel of the end load carton of FIG. 1;
FIG. 5 is an elevational view of an opposing main panel of the end load carton of FIG. 1;
FIG. 6 is an elevational view of one side panel of the end load carton of FIG. 1, with an opposing side panel view being a mirror image thereof; and,
FIG. 7 is a top plan view of the end load carton similar to FIG. 2 but with the closure system in a re-closed condition.

1 Claim, 6 Drawing Sheets

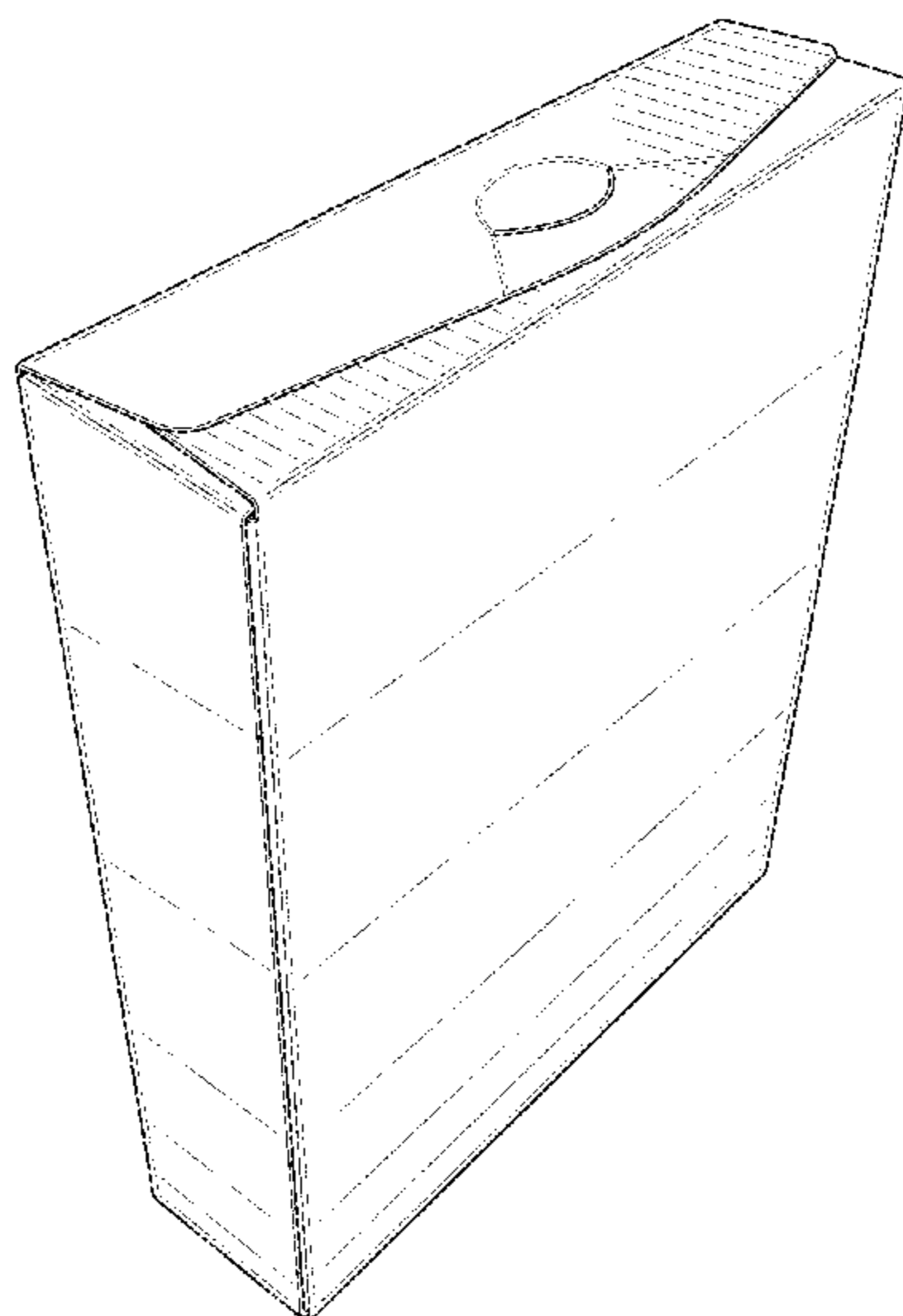

(56)

References Cited

2012/0031959 A1 2/2012 Emmott

U.S. PATENT DOCUMENTS

FOREIGN PATENT DOCUMENTS

4,718,557 A 1/1988 Friedman
4,746,052 A 5/1988 Schmissrauter
5,755,377 A 5/1998 Durand
D396,805 S * 8/1998 Broyles D9/432
6,206,280 B1 3/2001 Thresher et al.
6,695,144 B2 2/2004 Freeze
D548,590 S * 8/2007 Forthaus et al. D9/432
D558,573 S * 1/2008 Forthaus et al. D9/433
8,408,451 B2 4/2013 Adam et al.
8,459,538 B2 6/2013 Raeth et al.

GB 1381847 8/1972
JP 8134406 5/1996
JP 11139427 5/1999
JP 11198927 7/1999
JP 2006206183 8/2006
JP 2009154955 7/2009
JP 2013-136395 7/2013

* cited by examiner

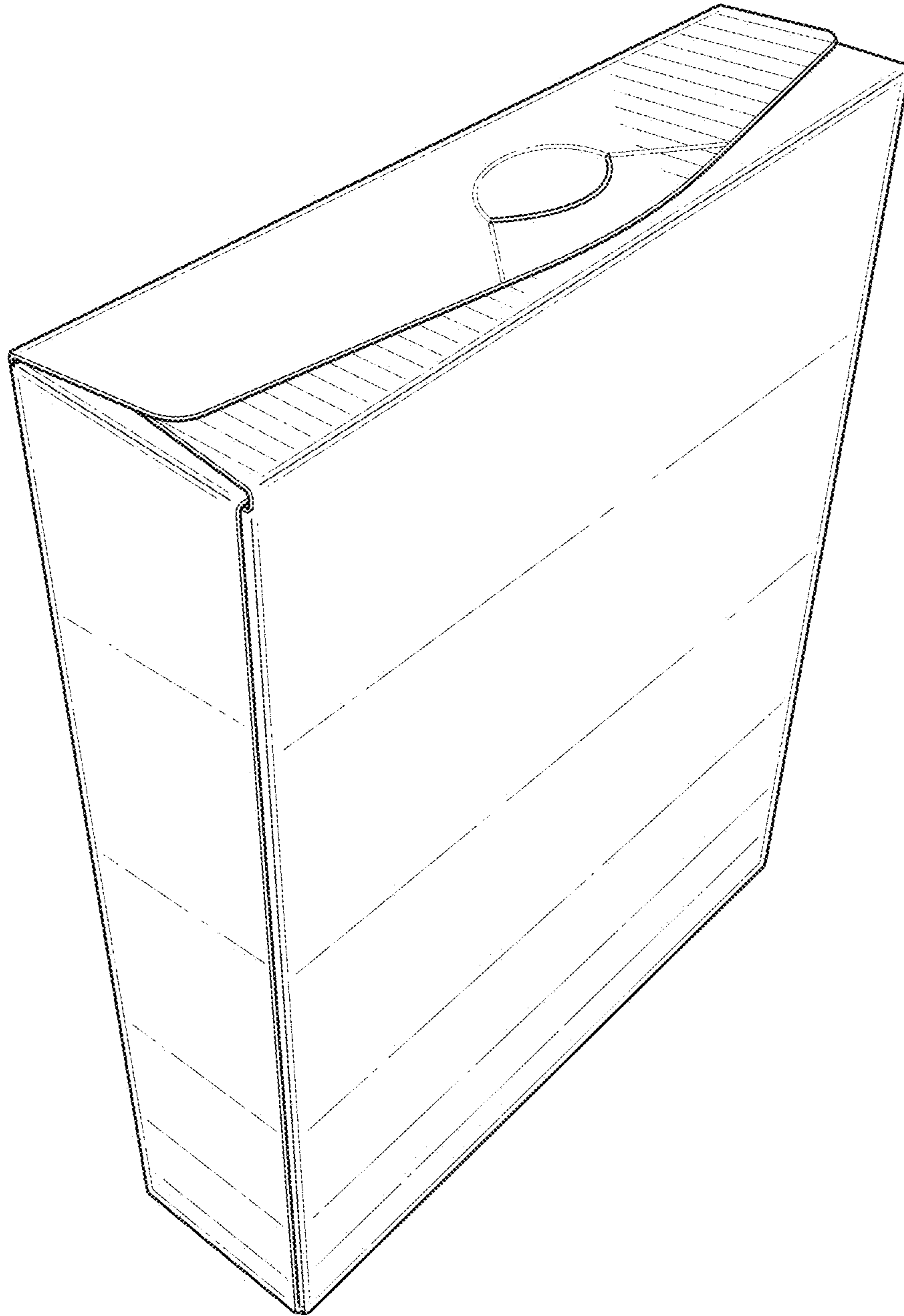

FIG. 1

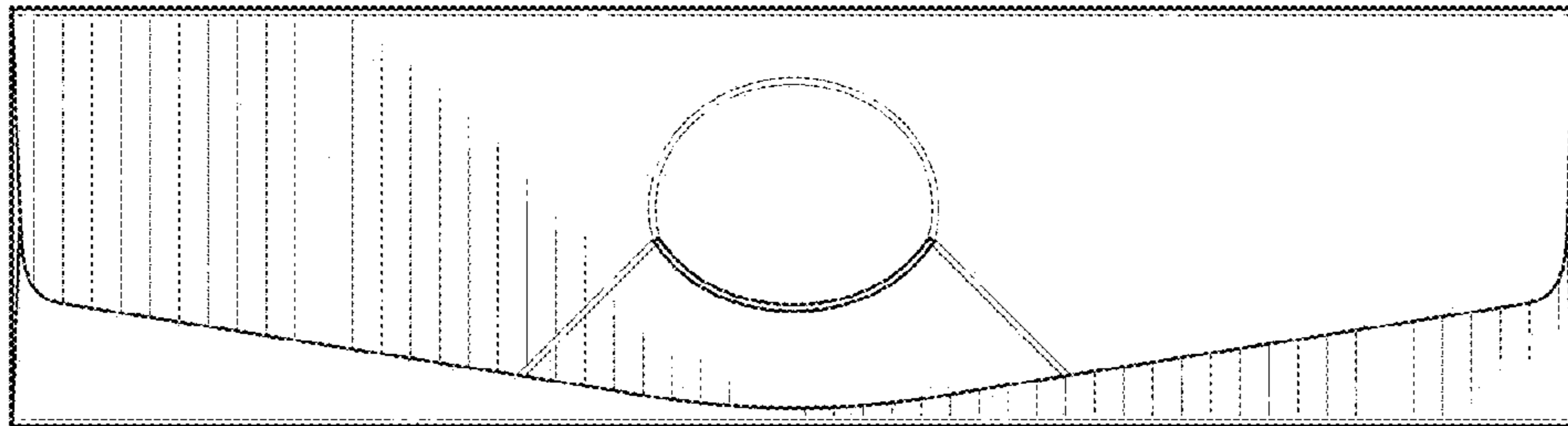

FIG. 2

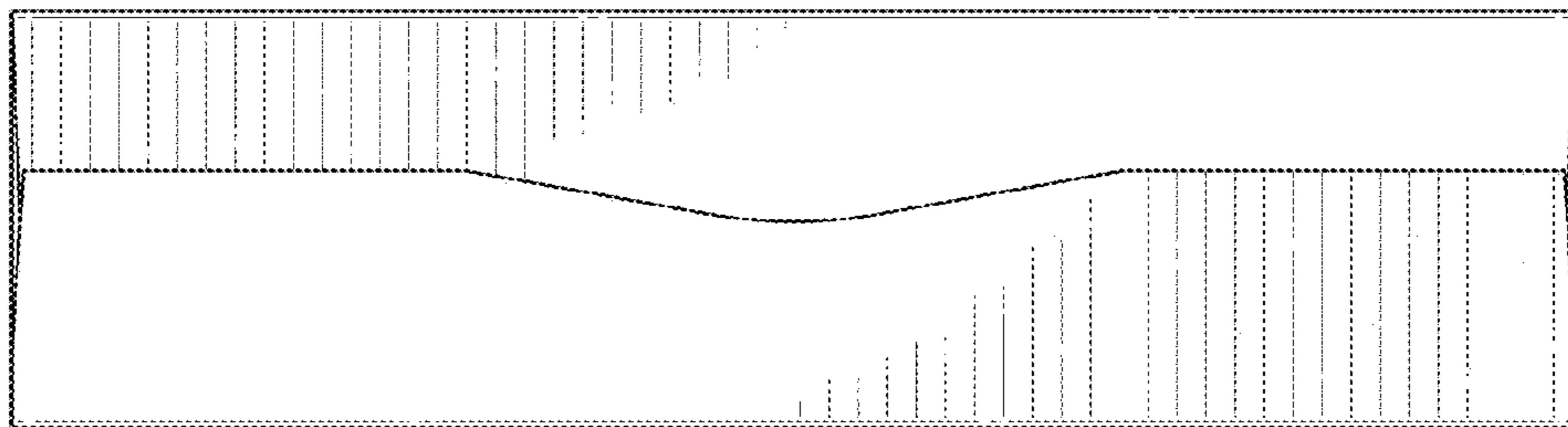

FIG. 3

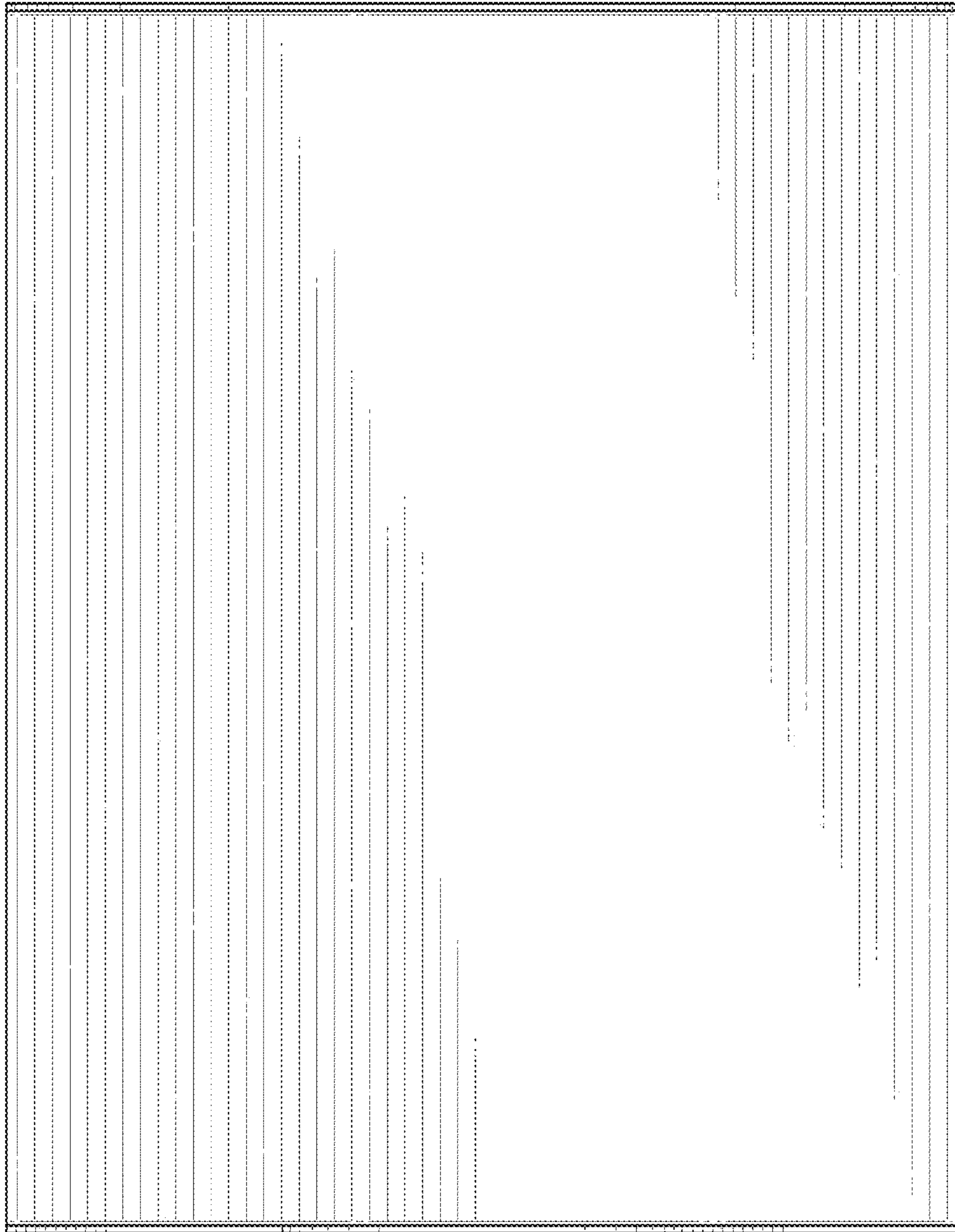

FIG. 4

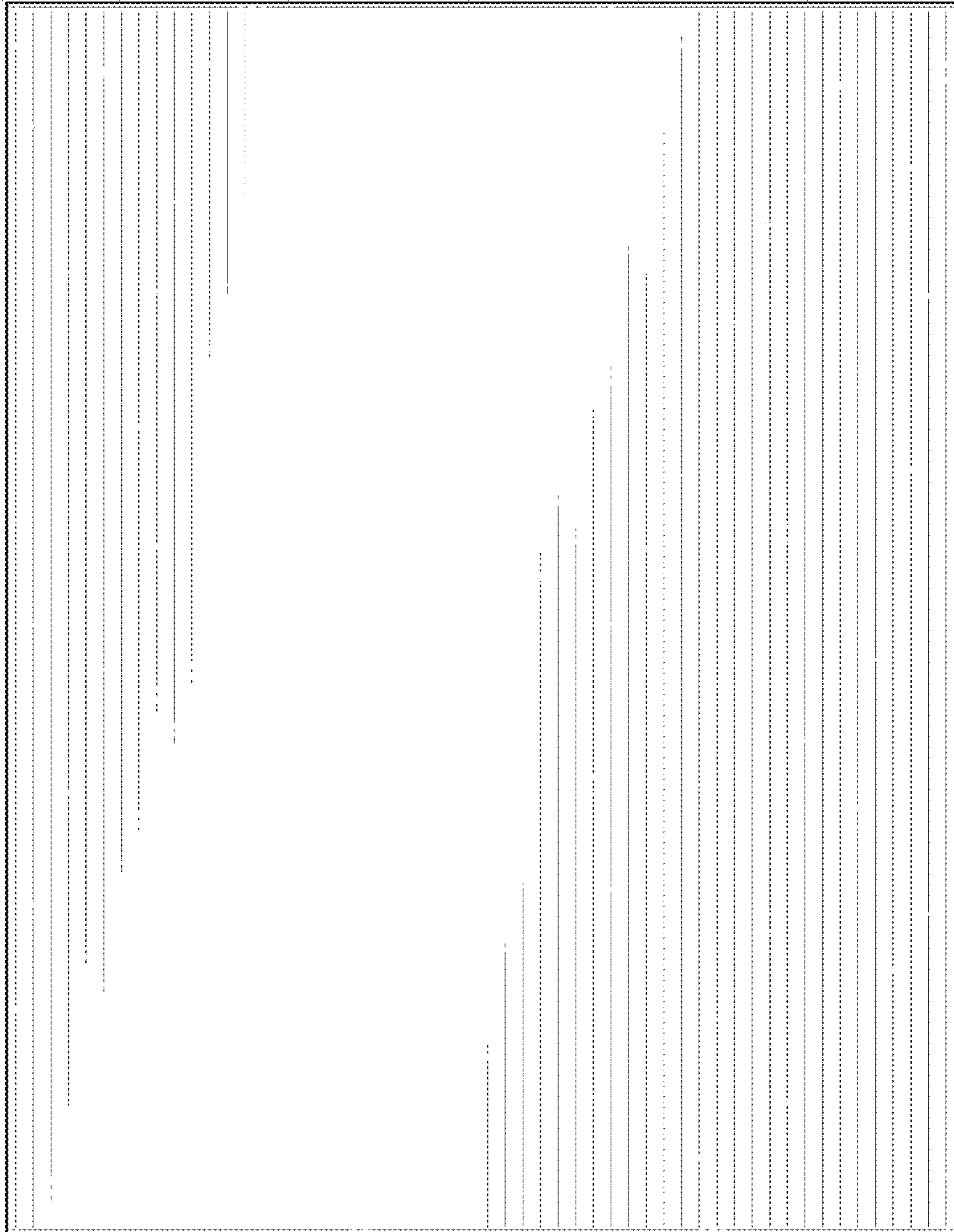

FIG. 5

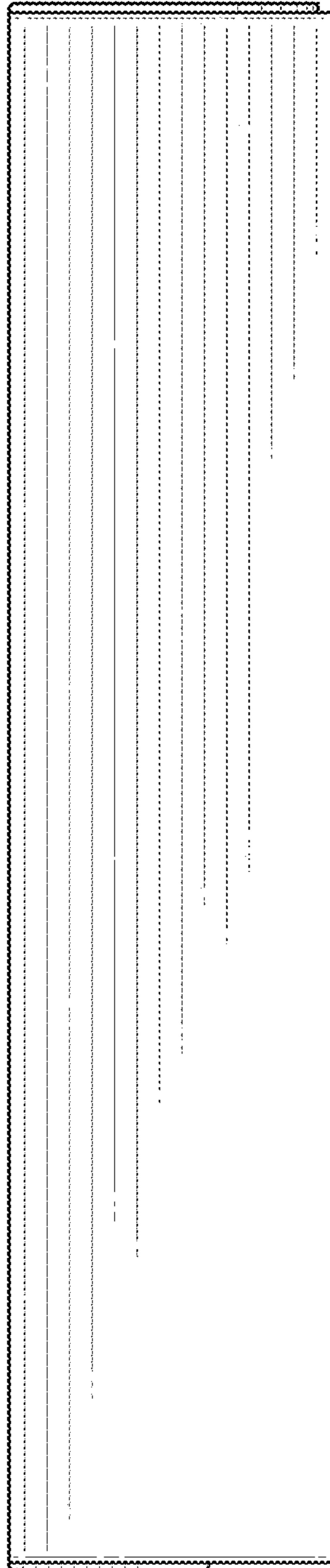

FIG. 6

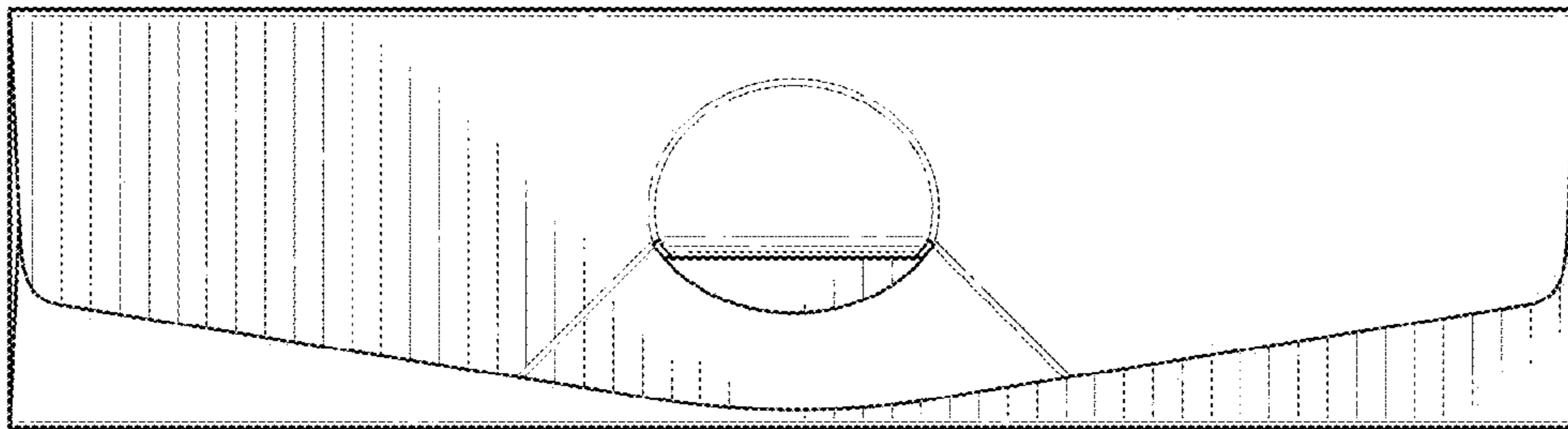

FIG. 7