



US00D744795S

(12) **United States Design Patent**
Robinson et al.

(10) **Patent No.:** **US D744,795 S**
(45) **Date of Patent:** **** Dec. 8, 2015**

(54) **WRENCH**

(71) Applicants: **Glenn Robinson**, Parkland, FL (US);
Allan Ospina, Hallandale Beach, FL
(US)

(72) Inventors: **Glenn Robinson**, Parkland, FL (US);
Allan Ospina, Hallandale Beach, FL
(US)

(**) Term: **14 Years**

(21) Appl. No.: **29/474,106**

(22) Filed: **Jun. 2, 2014**

(51) **LOC (10) Cl.** **08-05**

(52) **U.S. Cl.**
USPC **D8/22**

(58) **Field of Classification Search**
USPC D8/22, 55; 81/111, 126, 124.5, 129.5,
81/117, 133, 155, 165-170
CPC B25B 13/00; B25B 13/10
See application file for complete search history.

(56) **References Cited**

U.S. PATENT DOCUMENTS

D326,038	S	*	5/1992	Murayama	D8/22
6,257,101	B1	*	7/2001	Marlette et al.	81/165
D461,381	S	*	8/2002	Kramer	D8/22
D463,233	S	*	9/2002	Salazar et al.	D8/22
D548,553	S	*	8/2007	Hsieh	D8/22
D681,409	S	*	5/2013	Macor	D8/22
D696,565	S	*	12/2013	Huang	D8/22

* cited by examiner

Primary Examiner — Randall Gholson
(74) *Attorney, Agent, or Firm* — Dan M. DeLa Rosa

(57) **CLAIM**

The ornamental design for a wrench, as shown and described.

DESCRIPTION

FIG. 1 is a front perspective view of the wrench of the present invention showing my new design;
FIG. 2 is a front side elevational view thereof;
FIG. 3 is a back side elevational view thereof;
FIG. 4 is a side elevational view thereof;
FIG. 5 is another side elevational view thereof;
FIG. 6 is a top plan view thereof; and,
FIG. 7 is a bottom plan view thereof.
The broken lines depict portions of the wrench that form no part of the claimed design.

1 Claim, 5 Drawing Sheets

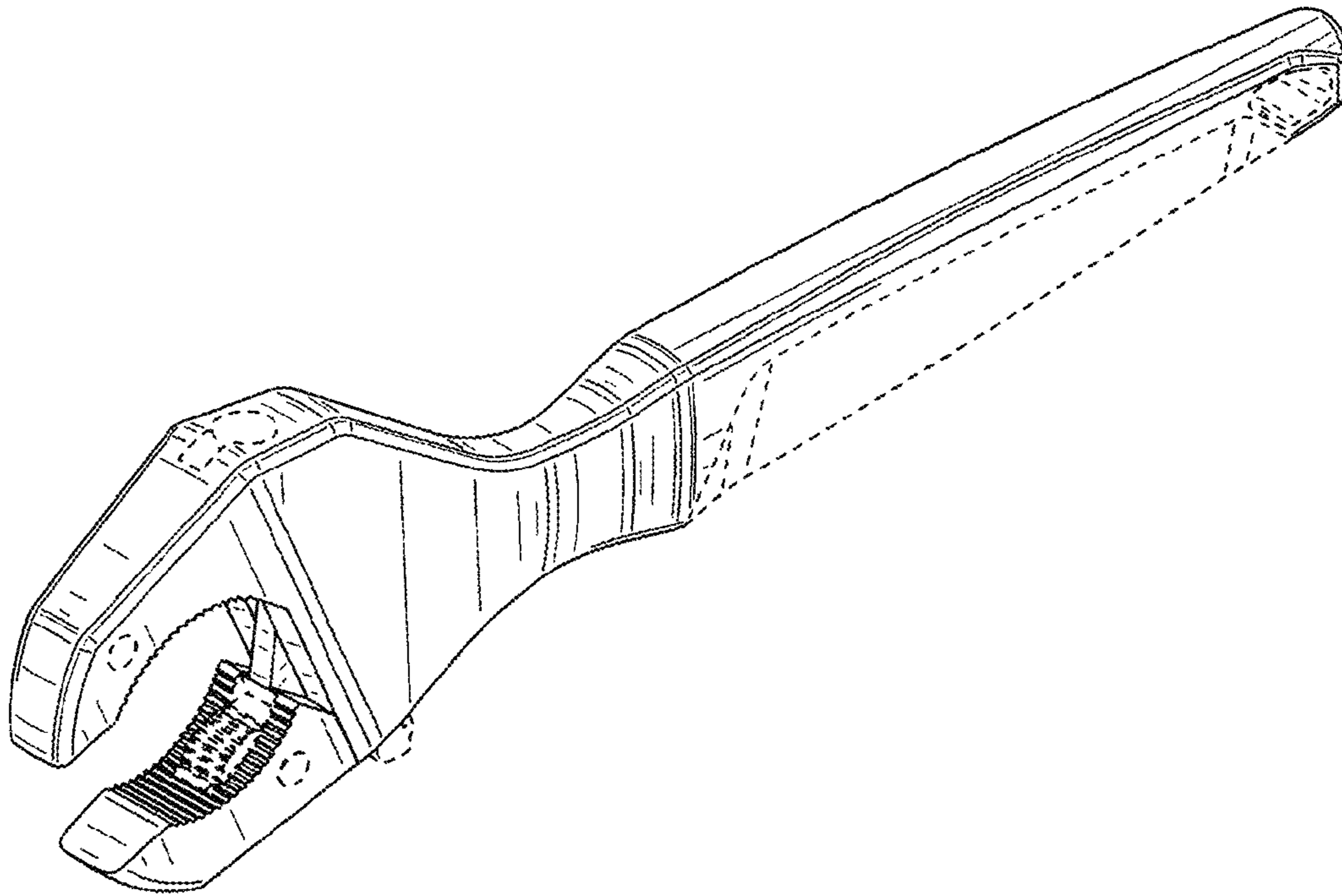

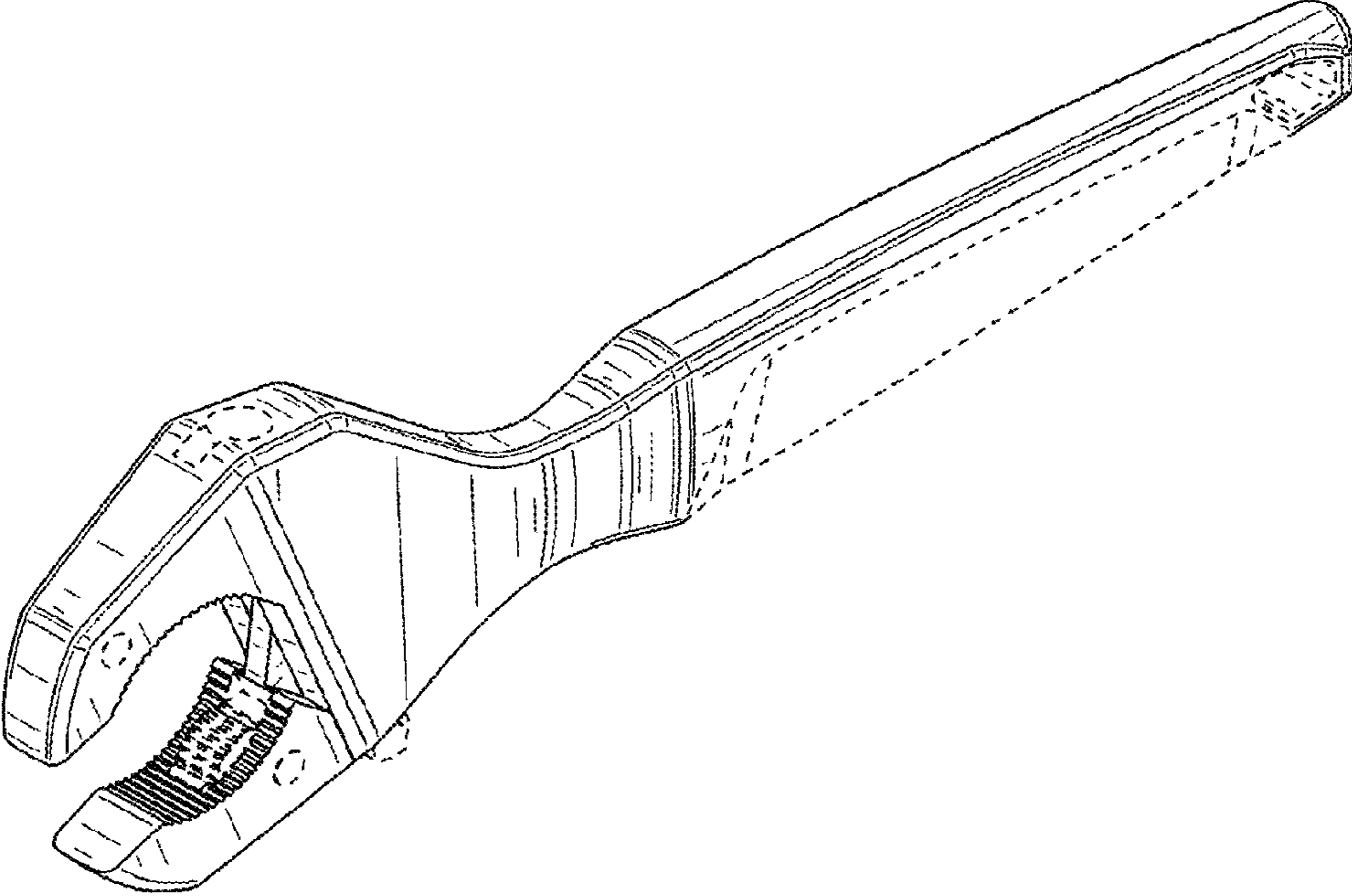

FIG. 1

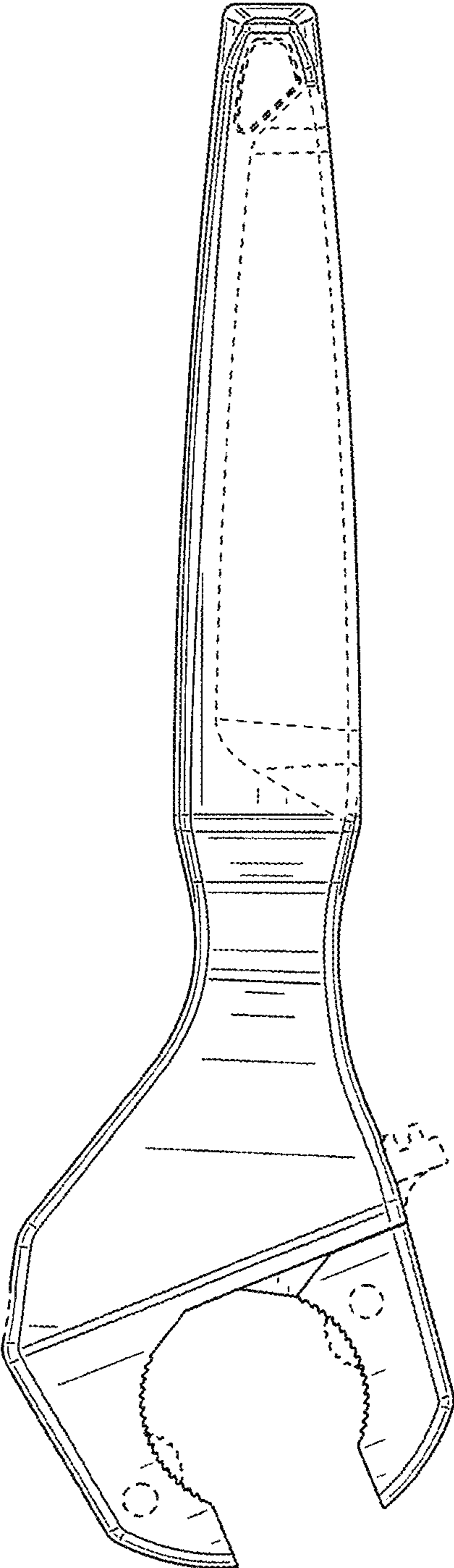

FIG. 2

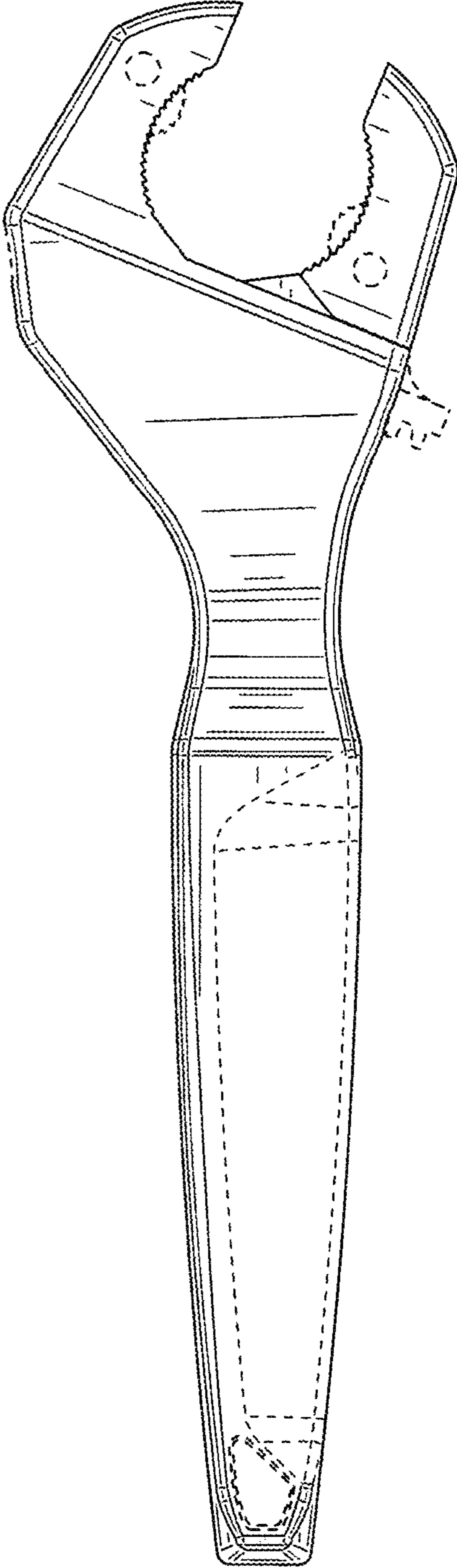

FIG. 3

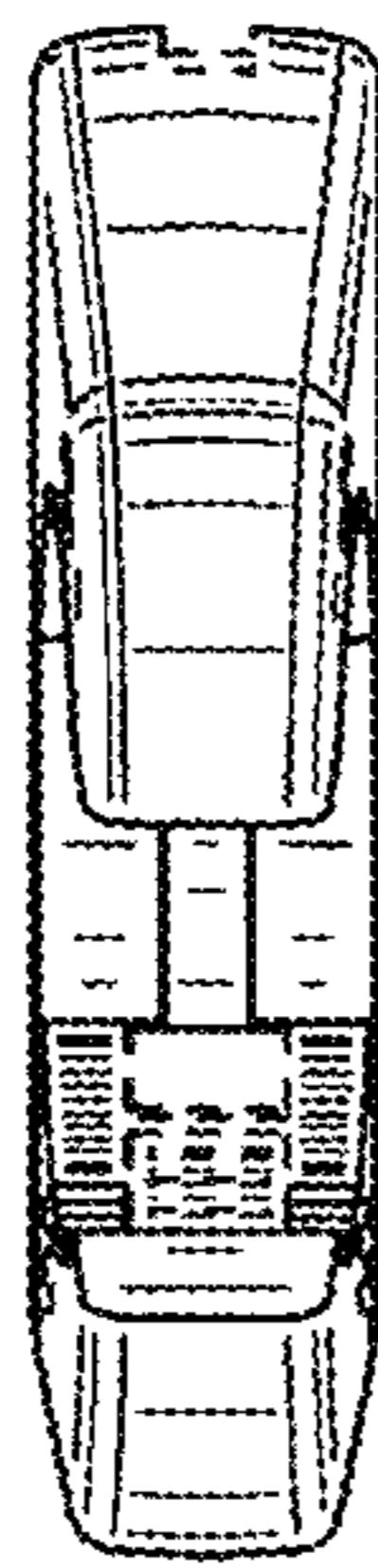

FIG. 4

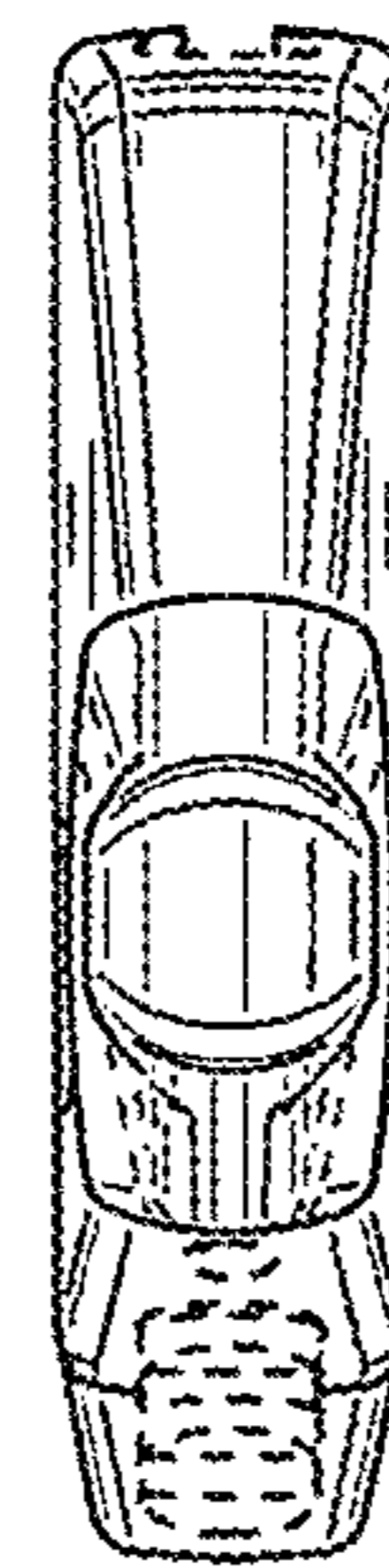

FIG. 5

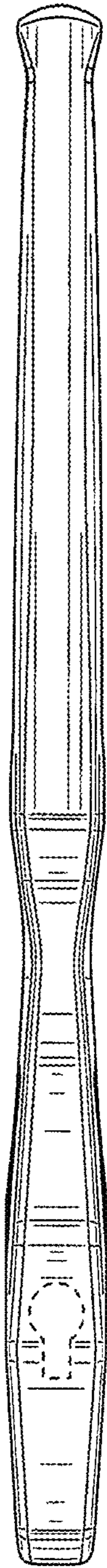

FIG. 6

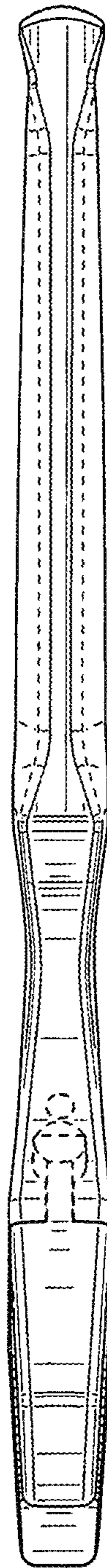

FIG. 7