



US00D744455S

(12) **United States Design Patent**
Huang

(10) **Patent No.:** **US D744,455 S**
(45) **Date of Patent:** **** Dec. 1, 2015**

(54) **VIBRATION UNIT FOR ACOUSTIC MODULE**

(71) Applicant: **Tang Band Industries Co., Ltd.,**
Ningbo (CN)

(72) Inventor: **Hsin Min Huang,** Ningbo (CN)

(73) Assignee: **Tang Band Industries Co., Ltd.,**
Ningbo, Zhejiang (CN)

(**) Term: **14 Years**

(21) Appl. No.: **29/488,389**

(22) Filed: **Apr. 18, 2014**

(51) **LOC (10) Cl.** **14-01**

(52) **U.S. Cl.**
USPC **D14/222; D14/204**

(58) **Field of Classification Search**
USPC D14/204, 210–216, 221, 222, 172;
181/143, 144, 147, 148, 150–153, 157,
181/198, 199; 381/300–303, 306, 332, 333,
381/336, 345, 361–364, 386–388
CPC H04R 7/00; H04R 7/045
See application file for complete search history.

(56) **References Cited**

U.S. PATENT DOCUMENTS

4,965,837 A * 10/1990 Murayama et al. 381/186
5,455,396 A * 10/1995 Willard et al. 181/172

D421,263 S * 2/2000 Phillips D14/222
D473,216 S * 4/2003 Irby et al. D14/222
D650,367 S * 12/2011 Chen D14/222
8,237,377 B2 * 8/2012 Hopper 315/294
D682,810 S * 5/2013 Chen D14/222
D705,756 S * 5/2014 Kerstein et al. D14/222
D723,010 S * 2/2015 Moon et al. D14/222
8,965,009 B2 * 2/2015 Kim et al. 381/117

* cited by examiner

Primary Examiner — Prabhakar Deshmukh

(74) *Attorney, Agent, or Firm* — Raymond Y. Chan; David
and Raymond Patent Firm

(57) **CLAIM**

The ornamental design for a vibration unit for acoustic mod-
ule, as shown and described.

DESCRIPTION

FIG. 1 is a perspective view of a vibration unit for acoustic
module showing my new design.

FIG. 2 is a top plan view thereof.

FIG. 3 is a bottom plan view thereof, wherein the broken line
portion of the figure drawing is included to show unclaimed
subjected matter only and forms no part of the claimed
design.

FIG. 4 is a left side elevational view thereof.

FIG. 5 is a right side elevational view thereof.

FIG. 6 is a front elevational view thereof; and,

FIG. 7 is a rear elevational view thereof.

1 Claim, 5 Drawing Sheets

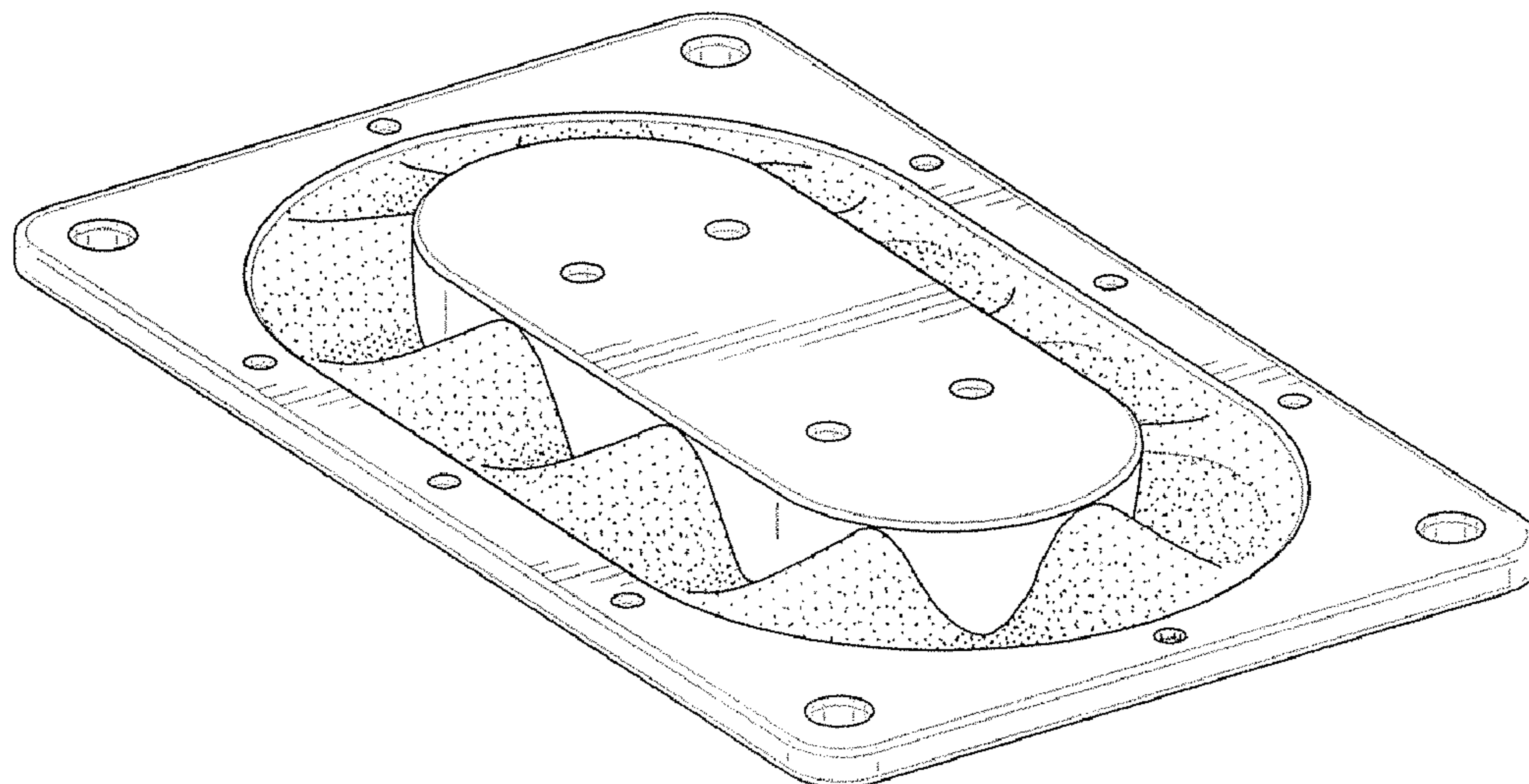

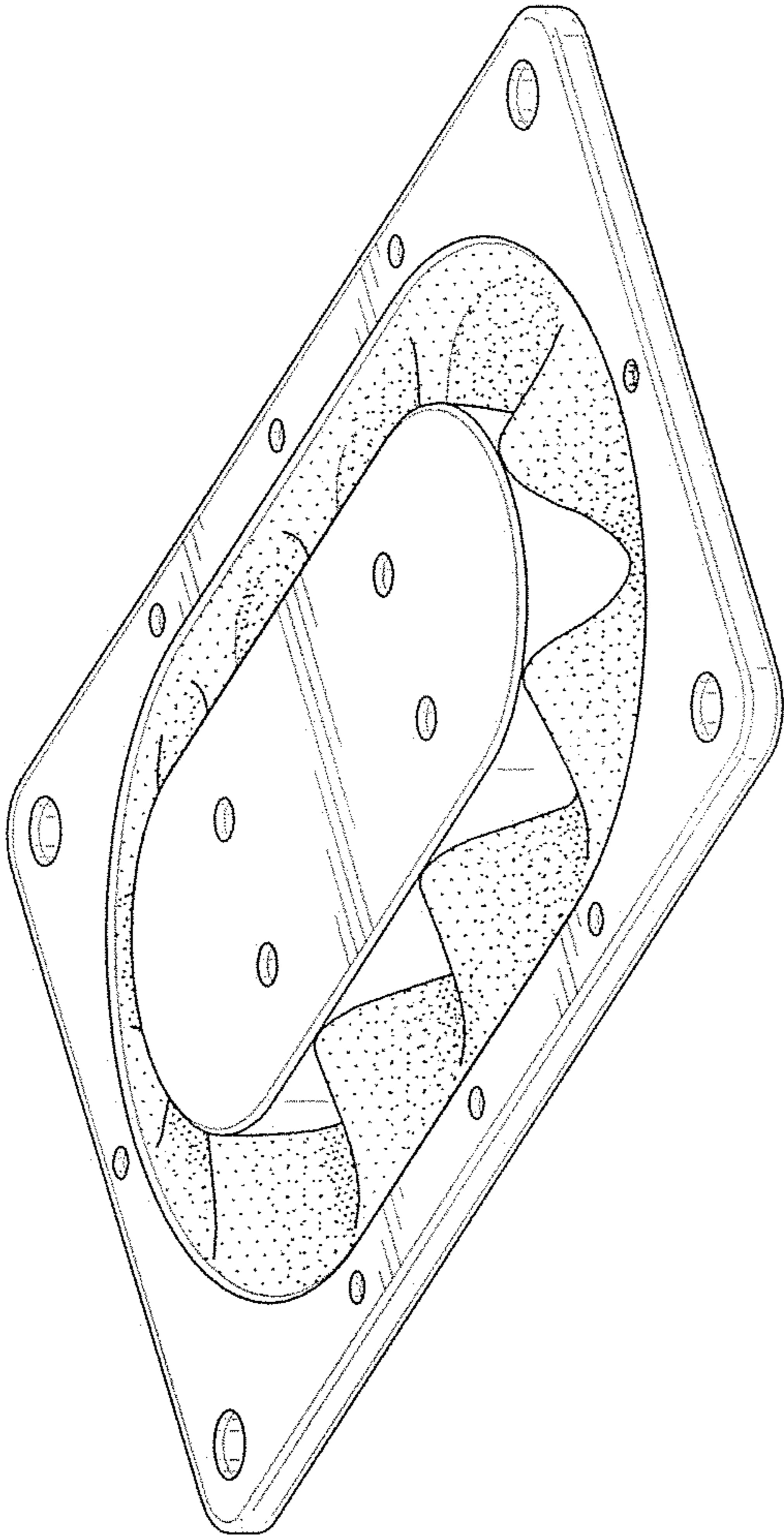

FIG.1

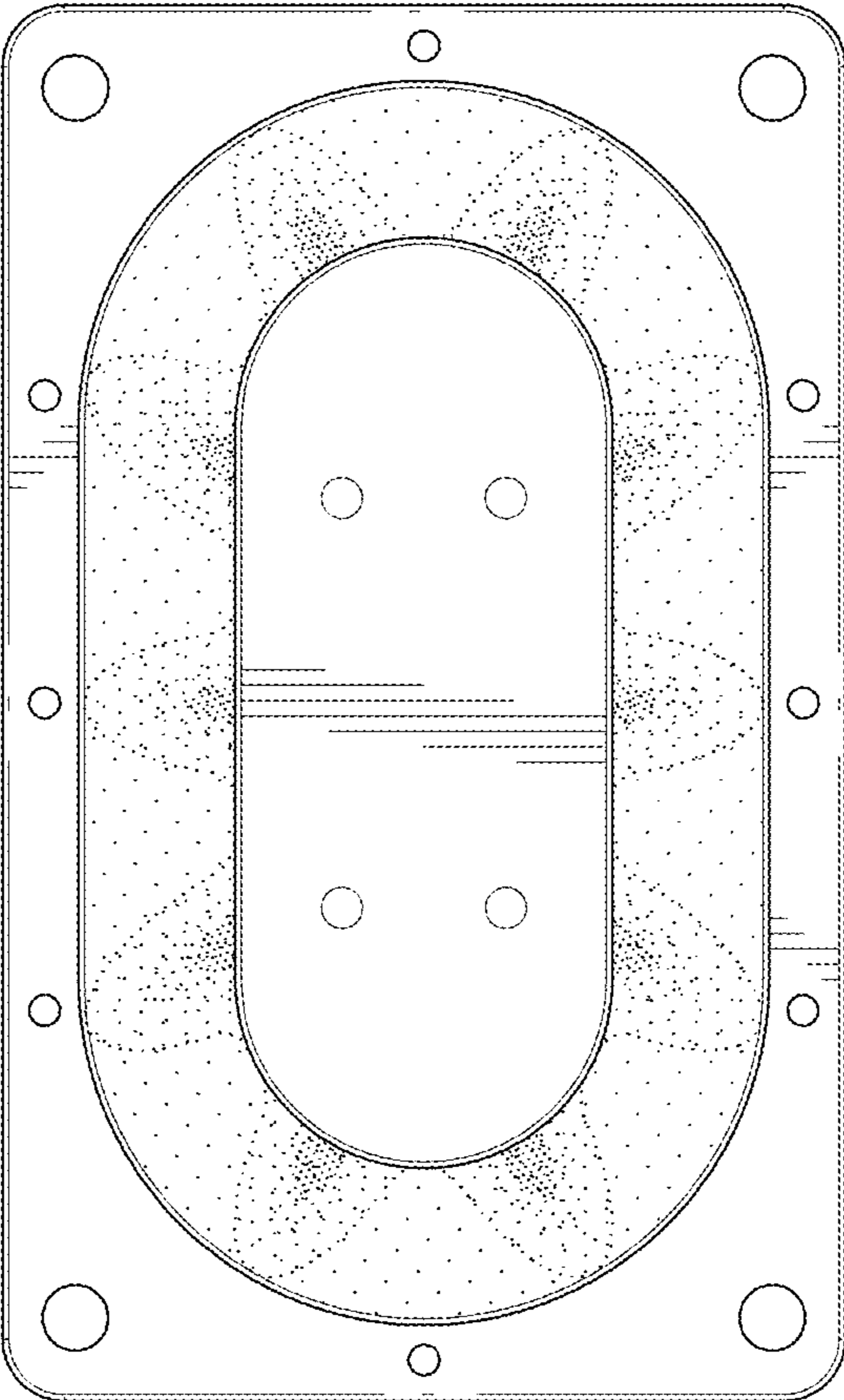

FIG.2

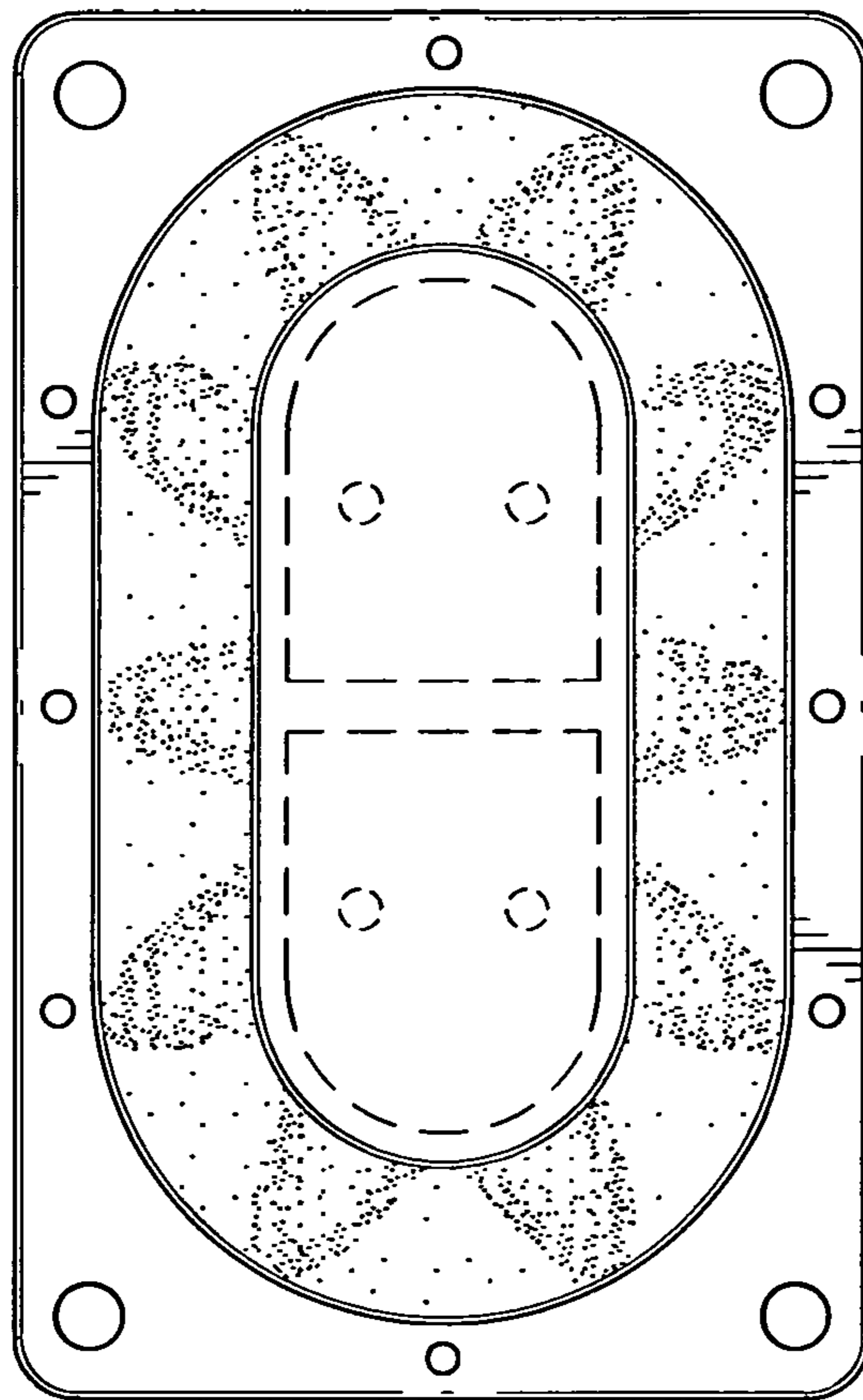

FIG.3

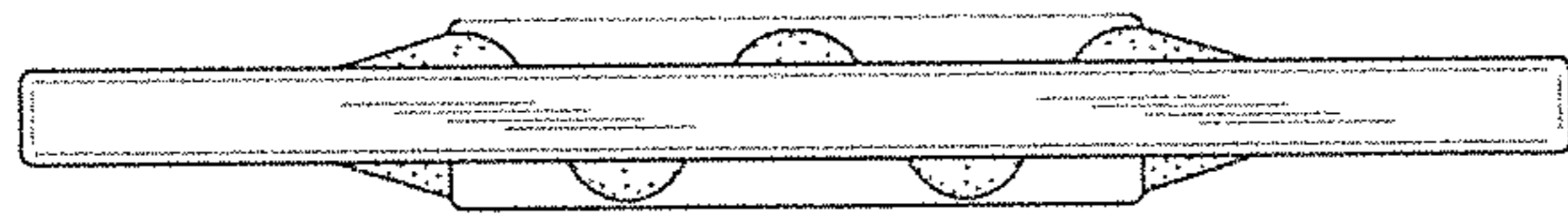

FIG. 5

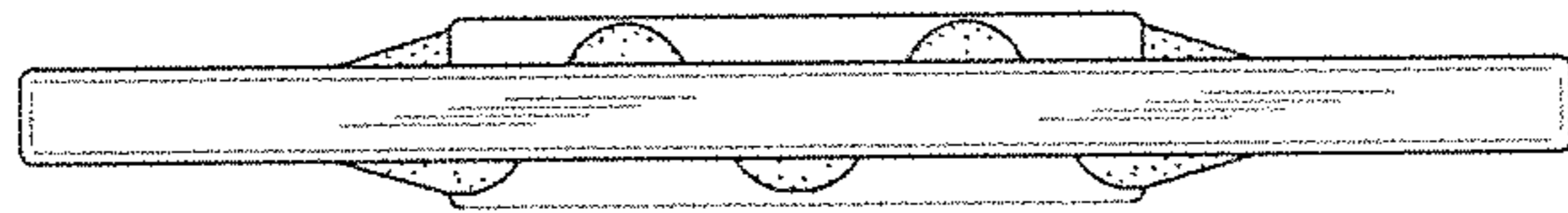

FIG. 4



FIG. 6



FIG. 7