



US00D744163S

(12) **United States Design Patent**  
**Lee**

(10) **Patent No.:** **US D744,163 S**  
(45) **Date of Patent:** **\*\* Nov. 24, 2015**

(54) **HEATER FOR PERMANENT WAVES**

**DESCRIPTION**

(71) Applicant: **Seung-Soo Lee**, Seoul (KR)

(72) Inventor: **Seung-Soo Lee**, Seoul (KR)

(\*\*) Term: **14 Years**

(21) Appl. No.: **29/456,182**

(22) Filed: **May 29, 2013**

(30) **Foreign Application Priority Data**

Nov. 29, 2012 (KR) ..... 30-2012-0057285

(51) **LOC (10) Cl.** ..... **28-03**

(52) **U.S. Cl.**  
USPC ..... **D28/17**

(58) **Field of Classification Search**  
USPC ..... D28/12-19; 34/96-101; 392/380-385;  
219/222

CPC ..... A45D 20/12; A45D 20/00  
See application file for complete search history.

(56) **References Cited**

**U.S. PATENT DOCUMENTS**

D247,379 S *	2/1978	Hashino	.....	D28/17
D314,065 S *	1/1991	Kakuya	.....	D28/17
D321,411 S *	11/1991	Moll	.....	D28/17
D477,111 S *	7/2003	Zimmermann	.....	D28/17
D497,687 S *	10/2004	Takada	.....	D28/17
D501,061 S *	1/2005	Patzak	.....	D28/17
D527,490 S *	8/2006	Patzak	.....	D28/17
D674,540 S *	1/2013	Kabetani et al.	.....	D28/17

\* cited by examiner

*Primary Examiner* — Zenia Bennett

(74) *Attorney, Agent, or Firm* — Westman, Champlin & Koehler, P.A.; Z. Peter Sawicki

(57) **CLAIM**

The ornamental design for a heater for permanent waves, as shown and described.

FIG. 1 is a perspective view of a heater for permanent waves. FIG. 2 is a front view thereof. FIG. 3 is a rear view thereof. FIG. 4 is a left side view thereof. FIG. 5 is a plan view thereof. FIG. 6 is a bottom view thereof. FIG. 7 is a rear perspective view thereof. FIG. 8 is an enlarged front view of the heater arrangement illustrated in FIG. 7 illustrating a first radial area of the component illustrated within dashed circle 14 of FIG. 7. FIG. 9 is an enlarged front view of the heater arrangement illustrated in FIG. 7 illustrating a second radial area of the component illustrated within dashed circle 14 of FIG. 7. FIG. 10 is an enlarged front view of the heater arrangement illustrated in FIG. 7 illustrating a third radial area of the component illustrated within dashed circle 14 of FIG. 7. FIG. 11 is an enlarged front view of the heater arrangement illustrated in FIG. 7 illustrating a fourth radial area of the component illustrated within dashed circle 14 of FIG. 7. FIG. 12 is an enlarged front view of the heater arrangement illustrated in FIG. 7 illustrating a fifth radial area of the component illustrated within dashed circle 14 of FIG. 7. FIG. 13 is an enlarged front view of the heater arrangement illustrated in FIG. 7 illustrating a sixth radial area of the component illustrated within dashed circle 14 of FIG. 7; and, FIG. 14 is an enlarged perspective view of the component within dashed circle 14 of FIG. 7.

The right side of the heater for permanent waves is symmetrical with the left side.

1. It is made of metal and synthetic resin.
2. The heater for permanent waves according to the present design is used to perform a hair heating treatment process (including permanent waving, dyeing, hair clinic, drying, etc.). The heater for permanent waves according to the present design is configured such that a driving head part and an electrical and electronic part casing are connected to each other by means of a linkage frame having a circular or square cross-section so that first and second heating swing parts symmetrically or asymmetrically assembled to a shaft of a speed reduction motor built in the driving head part can maintain a stable center of gravity when rotated at a constant speed by 360° as shown in a rear perspective view of a reference FIG. 1.
3. The heater for permanent waves according to the present design is also configured such that each of first and second heating swing parts is formed in an elliptical shape, is rotated at a constant speed by the drive of a speed reduction motor by

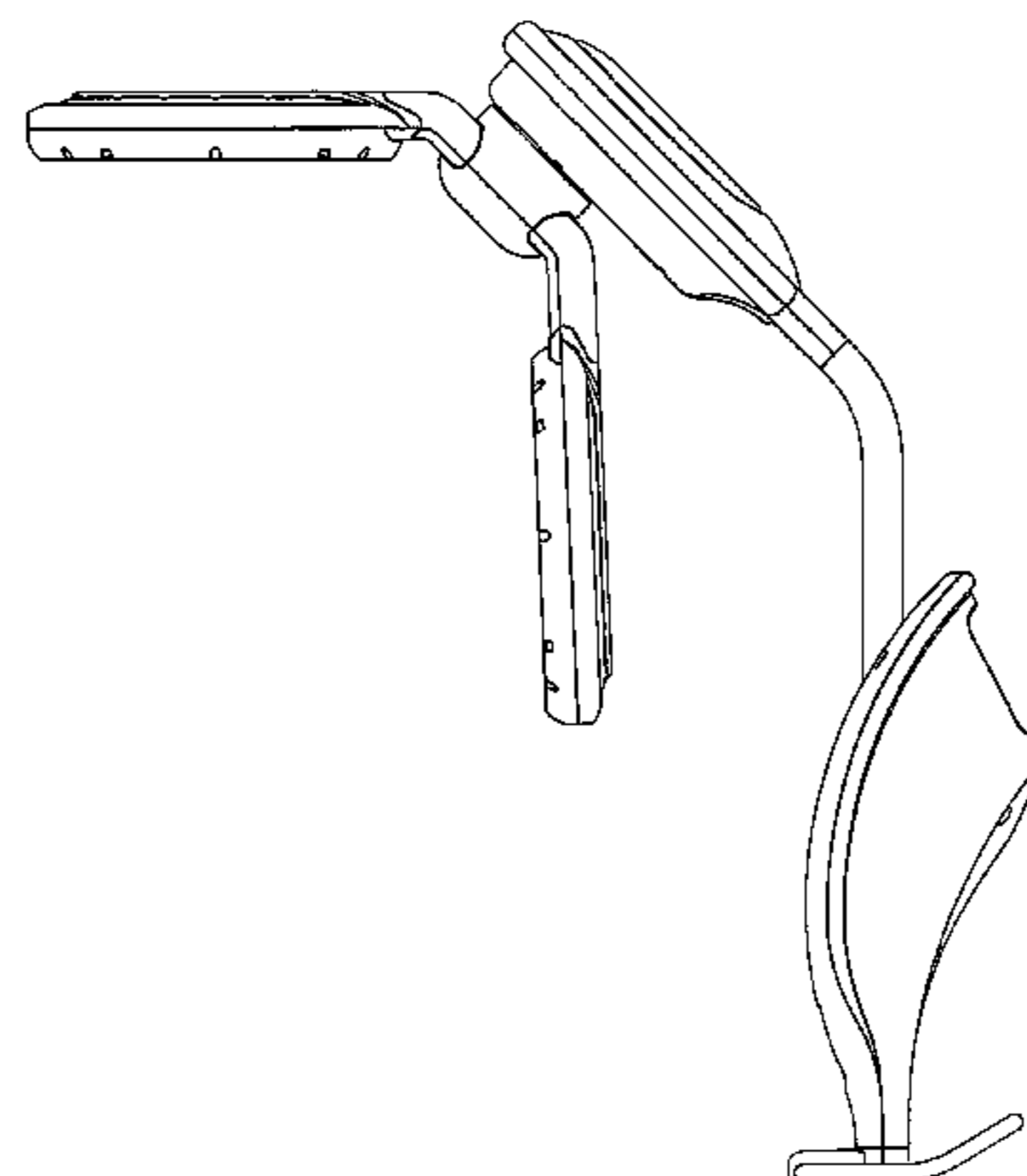
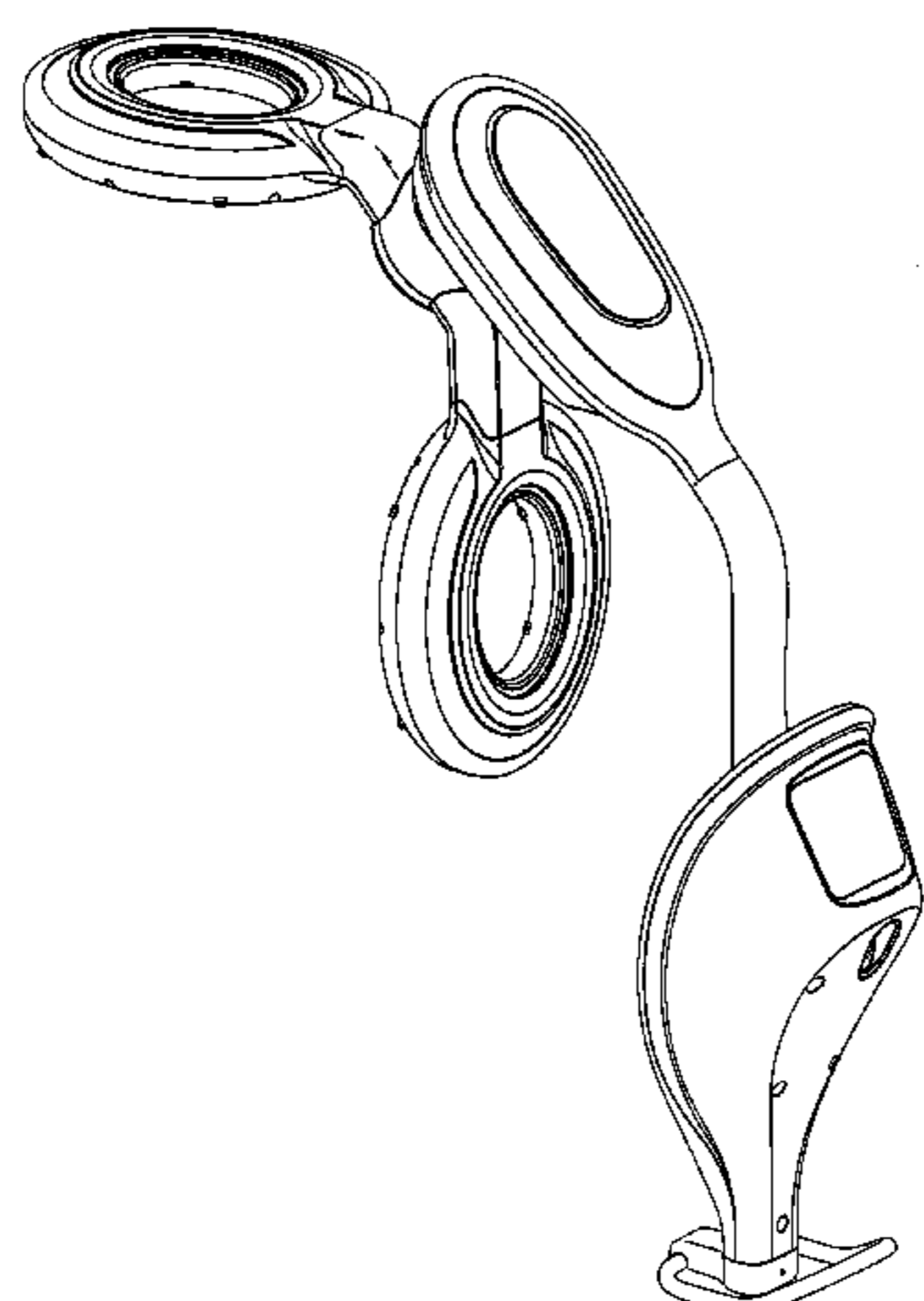

360°, and includes an infrared ray radiation heater (e.g., nano carbon heater) and a reflective plate with an elliptical shape mounted on the inside thereof and a protective grille mounted on a front edge thereof so that the first and second heating swing parts perform a uniform heat radiation while rotated around a subject's head.

4. The heater for permanent waves according to the present design is also configured such that an electrical and electronic part casing includes a touch switch type control unit mounted on a front upper end thereof so as to set a treatment mode, etc., so that the temperature or time depending on a permanent waving or hair dyeing treatment can be set arbitrarily, and a moveable height adjustment stand mounted to a lower end thereof so that the heater for permanent waves can be moved to a desired place in use as shown in a perspective view showing the coupling of a stand and a side view showing the use state of reference views 2 and 3.

5. The heater for permanent waves according to the present design is also configured such that the center point of rotation of a second heating wing part is formed longer than that of a first heating wing part, and is assembled to the shaft of a speed reduction motor built in the driving head part to further form an inclination angle ( $\angle\alpha$ ) to the outside than the first heating wing part so that the first and second heating wing parts are rotated to different heat radiation orbit sections to cause heat to be uniformly radiated onto the subject's head correspondingly to the length of his or her hair as shown in a side view showing the use state of a reference FIG. 3.

The main point of the creative design contents is a combination of appearance and shape of a "heater for permanent waves".

**1 Claim, 14 Drawing Sheets**

FIG. 1

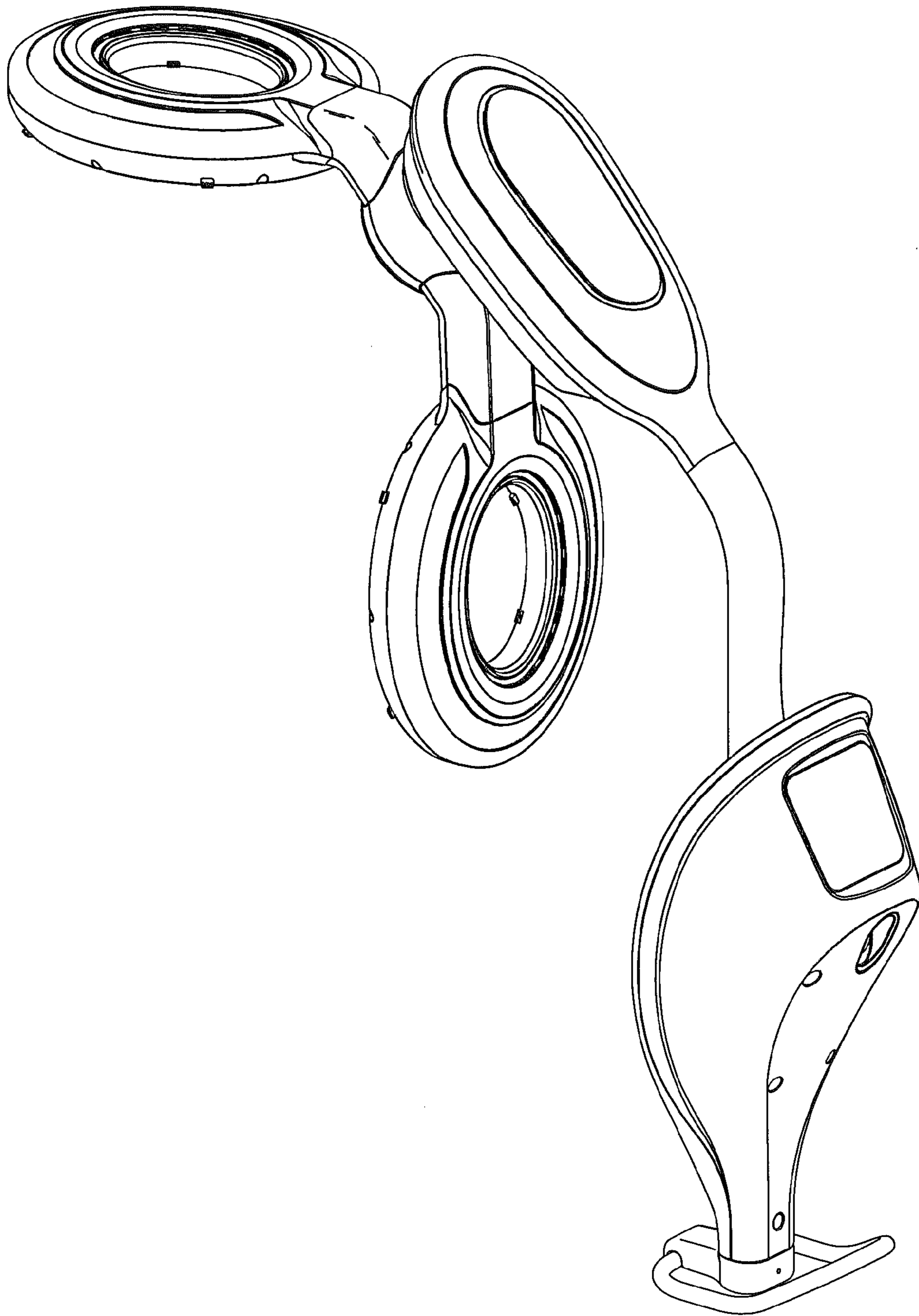

FIG. 2

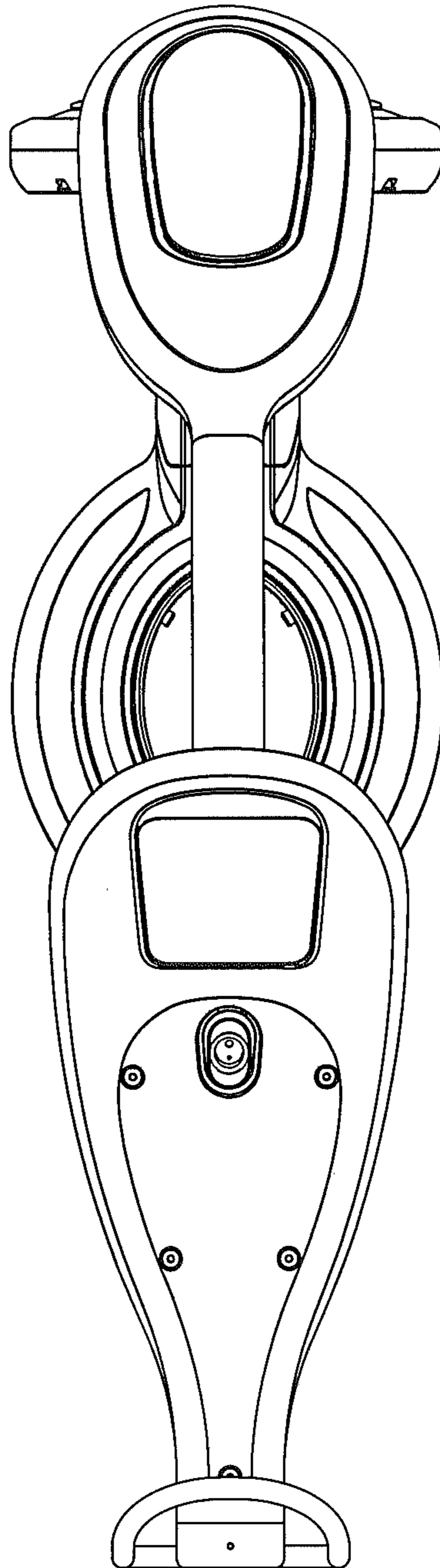

FIG. 3

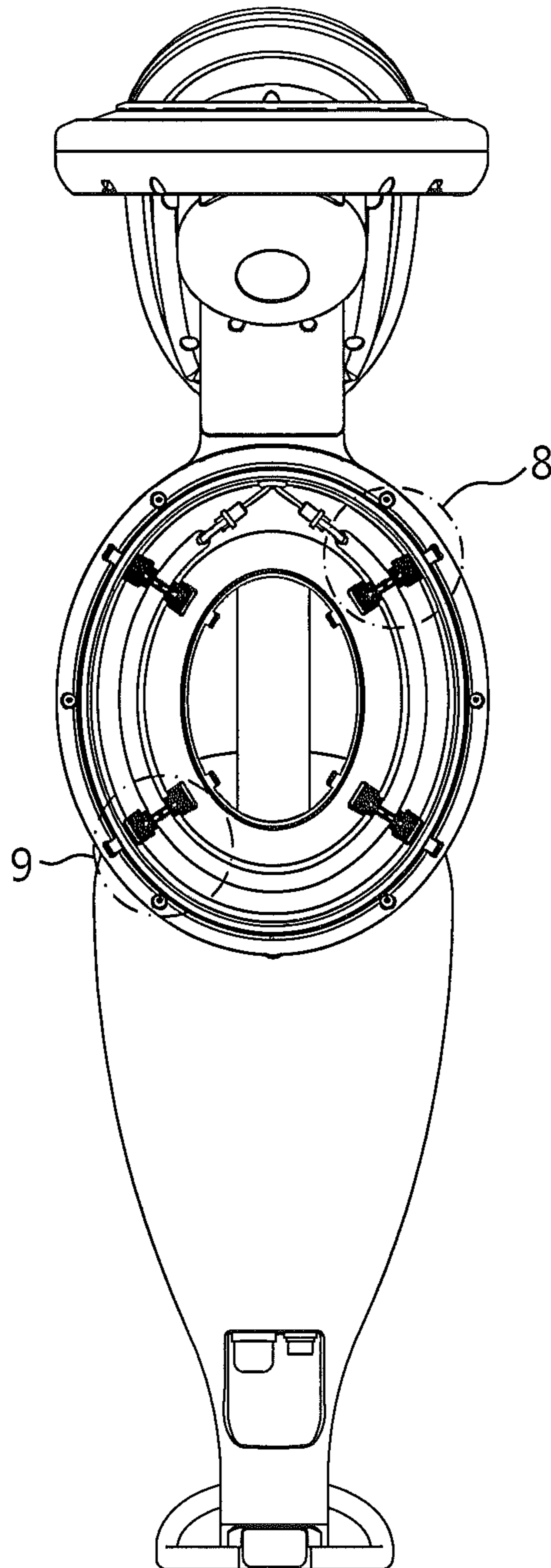

FIG. 4

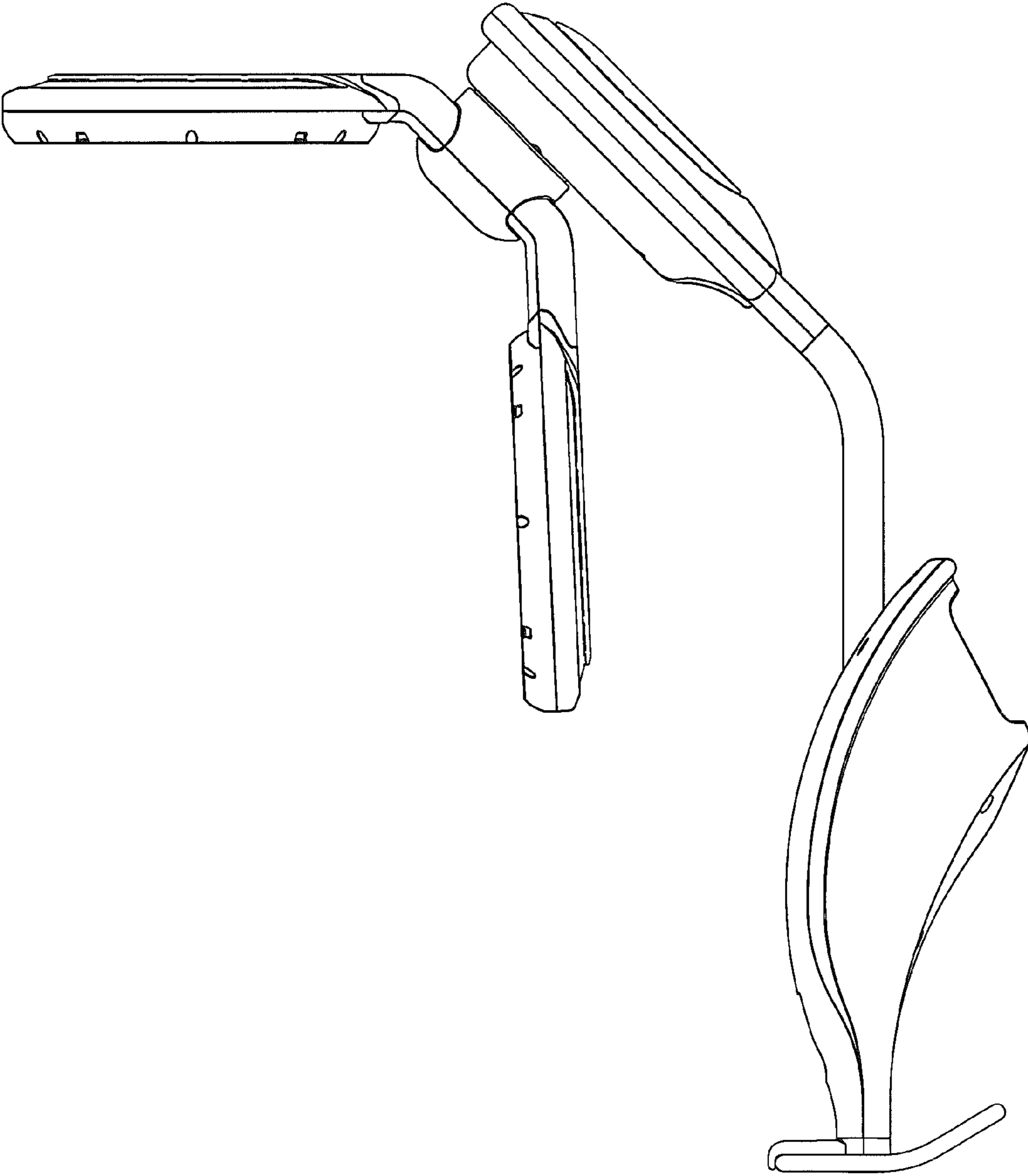

FIG. 5

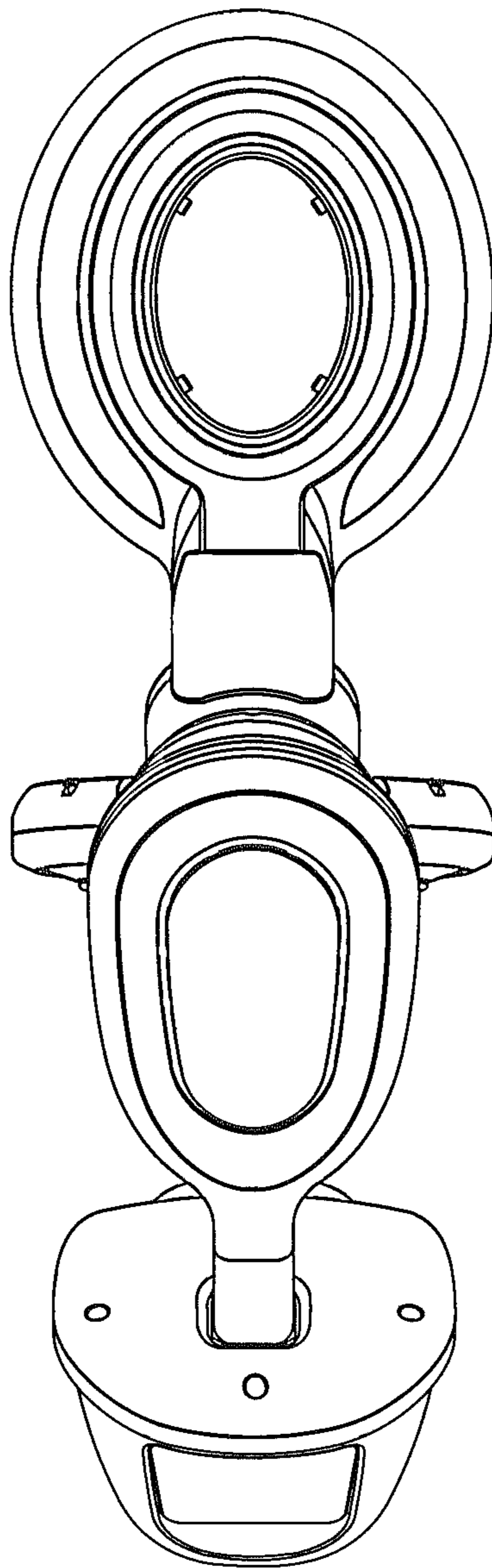

FIG. 6

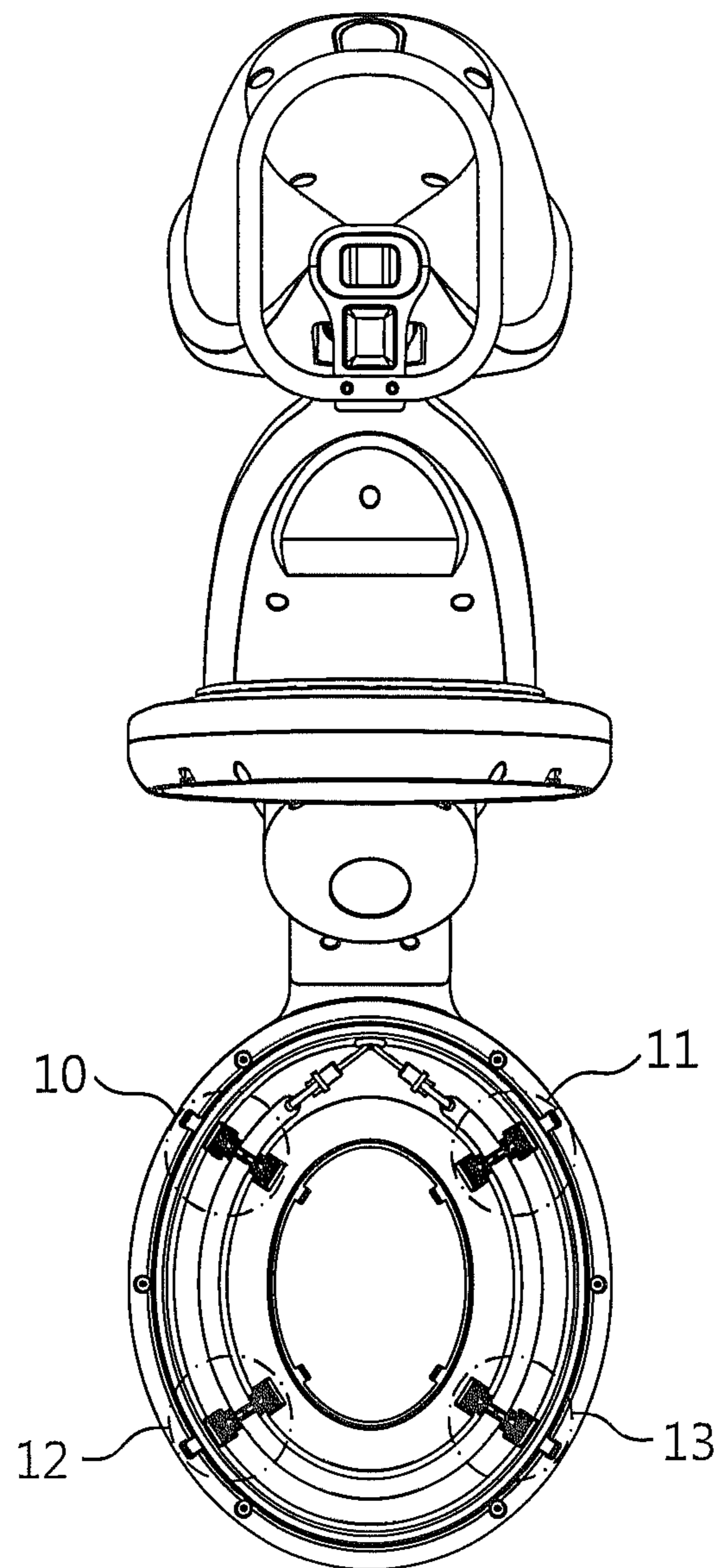



FIG. 7

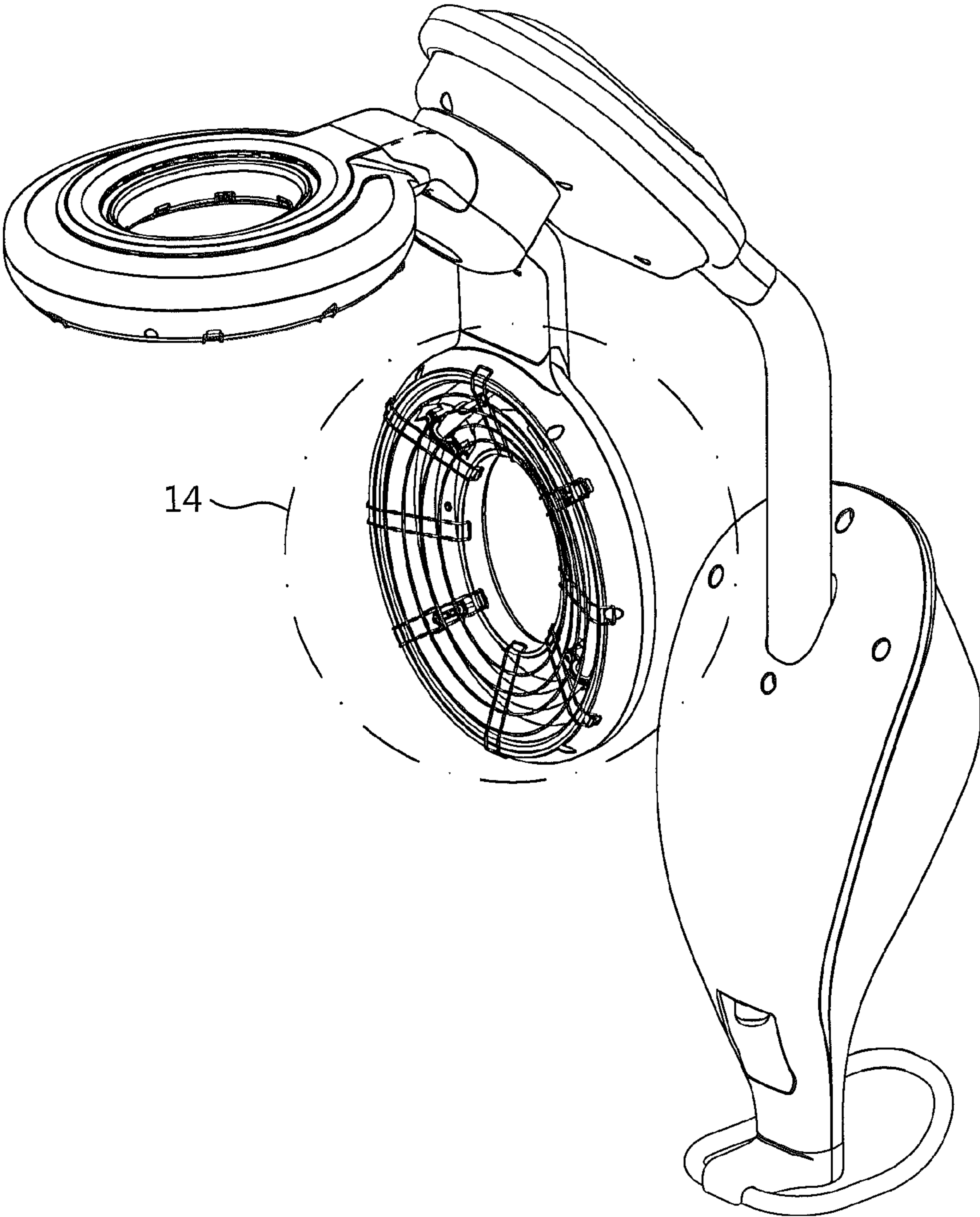

FIG. 8

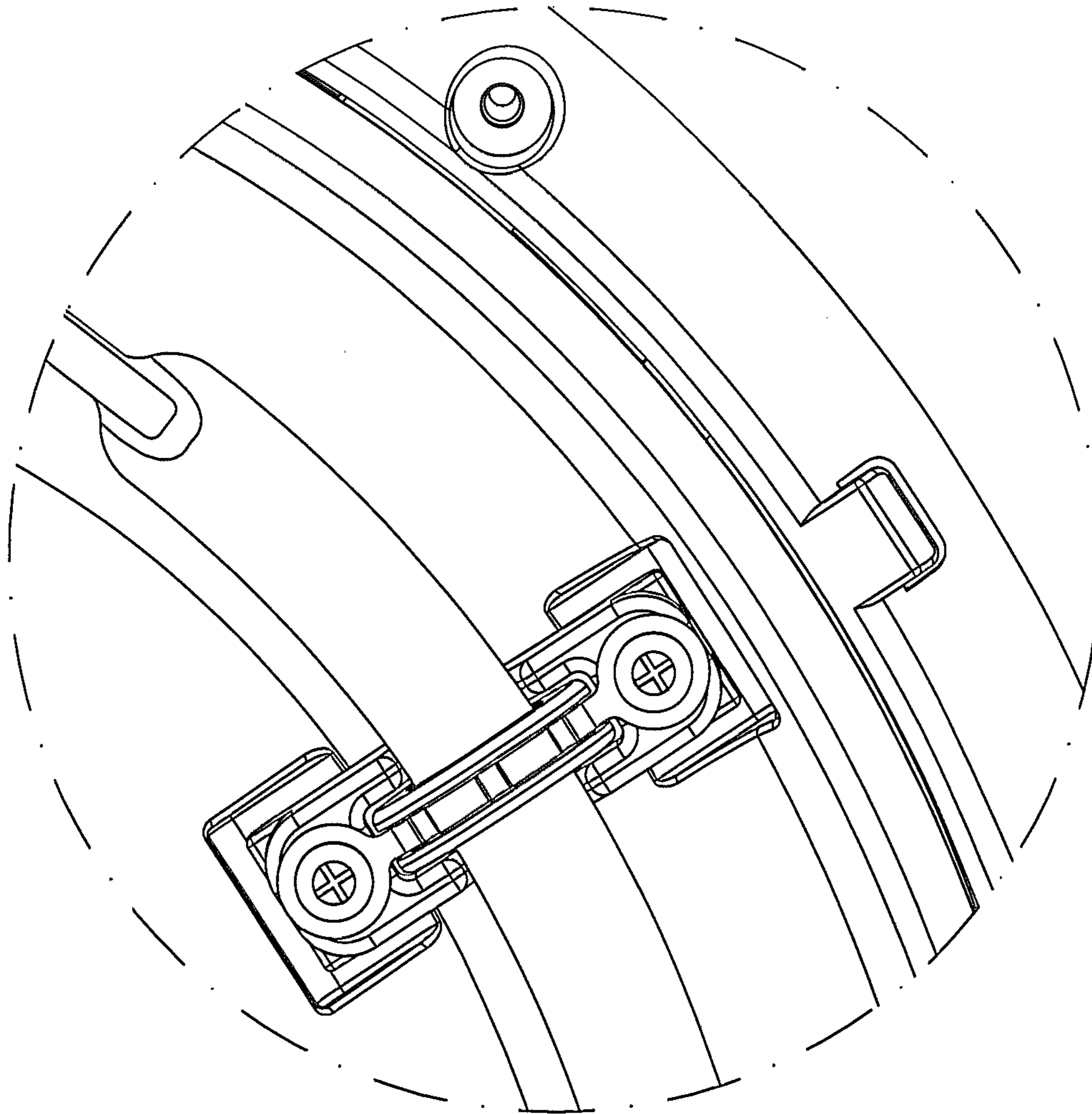

FIG. 9

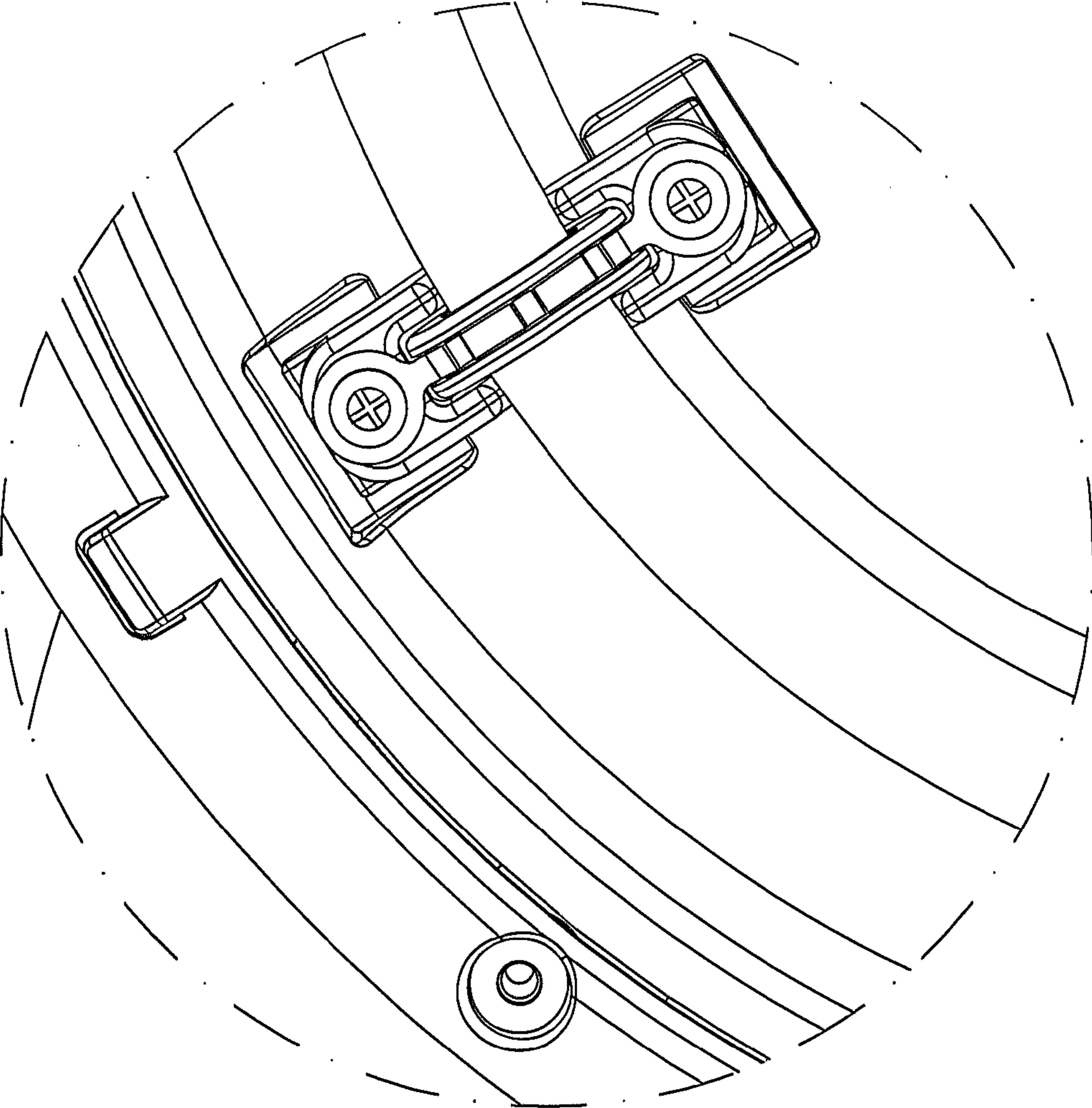

FIG. 10

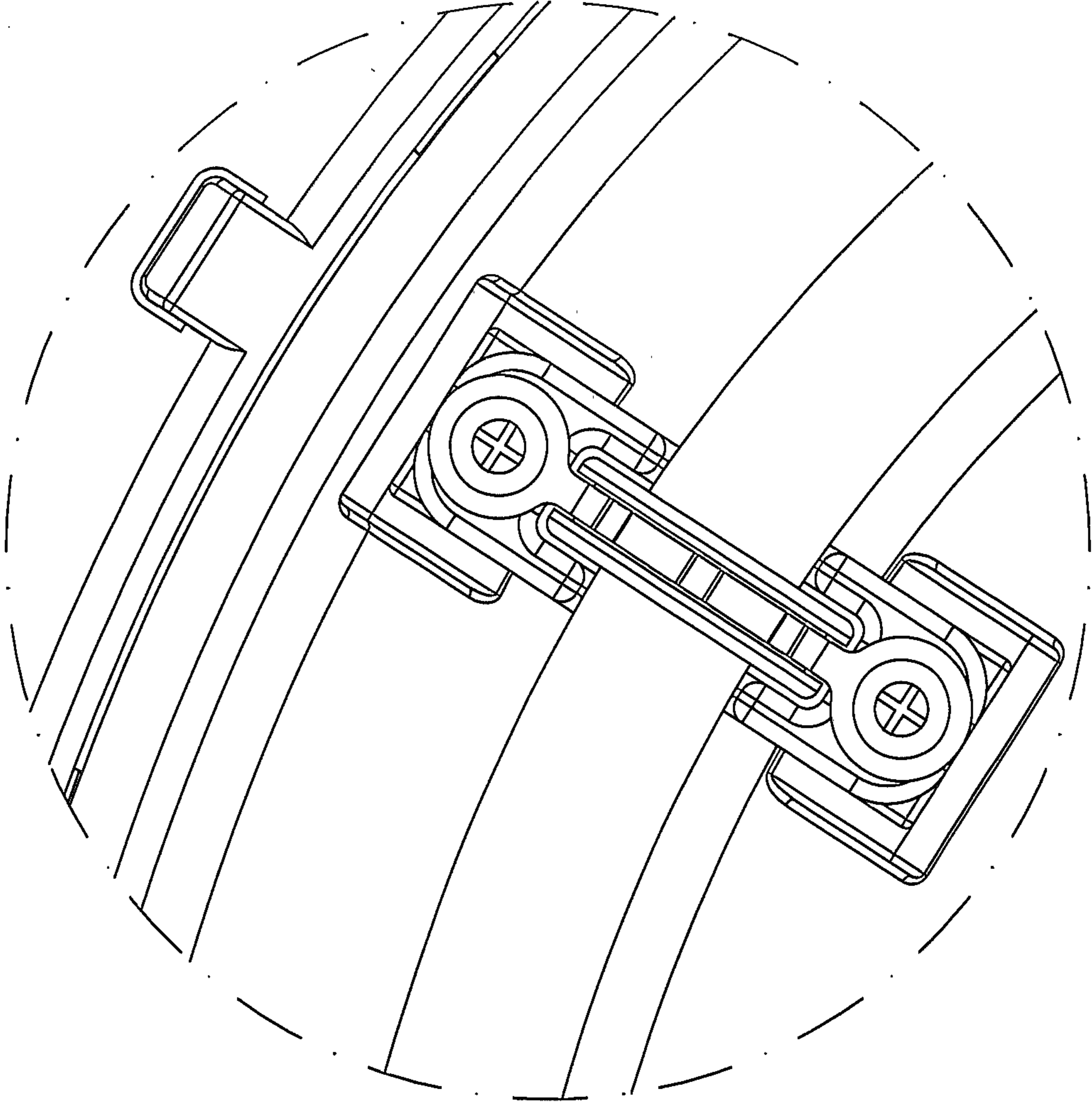

FIG. 11

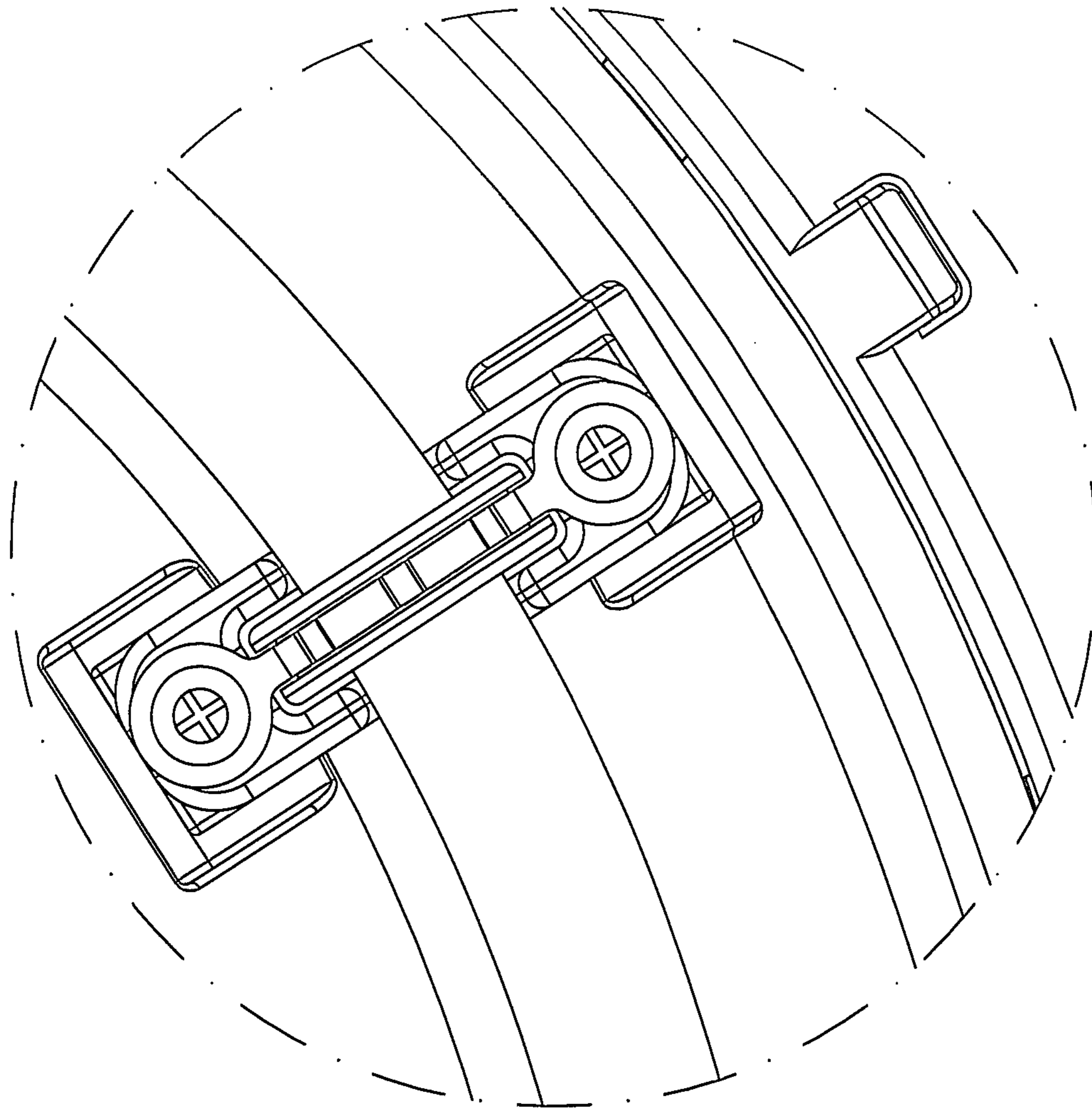

FIG. 12

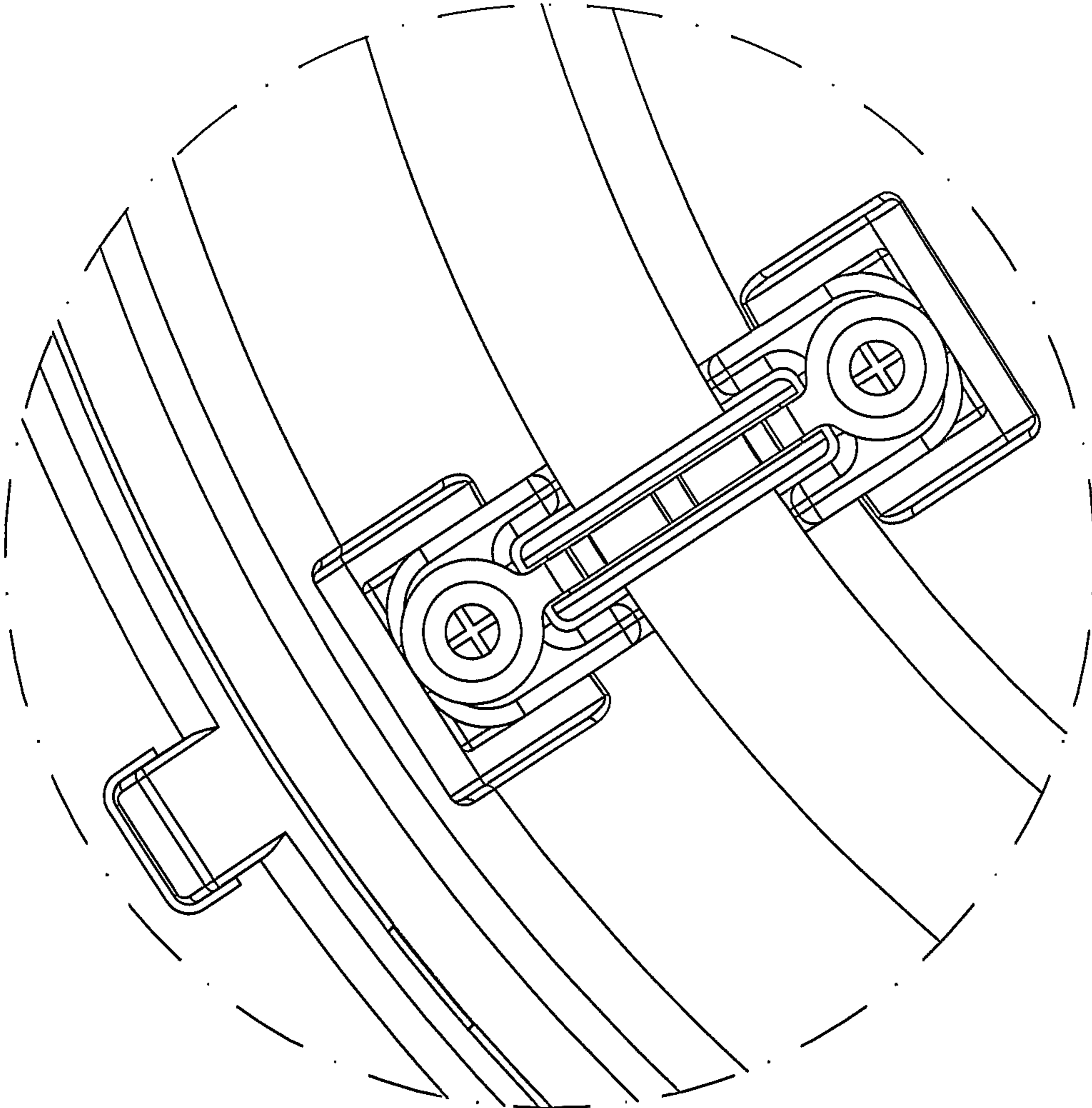

FIG. 13

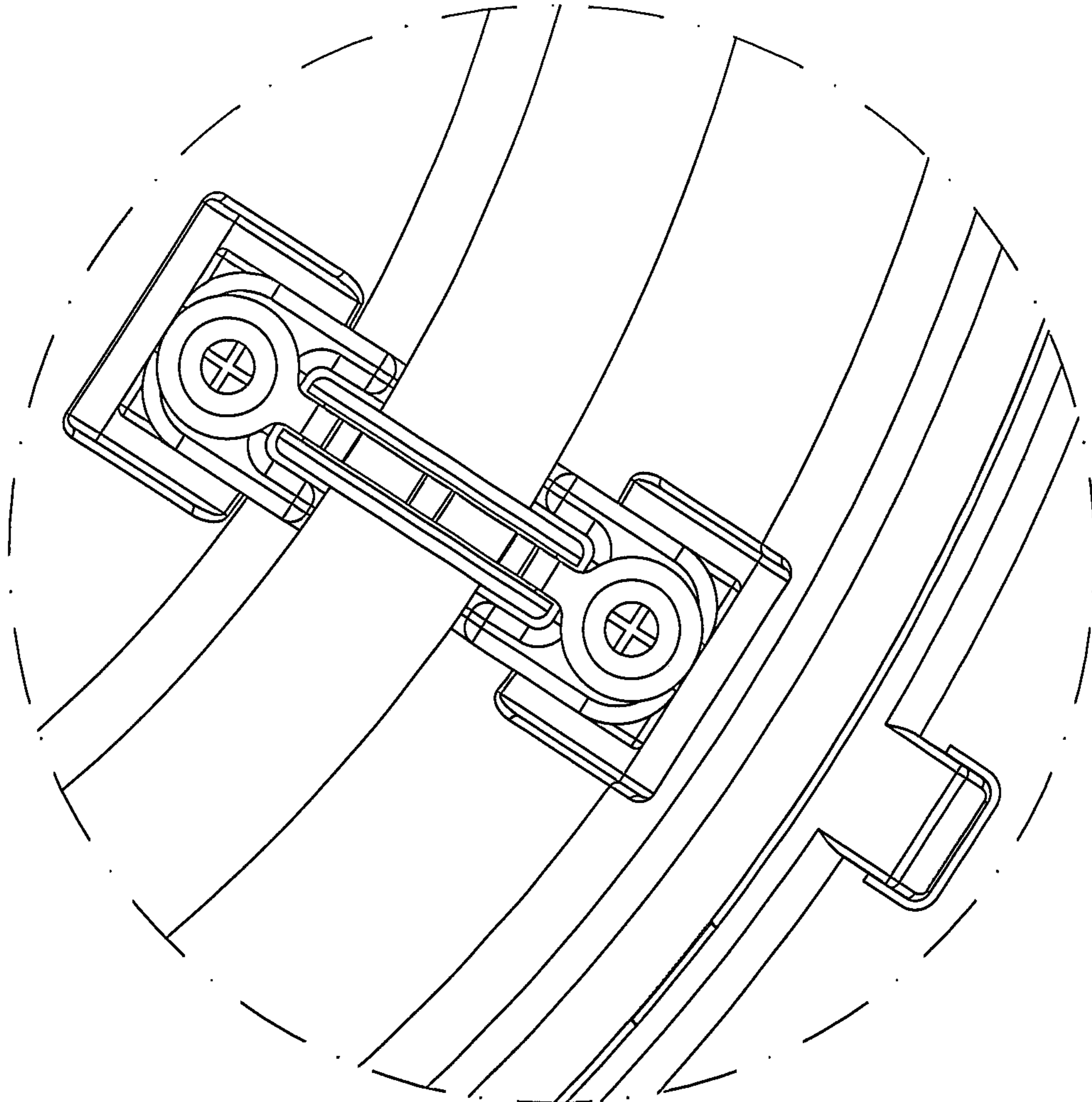

FIG. 14

