



US00D744058S

(12) **United States Design Patent**
Dee

(10) **Patent No.:** **US D744,058 S**

(45) **Date of Patent:** **** Nov. 24, 2015**

(54) **TARGET**

(71) Applicant: **RA Brands, L.L.C.**, Madison, NC (US)

(72) Inventor: **Amy Dee**, Oak Ridge, NC (US)

(73) Assignee: **RA Brands, L.L.C.**, Madison, NC (US)

(**) Term: **14 Years**

(21) Appl. No.: **29/489,286**

(22) Filed: **Apr. 29, 2014**

(51) **LOC (10) Cl.** **22-03**

(52) **U.S. Cl.**
USPC **D22/113**

(58) **Field of Classification Search**
USPC D22/113, 117; 463/52–56; 273/331,
273/348, 407, 127 R, 190
CPC F41J 1/00; F41J 1/01; F41J 1/08;
F41J 1/10; F41J 5/18; F41J 5/20; F41J 5/205;
F41J 5/22; F41J 9/00; F41J 9/02; F41J 9/04;
F41J 9/06; F41J 9/08; F41J 9/10; F41J 9/14;
F41J 9/16

See application file for complete search history.

(56) **References Cited**

U.S. PATENT DOCUMENTS

1,103,579	A	7/1914	Hall	
2,587,042	A	2/1952	Haiselup	
2,613,080	A *	10/1952	Dow	273/383
2,812,947	A	11/1957	Fatzinger et al.	
D195,308	S	5/1963	Braun	
D201,027	S	5/1965	Maher	
3,423,092	A *	1/1969	Kandel	273/378
4,203,600	A	5/1980	Brown	
4,249,743	A	2/1981	Lee	
4,433,843	A	2/1984	Bricco	
D287,614	S	1/1987	Mosser	
4,732,394	A	3/1988	Stein et al.	
D330,920	S	11/1992	Schaefer et al.	
5,273,291	A	12/1993	Giannetti	
5,383,671	A *	1/1995	Teets et al.	273/407
5,590,885	A	1/1997	Graham et al.	
5,593,162	A	1/1997	Minuskin	
D382,599	S	8/1997	Starrett	

D391,303	S	2/1998	Hadland	
7,815,192	B1	10/2010	Kreiman et al.	
8,091,894	B2 *	1/2012	Kreiman et al.	273/390
D655,756	S	3/2012	Robertson	
8,413,991	B2	4/2013	Sudbeck et al.	
9,068,800	B2 *	6/2015	McHale et al.	
2007/0046760	A1 *	3/2007	Zara	347/105
2007/0063445	A1	3/2007	Tierney et al.	
2007/0262529	A1 *	11/2007	Gamez et al.	273/409
2008/0054570	A1 *	3/2008	Potterfield et al.	273/403
2008/0277876	A1	11/2008	Riley	
2009/0058008	A1	3/2009	Baumgartner et al.	
2014/0319215	A1 *	10/2014	Farca et al.	235/404
2014/0360081	A1 *	12/2014	Lupher et al.	42/120

OTHER PUBLICATIONS

“Knockdown Rabbit Target” www.whipperleys.co.uk, www.whipperleys.co.uk/acatalog/shooting_targets.html (Accessed Apr. 30, 2014).

“Knockdown Resetting Rabbit Target” www.solware.co.uk, <http://www.solware.co.uk/air-pistol-air-rifle/Air-Arms-Knockdown-Rabbit.shtml> (Accessed Apr. 30, 2014).

“Gamo Knockdown Wild Boar Field Target Interchangeable System” www.taskers-angling.co.uk, <http://www.taskers-angling.co.uk/gamo-knockdown-wild-boar-field-target-interchangeable-sy>.

“SMK Training Knock and Reset Crow Target” www.whipperleys.co.uk, http://www.whipperleys.co.uk/acatalog/shooting_targets.html (Accessed Apr. 30, 2014).

“SMK Training Knock and Reset Pigeon Target” www.whipperleys.co.uk, http://www.whipperleys.co.uk/acatalog/shooting_targets.html.

Notice of Allowance issued Aug. 26, 2015 in Design U.S. Appl. No. 29/489,287.

* cited by examiner

Primary Examiner — Michael A Pratt

(74) *Attorney, Agent, or Firm* — Womble Carlyle Sandridge & Rice, LLP

(57) **CLAIM**

The ornamental design for a target, as shown in the accompanying drawings and described above.

DESCRIPTION

FIG. 1 is a front perspective view of a target in a first configuration, in accordance with a first embodiment of the present invention;

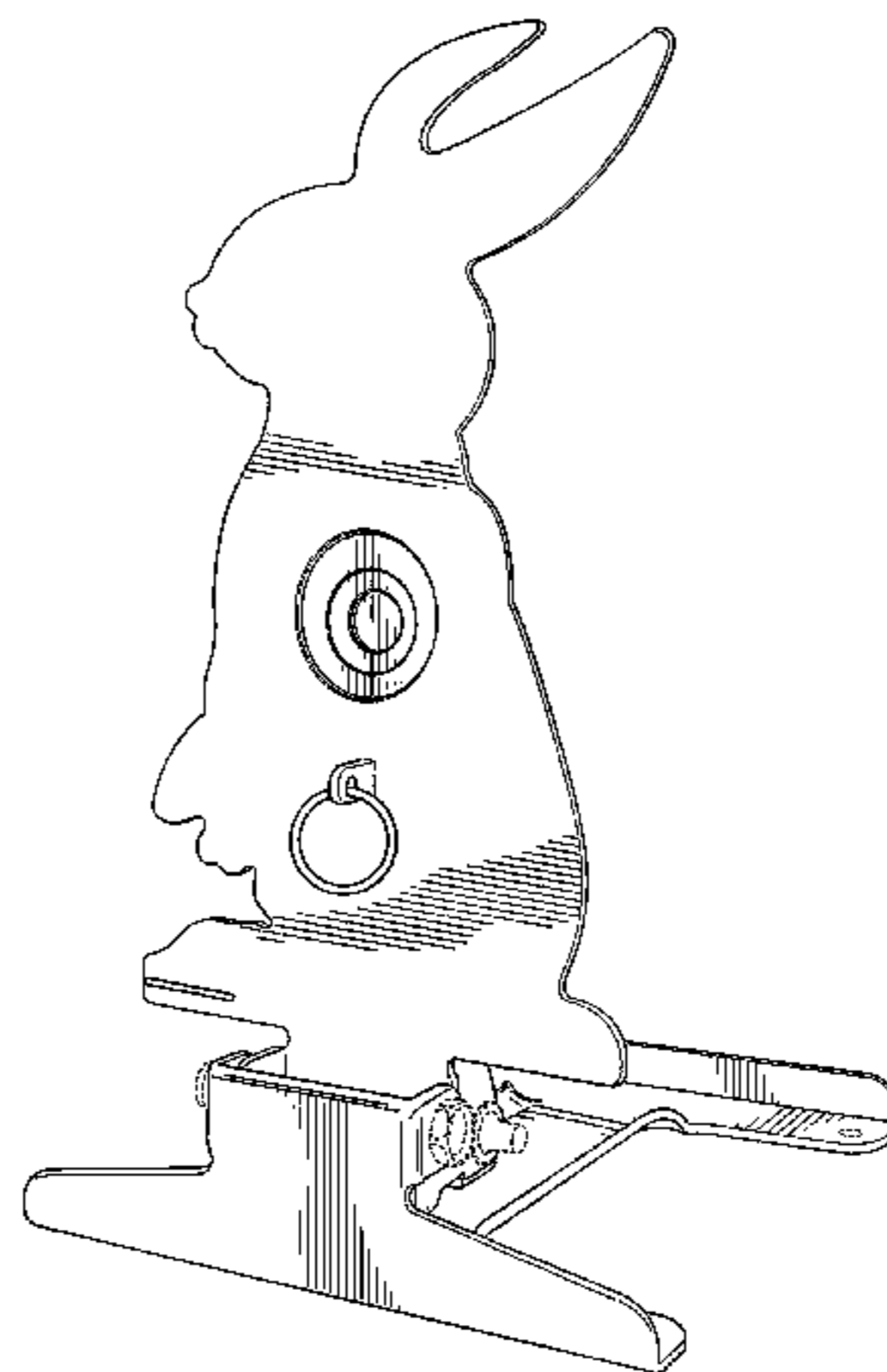

FIG. 2 is a rear perspective view of the target of FIG. 1 in the first configuration;
FIG. 3 is a front elevation view of the target of FIG. 1 in the first configuration;
FIG. 4 is a rear elevation view of the target of FIG. 1 in the first configuration;
FIG. 5 is a right elevation view of the target of FIG. 1 in the first configuration;
FIG. 6 is a left elevation view of the target of FIG. 1 in the first configuration;
FIG. 7 is a top plan view of the target of FIG. 1 in the first configuration;
FIG. 8 is a bottom plan view of the target of FIG. 1 in the first configuration;
FIG. 9 is a front perspective view of the target of FIG. 1 in a second configuration, in accordance with the first embodiment of the present invention;
FIG. 10 is a front elevation view of the target of FIG. 1 in the second configuration;
FIG. 11 is a rear elevation view of the target of FIG. 1 in the second configuration;
FIG. 12 is a right elevation view of the target of FIG. 1 in the second configuration;
FIG. 13 is a left elevation view of the target of FIG. 1 in the second configuration;
FIG. 14 is a top plan view of the target of FIG. 1 in the second configuration;
FIG. 15 is a bottom plan view of the target of FIG. 1 in the second configuration;
FIG. 16 is a front perspective view of a target in a first configuration, in accordance with a second embodiment of the present invention;
FIG. 17 is a rear perspective view of the target FIG. 16 in the first configuration;
FIG. 18 is a front elevation view of the target of FIG. 16 in the first configuration;

FIG. 19 is a rear elevation view of the target of FIG. 16 in the first configuration;
FIG. 20 is a right elevation view of the target of FIG. 16 in the first configuration;
FIG. 21 is a left elevation view of the target of FIG. 16 in the first configuration;
FIG. 22 is a top plan view of the target of FIG. 16 in the first configuration;
FIG. 23 is a bottom plan view of the target of FIG. 16 in the first configuration;
FIG. 24 is a front perspective view of the target of FIG. 16 in a second configuration, in accordance with the second embodiment of the present invention;
FIG. 25 is a front elevation view of the target of FIG. 16 in the second configuration;
FIG. 26 is a rear elevation view of the target of FIG. 16 in the second configuration;
FIG. 27 is a right elevation view of the target of FIG. 16 in the second configuration;
FIG. 28 is a left elevation view of the target of FIG. 16 in the second configuration;
FIG. 29 is a top plan view of the target of FIG. 16 in the second configuration;
FIG. 30 is a bottom plan view of the target of FIG. 16 in the second configuration;
FIGS. 1-8 illustrate a target in accordance with a third embodiment of the present invention;
FIGS. 9-15 illustrate a target in accordance with a fourth embodiment of the present invention;
FIGS. 16-23 illustrate a target in accordance with a fifth embodiment of the present invention; and,
FIGS. 24-30 illustrate a target in accordance with a sixth embodiment of the present invention.
The broken lines shown herein are for illustrative purposes and form no part of the claimed design.

1 Claim, 30 Drawing Sheets

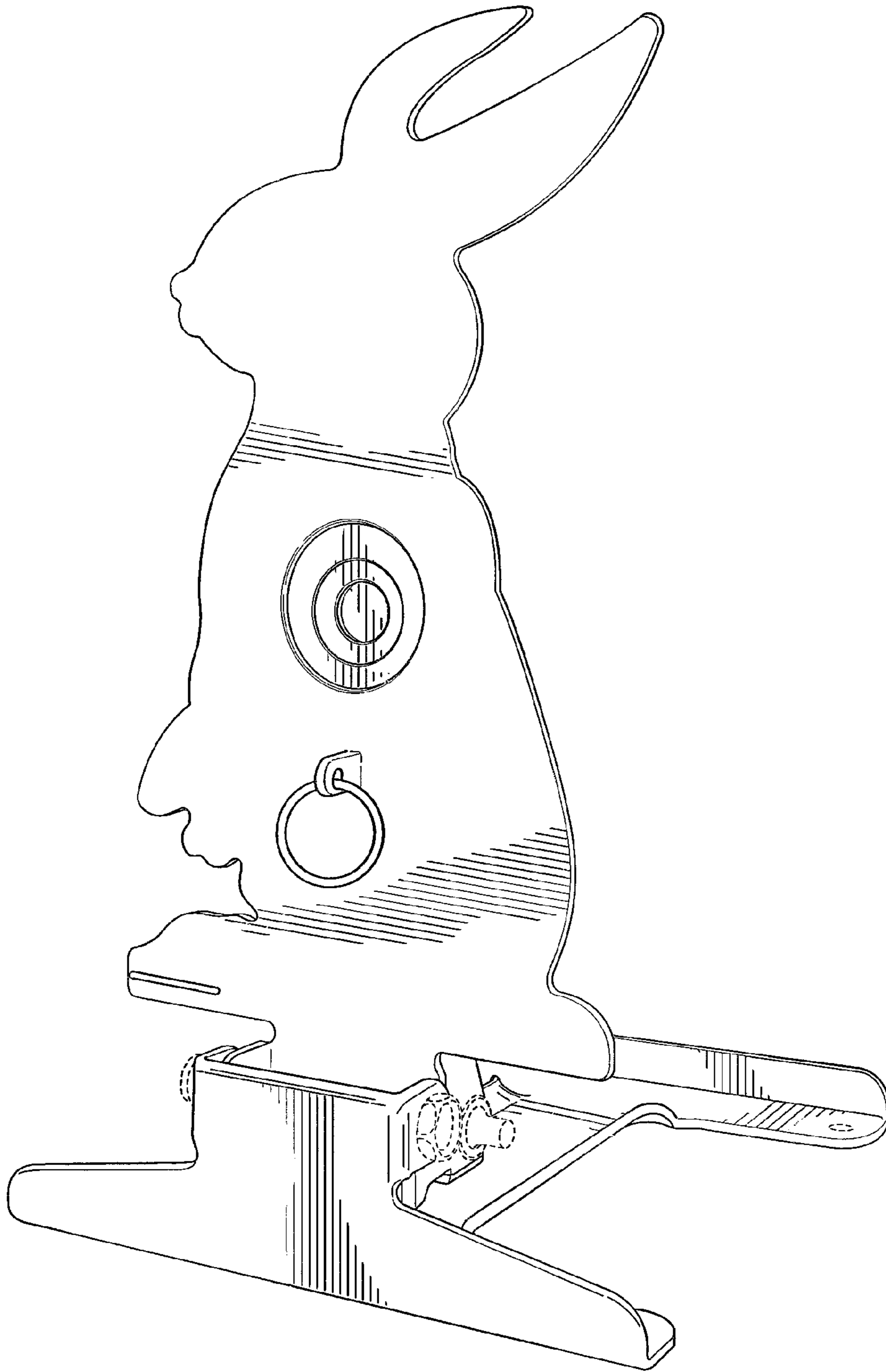

FIG. 1

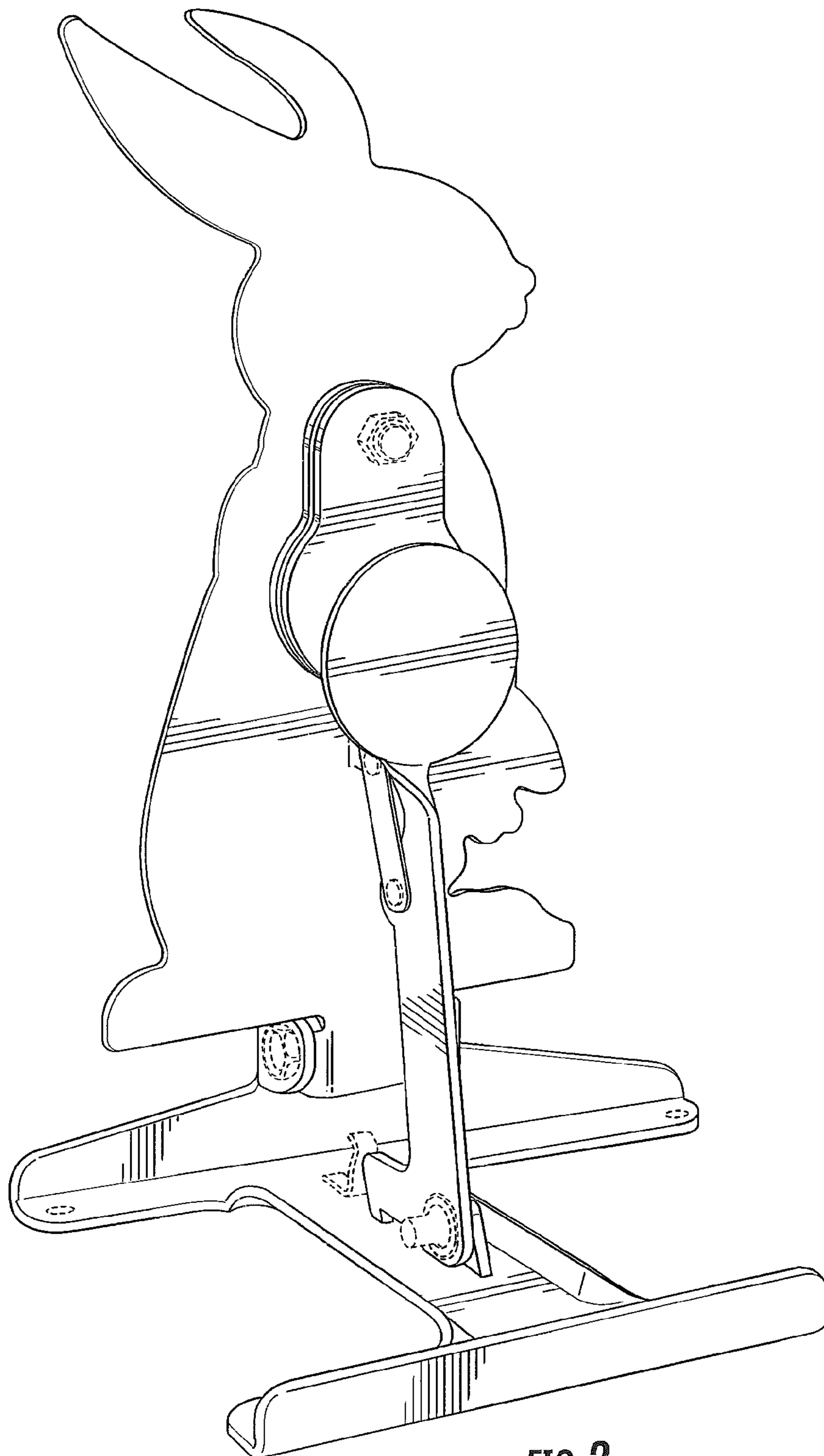

FIG. 2

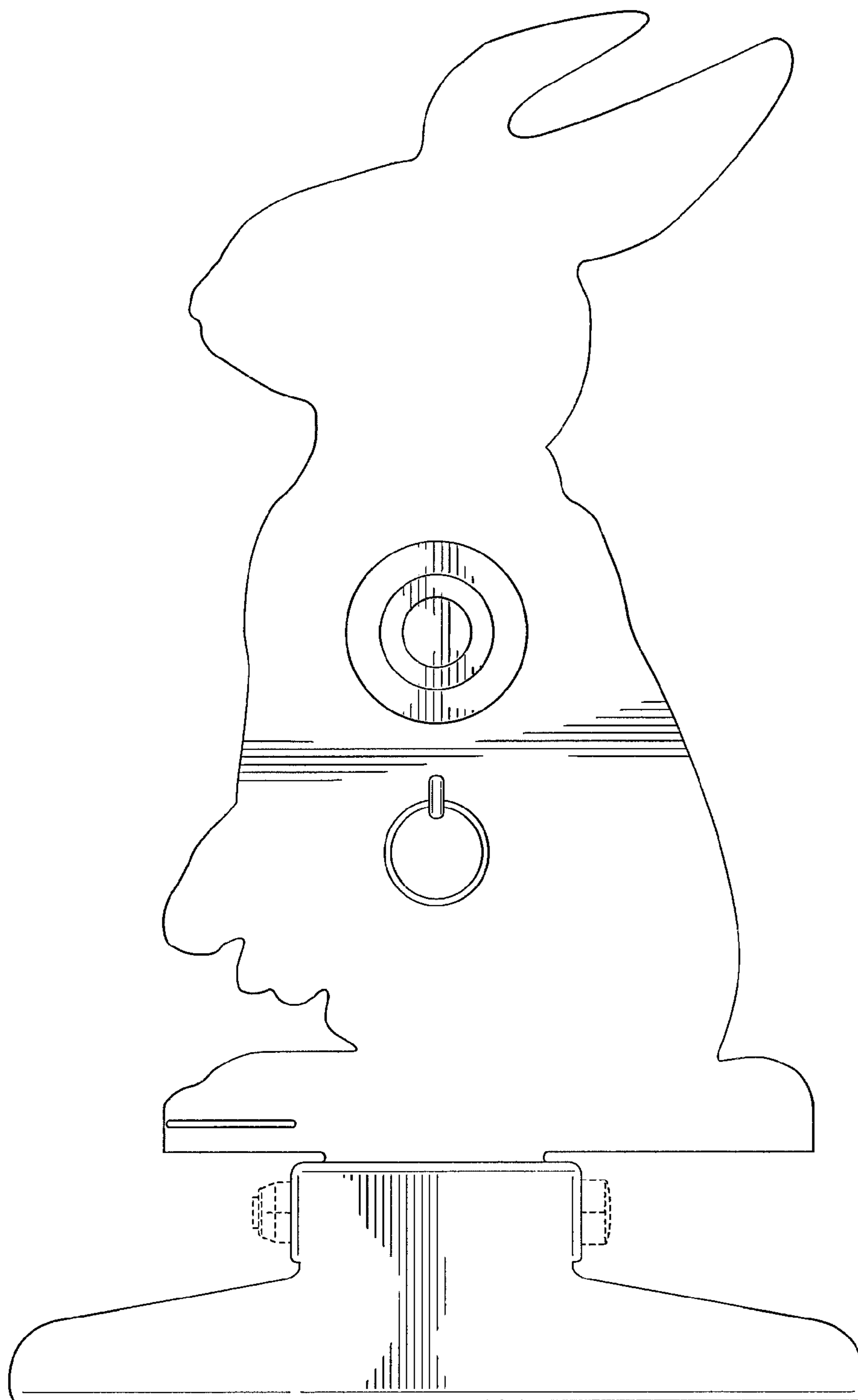

FIG. 3

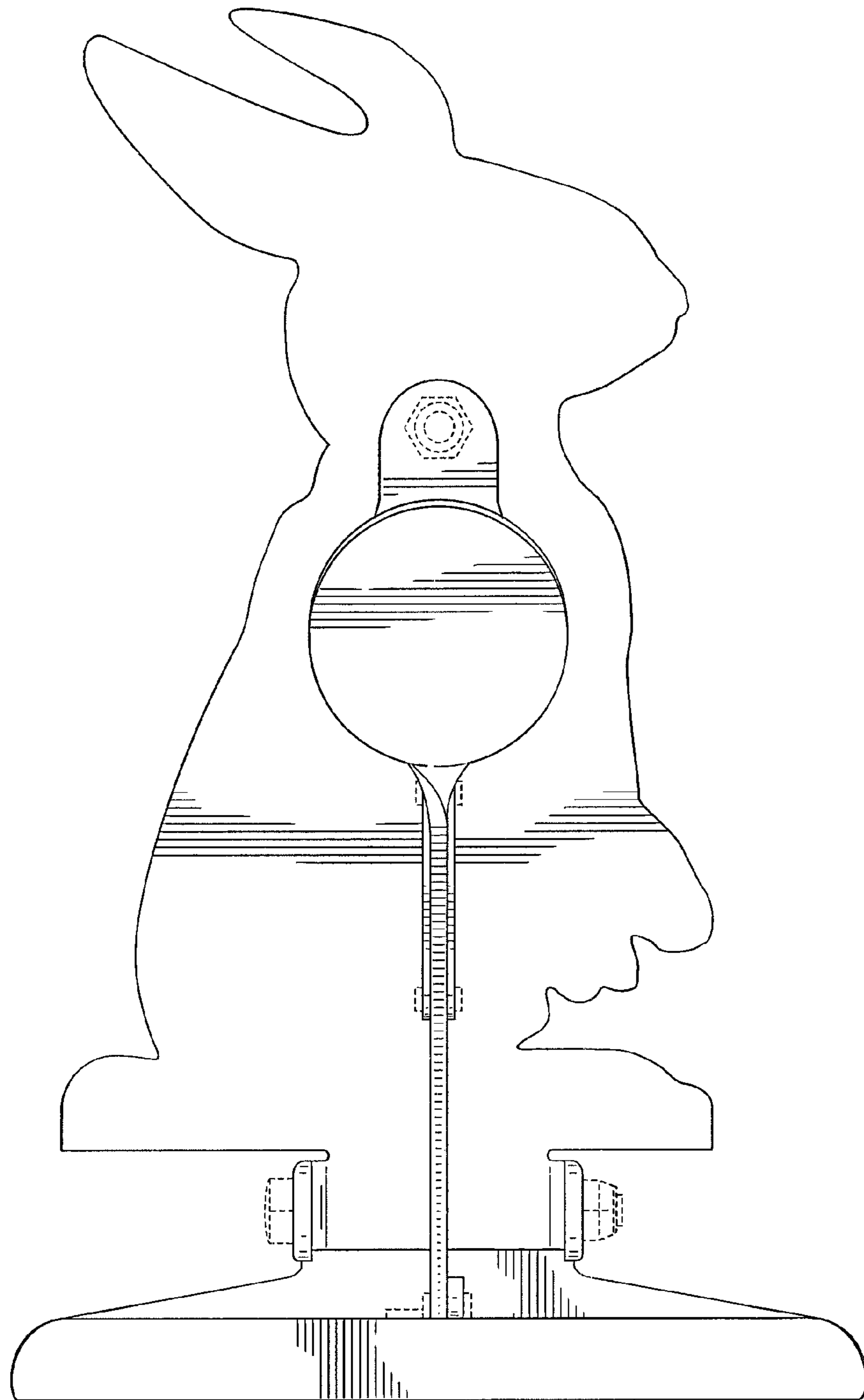

FIG. 4

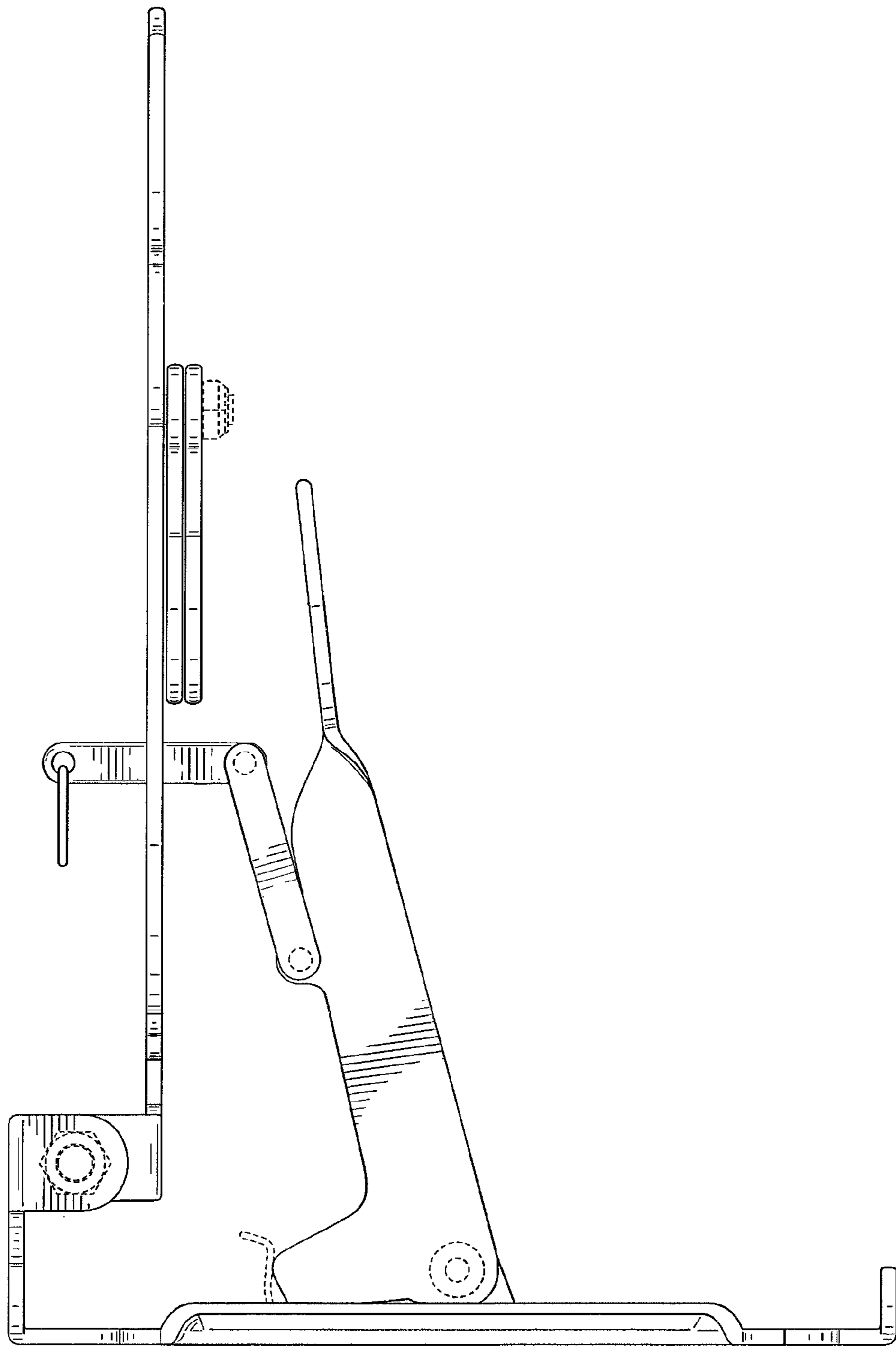

FIG. 5

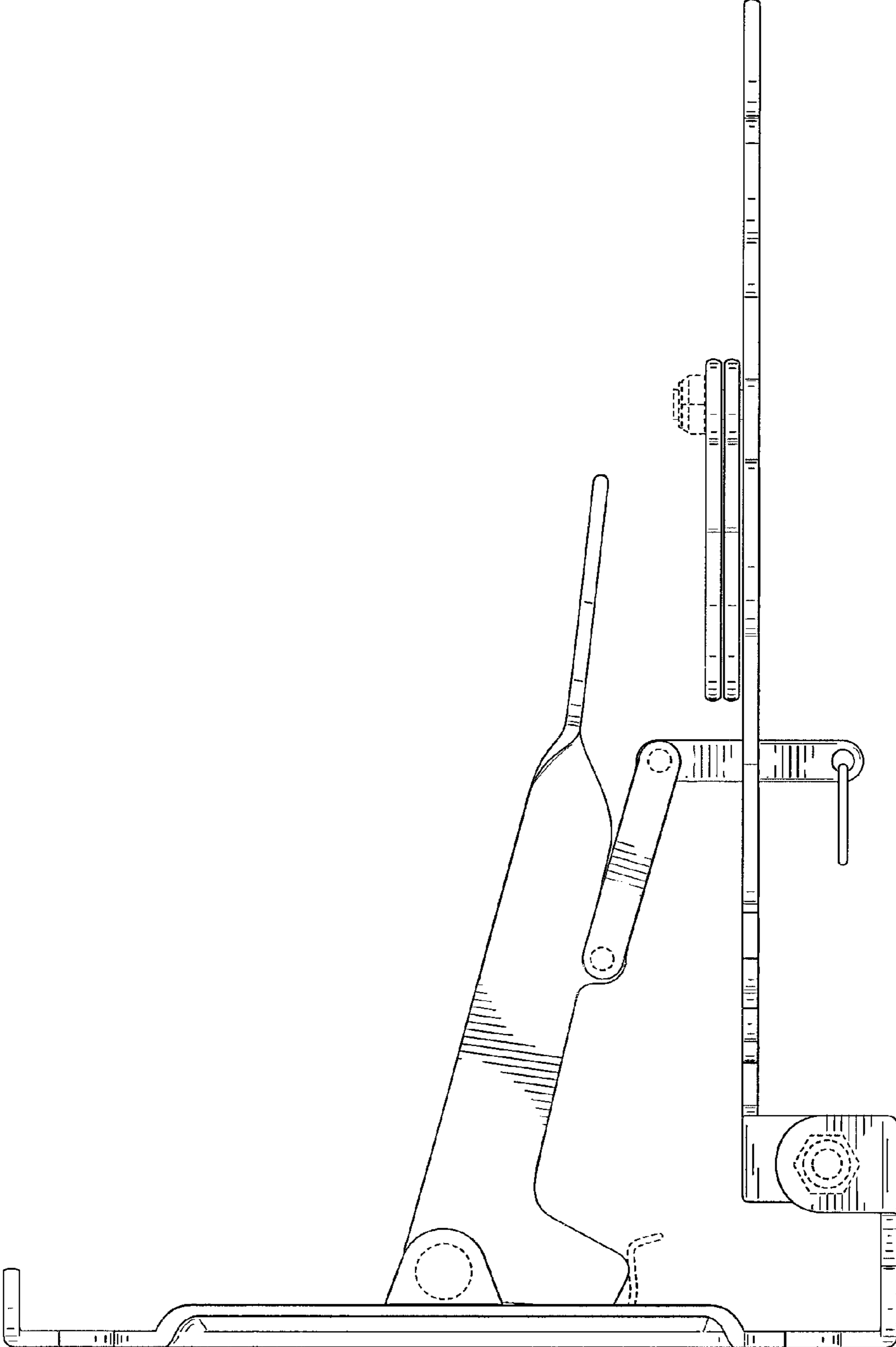

FIG. 6

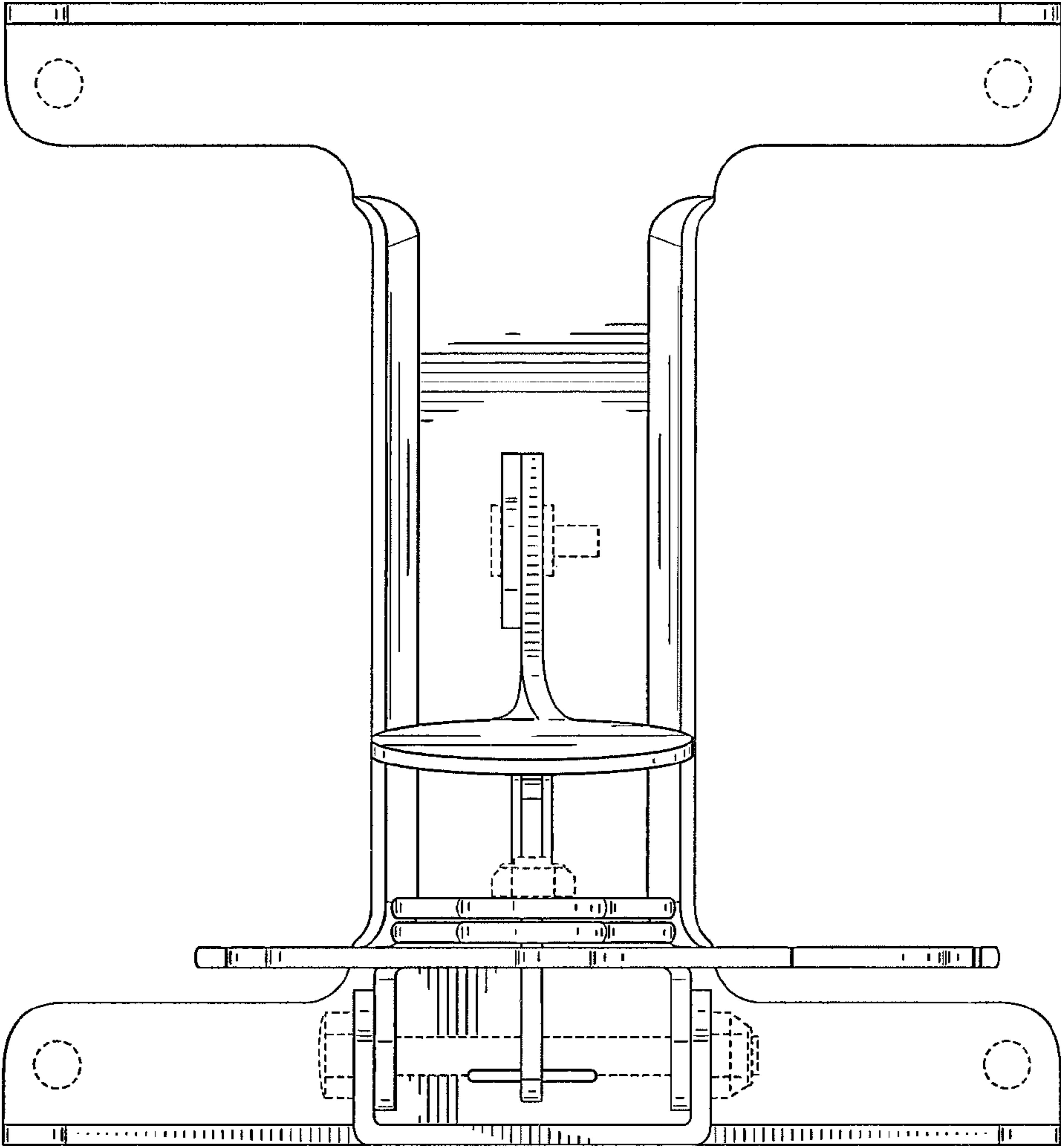

FIG. 7

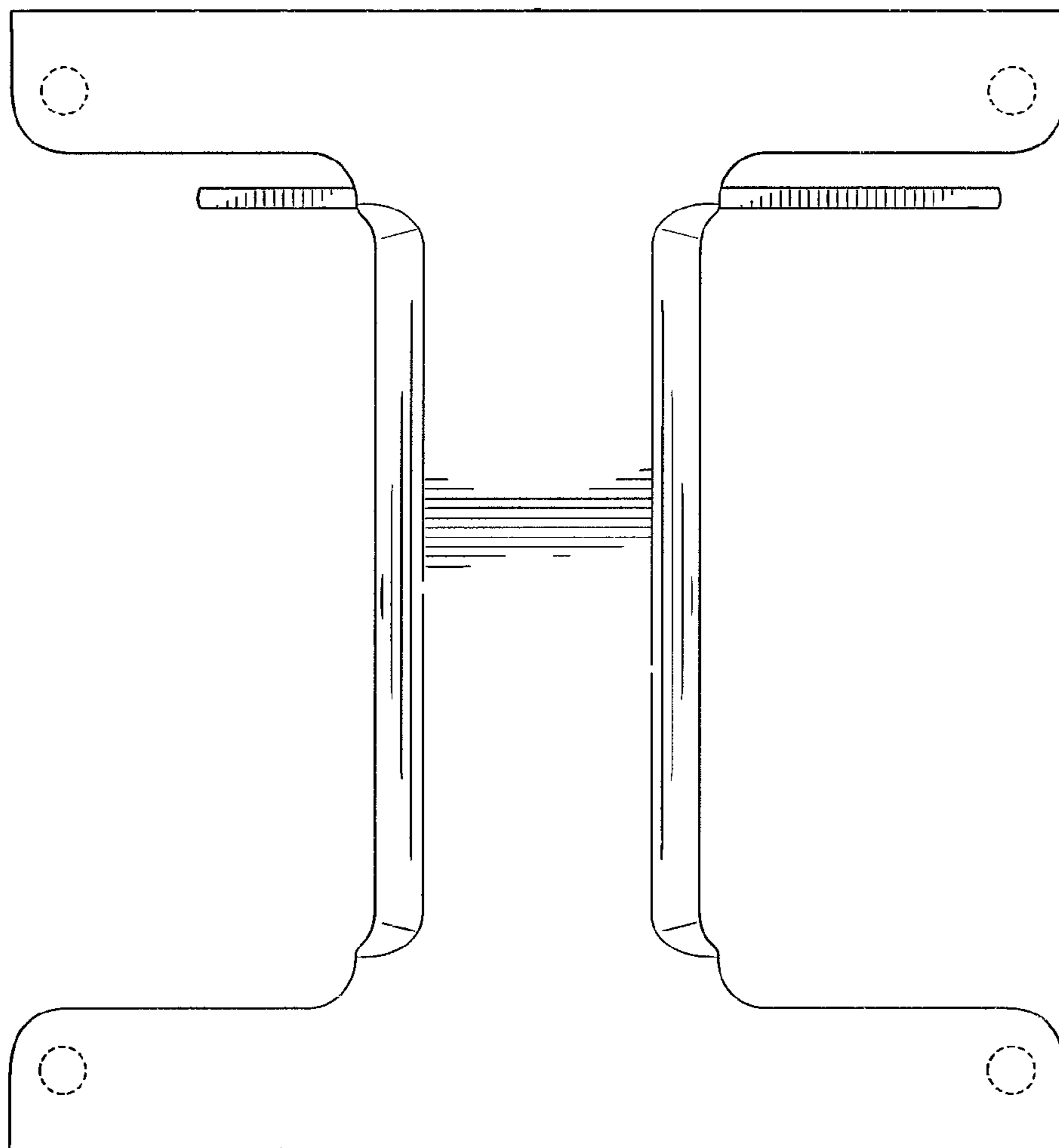

FIG. 8

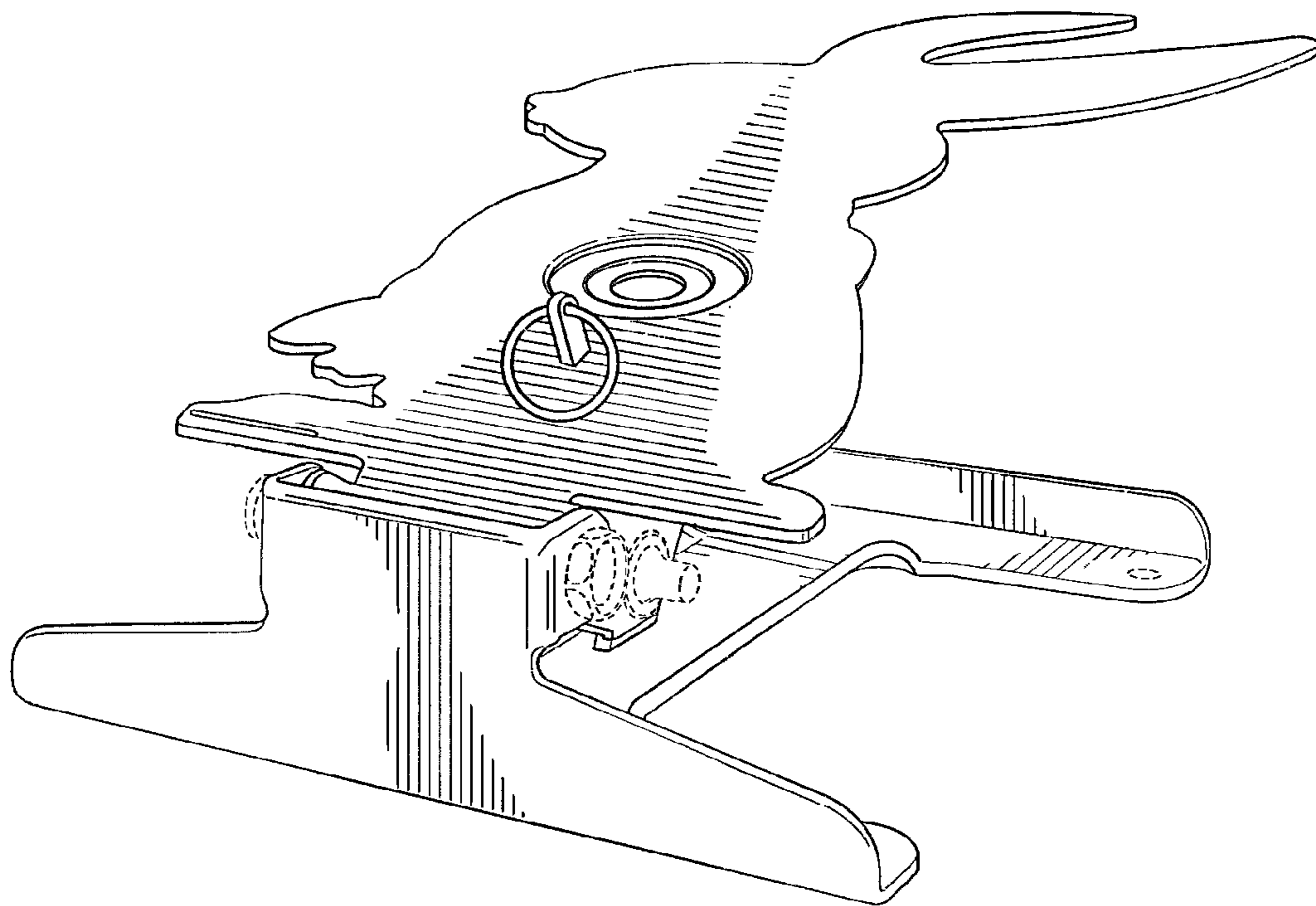

FIG. 9

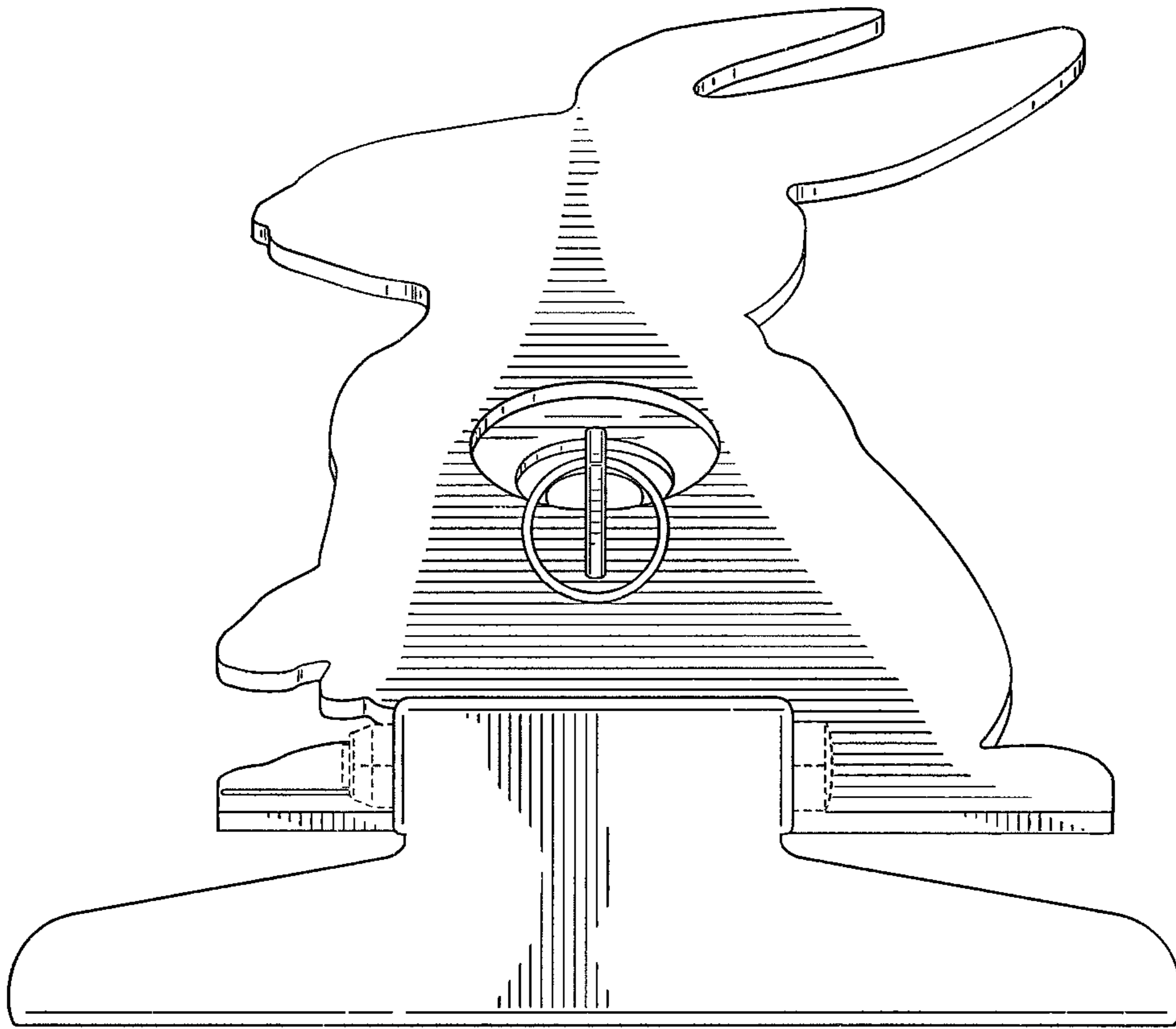

FIG. 10

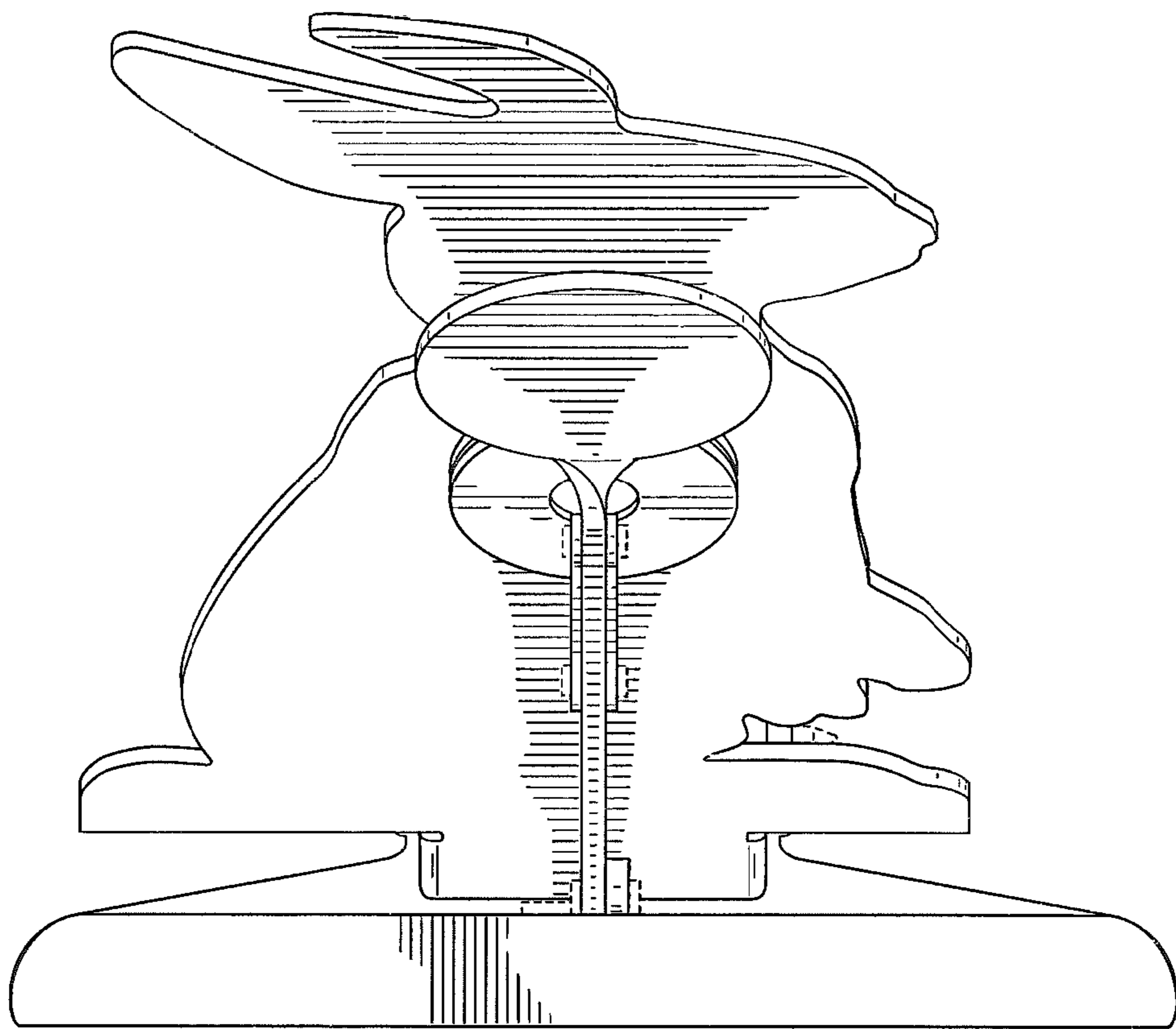

FIG. 11

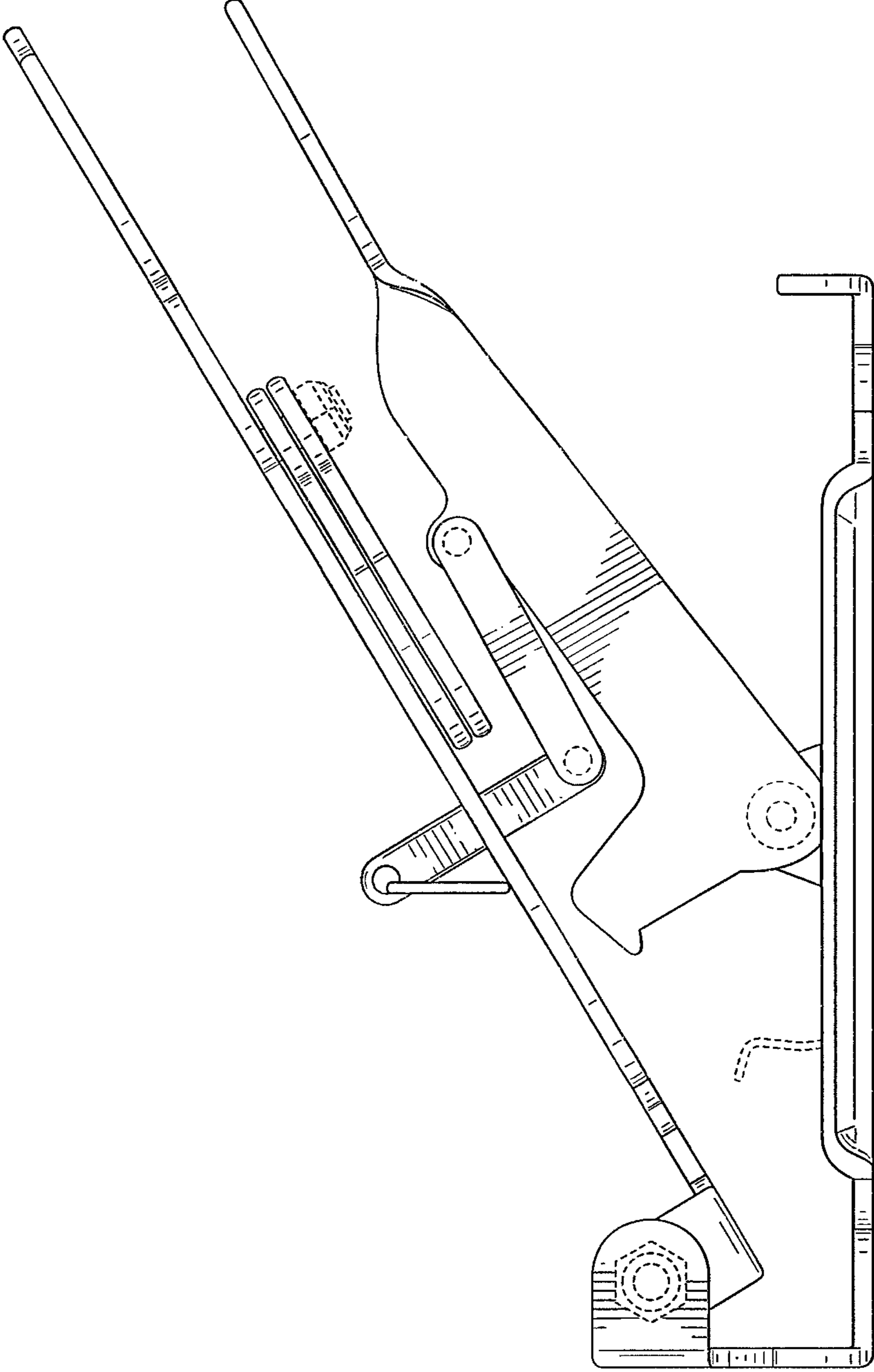

FIG. 12

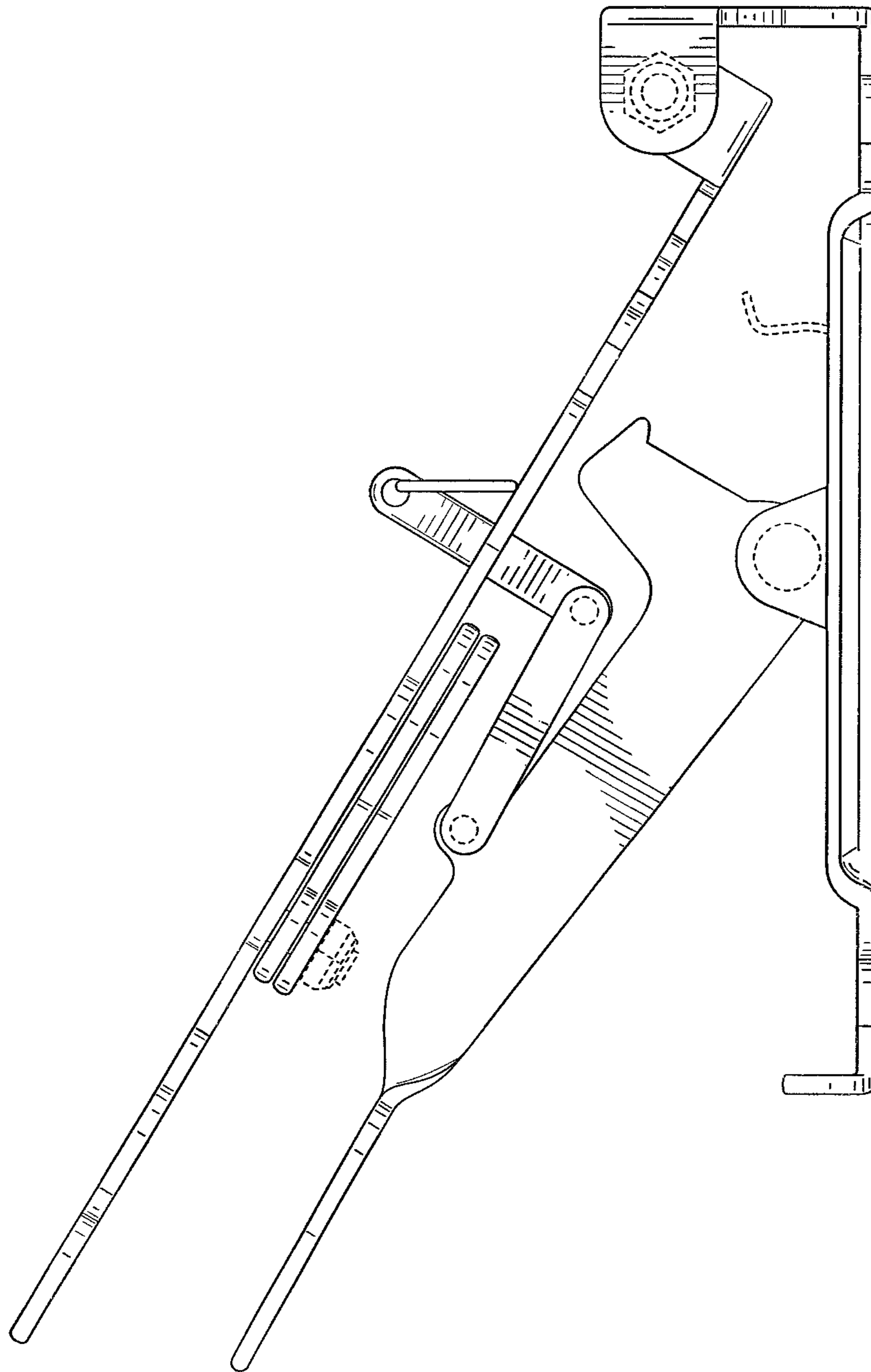

FIG. 13

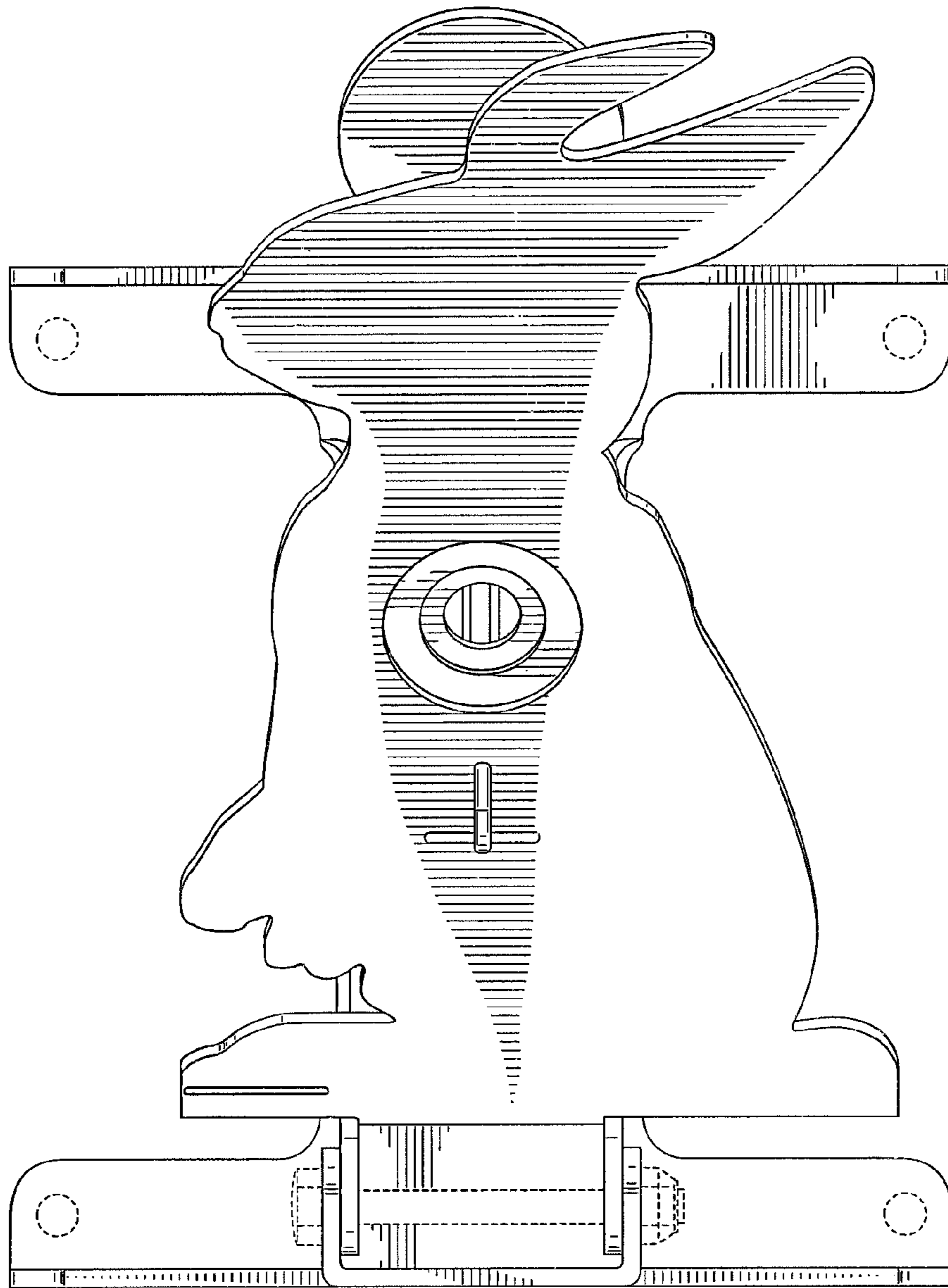

FIG. 14

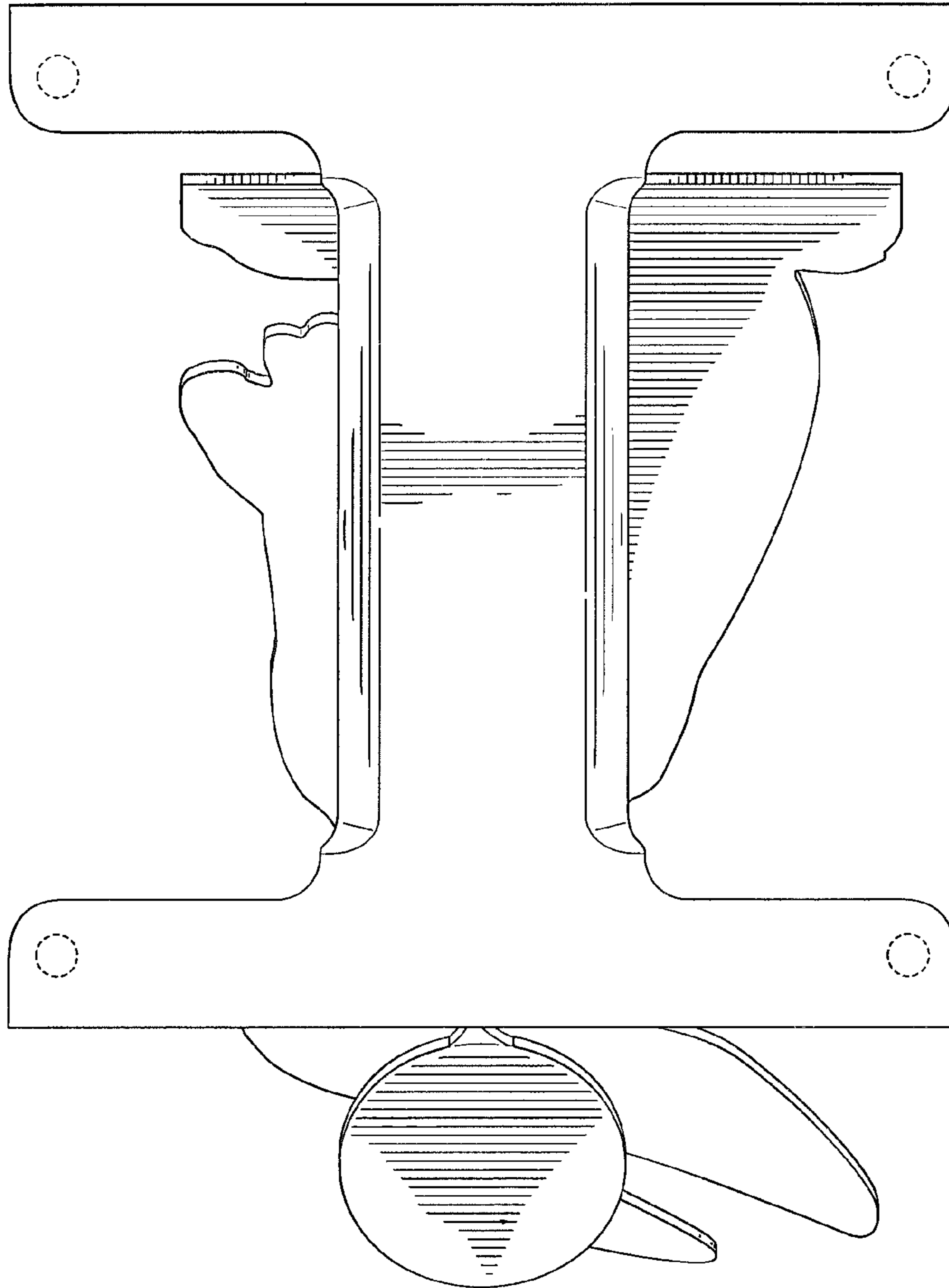

FIG. 15

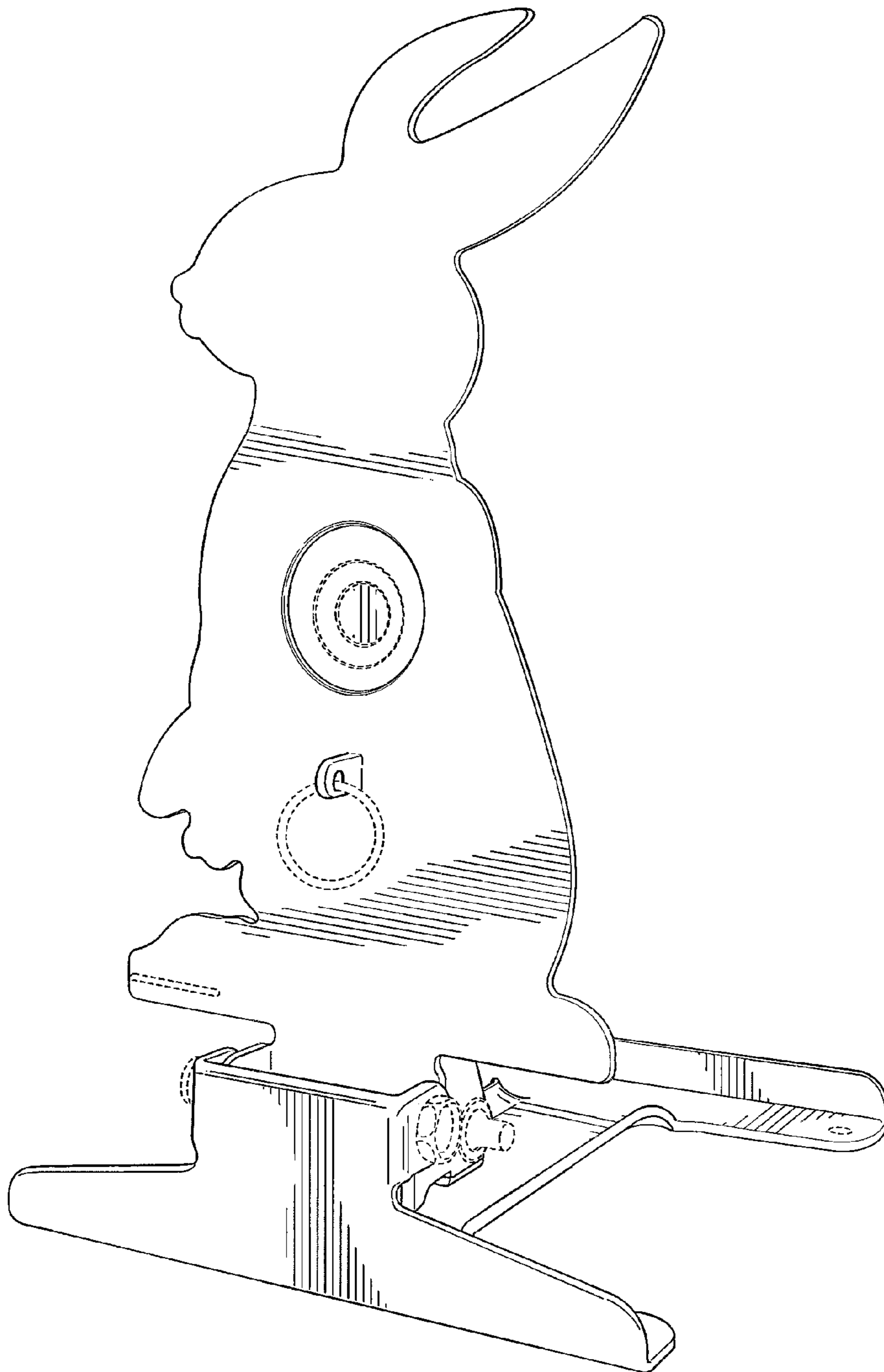

FIG. 16

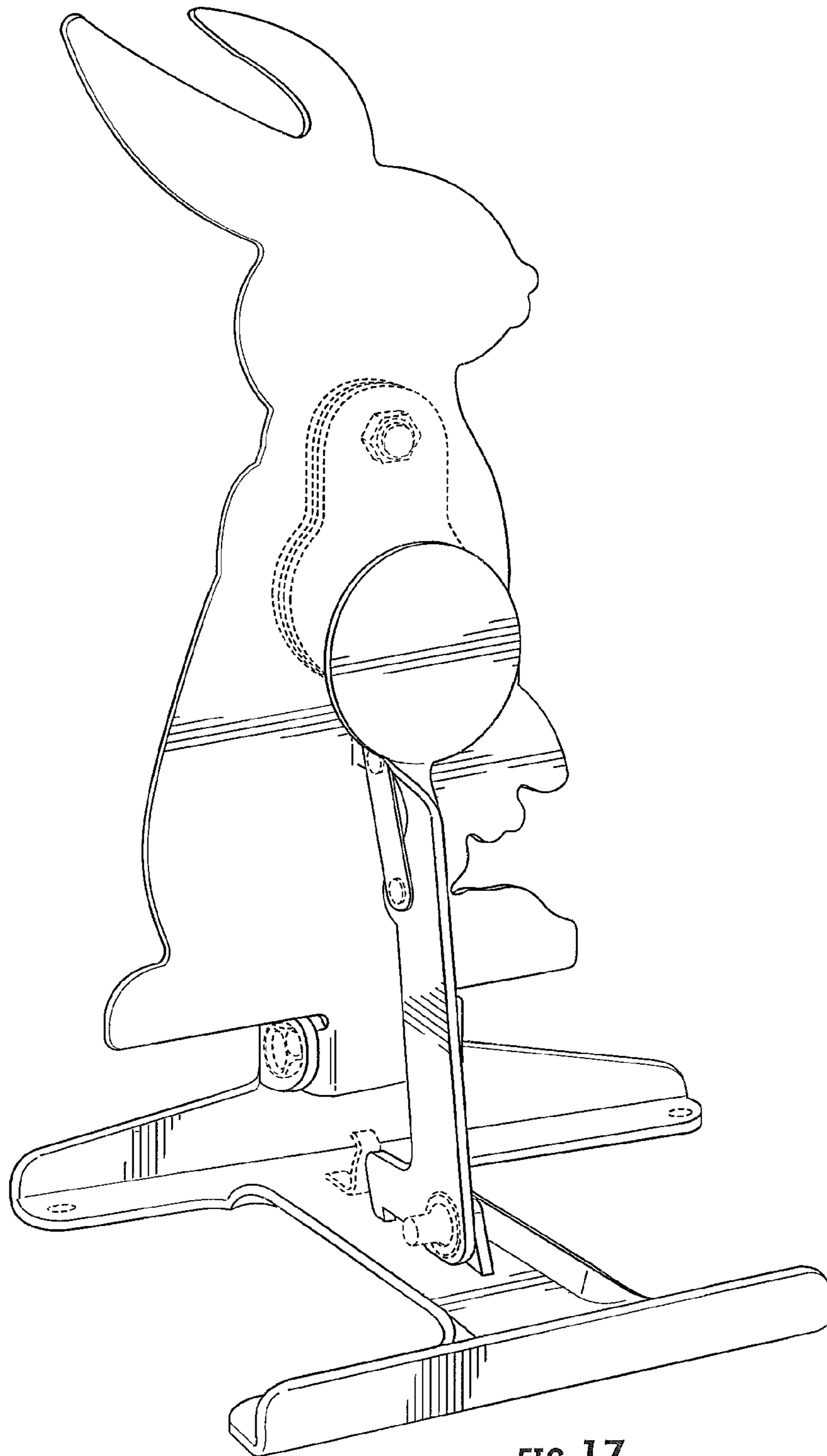

FIG. 17

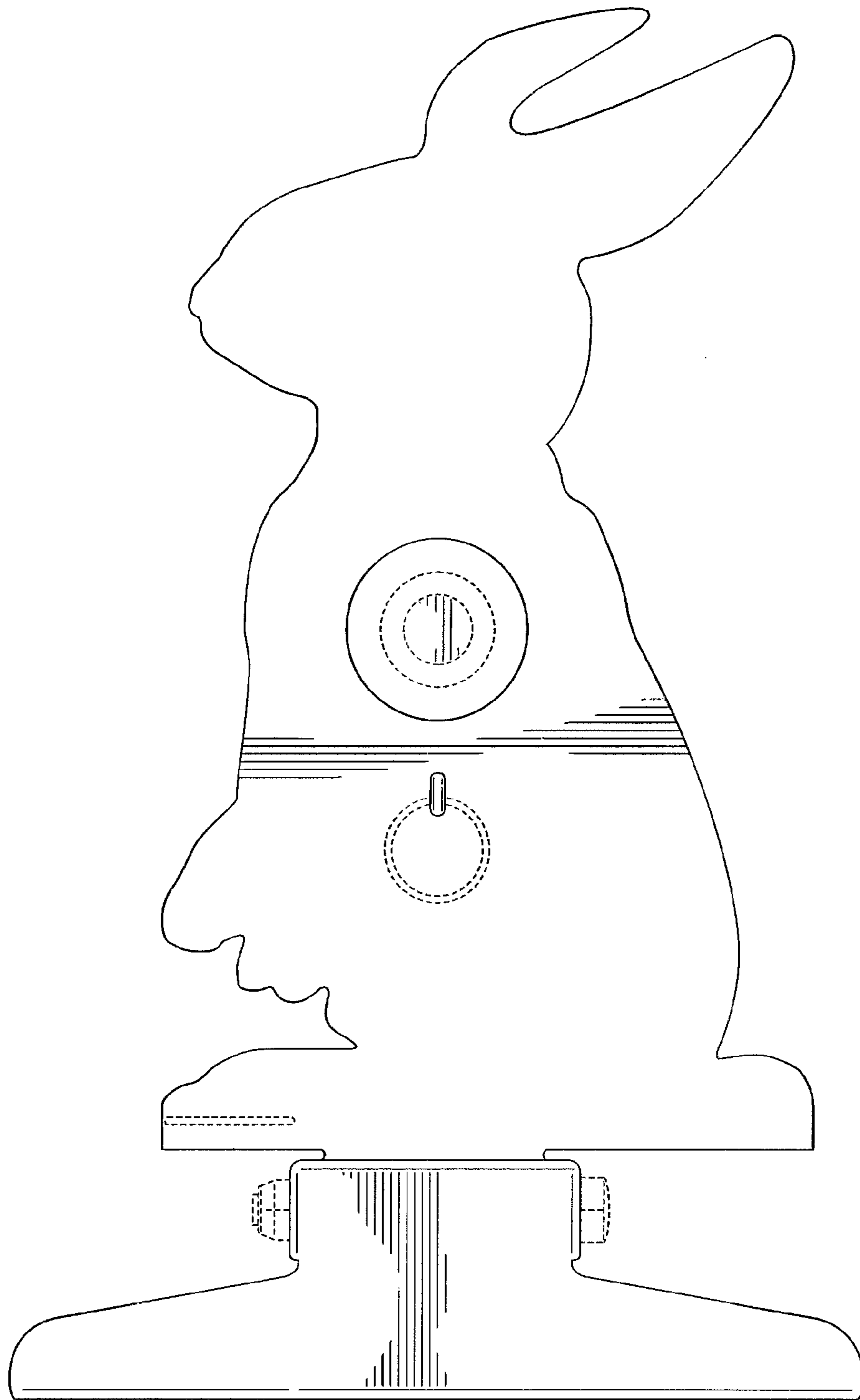

FIG. 18

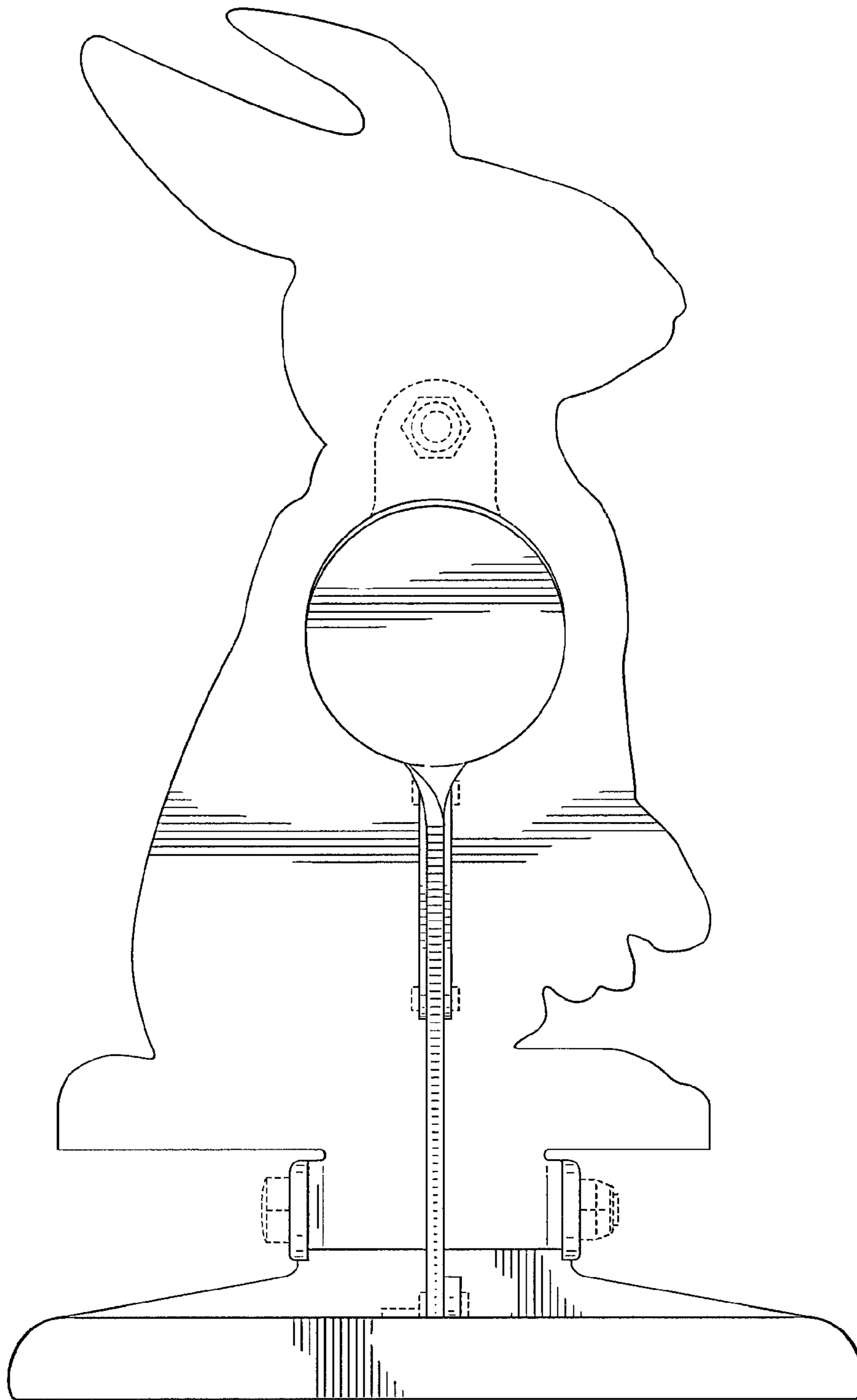

FIG. 19

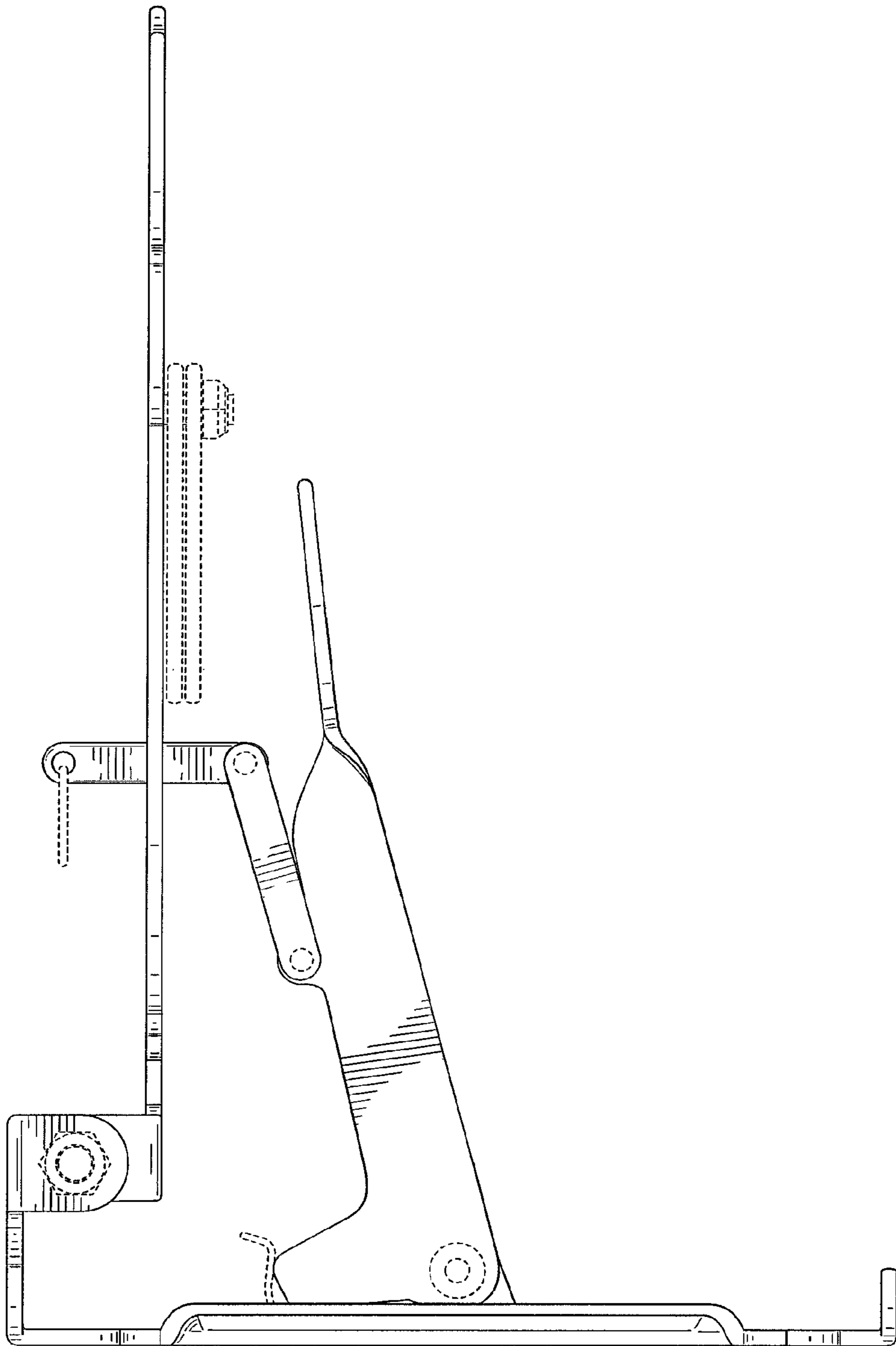

FIG. 20

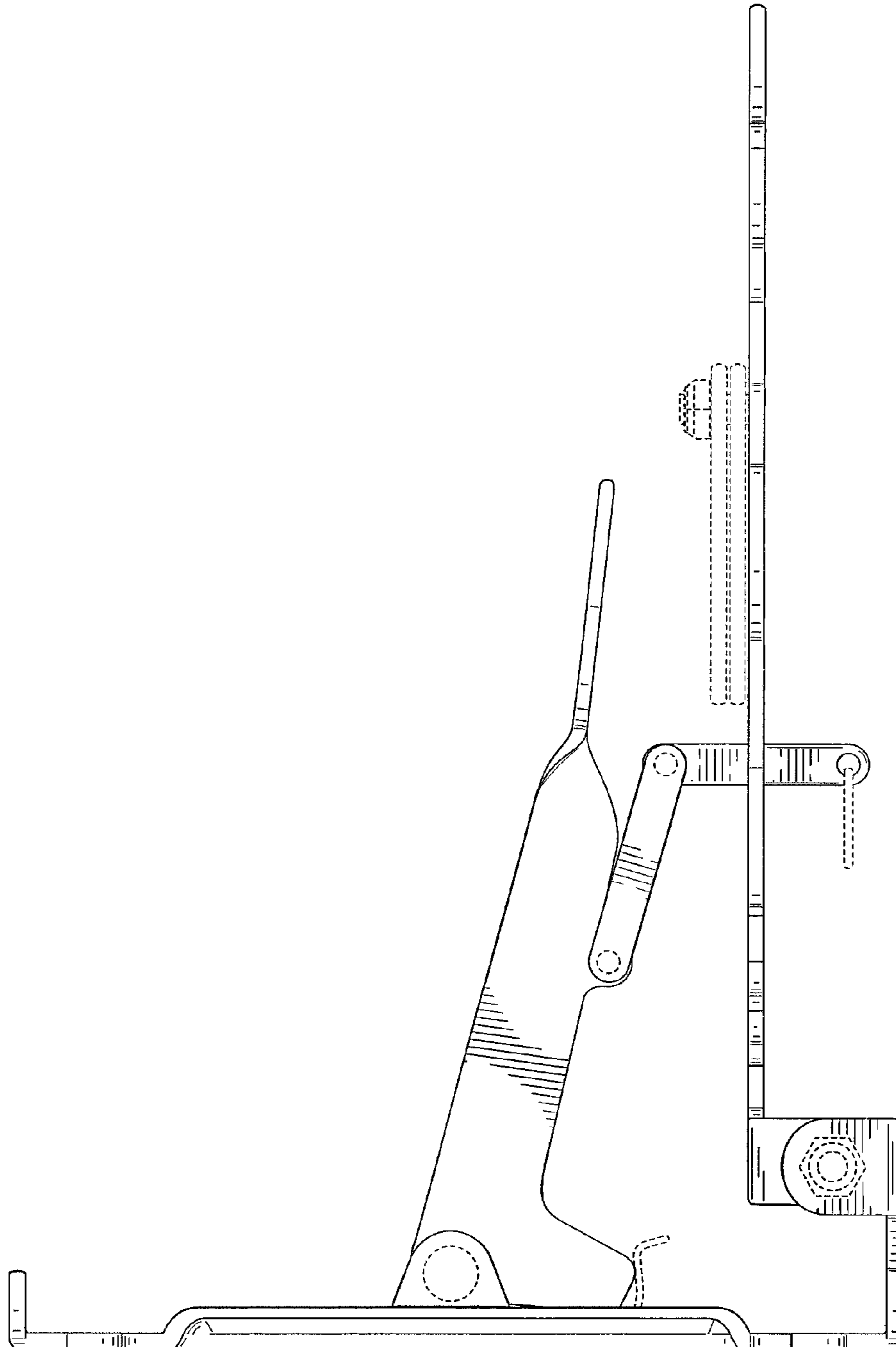

FIG. 21

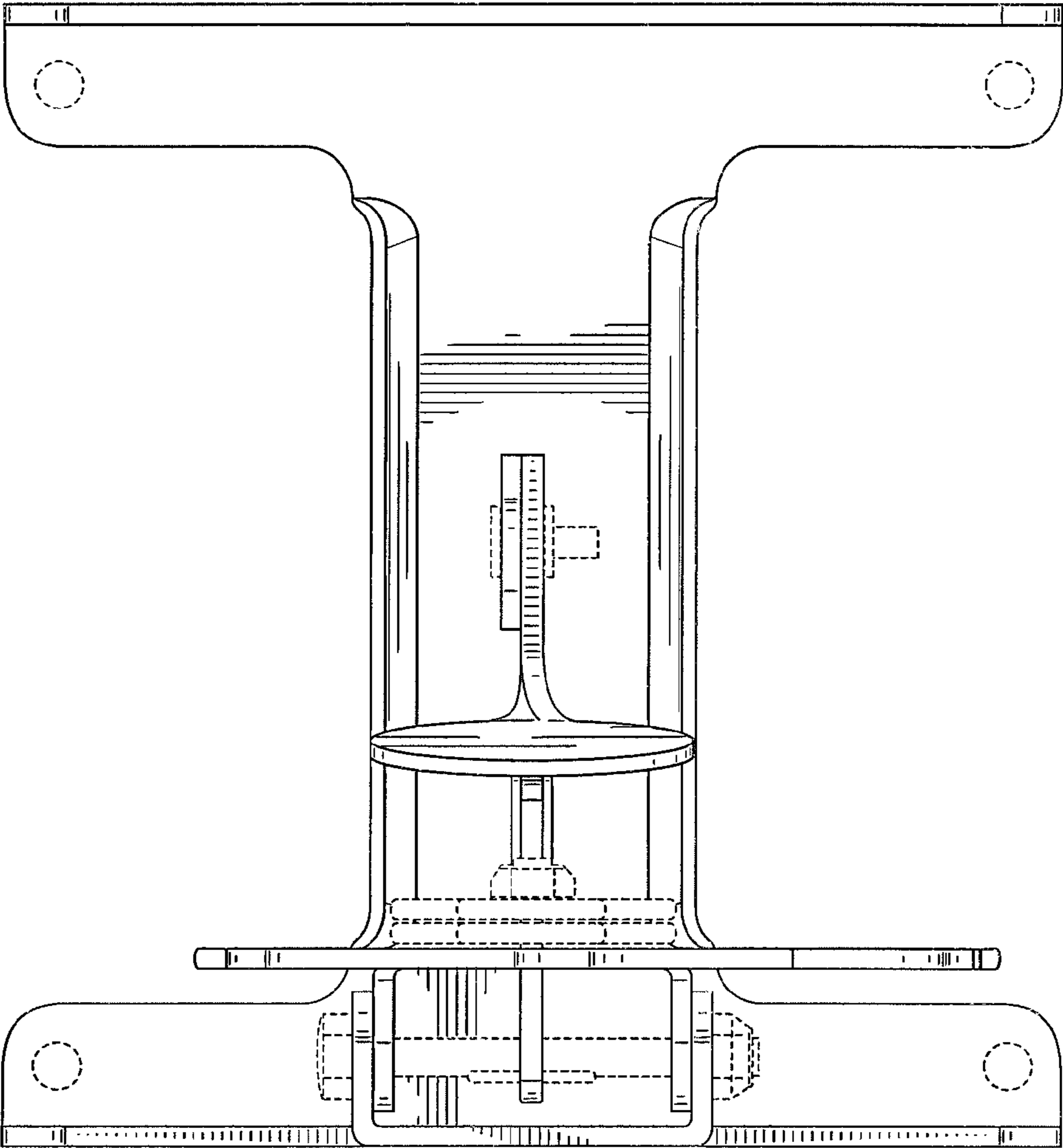

FIG. 22

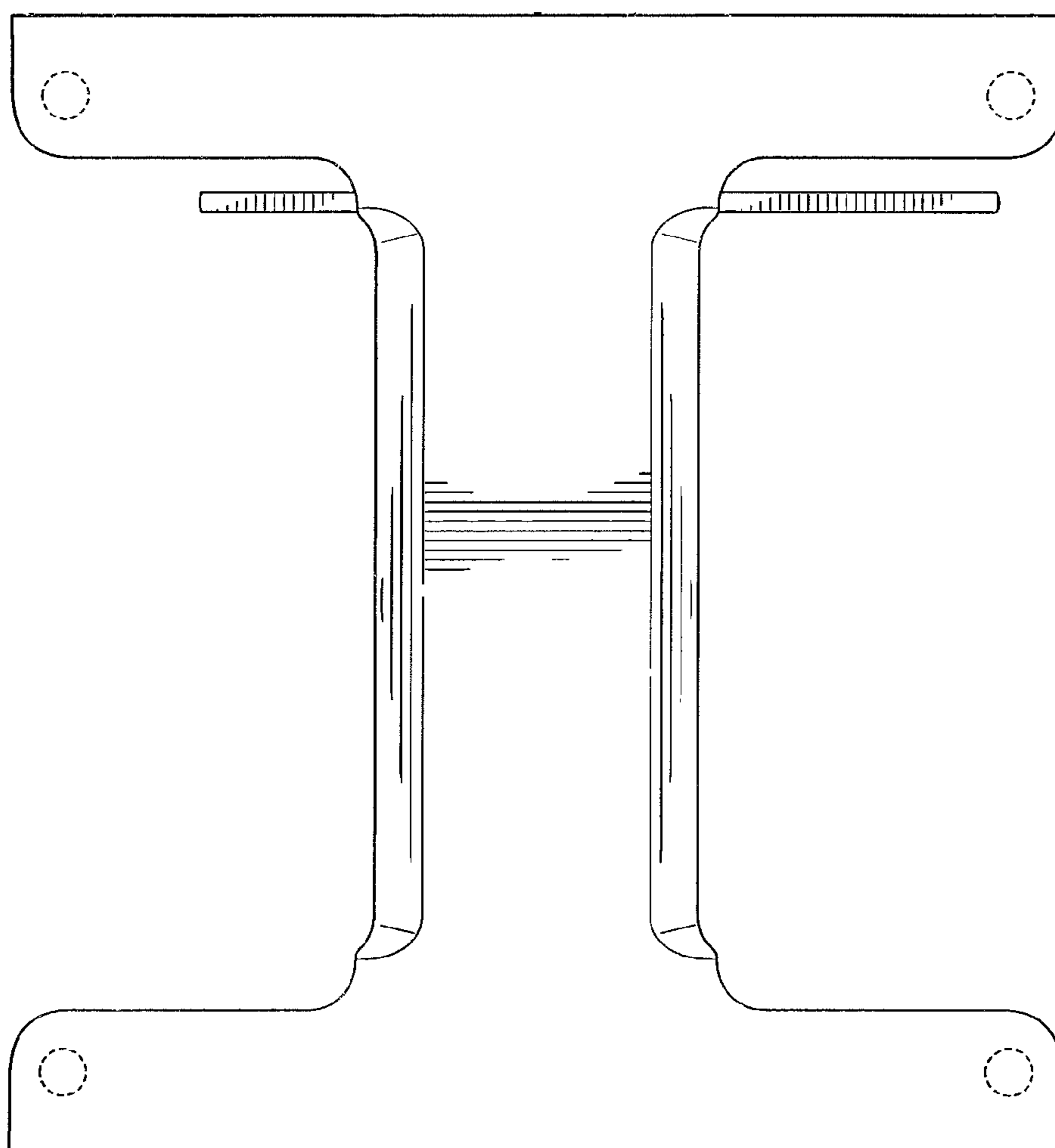

FIG. 23

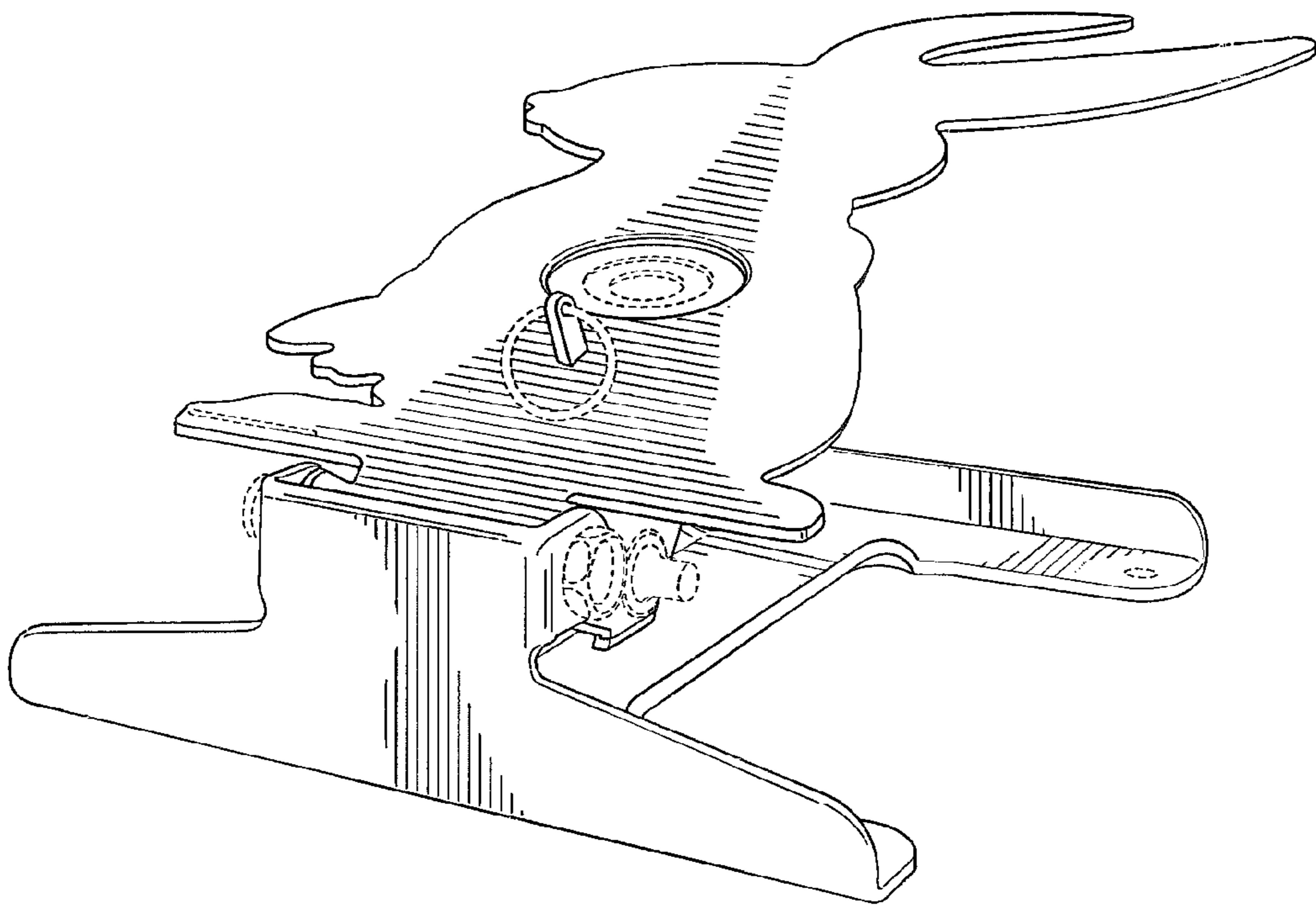

FIG. 24

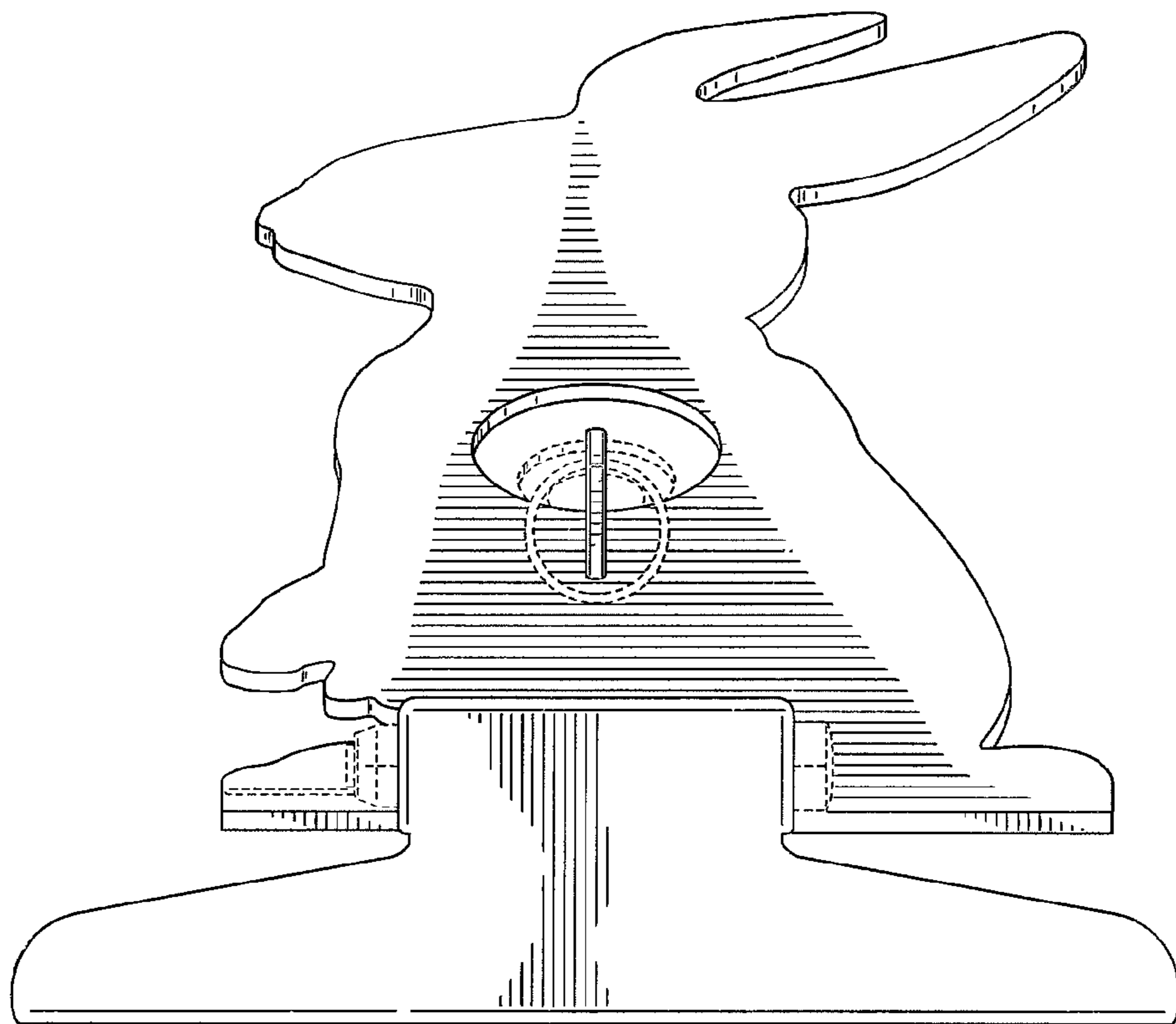

FIG. 25

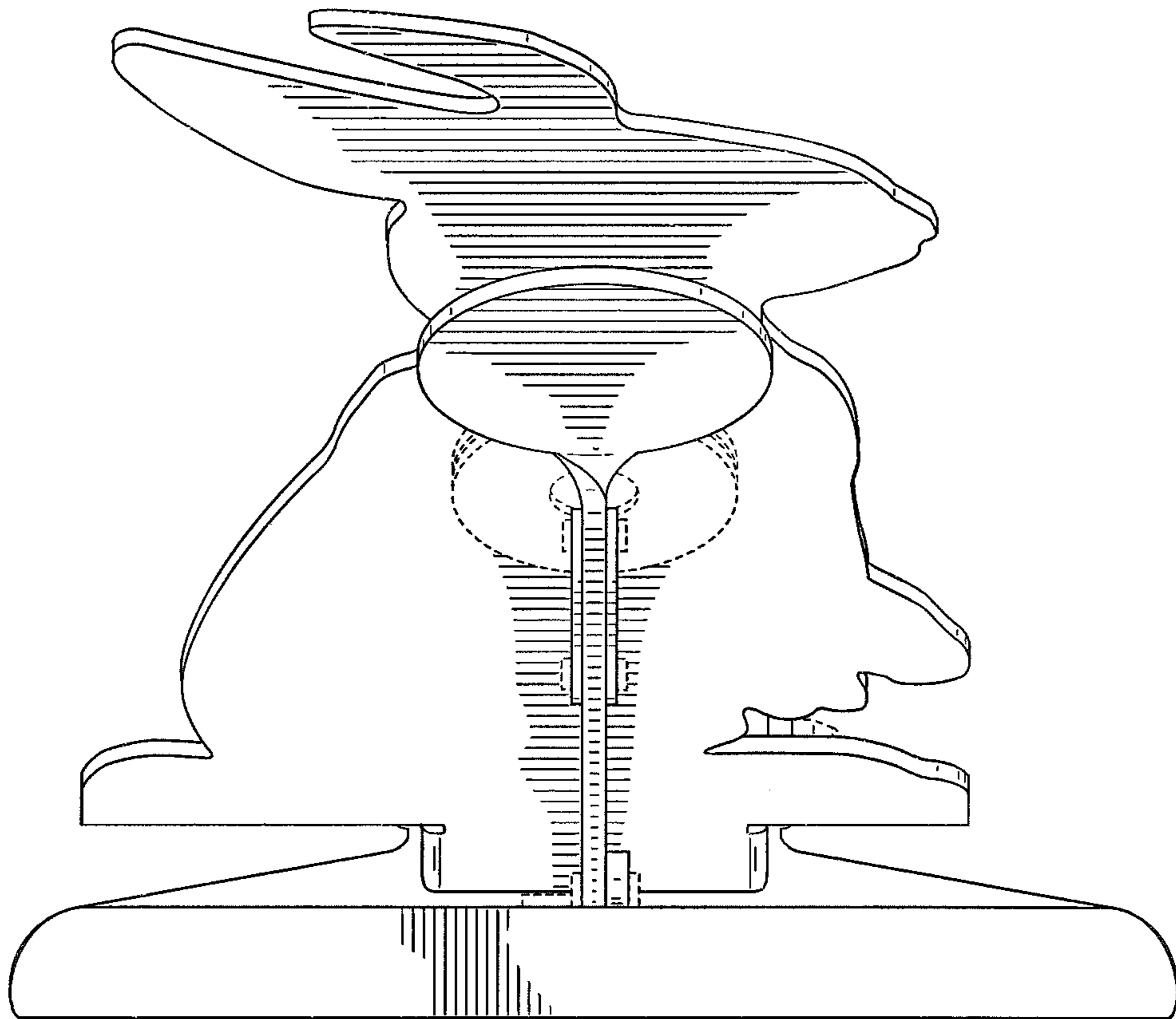

FIG. 26

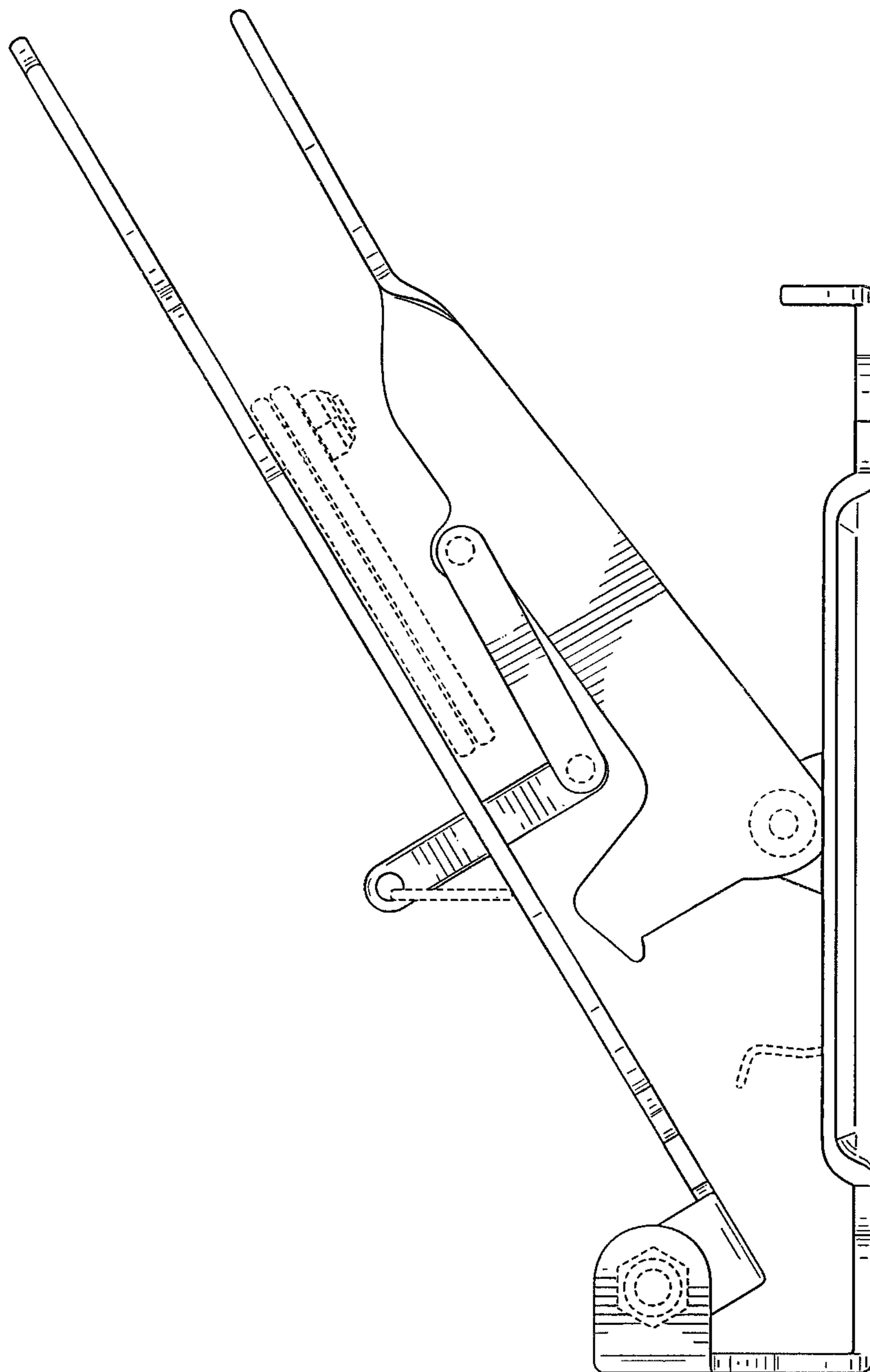

FIG. 27

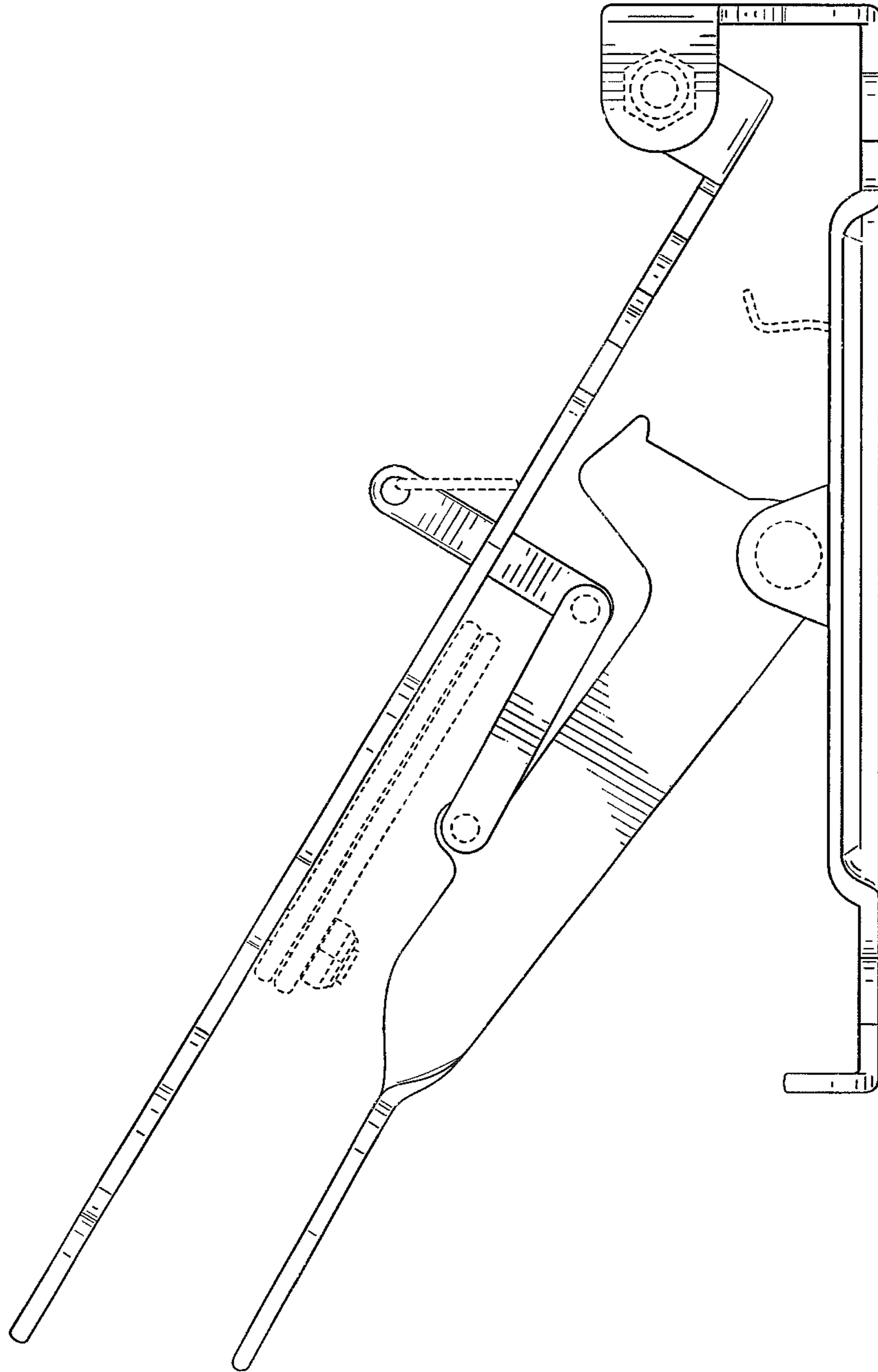

FIG. 28

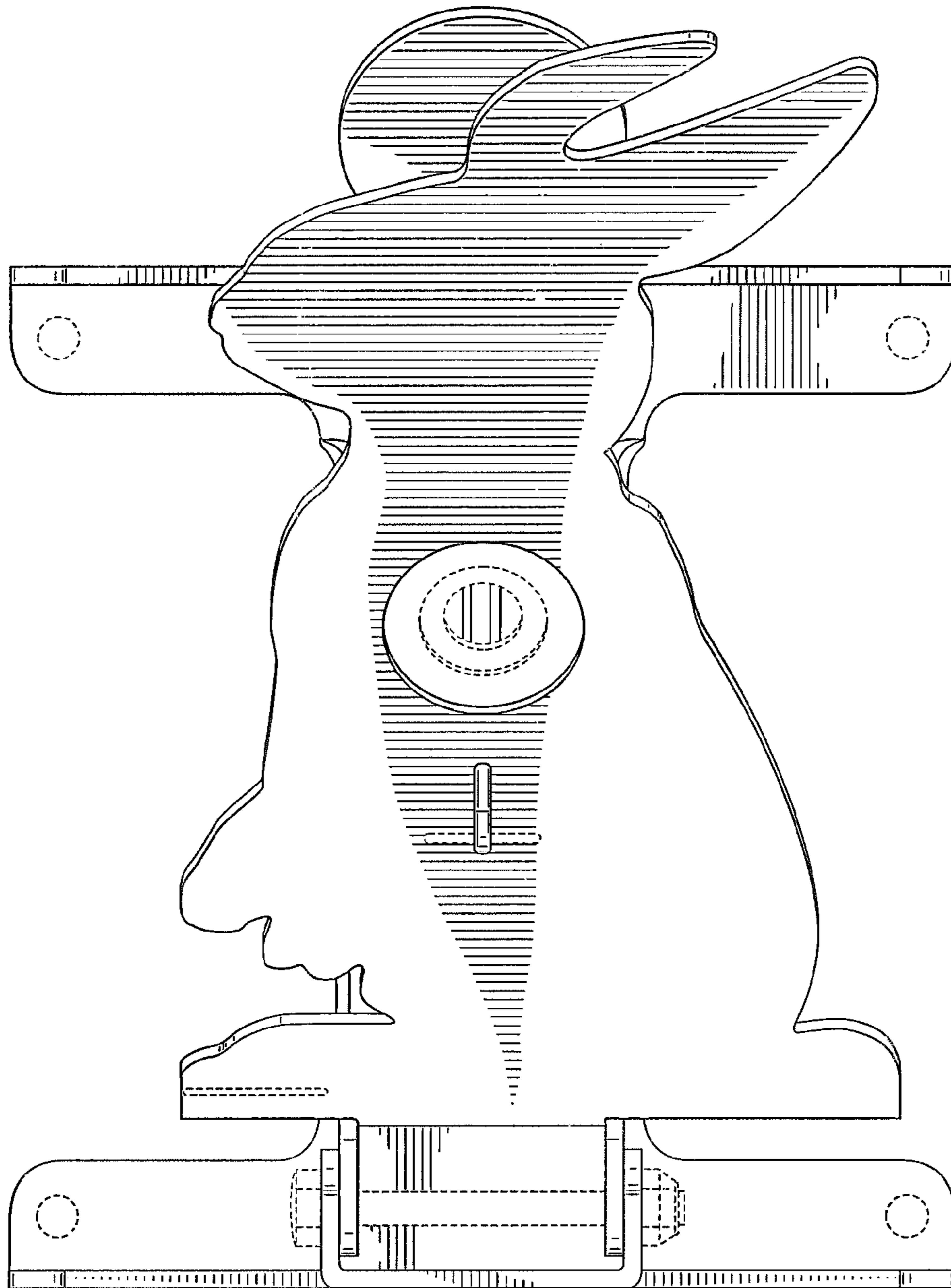

FIG. 29

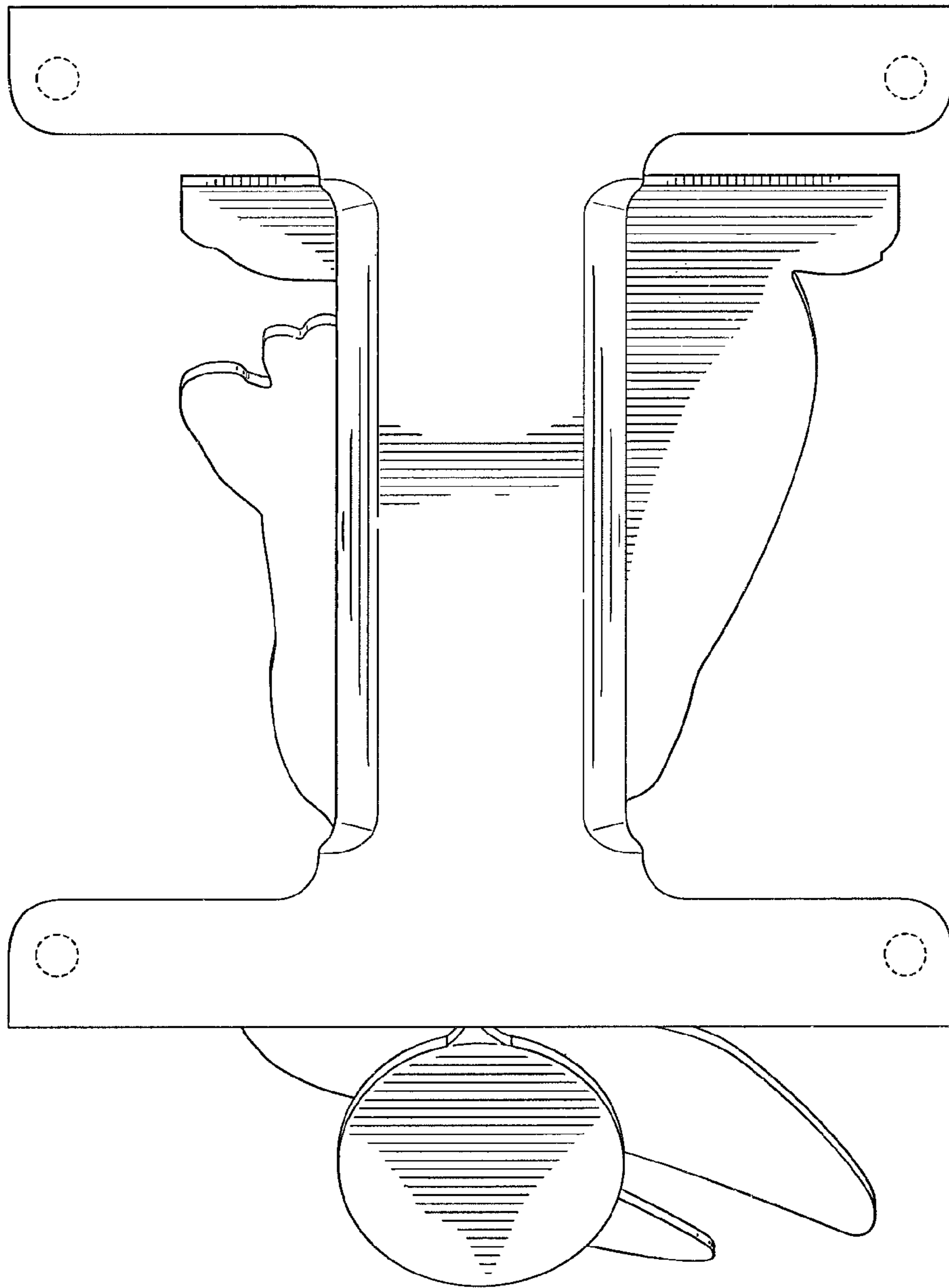

FIG. 30