



US00D744027S

(12) **United States Design Patent**
Fonterrada

(10) **Patent No.:** **US D744,027 S**

(45) **Date of Patent:** **** Nov. 24, 2015**

(54) **STRINGED MUSICAL INSTRUMENT**

(76) Inventor: **Fernando Civolani Fonterrada**, São Paulo (BR)

(**) Term: **14 Years**

(21) Appl. No.: **29/420,962**

(22) Filed: **May 15, 2012**

(30) **Foreign Application Priority Data**

Nov. 16, 2011 (BR) 7105712

(51) **LOC (10) CL.** **17-03**

(52) **U.S. CL.**
USPC **D17/14**

(58) **Field of Classification Search**
USPC D17/14, 17, 19; 84/173, 267, 268, 269, 84/274

See application file for complete search history.

(56) **References Cited**

U.S. PATENT DOCUMENTS

568,108	A	*	9/1896	Brown	84/263
D43,684	S	*	3/1913	Weymann	D17/19
D44,838	S	*	11/1913	Day	D17/19
1,650,112	A	*	11/1927	Charlston	84/268
2,083,751	A	*	6/1937	Thompson	84/267
2,449,124	A	*	9/1948	Kimmons	84/267
3,822,628	A	*	7/1974	Quemore, Sr.	84/275
4,147,084	A	*	4/1979	Underwood	84/731
D281,700	S	*	12/1985	Egnatski	D17/19
D489,395	S	*	5/2004	Sewell	D17/14

D522,041	S	*	5/2006	Sewell	D17/14
D606,582	S	*	12/2009	Philipp et al.	D17/19
D612,414	S	*	3/2010	Mills et al.	D17/14

OTHER PUBLICATIONS

Pinterest. <https://www.pinterest.com/alexeystadnik/upright-bass/>.
Date Unknown: Viewed Dec. 2014. "Bass Fiddle".*
3-String Guitars. <http://www.3-string-guitar.com/2009/09/3-string-bass-upright-history.html>. Sep. 2009. "3 string bass Upright".*

* cited by examiner

Primary Examiner — Rashida Johnson

(74) *Attorney, Agent, or Firm* — Nixon & Vanderhye P.C.

(57) **CLAIM**

The ornamental design for a "stringed musical instrument," as shown and described.

DESCRIPTION

FIG. 1 is a front perspective view of a stringed musical instrument which embodies my new design;
FIG. 2 is a front elevational view thereof;
FIG. 3 is a sectional view taken at line 3 in FIG. 2;
FIG. 4 is a rear elevational view thereof;
FIG. 5 is a right side elevational view thereof;
FIG. 6 is a left side elevational view thereof;
FIG. 7 is a top plan view thereof; and,
FIG. 8 is a bottom plan view thereof.
In FIGS. 1-3, the broken lines represent the portions of the stringed musical instrument that form no part of the claimed design.

1 Claim, 5 Drawing Sheets

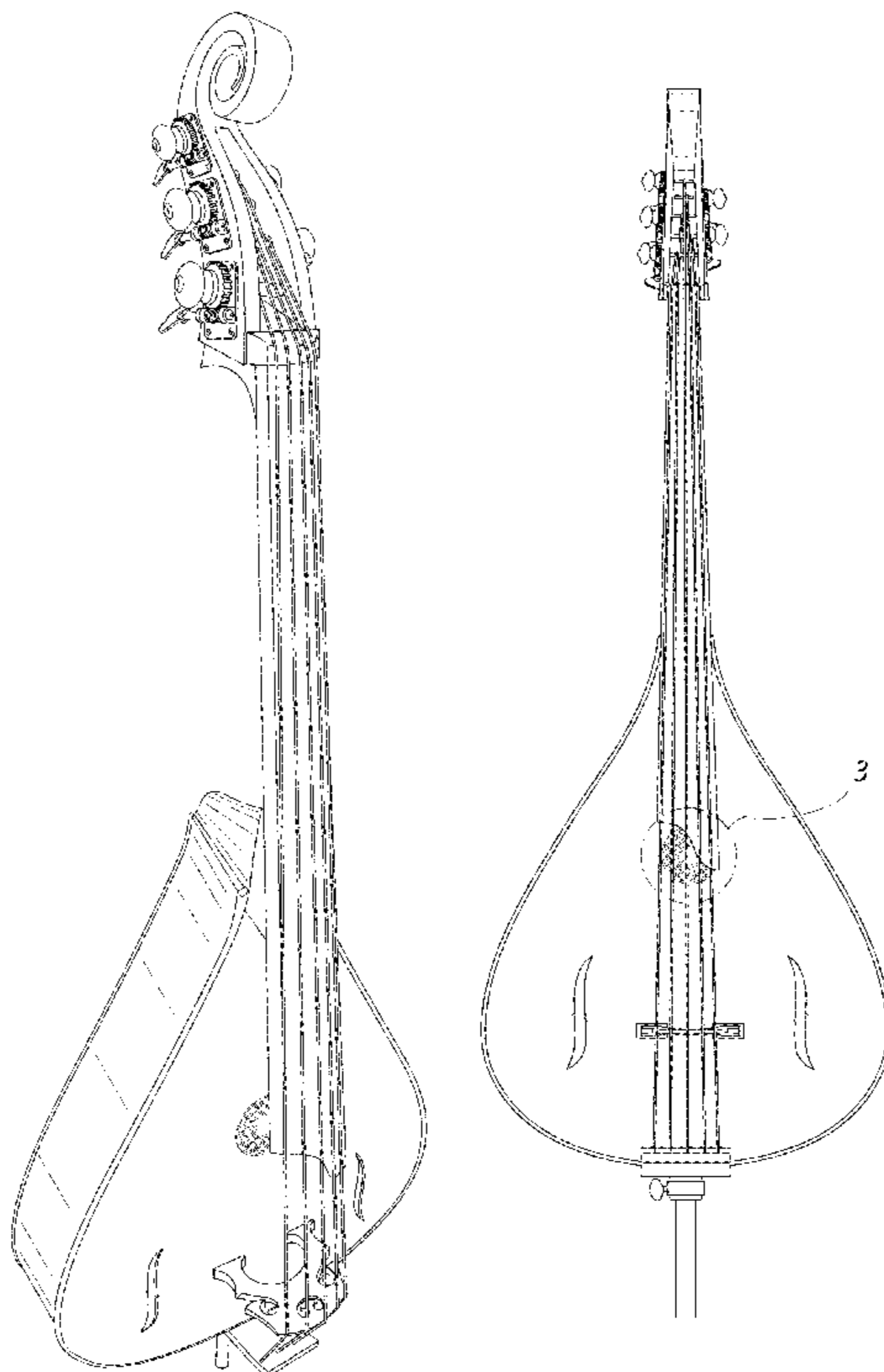

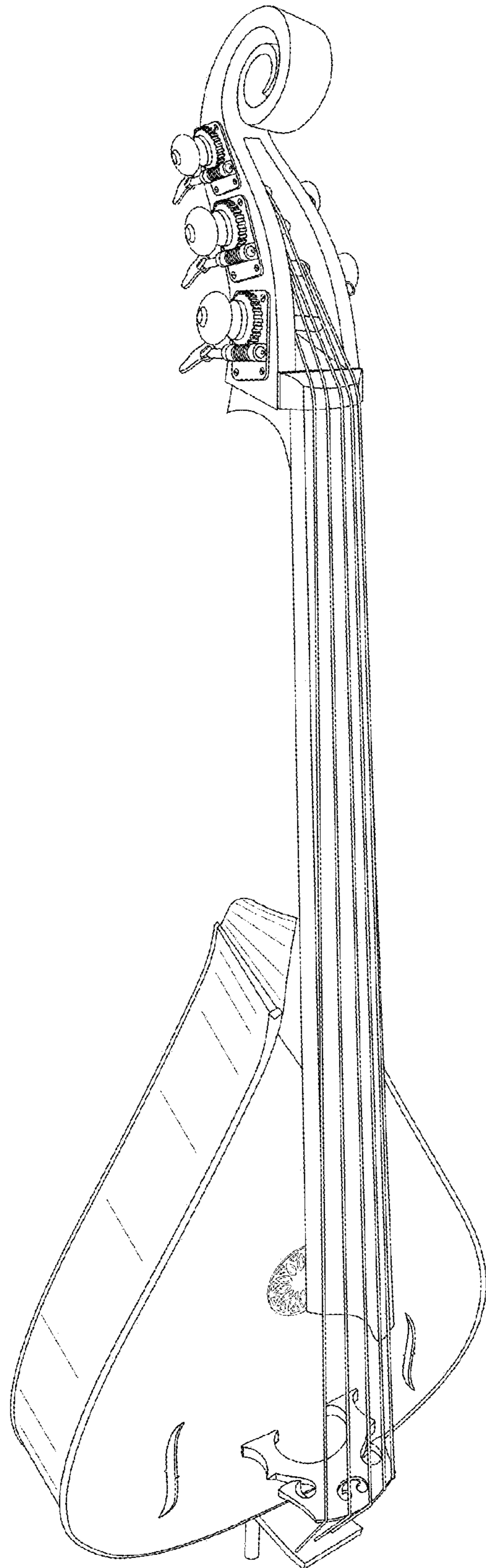
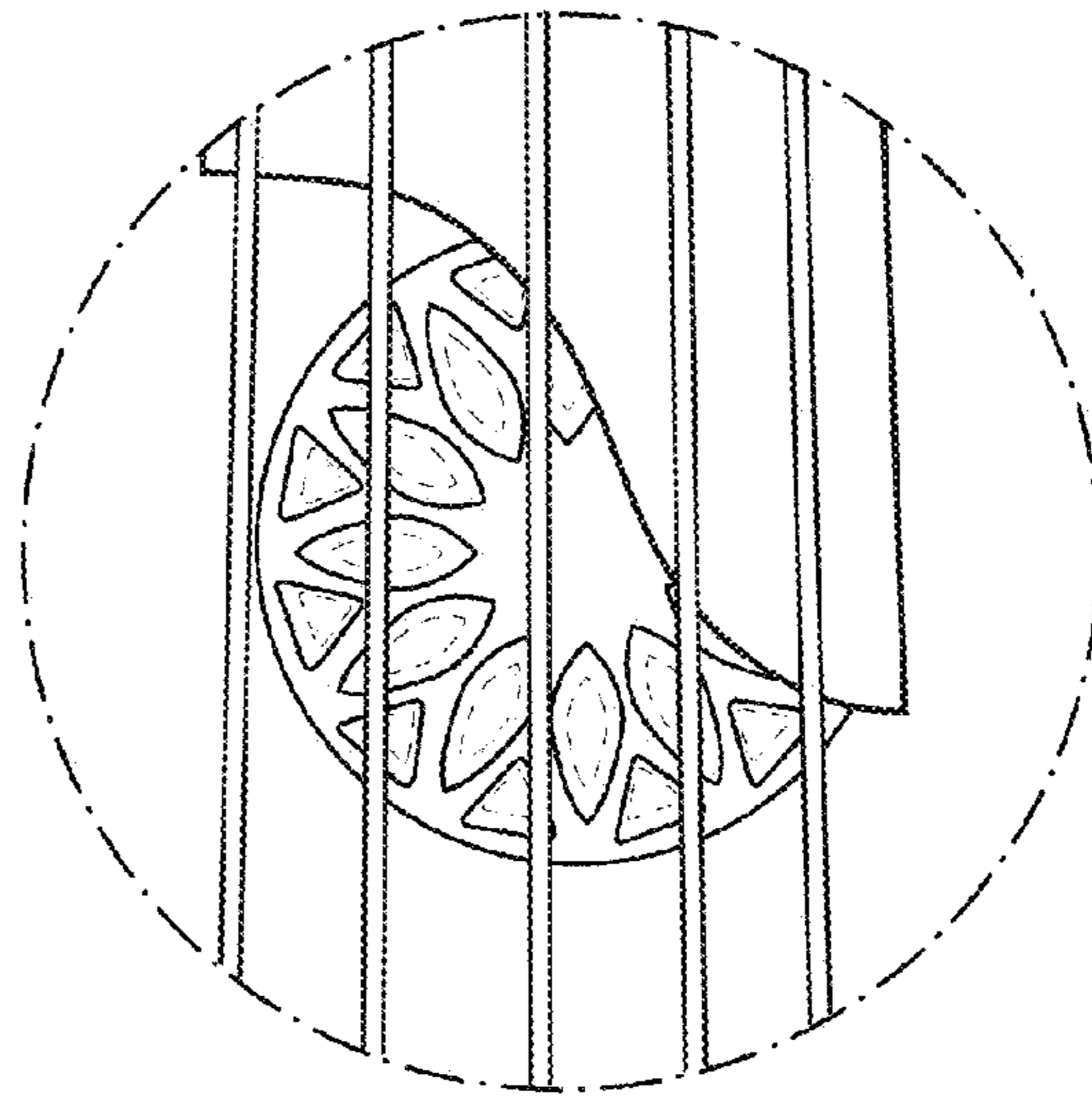
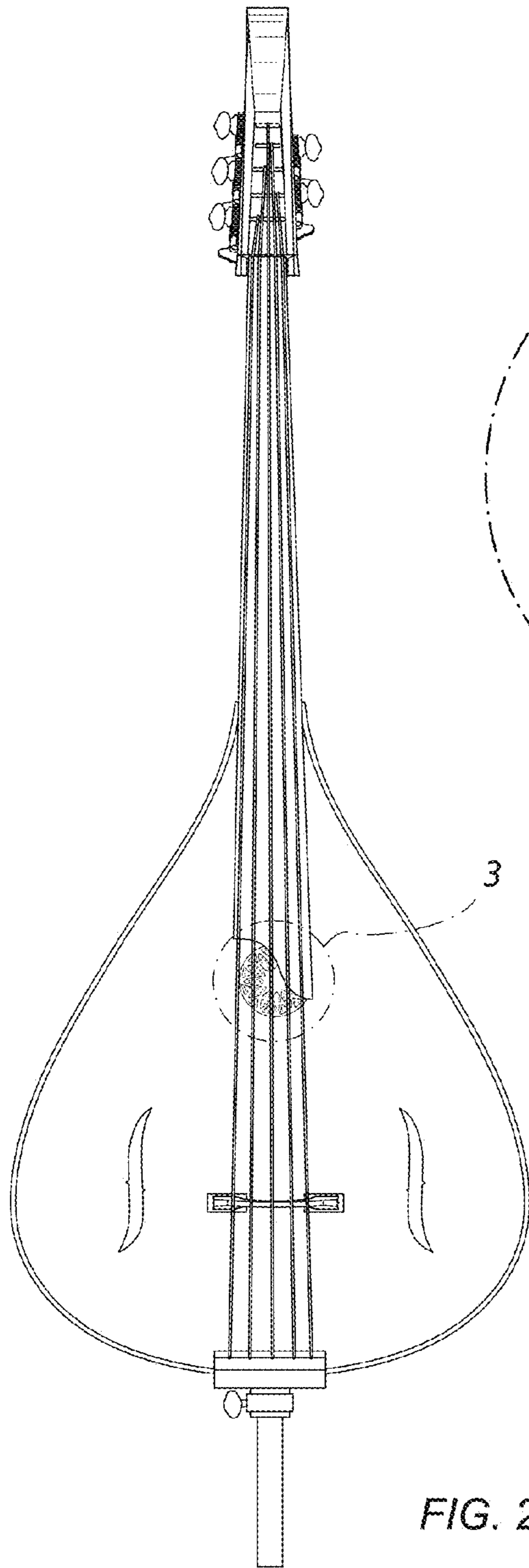

FIG. 1



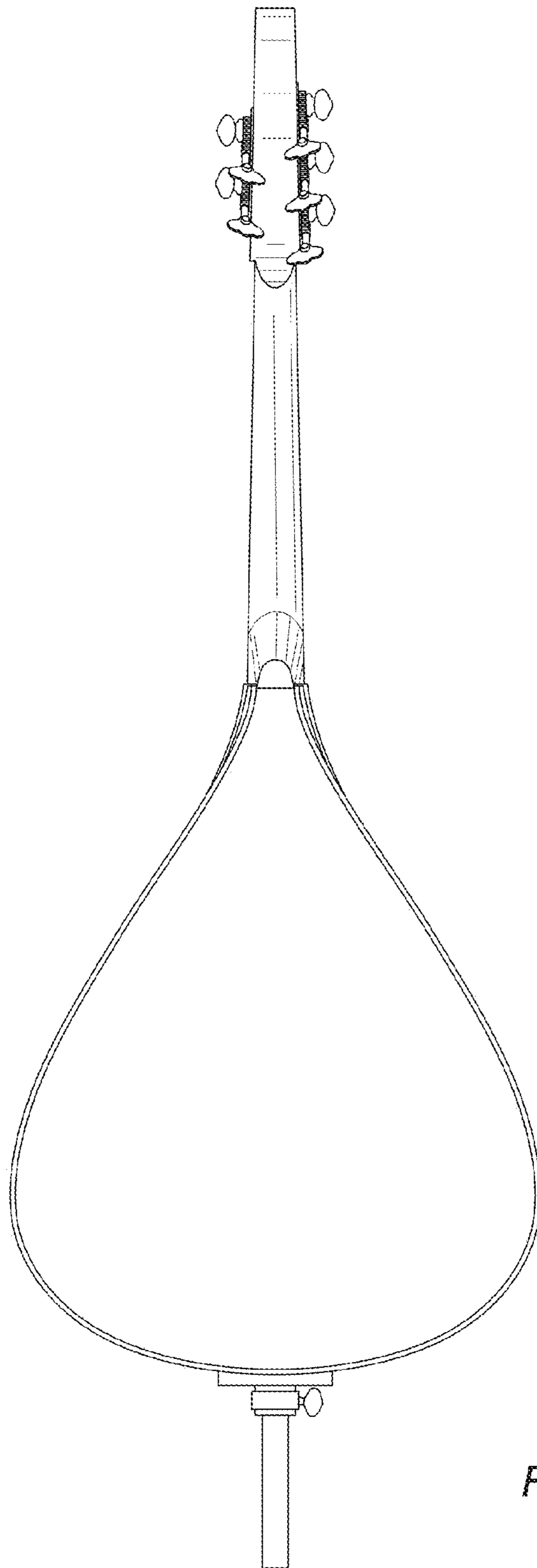
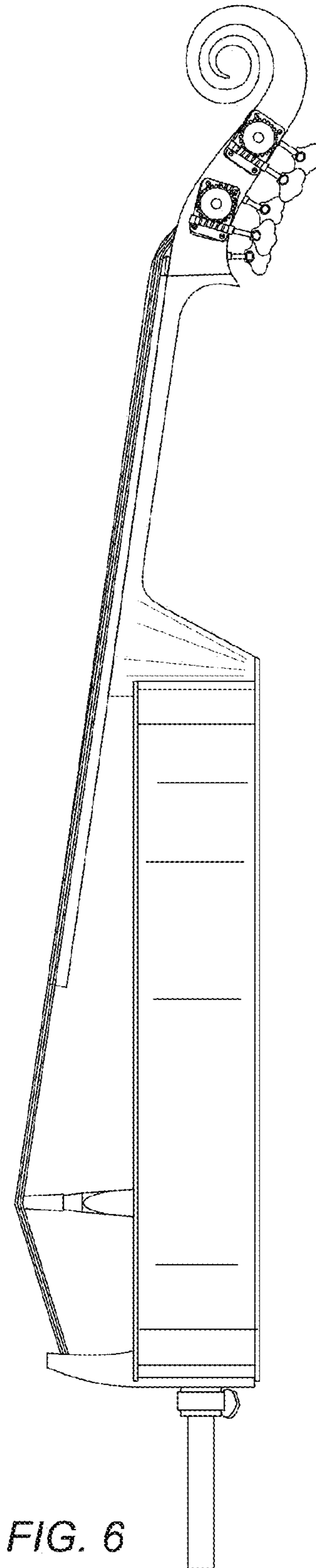
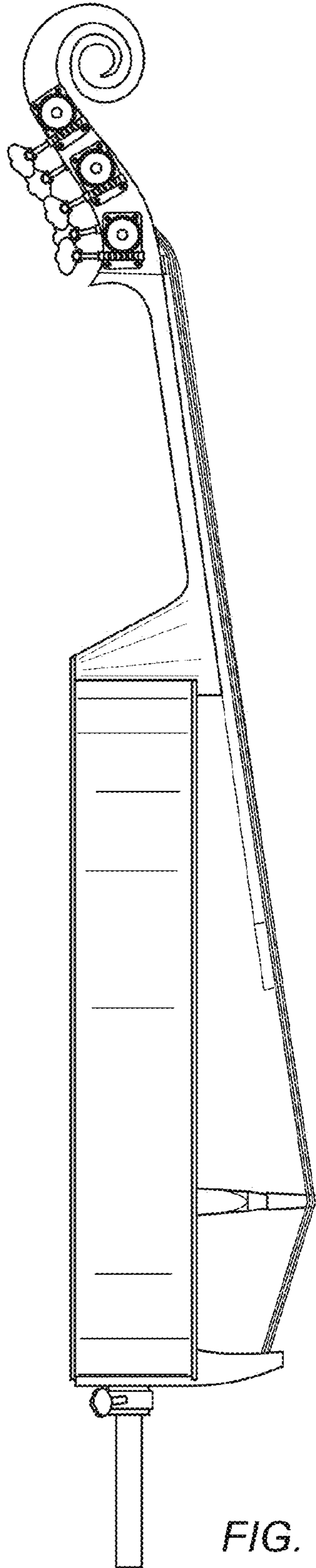

FIG. 4



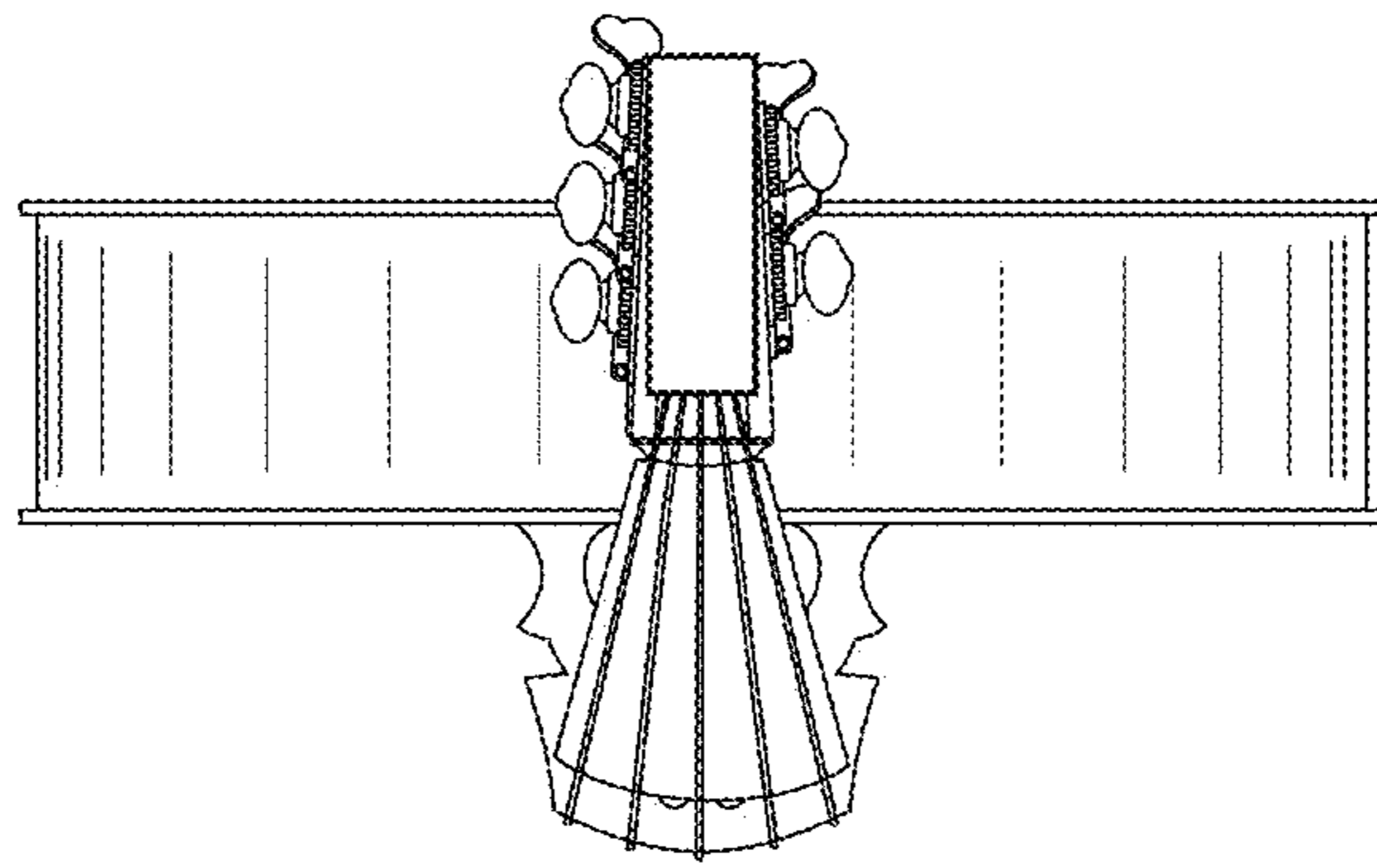

FIG. 7

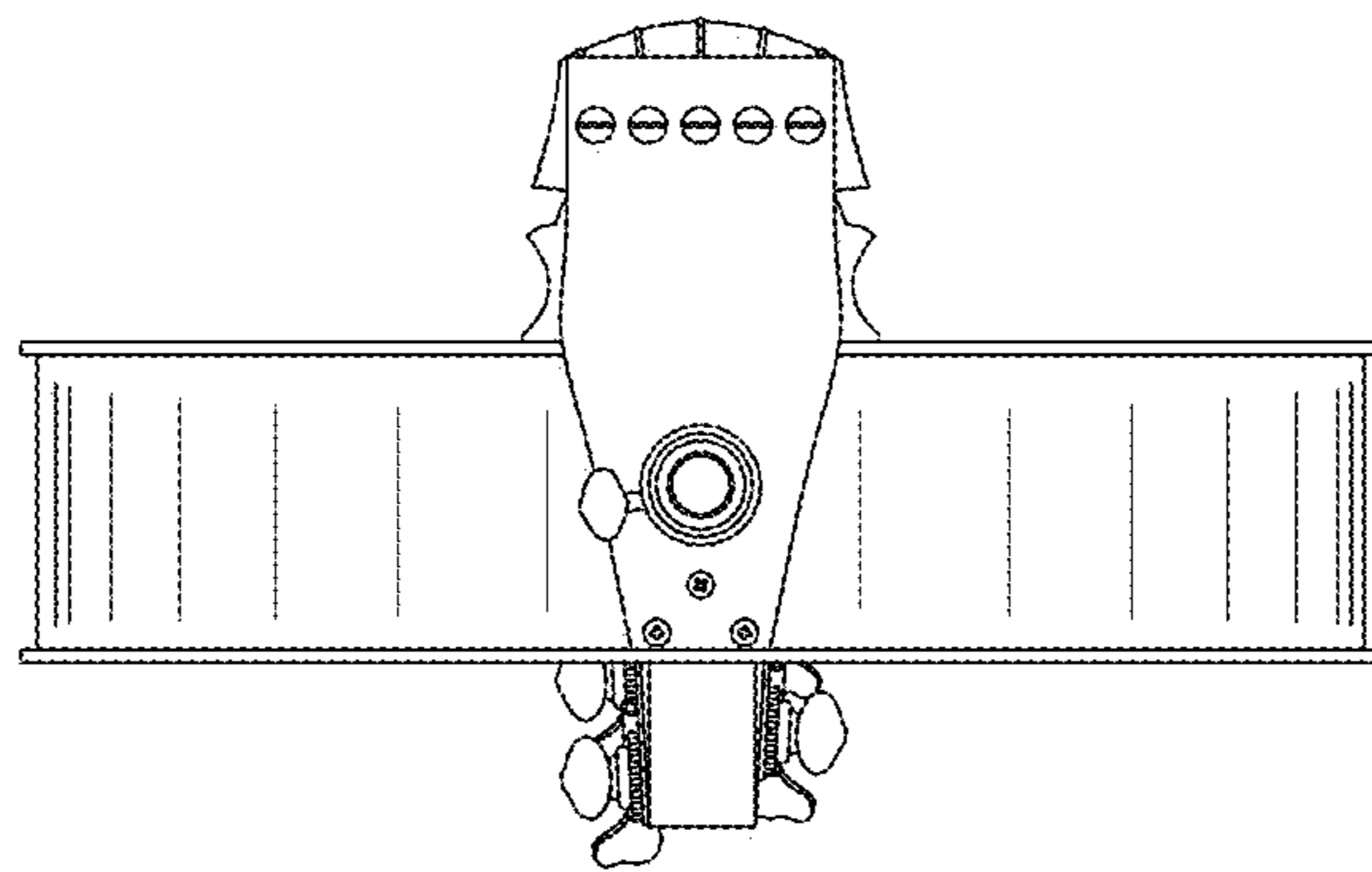

FIG. 8