



US00D743868S

(12) **United States Design Patent**
Cummings et al.

(10) **Patent No.:** **US D743,868 S**

(45) **Date of Patent:** **** Nov. 24, 2015**

(54) **VERTICAL TAKEOFF AND LANDING AIRPLANE**

(71) Applicants: **Darold B. Cummings**, Coeur d'Alene, ID (US); **David W. Hall**, Morro Bay, CA (US)

(72) Inventors: **Darold B. Cummings**, Coeur d'Alene, ID (US); **David W. Hall**, Morro Bay, CA (US)

(**) Term: **14 Years**

(21) Appl. No.: **29/495,078**

(22) Filed: **Jun. 26, 2014**

(51) **LOC (10) Cl.** **12-07**

(52) **U.S. Cl.**
USPC **D12/328**

(58) **Field of Classification Search**
USPC D12/319, 322, 323, 326, 327, 328, 329, D12/330, 339, 341, 342, 343, 344, 345; D21/436, 438, 439, 440, 441, 446, 447, D21/448, 449, 450, 453
CPC B64C 39/00; B64C 30/00; B64C 29/00
See application file for complete search history.

(56) **References Cited**

U.S. PATENT DOCUMENTS

D102,870 S *	1/1937	Brethen	D21/450
D112,834 S *	1/1939	De Seversky	D12/324
D119,714 S *	3/1940	Hibbard	D12/335
2,460,804 A *	2/1949	Brentnall	244/13
D239,522 S *	4/1976	Wheatley	D12/335
5,352,090 A *	10/1994	Churchill et al.	416/61
D543,248 S *	5/2007	Winston	D21/450

D621,332 S *	8/2010	Cazals et al.	D12/345
8,544,787 B2 *	10/2013	Lee et al.	244/7 R
D710,782 S *	8/2014	Cummings	D12/326
2010/0243821 A1 *	9/2010	Lim	244/7 A

* cited by examiner

Primary Examiner — Robert M Spear

Assistant Examiner — Marissa J Cash

(74) *Attorney, Agent, or Firm* — Law Offices of Morland C. Fischer

(57) **CLAIM**

The ornamental design for a vertical takeoff and landing airplane, as shown and described.

DESCRIPTION

FIG. 1 is a perspective view illustrating the top, right side and front a vertical takeoff and landing airplane which forms our new design, wherein the wings, propellers and tail thereof are shown in a horizontal orientation, the broken line representations of wheels and propeller blades in this and other figures showing environmental structure and forming no part of the claimed design;

FIG. 2 is a top plan view thereof;

FIG. 3 is a front elevational view thereof;

FIG. 4 is a right side elevational view thereof;

FIG. 5 is a left side elevational view thereof;

FIG. 6 is a rear elevational view thereof;

FIG. 7 is a bottom plan view thereof; and,

FIG. 8 is a perspective view illustrating the top, right side and front thereof with the wings, propellers and tail shown in a vertical orientation.

1 Claim, 4 Drawing Sheets

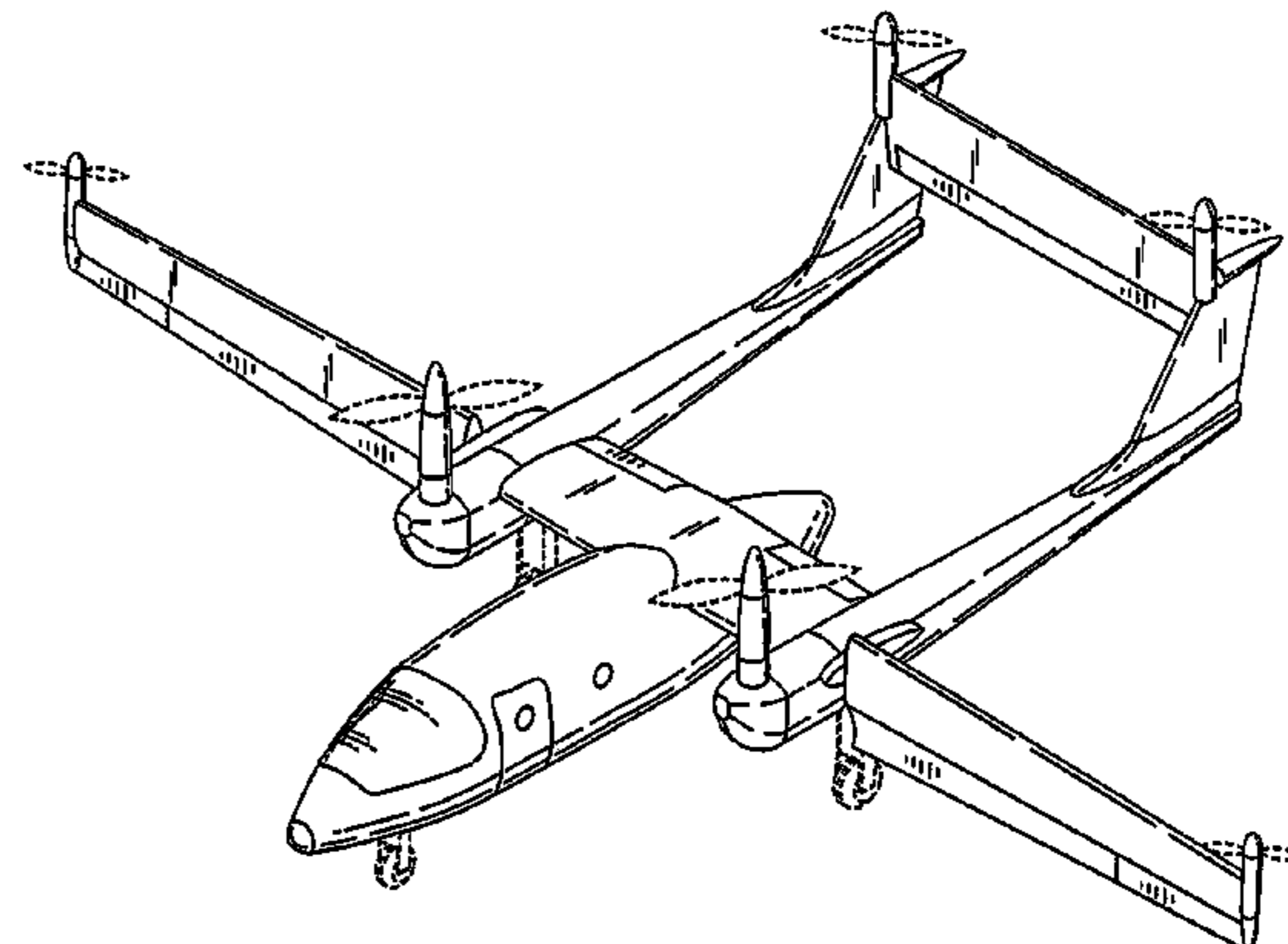
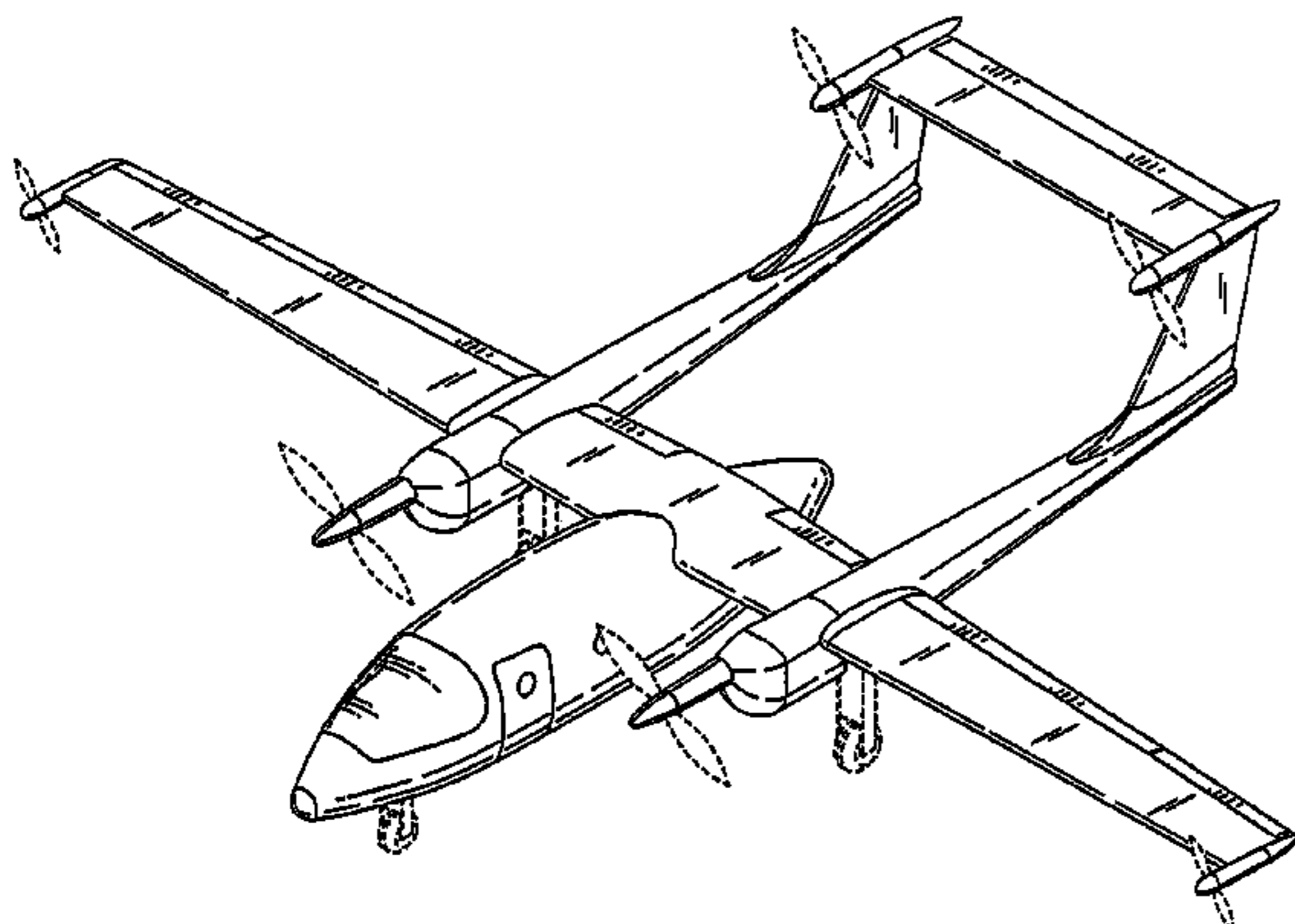

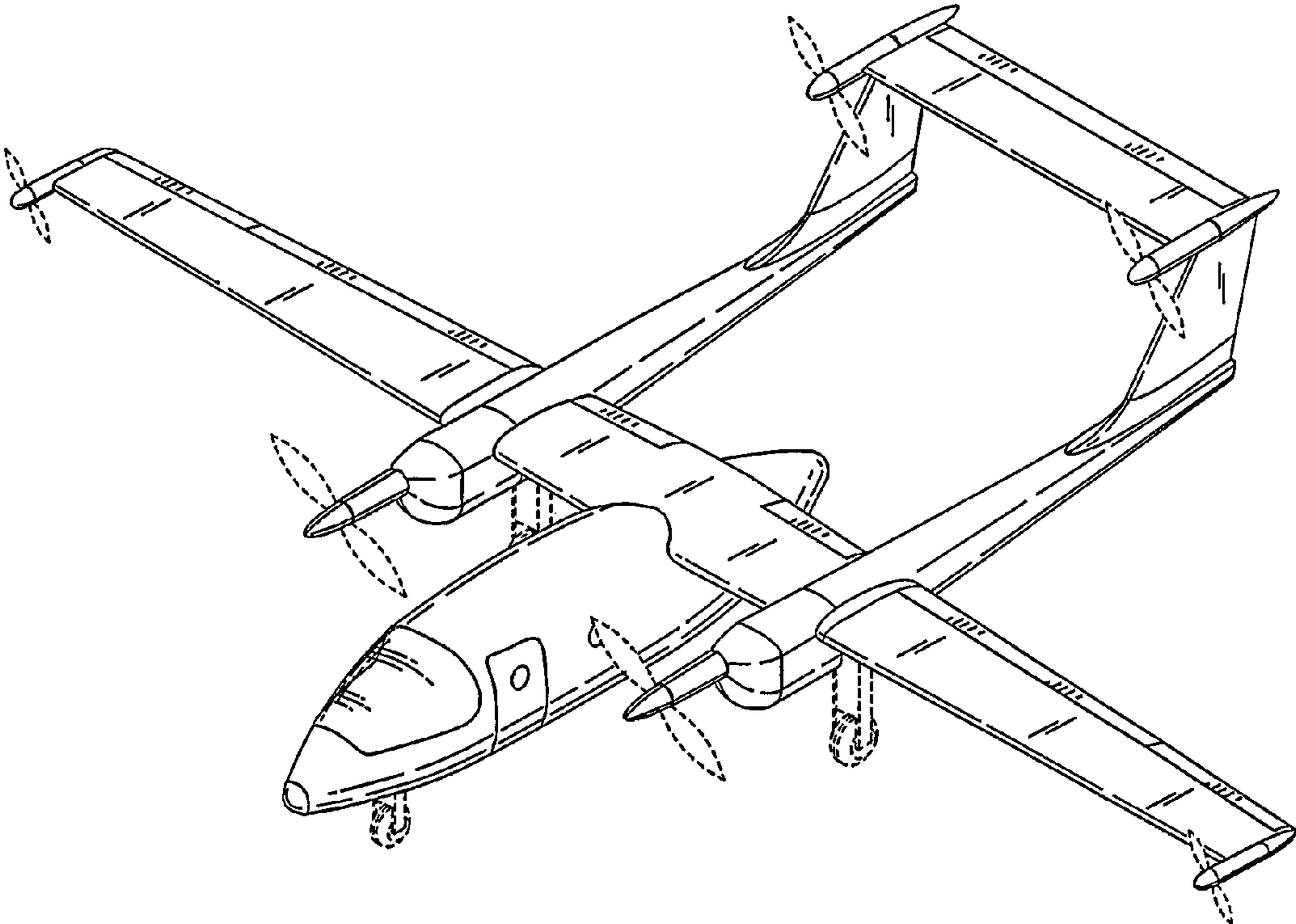

Fig. 1

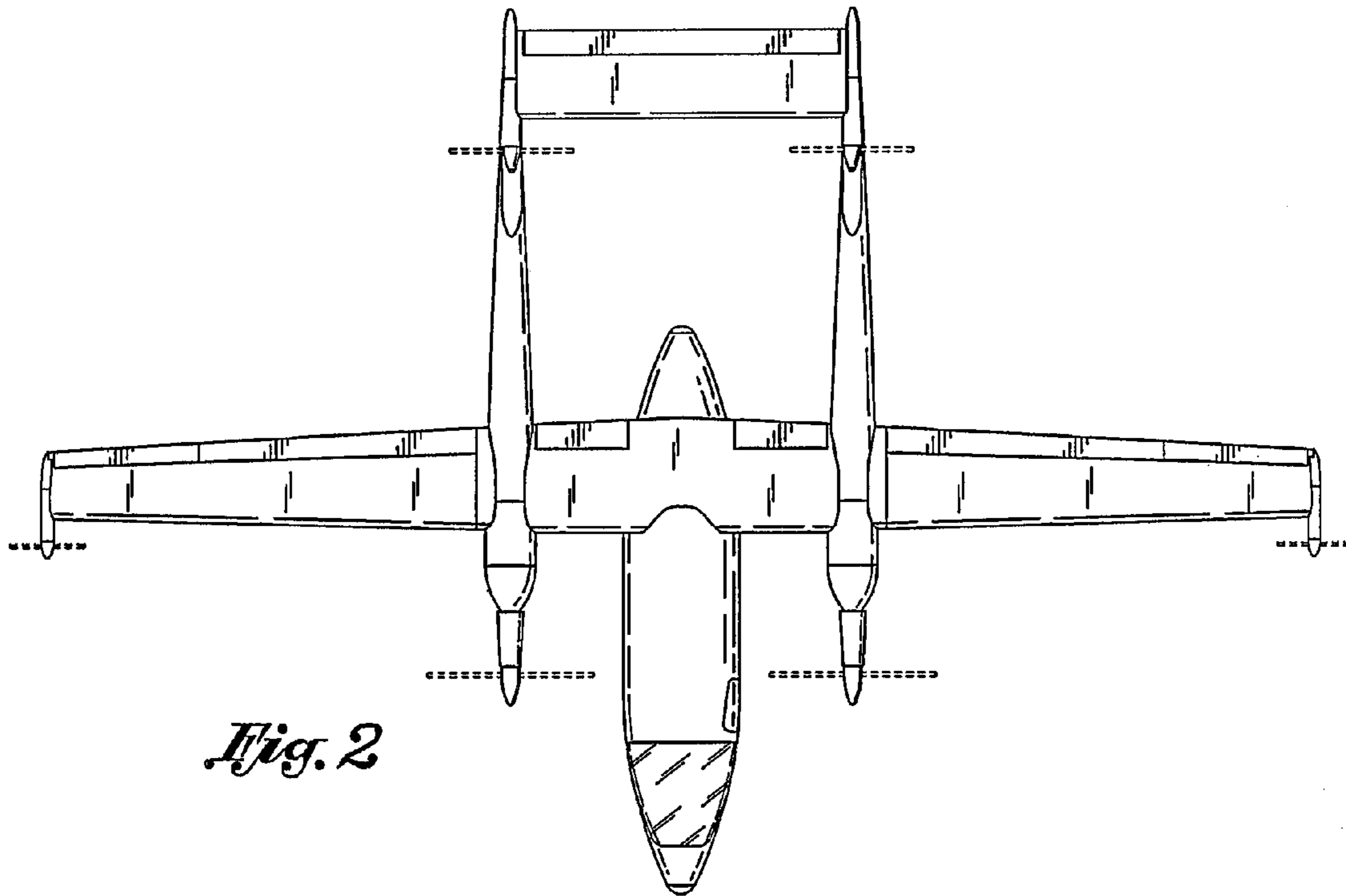

Fig. 2

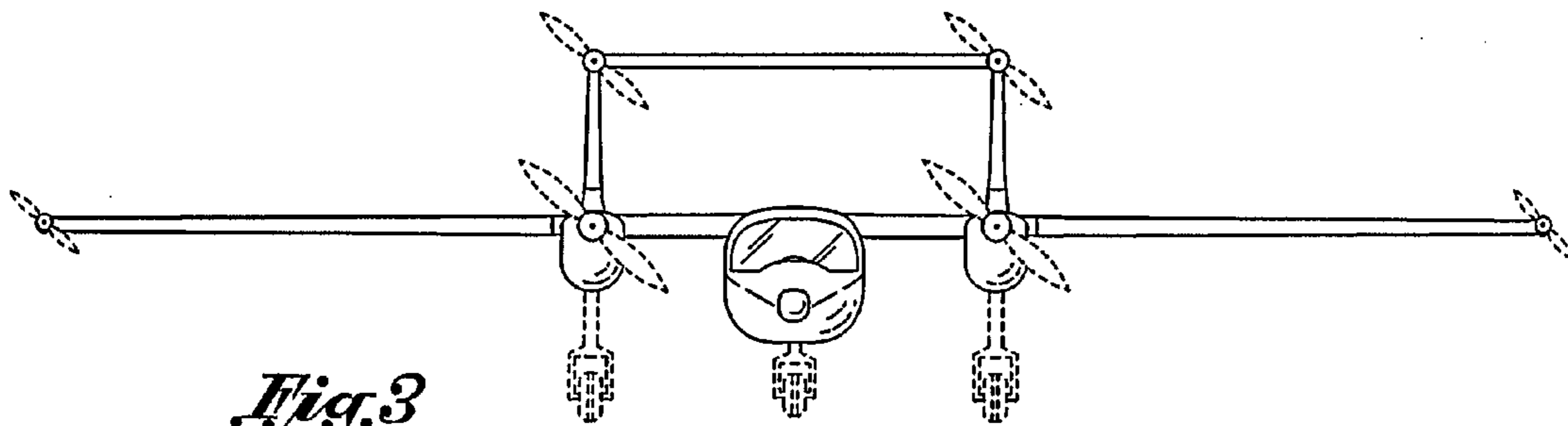

Fig. 3

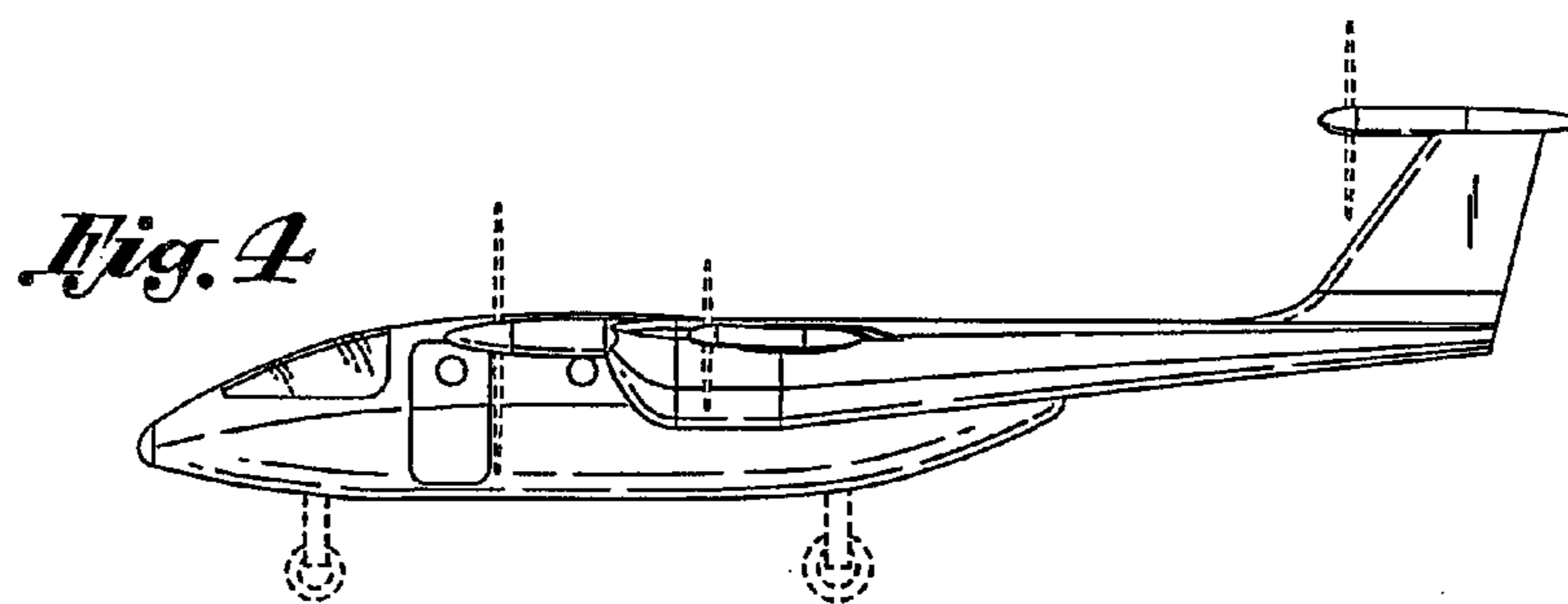

Fig. 4

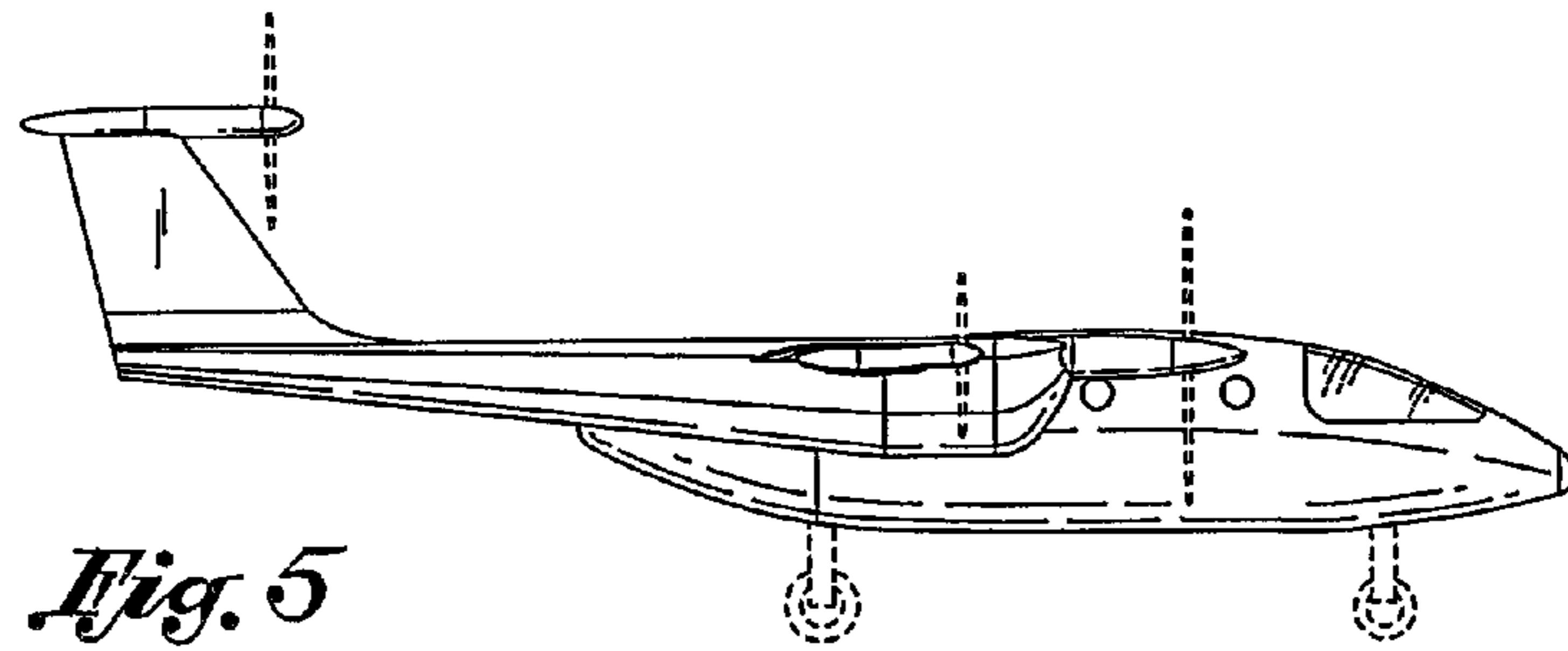

Fig. 5

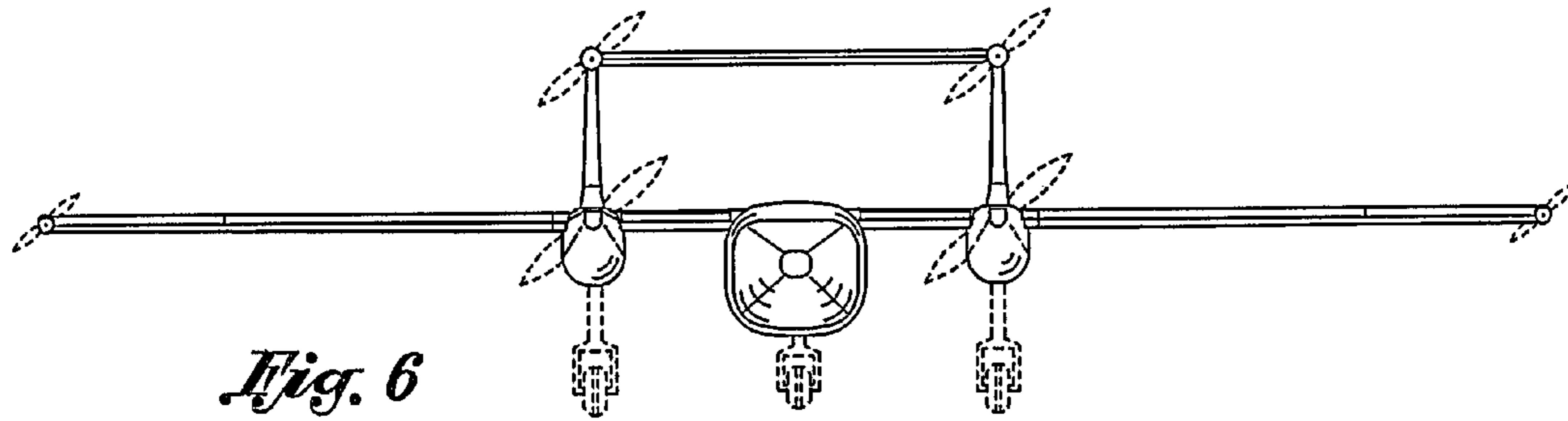

Fig. 6

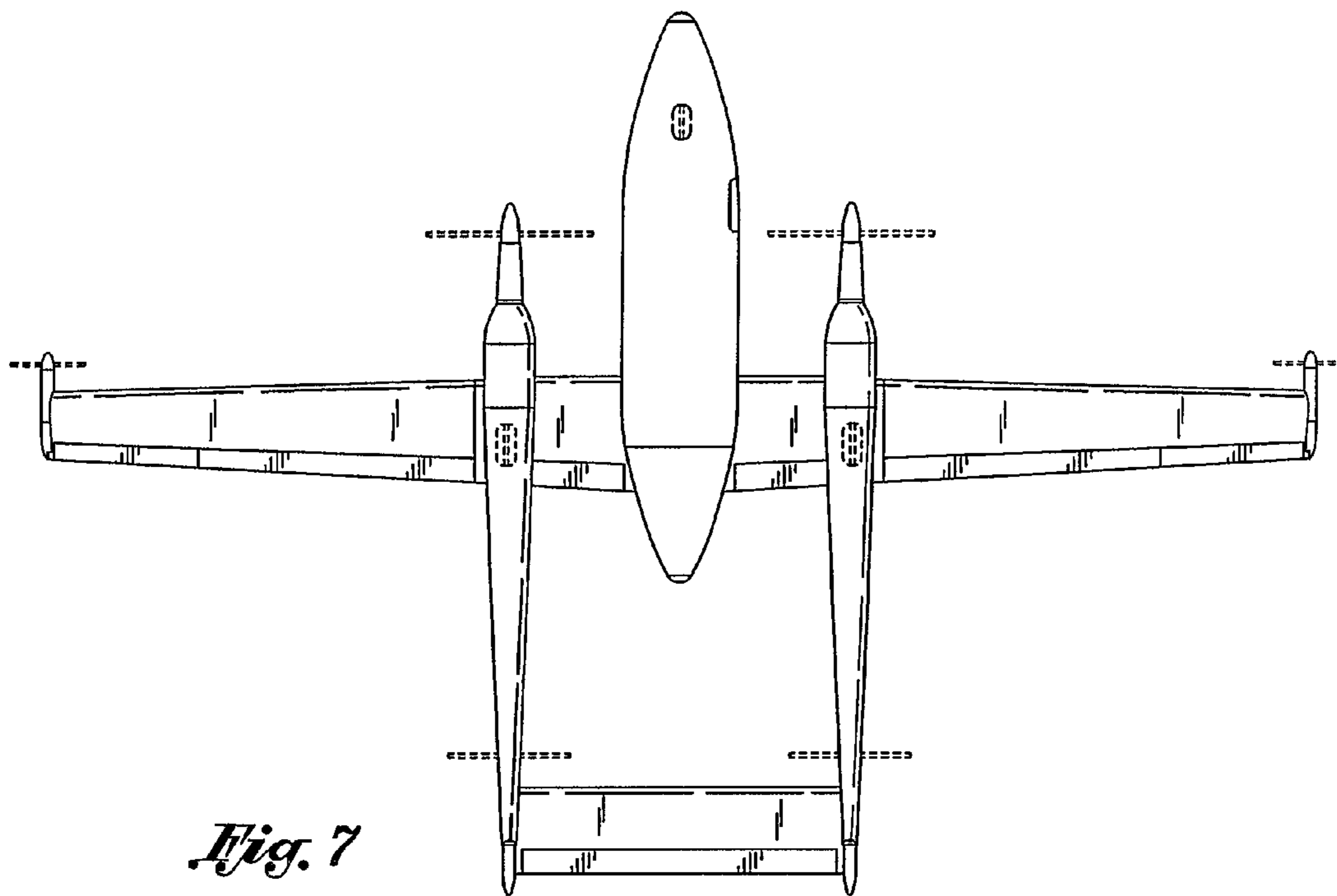

Fig. 7

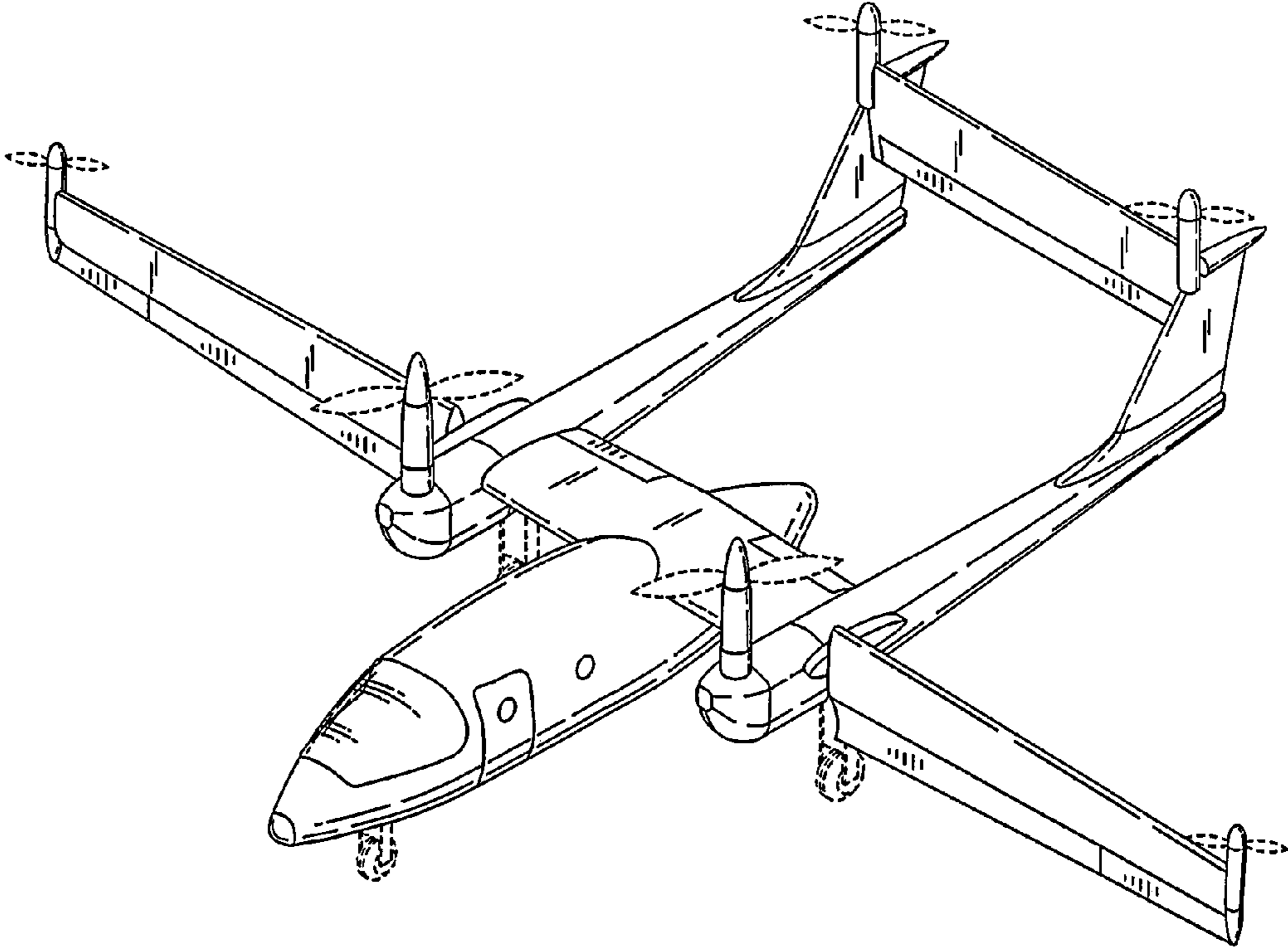

Fig. 8