



US00D743803S

(12) **United States Design Patent**
Brandenburg

(10) **Patent No.:** **US D743,803 S**

(45) **Date of Patent:** **** Nov. 24, 2015**

(54) **AIR FRESHENER CONTAINER**

(71) Applicant: **Brandywine Product Group International, Inc.**, Wilmington, DE (US)

(72) Inventor: **Kyle Brandenburg**, Middletown, DE (US)

(73) Assignee: **Brandywine Product Group International, Inc.**, Wilmington, DE (US)

(**) Term: **14 Years**

(21) Appl. No.: **29/487,057**

(22) Filed: **Apr. 4, 2014**

(51) **LOC (10) Cl.** **09-01**

(52) **U.S. Cl.**
USPC **D9/564**

(58) **Field of Classification Search**
USPC D3/202, 203.2, 901; D4/116; D7/313, D7/401.1, 590-612, 619.1; D9/502, 504, D9/506, 519, 520, 522, 523, 526, 529, 530, D9/558, 559, 560, 563, 564, 569, 571, 574, D9/682, 686, 687, 689, 719; D19/93; D21/684; D23/211.1-211.2, 366; D24/121, 124, 197, 224; D28/4, 7, 20, D28/66, 76, 82, 83, 85, 88, 89, 91.1; D32/29.1; D34/1, 2, 11, 39; 215/62.22, 215/220, 329, 382-385, 396, 398; 239/57
CPC A61J 1/03; A61J 1/05; A47G 19/22; A47G 19/2205; A47G 19/2266; B65D 1/02; B65D 1/0223; B65D 1/08; B65D 1/10
See application file for complete search history.

(56) **References Cited**

U.S. PATENT DOCUMENTS

D318,613 S * 7/1991 Halm et al. D32/29.1
D321,129 S * 10/1991 Giuseppe D9/502

(Continued)

OTHER PUBLICATIONS

Elite Ball Wide Mouth Jars: Announced Aug. 3, 2012 [online] site visited [Jun. 23, 2015]. Available from Internet URL:<<http://www.filmorecontainer.com/elite-Ball-16oz-WM-Jars-with-Bands-Lids-P181.aspx>>.*

Primary Examiner — Thomas Johannes

Assistant Examiner — Catherine Posthauer

(74) *Attorney, Agent, or Firm* — Panitch Schwarze Belisario & Nadel LLP

(57) **CLAIM**

The ornamental design for an air freshener container, as shown and described.

DESCRIPTION

FIG. 1 is a right front perspective view of the an air freshener container;

FIG. 2 is a right bottom perspective view thereof;

FIG. 3 is a front elevation view thereof;

FIG. 4 is a right side elevation view thereof;

FIG. 5 is a rear elevation view thereof;

FIG. 6 is a left side elevation view thereof;

FIG. 7 is a top plan view thereof;

FIG. 8 is a bottom plan view thereof;

FIG. 9 is a right front perspective view of the container with the lid shown removed to illustrate details not visible in other views;

FIG. 10 is a right bottom perspective view thereof;

FIG. 11 is a front elevation view thereof;

FIG. 12 is a right side elevation view thereof;

FIG. 13 is a rear elevation view thereof;

FIG. 14 is a left side elevation view thereof;

FIG. 15 is a top plan view thereof; and,

FIG. 16 is a bottom plan view thereof.

The broken lines are shown for the purpose of illustrating unclaimed portions of the air freshener container and form no part of the claimed design.

No claim boundary lines are shown in the disclosure; the long and short regularly spaced lines are shown for the purpose of showing curvature and contour only.

1 Claim, 16 Drawing Sheets

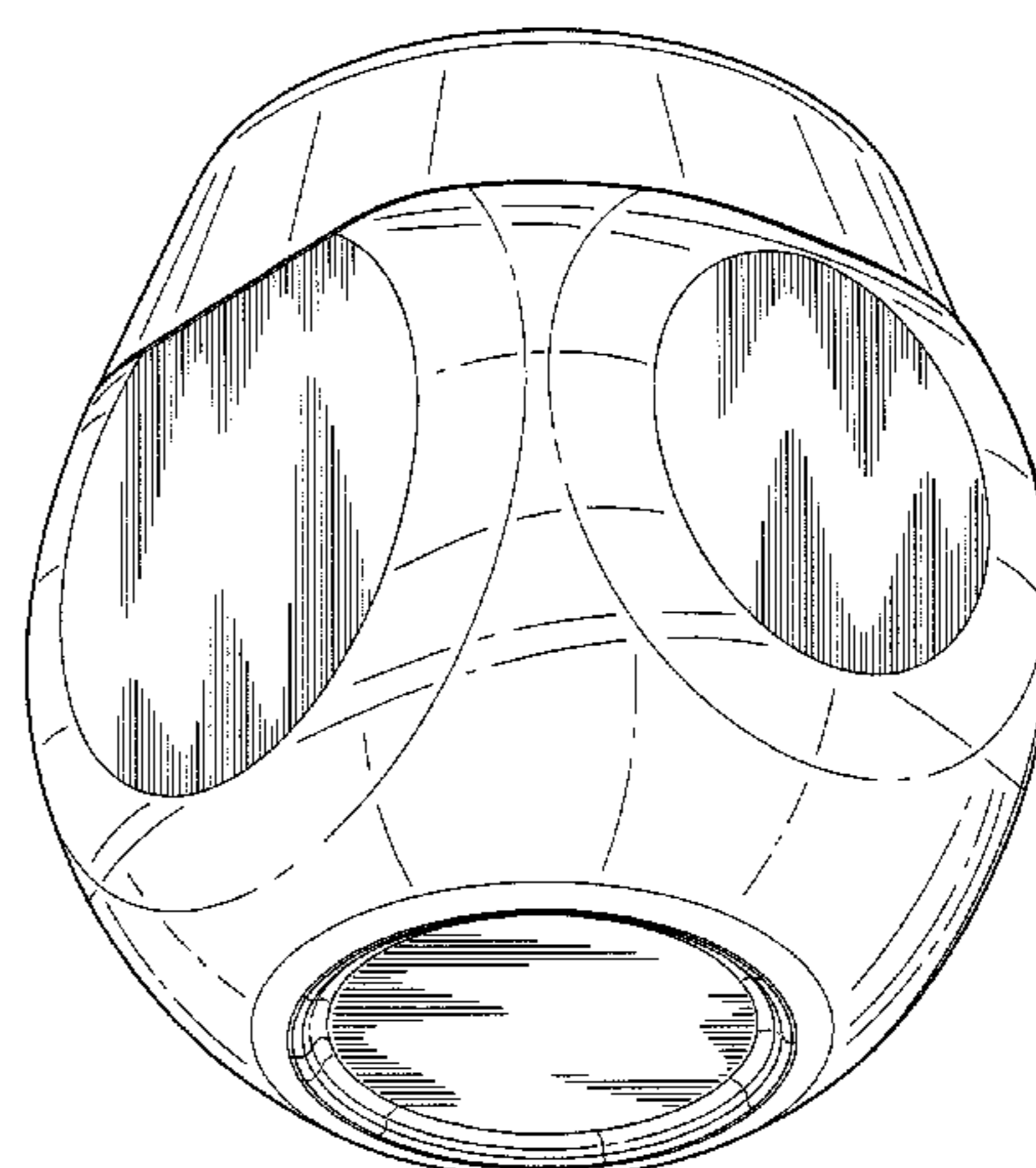
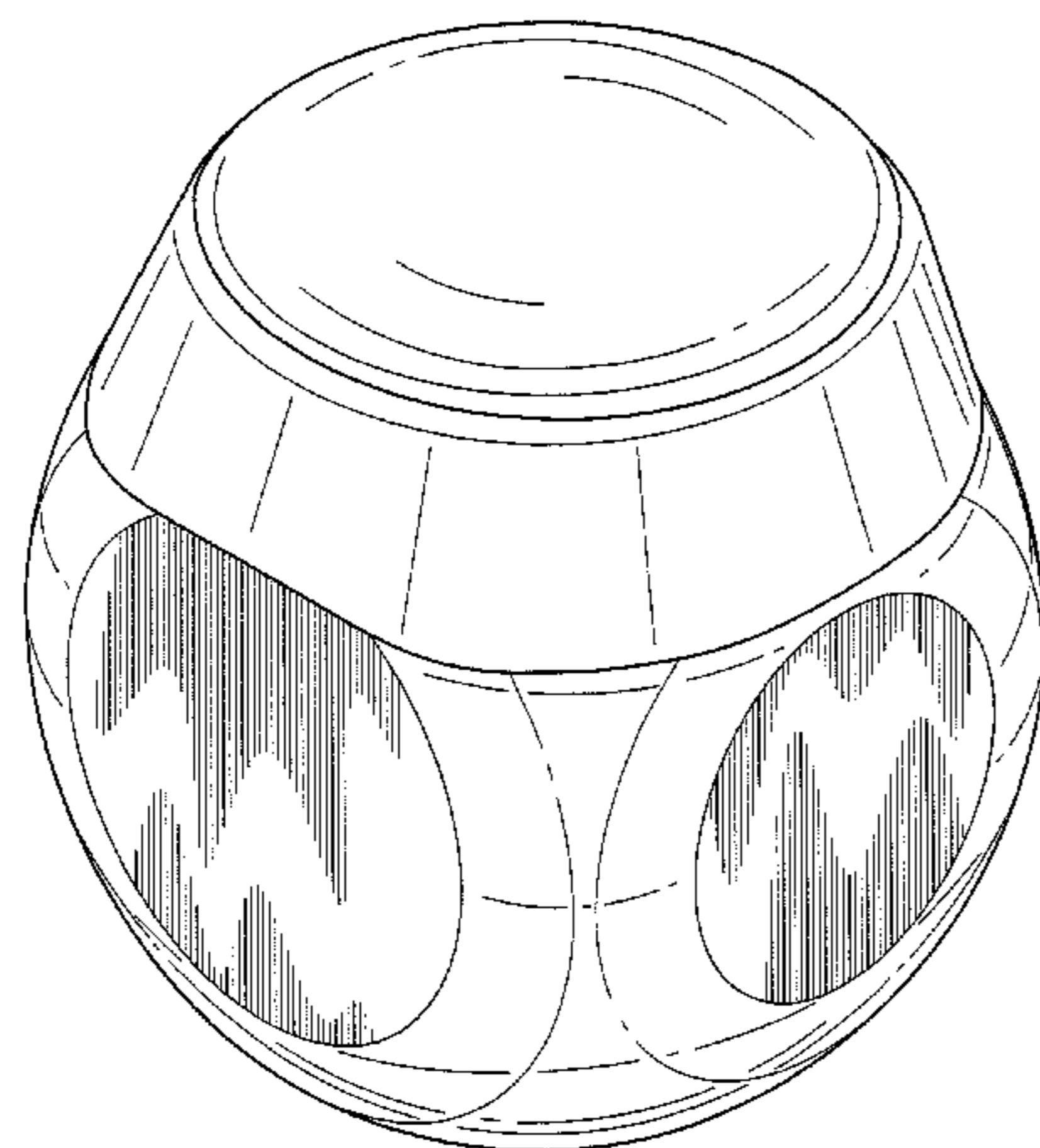

(56)

References Cited

U.S. PATENT DOCUMENTS

D321,476 S * 11/1991 Alcover D32/29.1
D582,291 S * 12/2008 de Baschmakoff D9/560
D584,154 S * 1/2009 Fitzsimmons et al. D9/526
D585,303 S * 1/2009 Fitzsimmons et al. D9/719

D603,266 S * 11/2009 Dibnah et al. D9/529
D610,009 S * 2/2010 Prufer D9/504
D708,790 S * 7/2014 Schlatter D28/89
D708,791 S * 7/2014 Schlatter D28/89
8,978,999 B2 * 3/2015 Lesniak et al. 239/57
D729,370 S * 5/2015 Chou D23/366

* cited by examiner

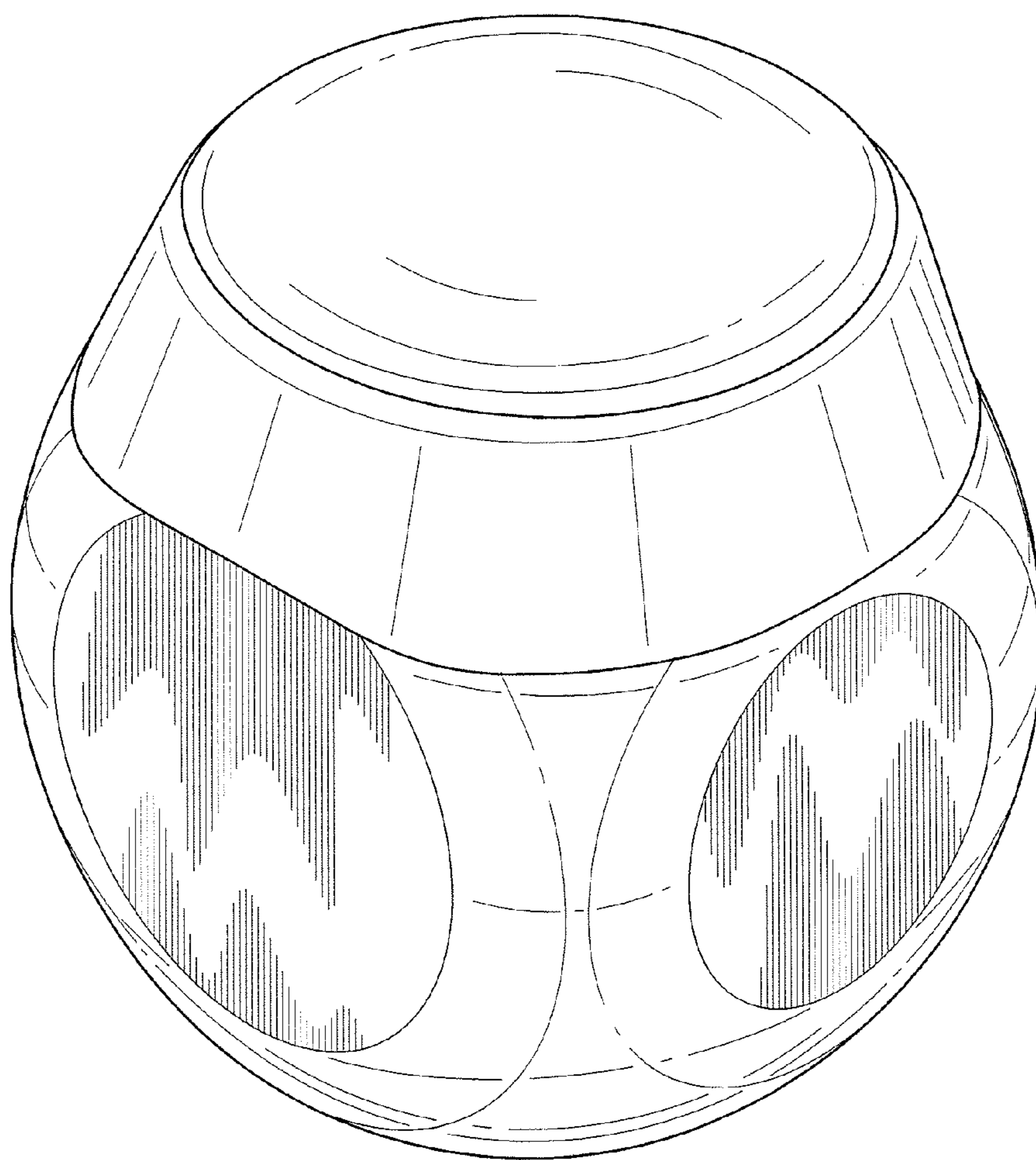

FIG. 1

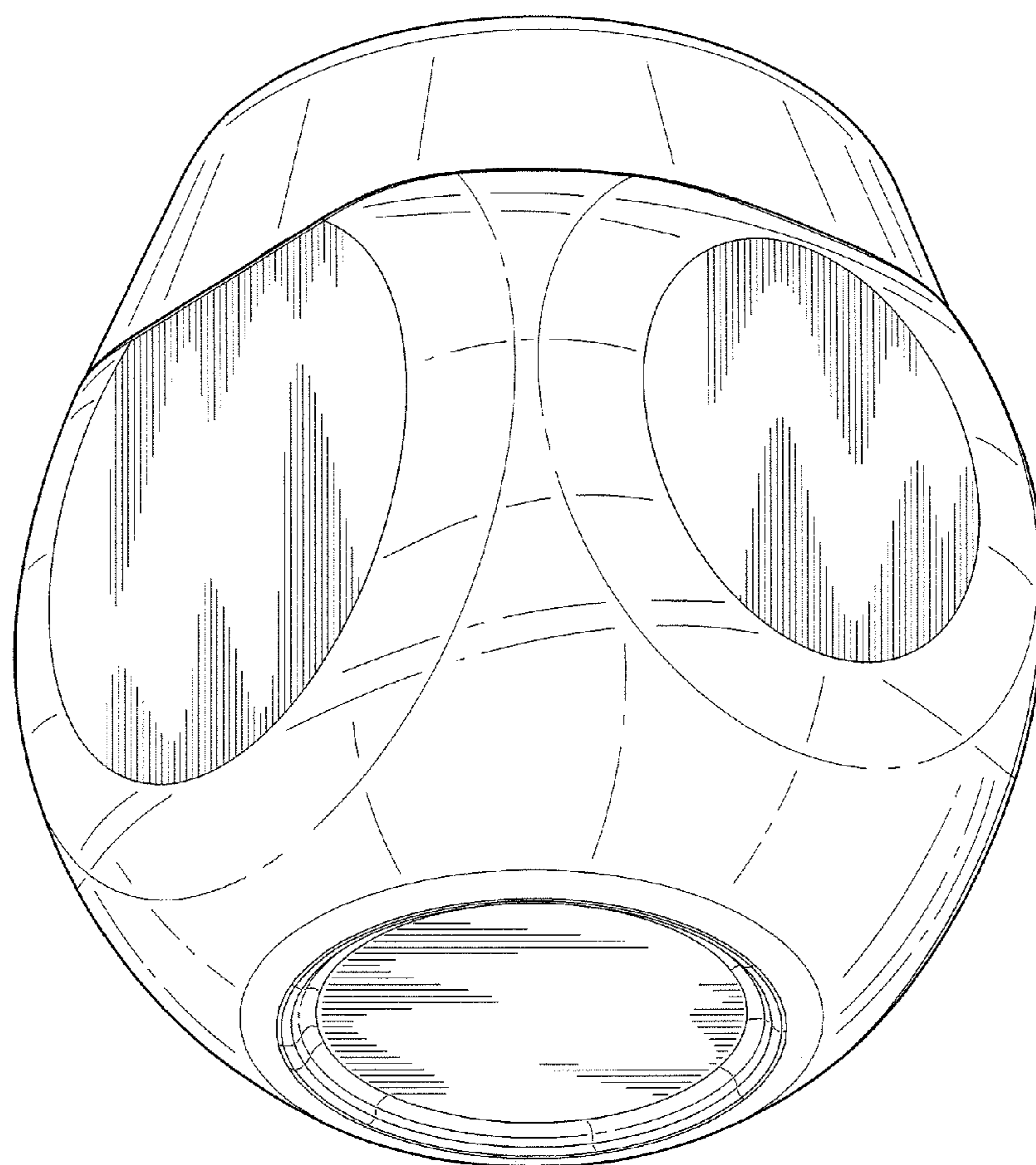

FIG. 2

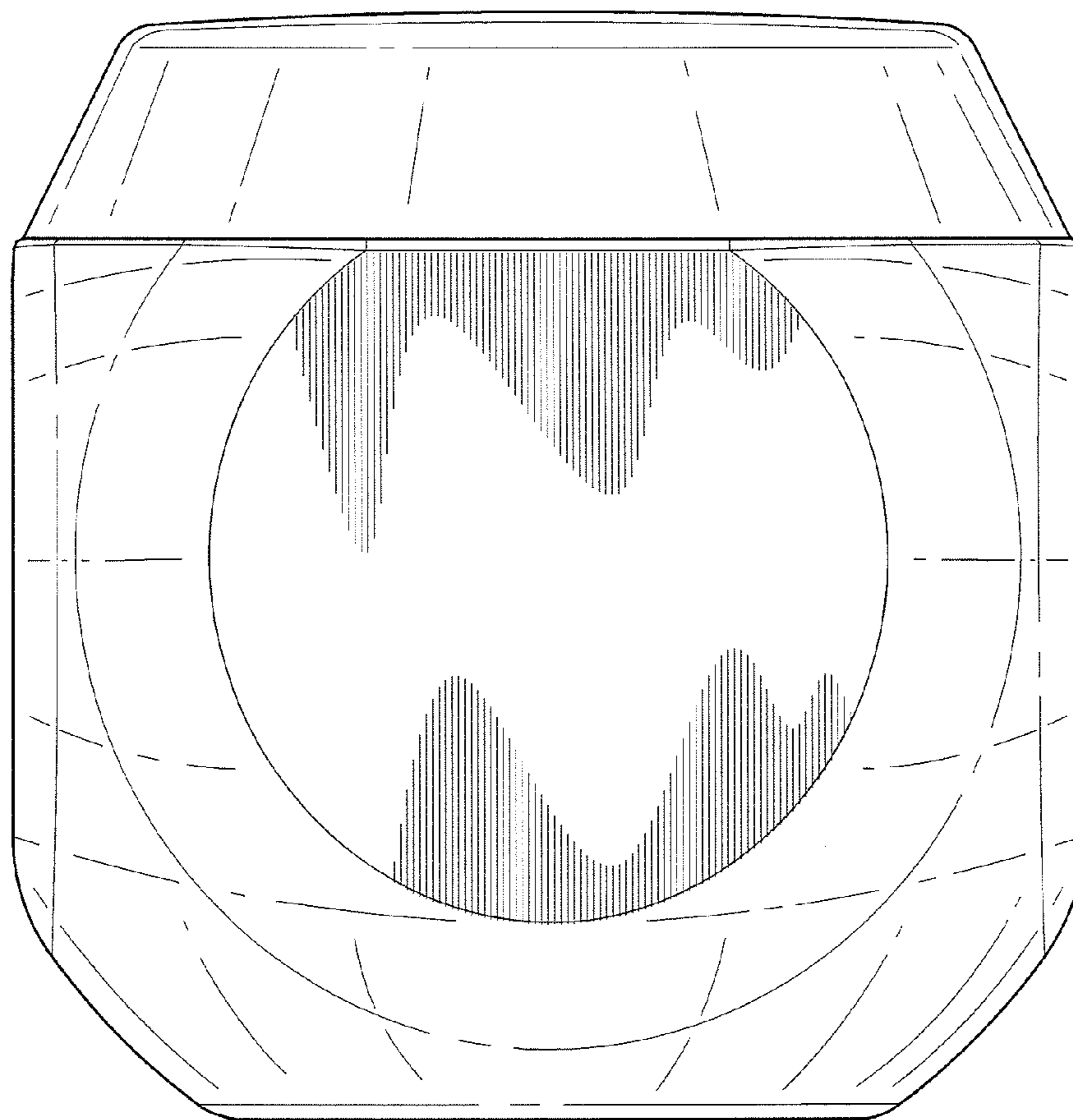

FIG. 3

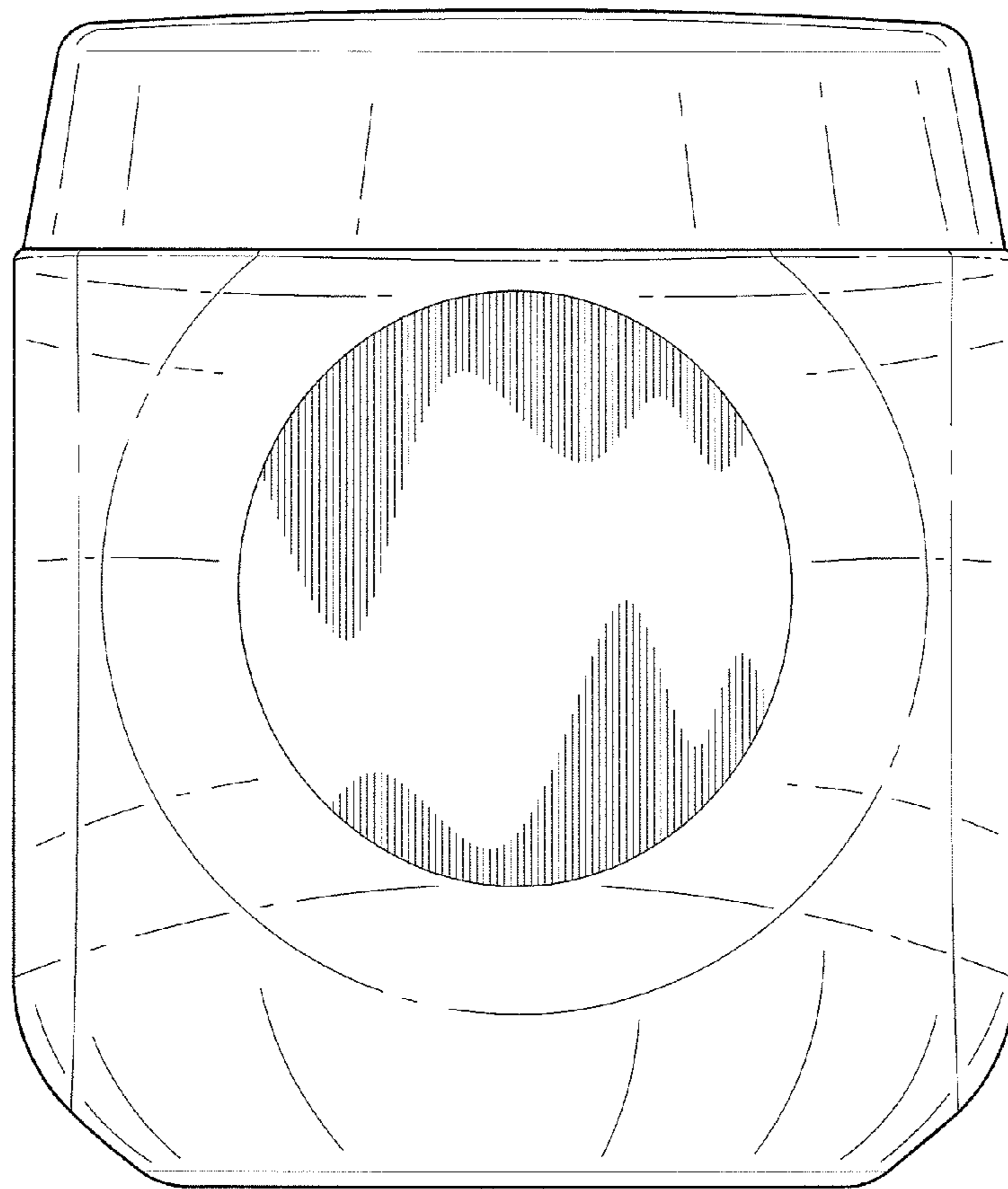

FIG. 4

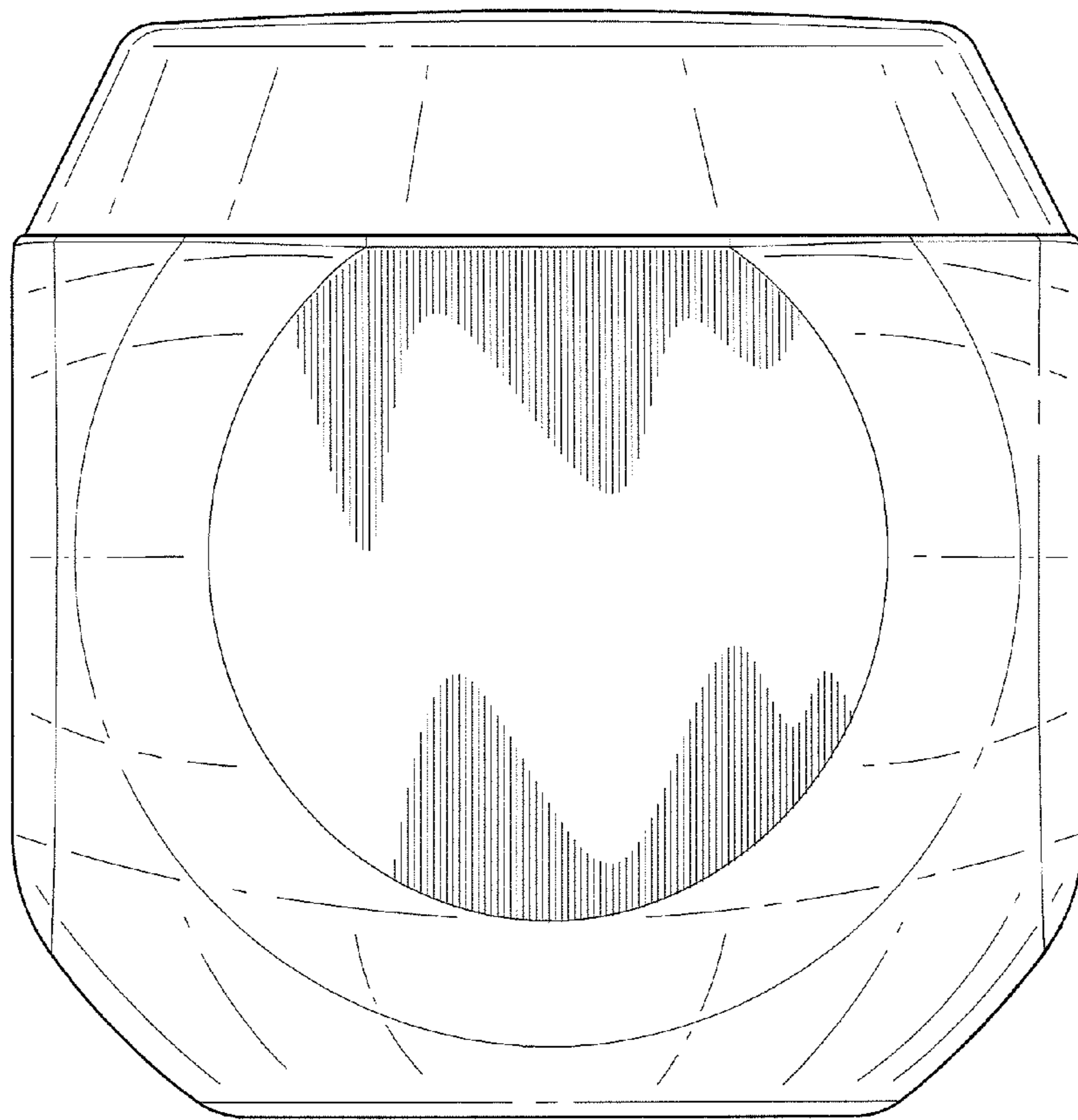

FIG. 5

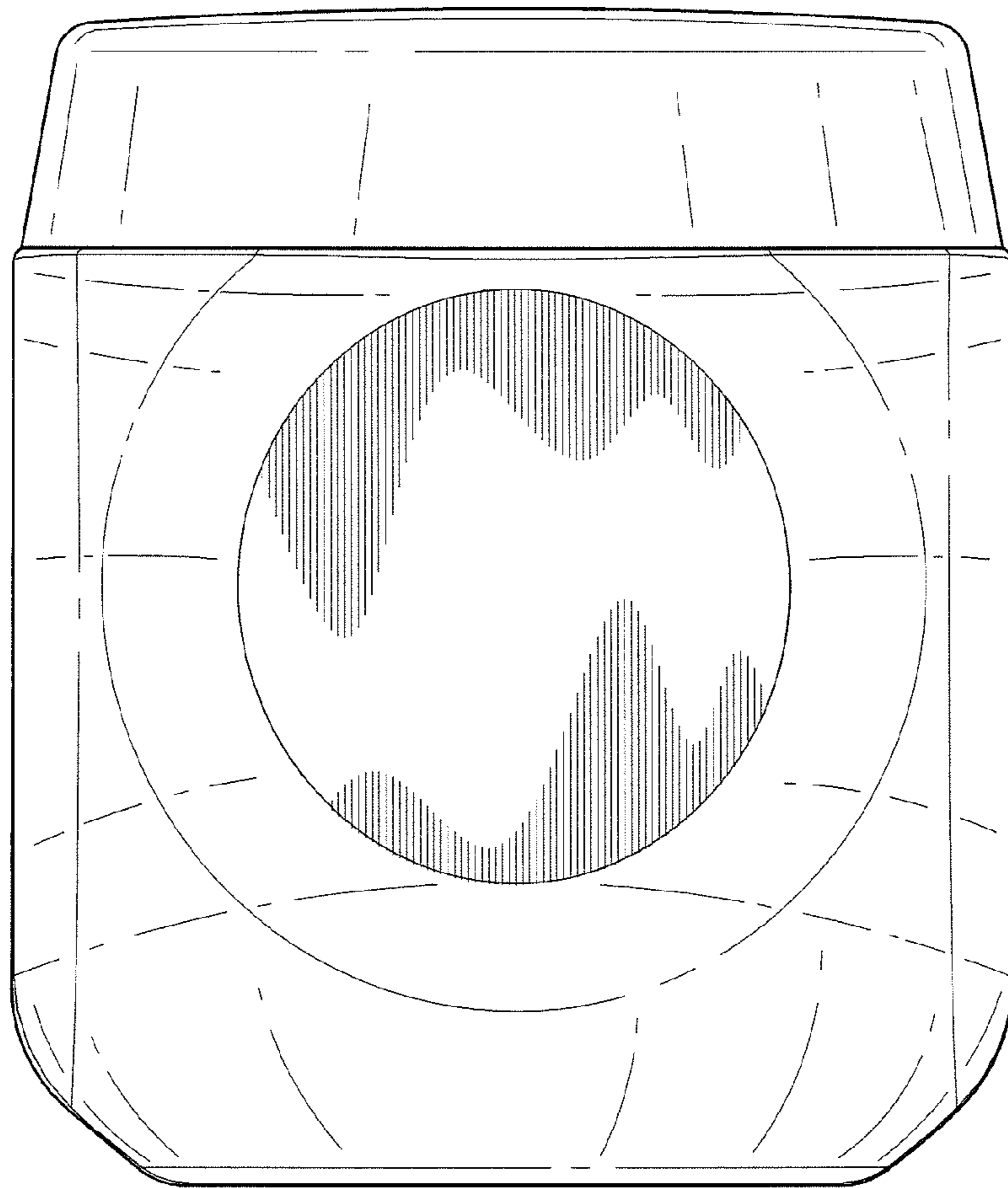

FIG. 6

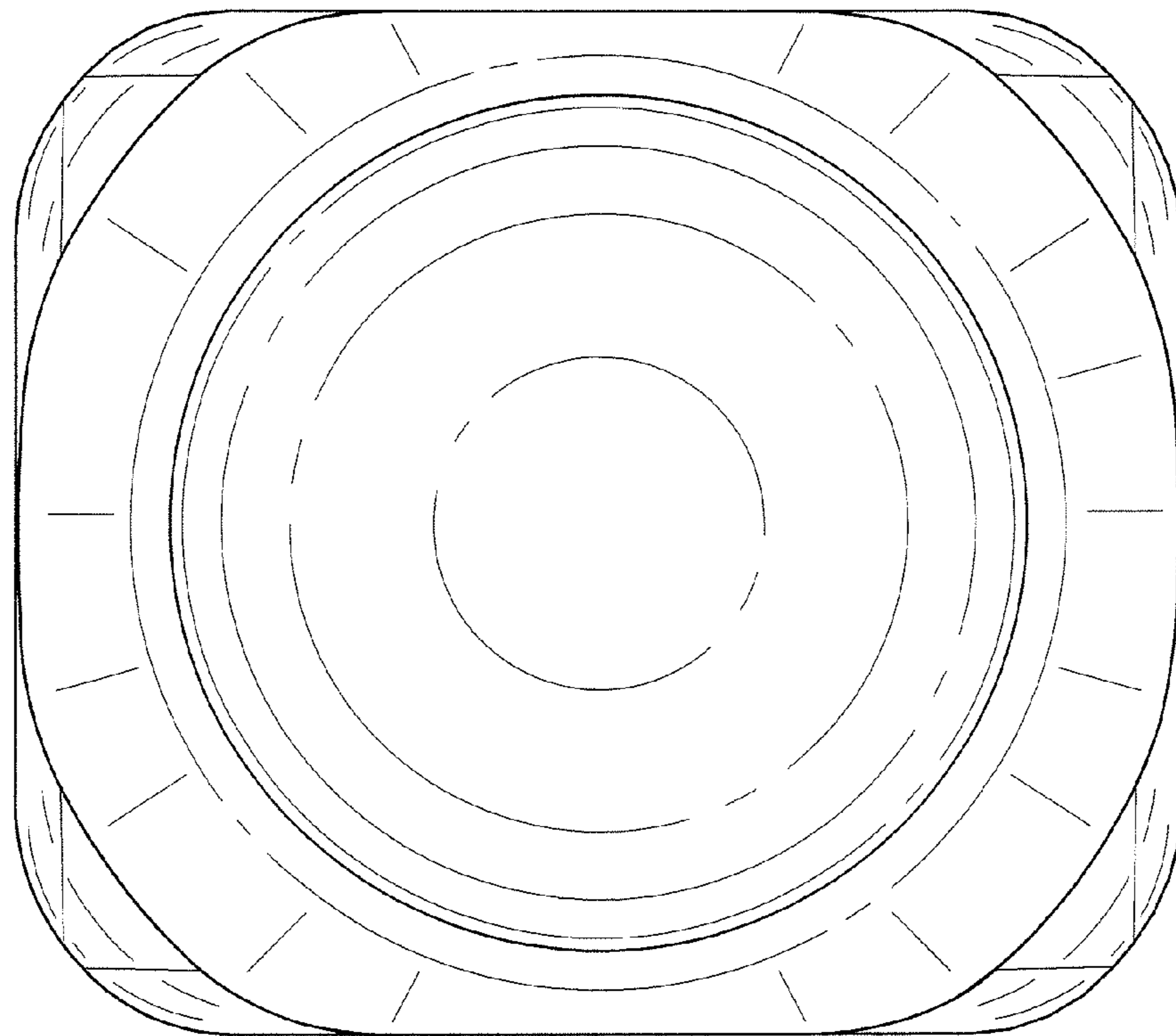

FIG. 7

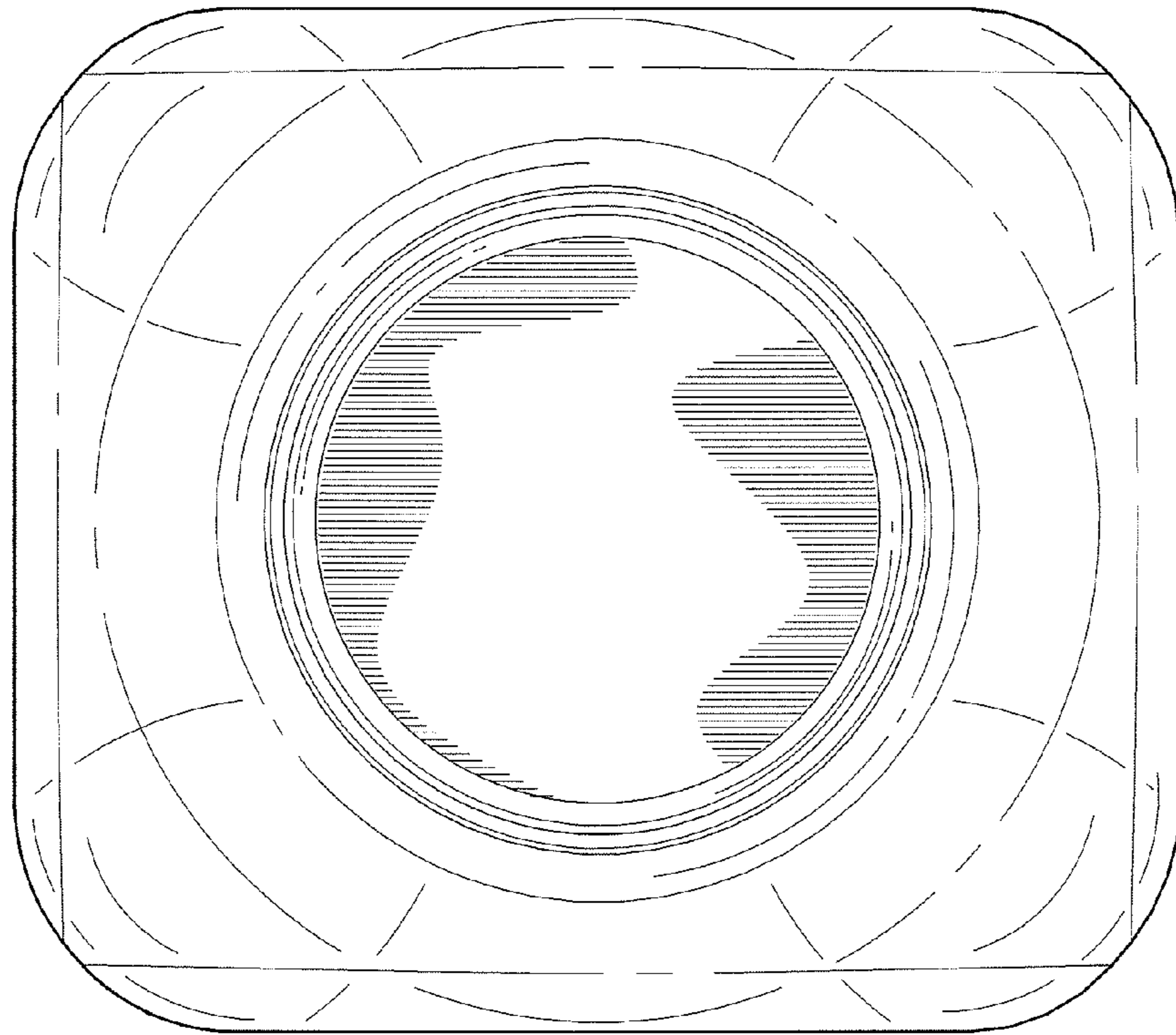

FIG. 8

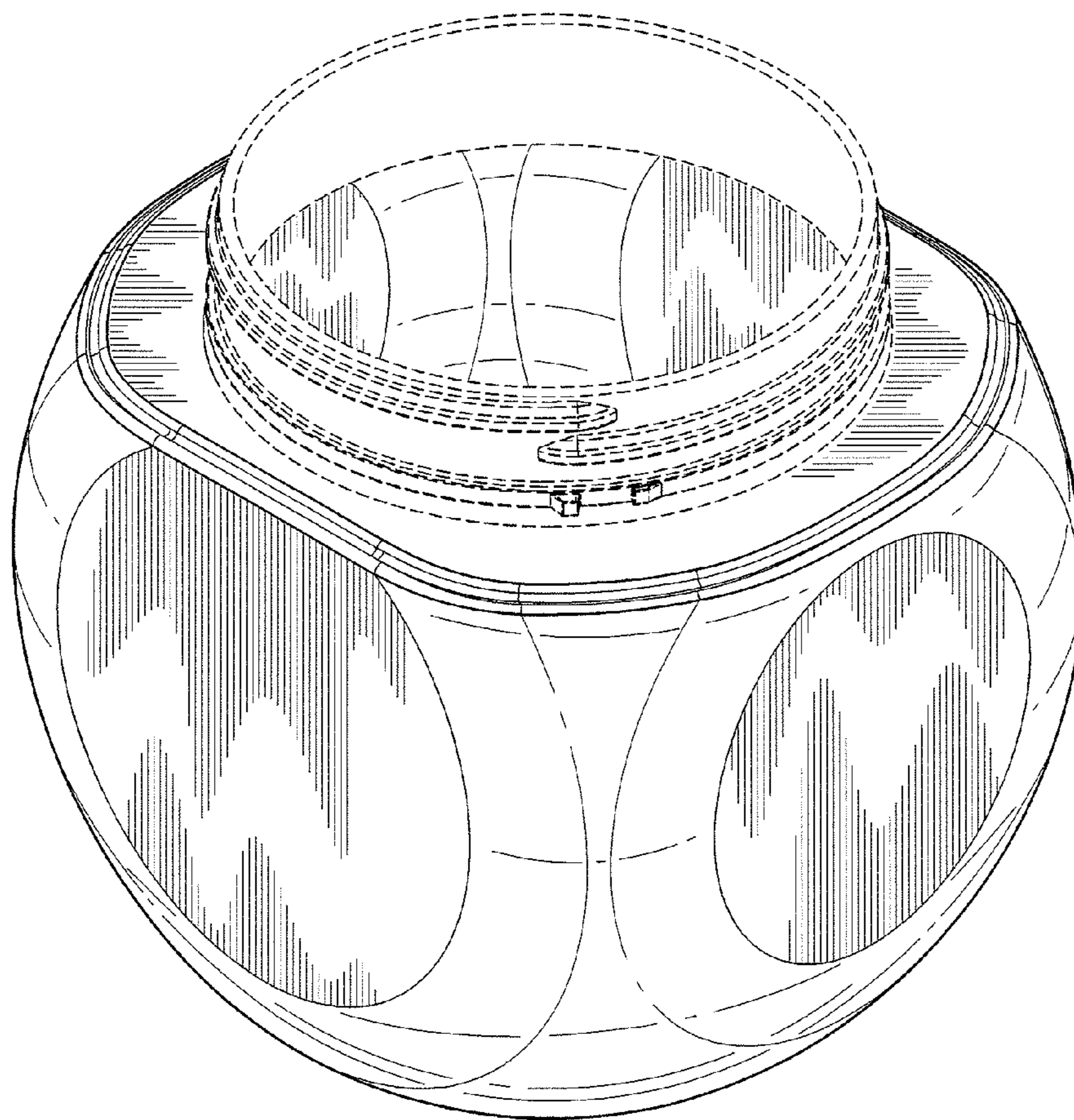

FIG. 9

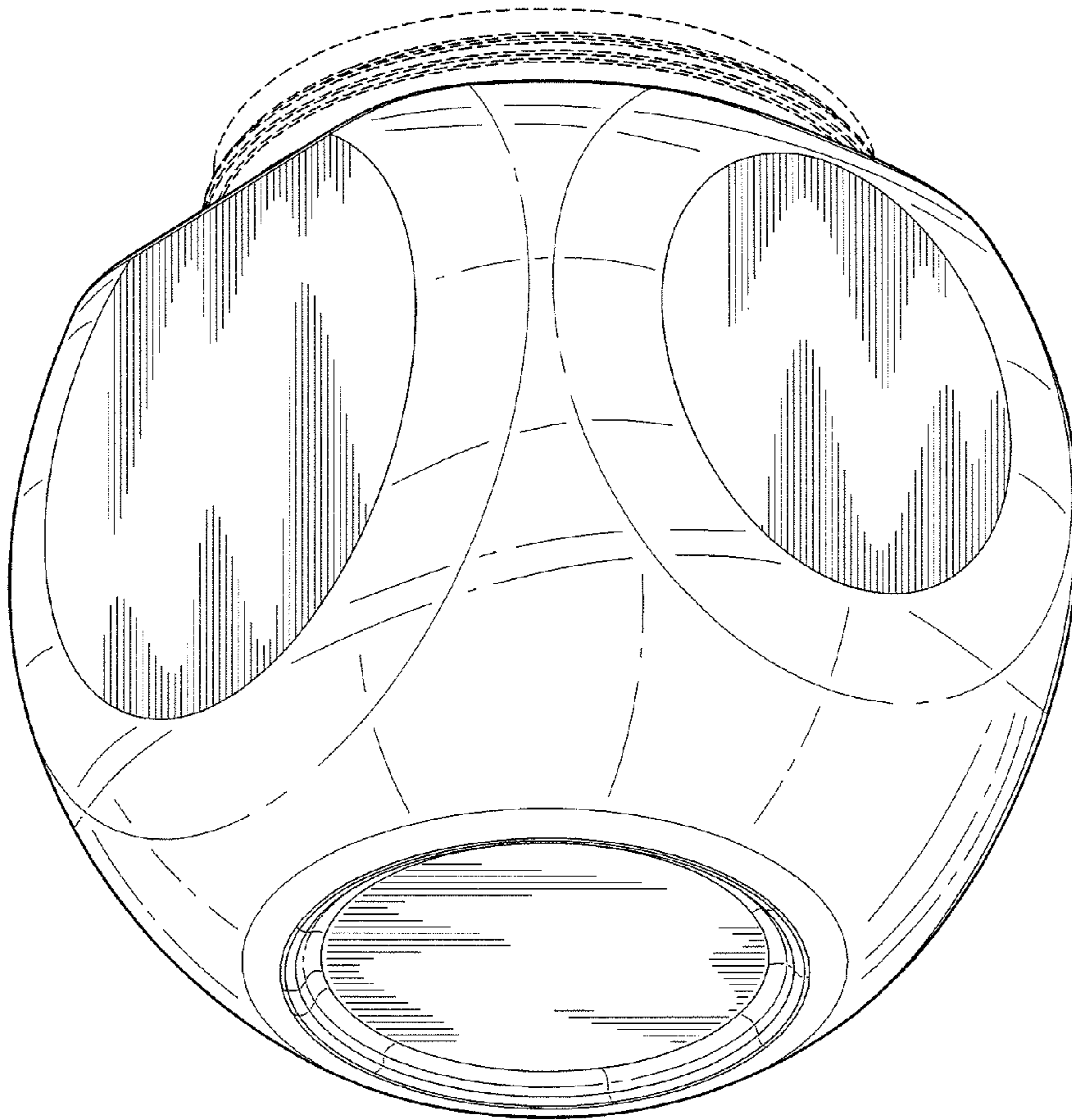

FIG. 10

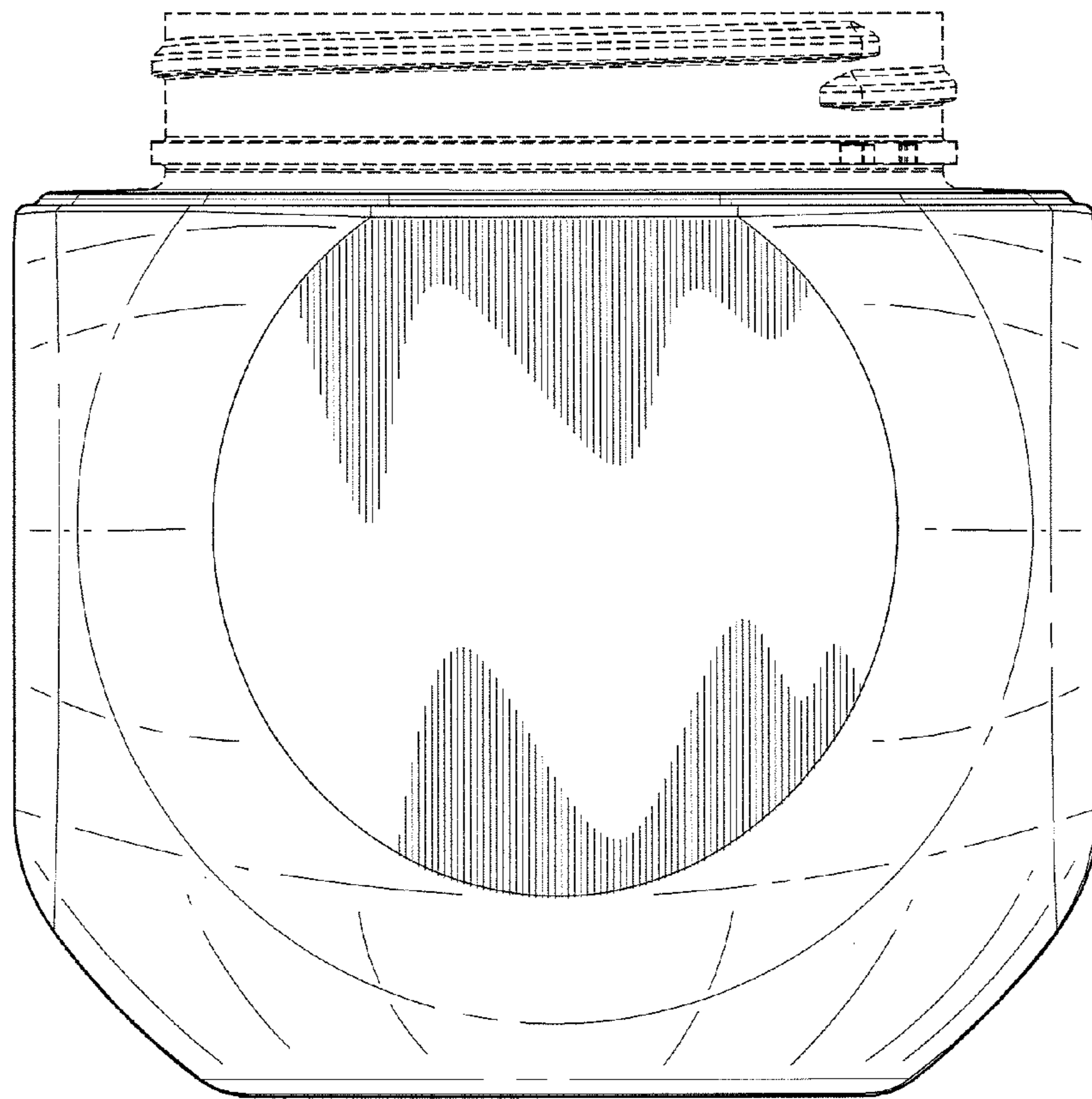

FIG. 11

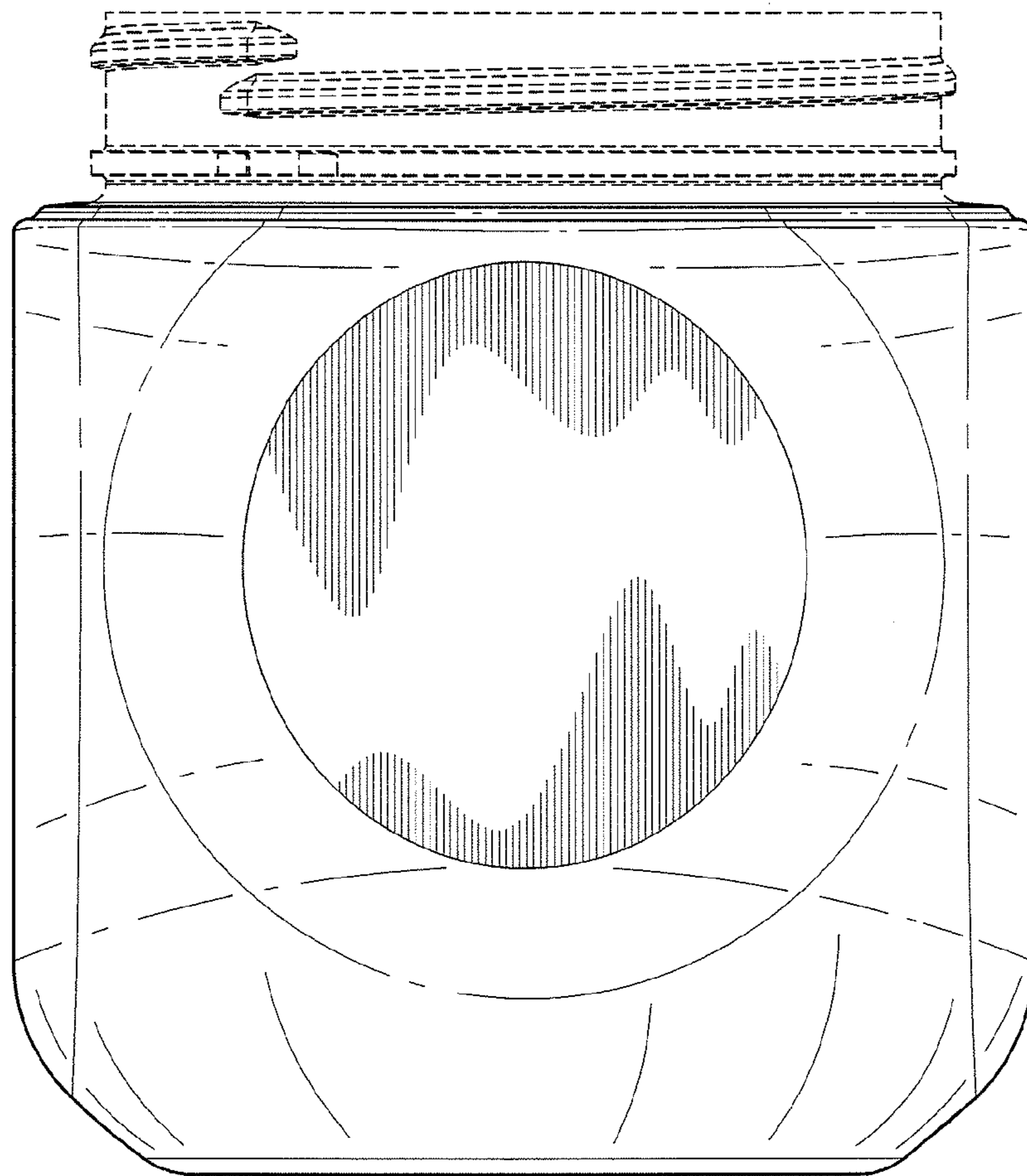

FIG. 12

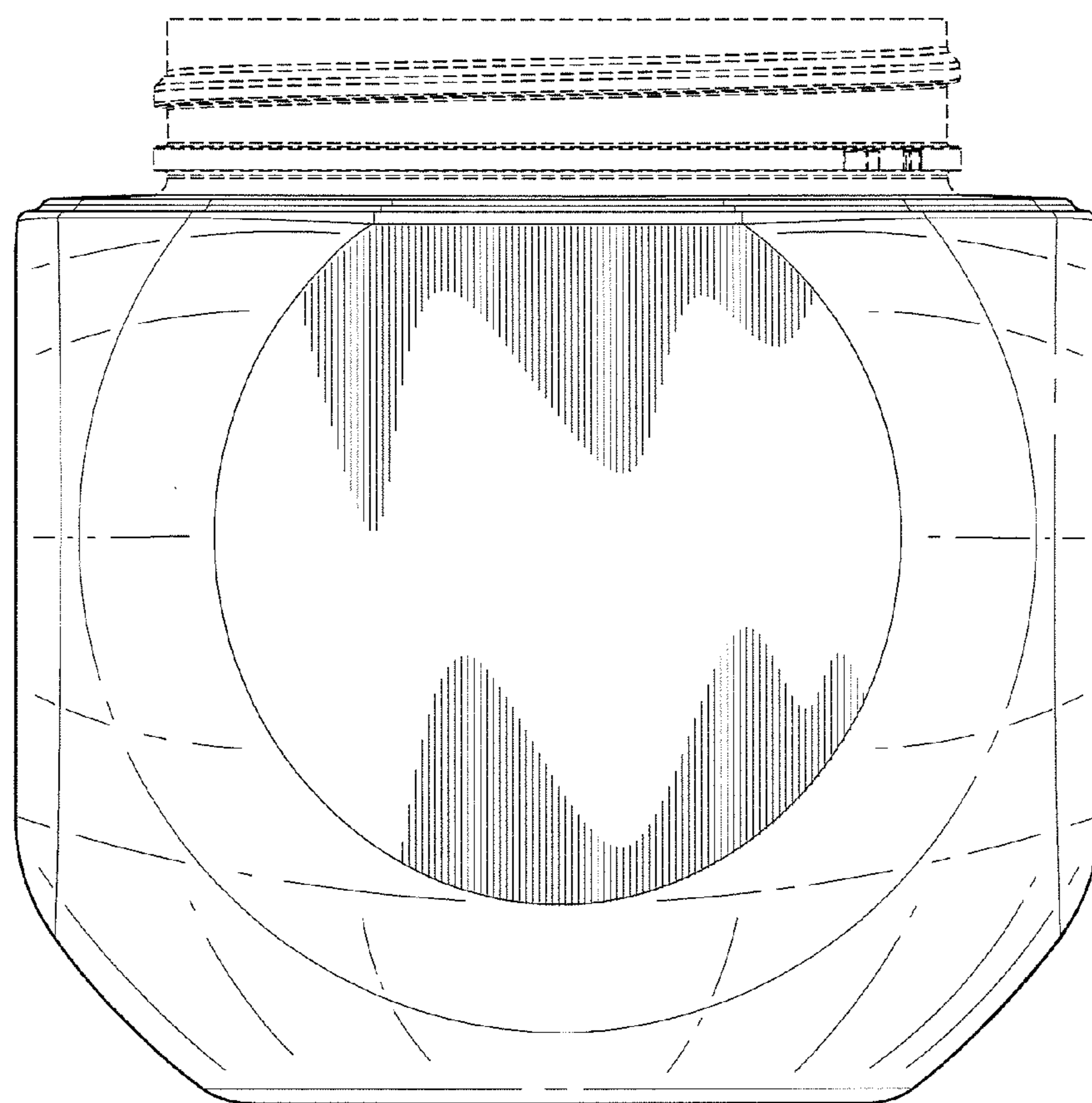

FIG. 13

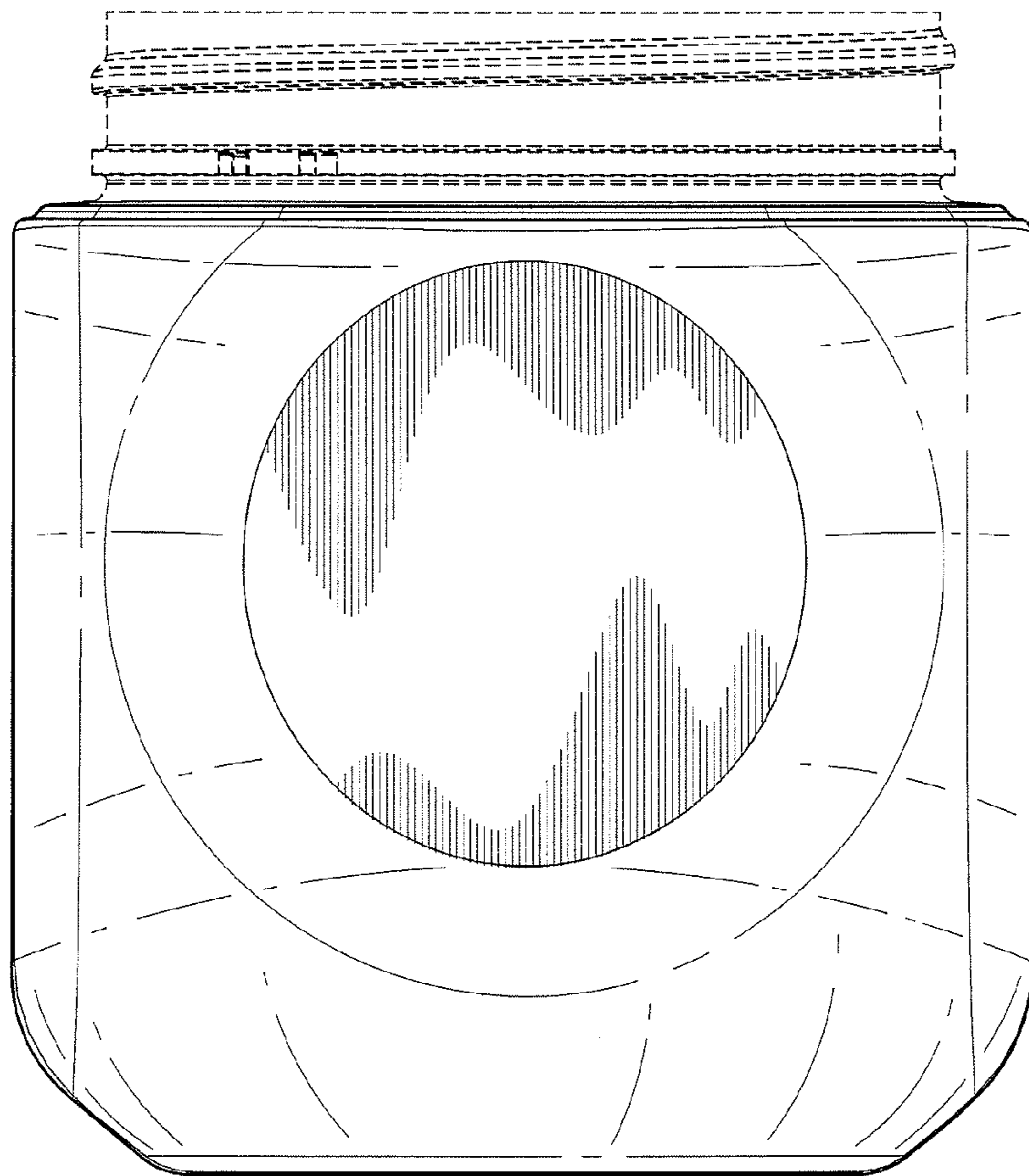

FIG. 14

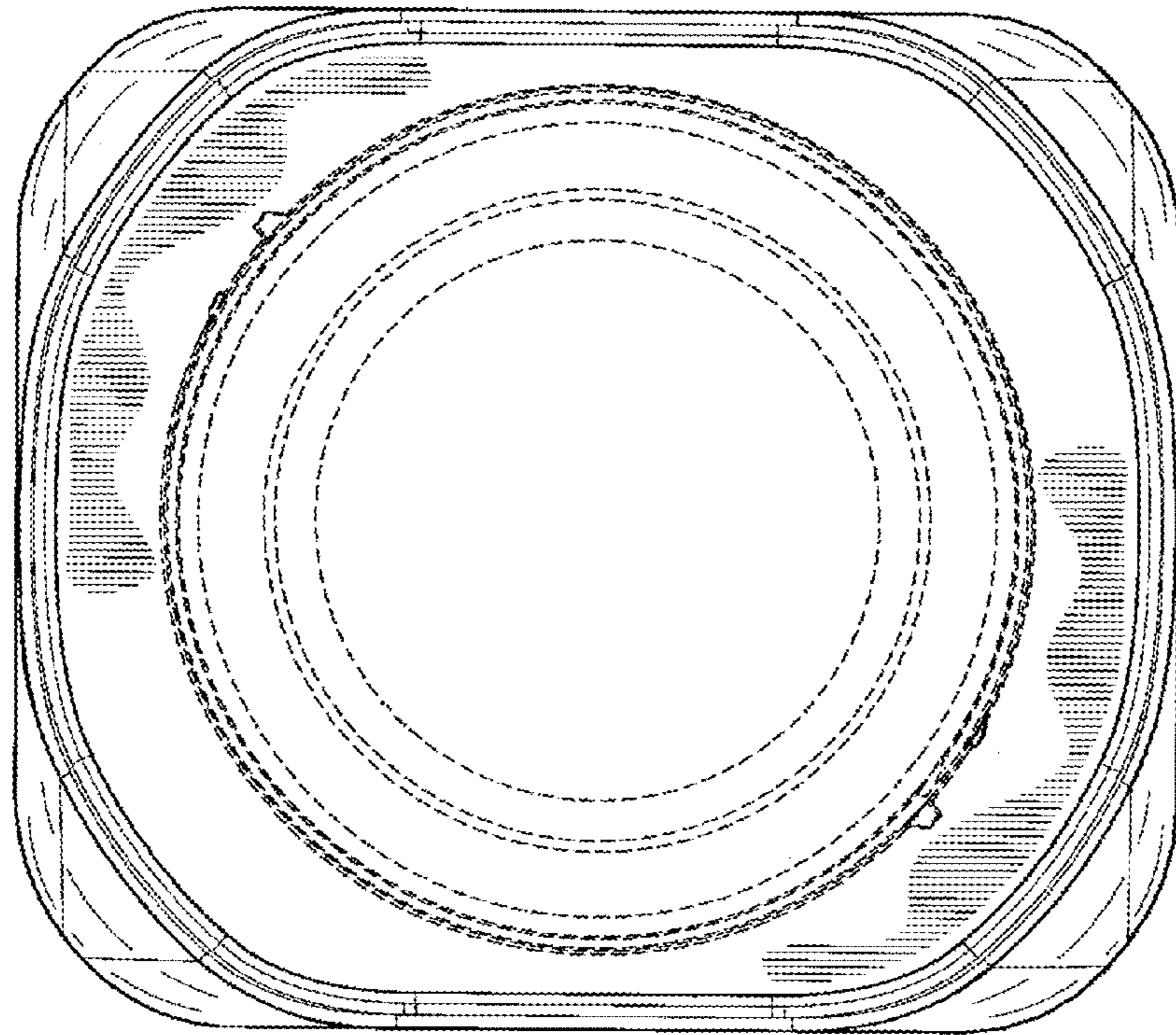

FIG. 15

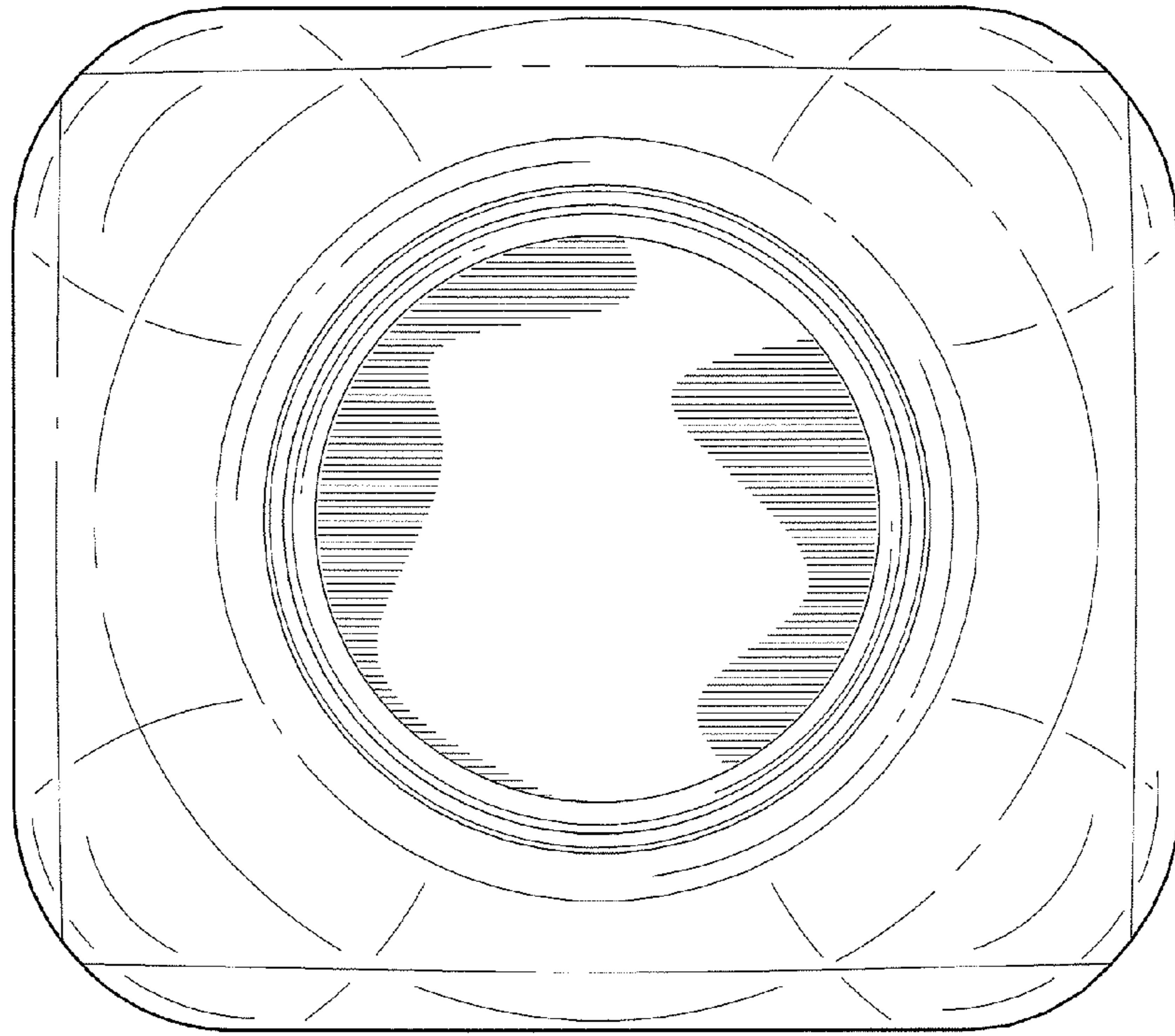

FIG. 16