



US00D743542S

(12) **United States Design Patent**
Degen

(10) **Patent No.:** **US D743,542 S**
(45) **Date of Patent:** **** Nov. 17, 2015**

- (54) **CATHETER WITH STAGGERED SLITS**
- (71) Applicant: **Sequana Medical AG**, Zug (CH)
- (72) Inventor: **Thomas Degen**, Bermensdorf (CH)
- (73) Assignee: **SEQUANA MEDICAL AG**, Zug (CH)
- (**) Term: **14 Years**
- (21) Appl. No.: **29/436,041**
- (22) Filed: **Oct. 31, 2012**
- (51) **LOC (10) Cl.** **24-01**
- (52) **U.S. Cl.**
USPC **D24/130**
- (58) **Field of Classification Search**
USPC D24/2-114, 133, 186; 606/181, 185;
604/264, 272, 115, 232, 187, 158,
604/164.08, 192, 263, 163, 181, 184, 198,
604/227; 600/101, 139, 143; 128/200.24,
128/207.14, 207.15

See application file for complete search history.

(56) **References Cited**

U.S. PATENT DOCUMENTS

- 4,398,910 A 8/1983 Blake et al.
- 4,465,481 A 8/1984 Blake

(Continued)

OTHER PUBLICATIONS

U.S. Appl. No. 29/436,050, filed Oct. 31, 2012, Degen Thomas Werner.

Primary Examiner — David Muller

Assistant Examiner — Nathan Johnston

(74) *Attorney, Agent, or Firm* — Foley & Lardner LLP; Kiri Lee Sharon; Nicola A. Pisano

(57) **CLAIM**

I claim the ornamental design for a catheter with staggered slits, as shown and described.

DESCRIPTION

FIG. 1 is an elevation view of a catheter with staggered slits showing my new design, in which the lighter lines in the region that is designated "FIG. 8" indicate a slit that is on the underside of the catheter;

FIG. 2 is an elevation view of the catheter showing additional detail in the region of FIG. 1 that is designated "FIG. 2";

FIG. 3 is a cross-sectional view of the catheter taken along line 3-3 in FIG. 2;

FIG. 4 is an elevation view of the catheter showing additional detail in the region of FIG. 1 that is designated "FIG. 4;"

FIG. 5 is a cross-sectional view of the catheter taken along line 5-5 of FIG. 4;

FIG. 6 is an elevation view of the catheter showing additional detail in the region of FIG. 1 that is designated "FIG. 6;"

FIG. 7 is a cross-sectional view of the catheter taken along line 7-7 in FIG. 6;

FIG. 8 is an elevation view of the catheter showing additional detail in the region of FIG. 1 that is designated "FIG. 8," and in which the lighter lines indicate a slit that is on the underside of the catheter;

FIG. 9 is a cross-sectional view of the catheter taken along line 9-9 in FIG. 8;

FIG. 10 is an elevation view of the catheter showing additional detail in the region of FIG. 1 that is designated "FIG. 10," and in which the lighter lines indicate slits that are on the underside of the catheter;

FIG. 11 is a cross-sectional view of the catheter taken along line 11-11 in FIG. 10;

FIG. 12 is an elevation view of the catheter showing additional detail in the region of FIG. 1 that is designated "FIG. 12," and in which the lighter lines indicate slits that are on the underside of the catheter;

FIG. 13 is a cross-sectional view of the catheter taken along line 13-13 in FIG. 12;

FIG. 14 is an elevation view of the catheter showing additional detail in the region of FIG. 1 that is designated "FIG. 14," and in which the lighter lines indicate slits that are on the underside of the catheter; and,

FIG. 15 is a cross-sectional view of the catheter taken along line 15-15 in FIG. 14.

The interior edges of the slits and interior surface of the tube are not shown in the drawings for clarity of illustration. The dash-dot lines in FIG. 1 show the boundaries of the claimed design within the interior of the catheter, and form no part of the claimed design.

1 Claim, 8 Drawing Sheets

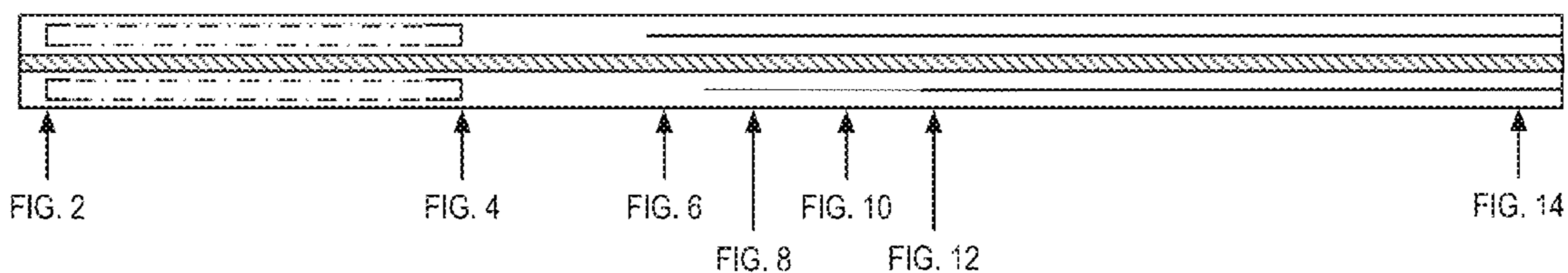

(56)

References Cited

U.S. PATENT DOCUMENTS

D303,840 S *	10/1989	Weilbacher	D24/112	D558,342 S	12/2007	Fujiwara et al.	
5,593,394 A *	1/1997	Kanesaka et al.	604/524	7,311,690 B2	12/2007	Burnett	
5,676,670 A *	10/1997	Kim	606/108	7,335,179 B2	2/2008	Burnett	
5,713,864 A *	2/1998	Verkaart	604/113	8,202,248 B2	6/2012	Burnett et al.	
6,099,513 A	8/2000	Spehalski		8,398,577 B2	3/2013	Burnett	
6,146,354 A *	11/2000	Beil	604/28	8,585,635 B2	11/2013	Degen et al.	
6,478,789 B1	11/2002	Spehalski et al.		2002/0091352 A1	7/2002	McGuckin et al.	
6,966,889 B2 *	11/2005	Saab	604/96.01	2007/0208323 A1 *	9/2007	Gregorich et al.	604/523
6,976,973 B1	12/2005	Ruddell et al.		2007/0233042 A1 *	10/2007	Moehle et al.	604/523
6,986,752 B2	1/2006	McGuckin et al.		2009/0054874 A1 *	2/2009	Barron et al.	604/524
D558,338 S *	12/2007	Itoh	D24/130	2012/0209165 A1	8/2012	Degen et al.	
D558,341 S	12/2007	Fujiwara et al.		2013/0317476 A1 *	11/2013	Searle et al.	604/506
				2014/0121590 A1 *	5/2014	Degen	604/28
				2014/0213966 A1 *	7/2014	Ostapoff et al.	604/93.01

* cited by examiner

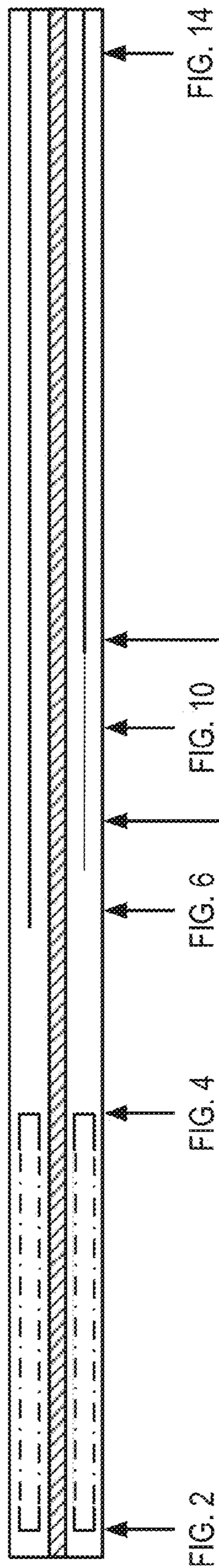

FIG. 1

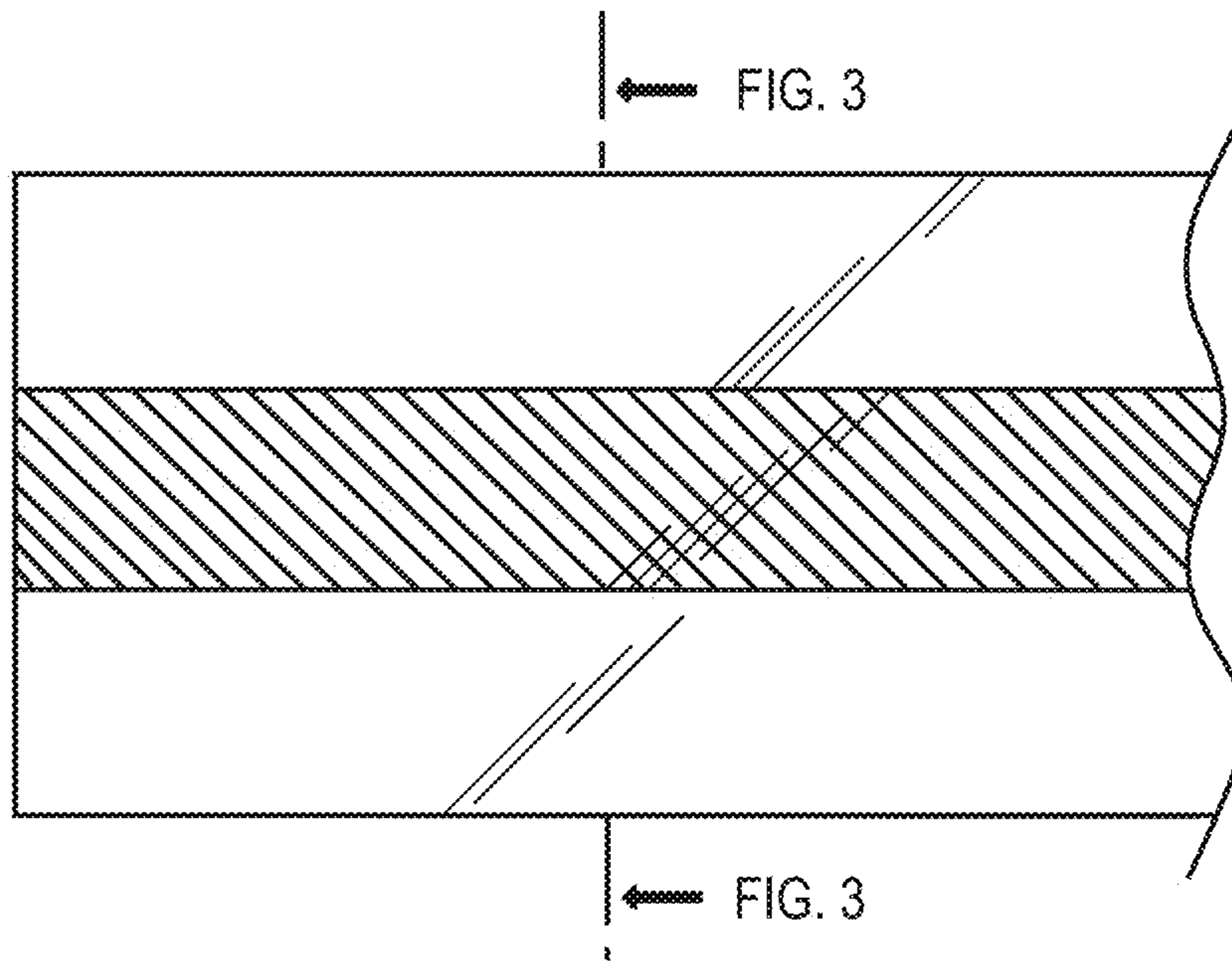

FIG. 2

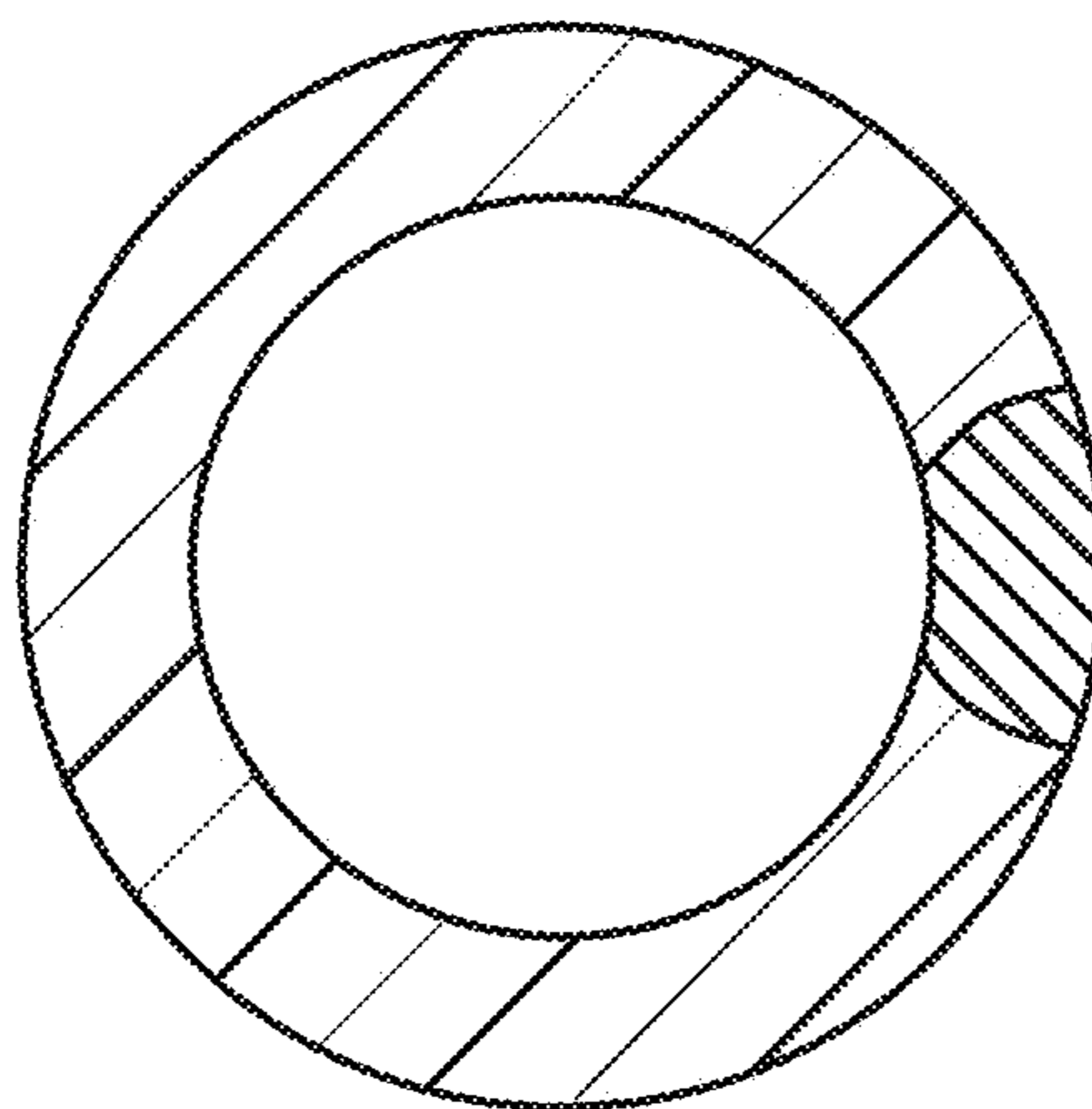

FIG. 3

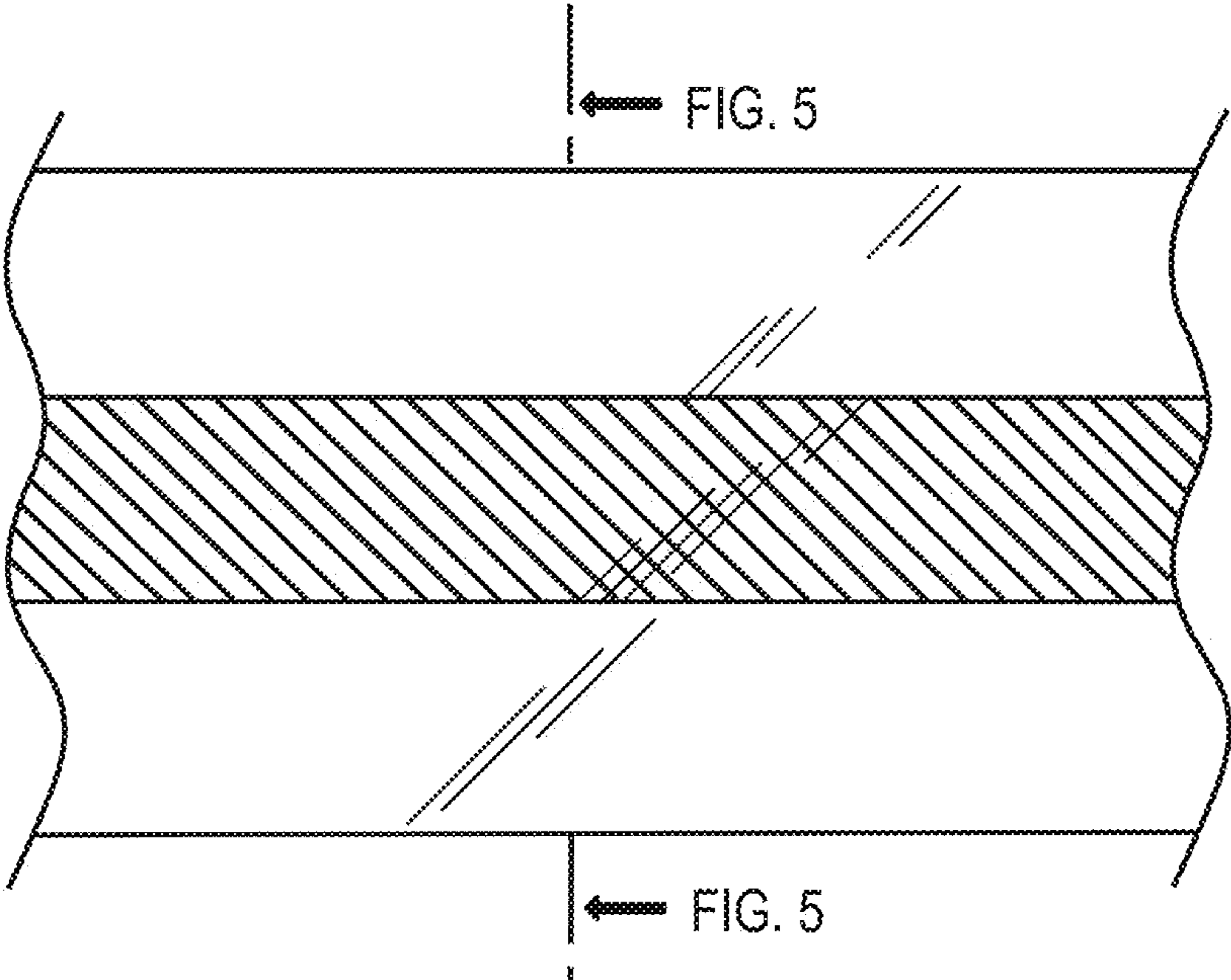

FIG. 4

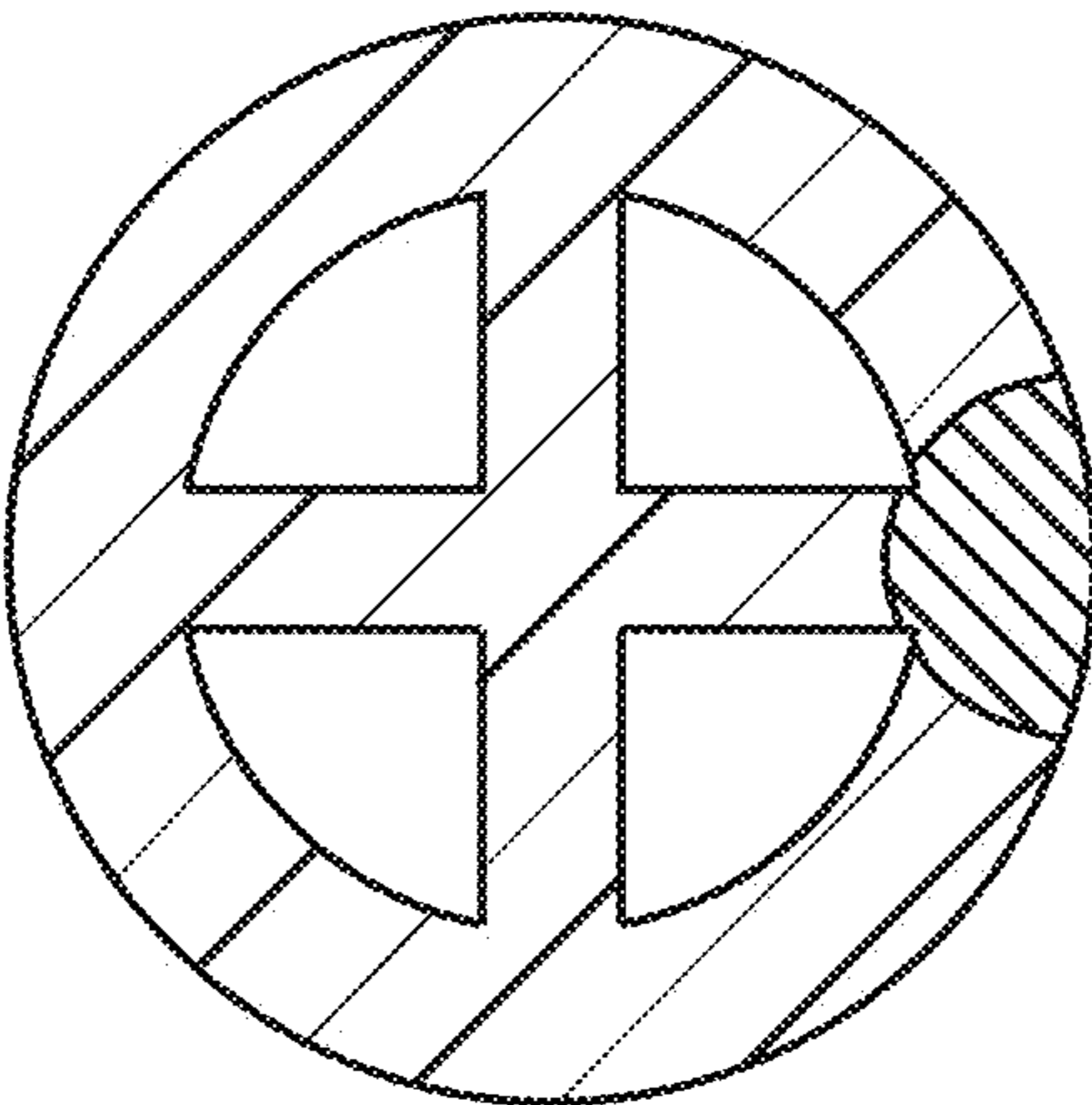

FIG. 5

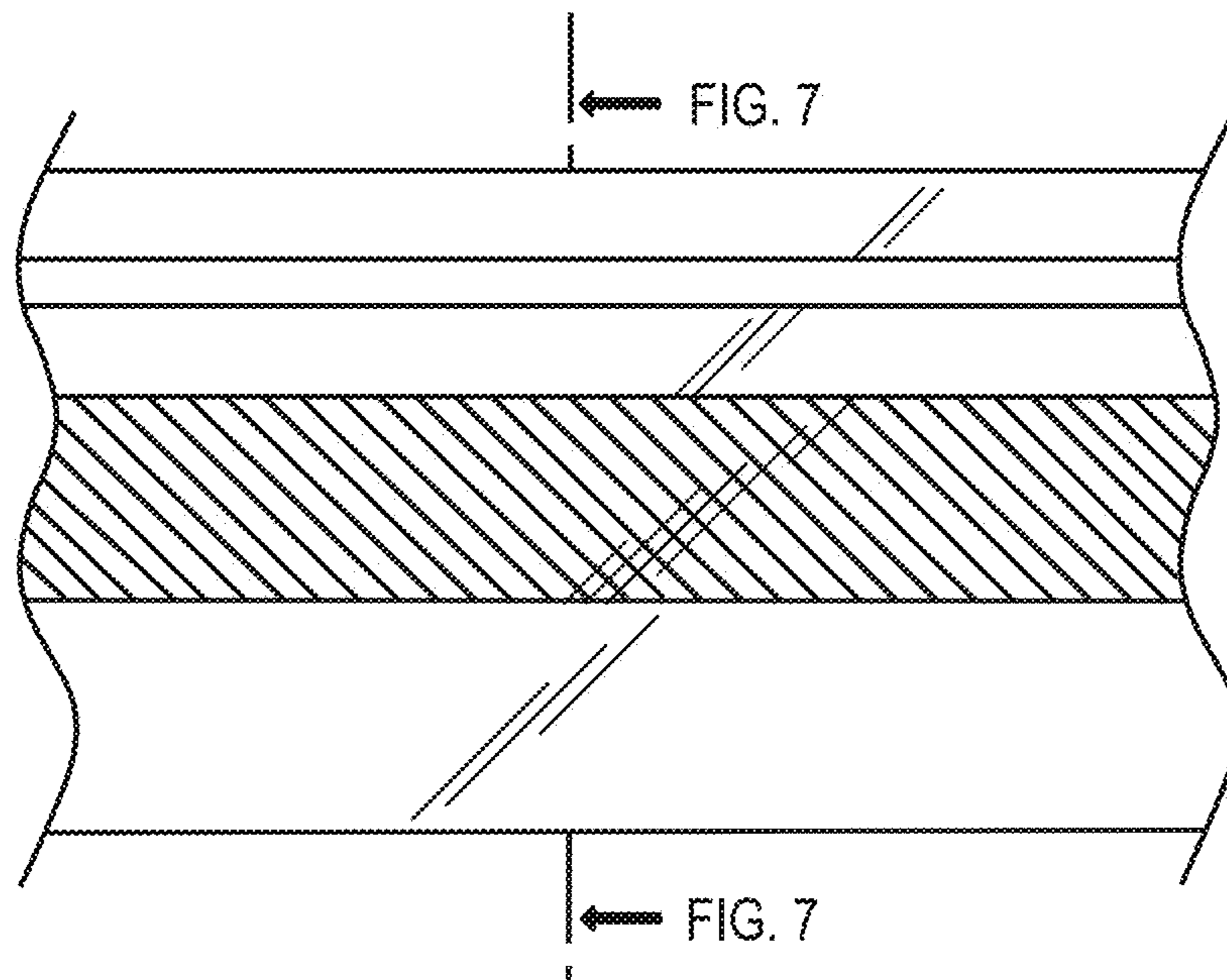

FIG. 6

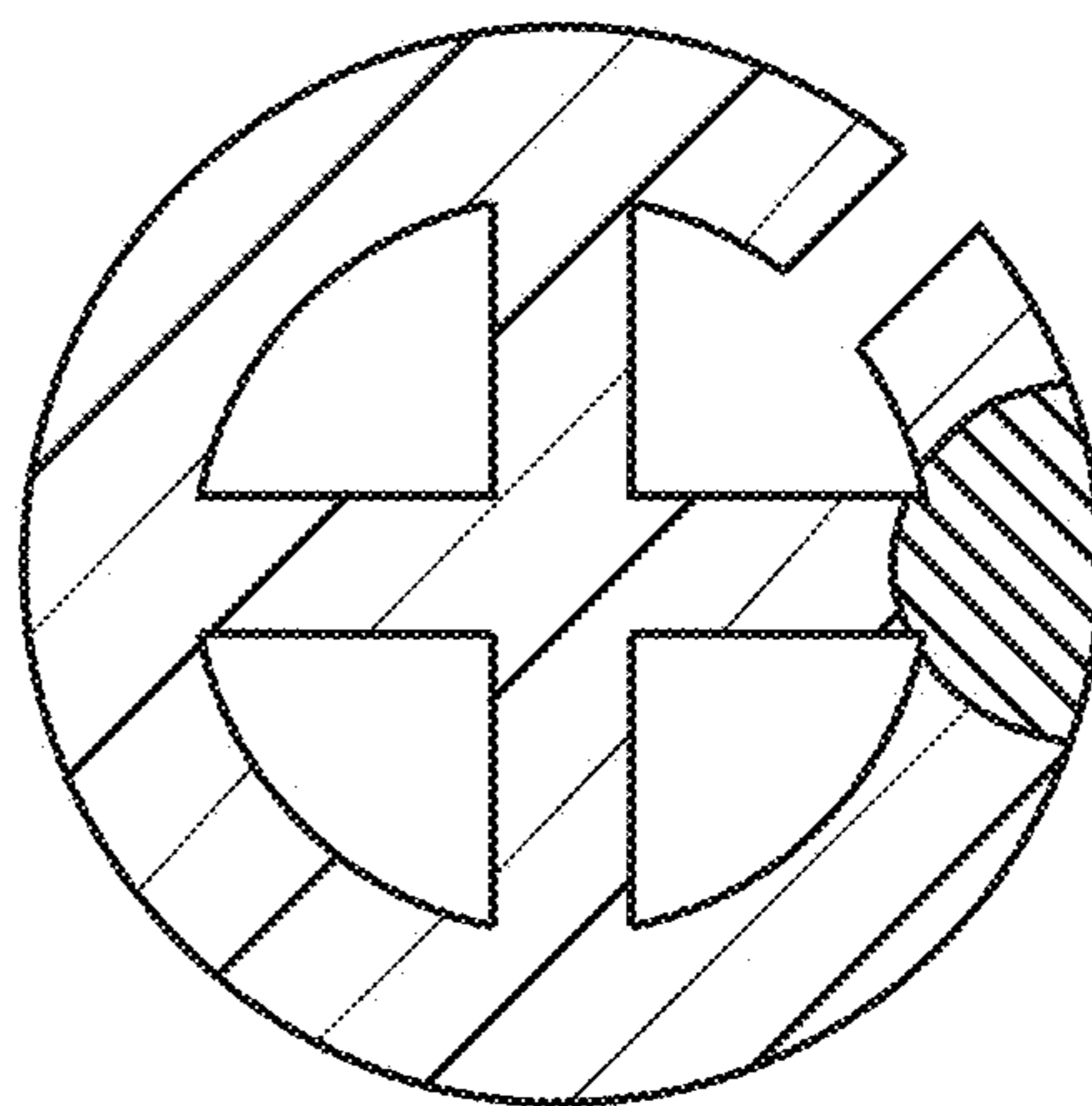

FIG. 7

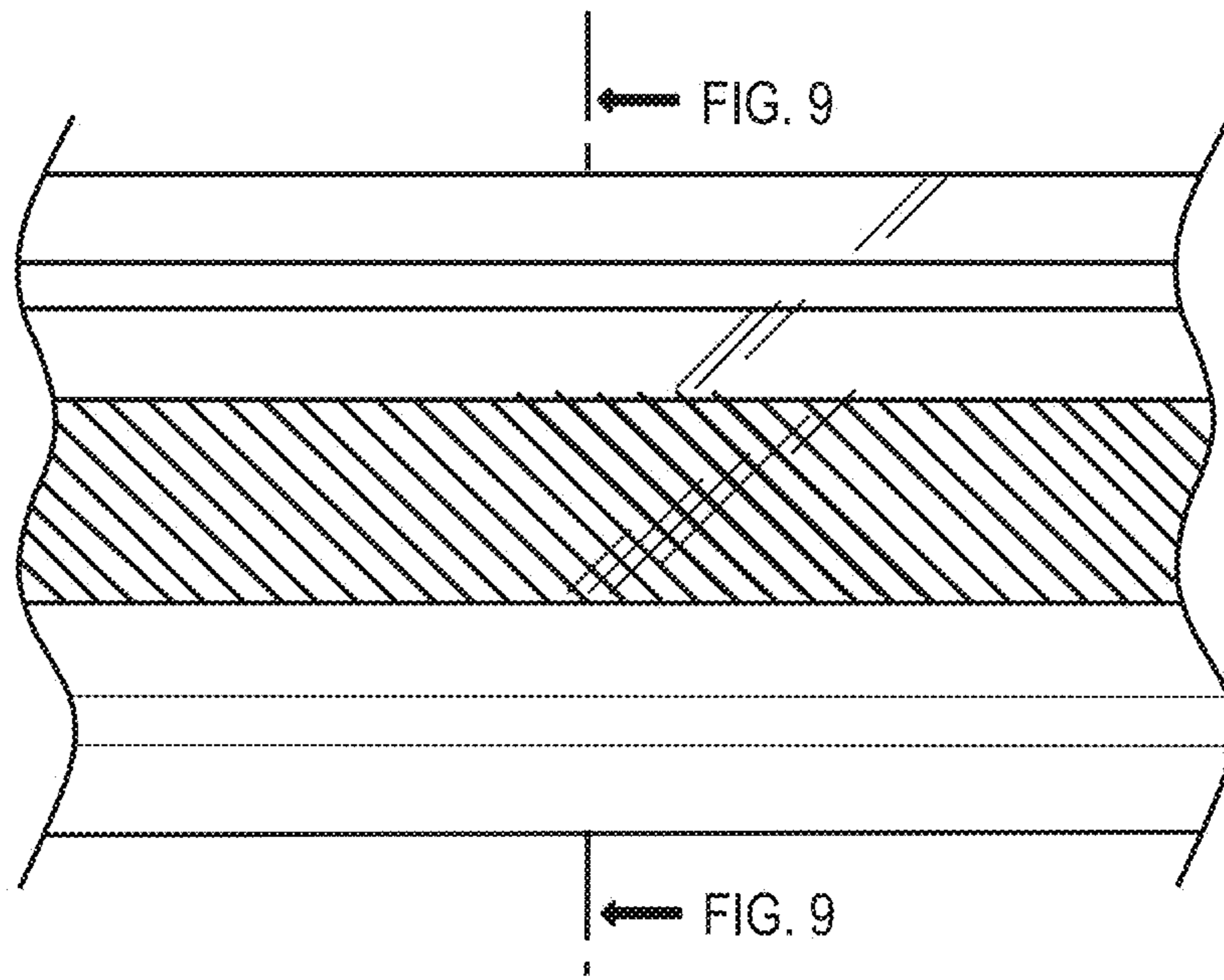

FIG. 8

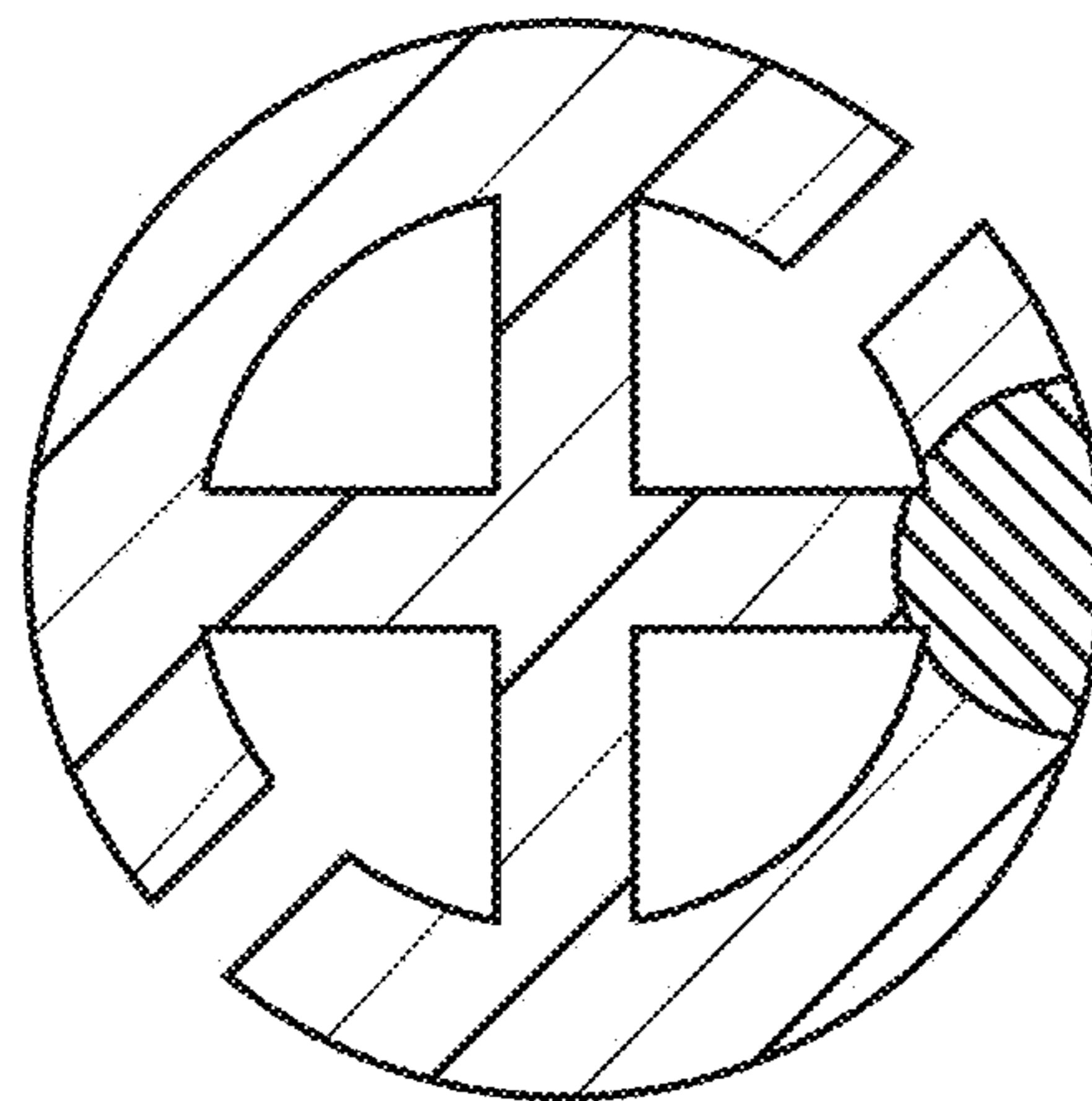

FIG. 9

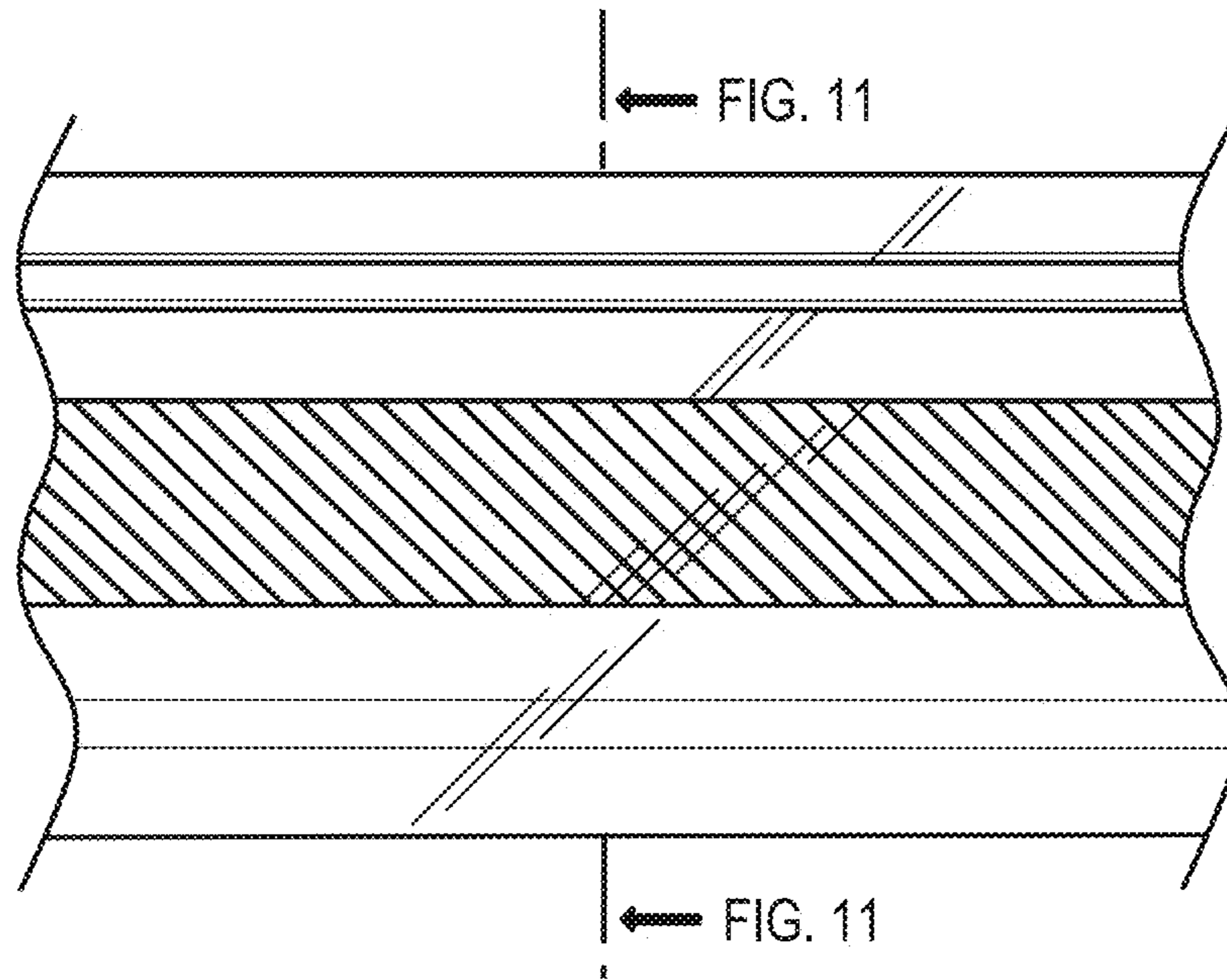

FIG. 10

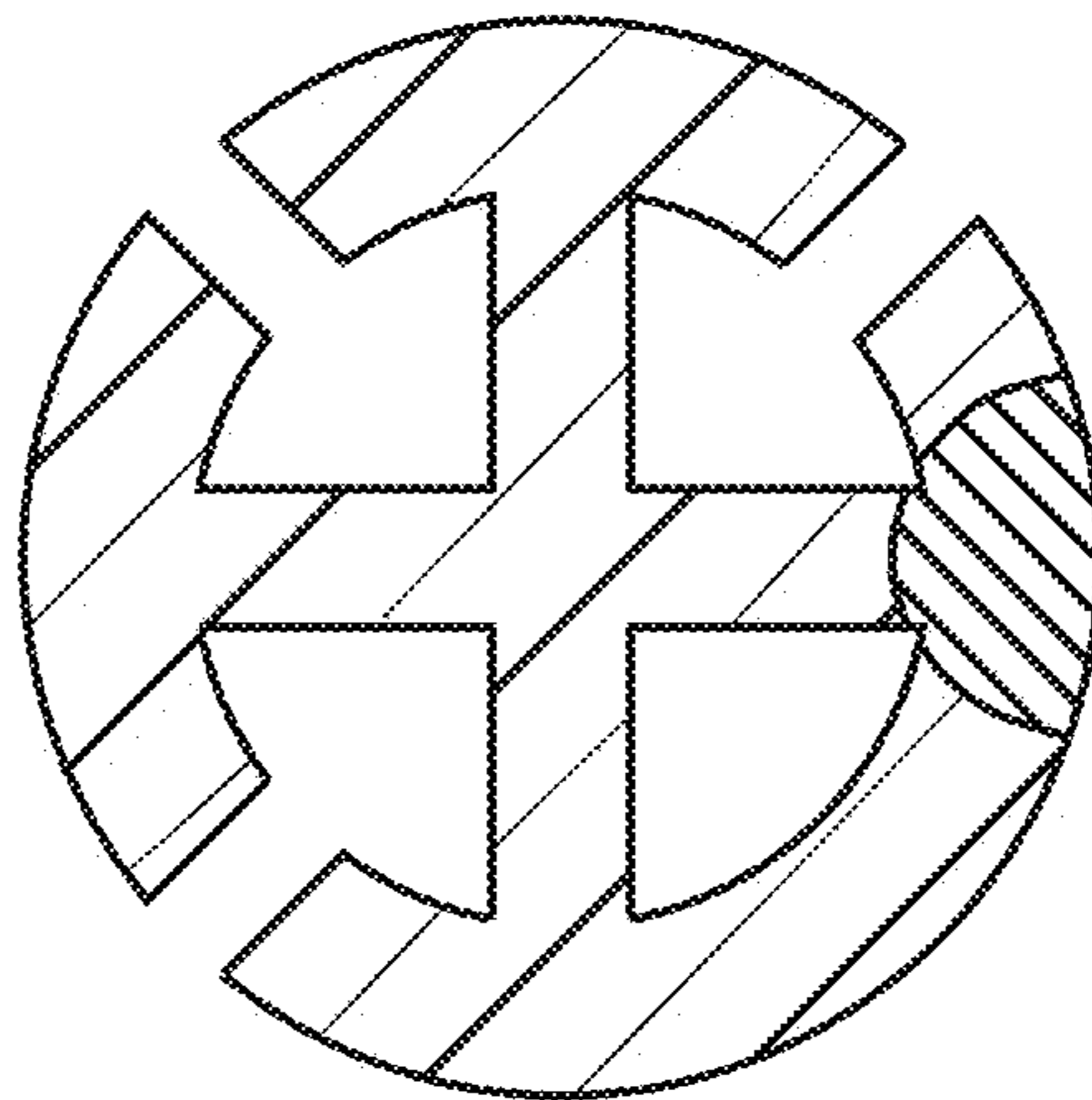

FIG. 11

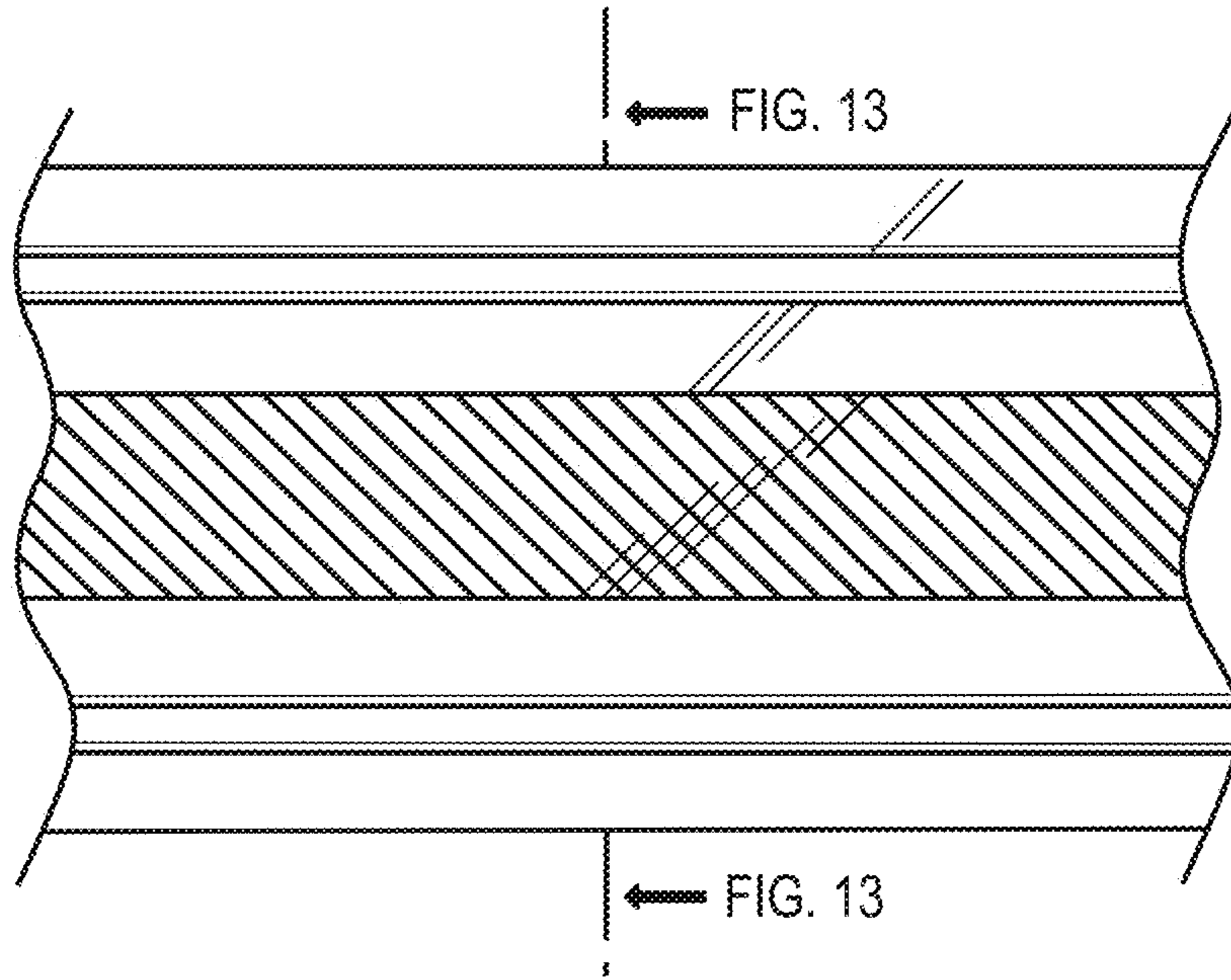

FIG. 12

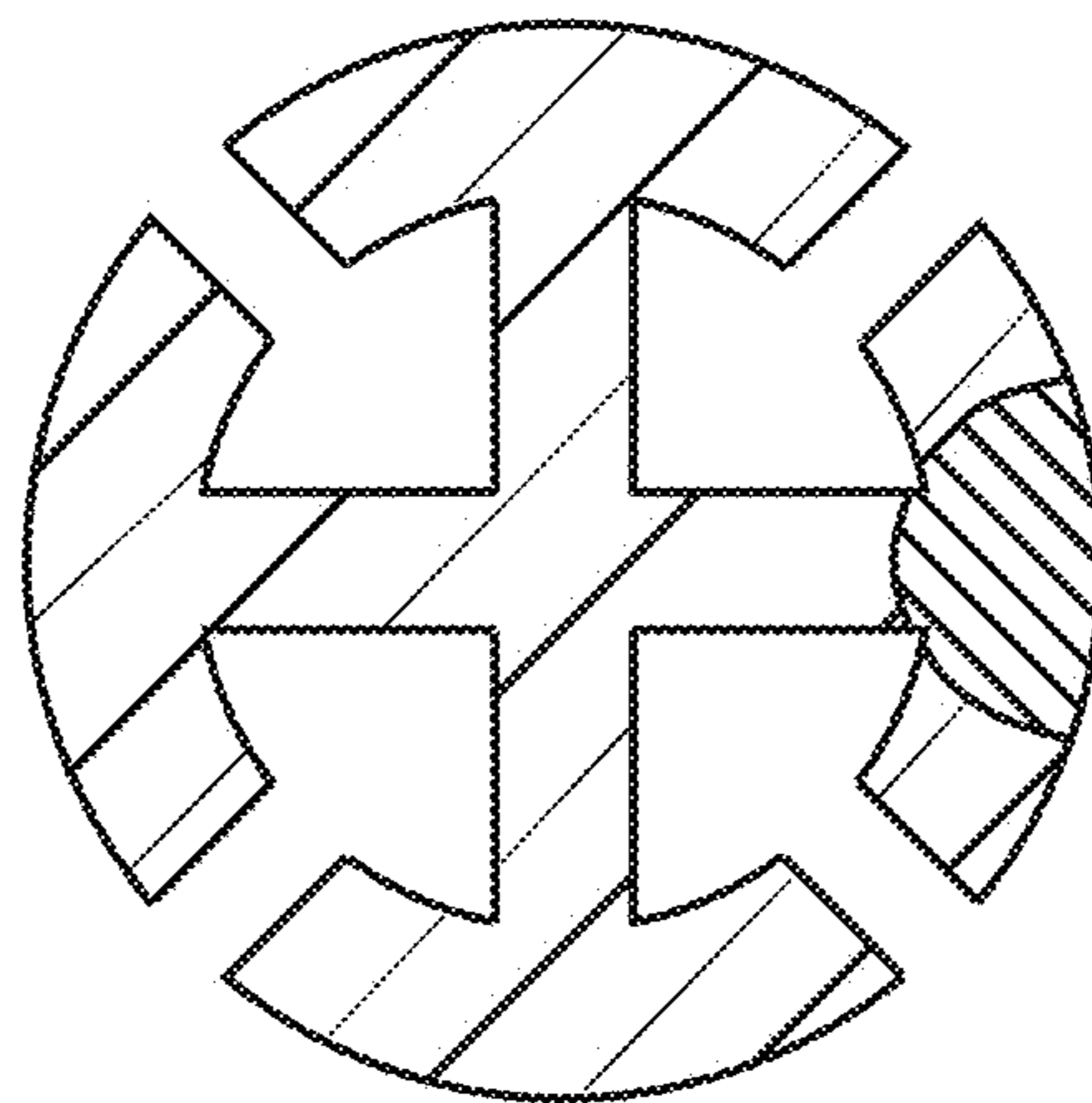

FIG. 13

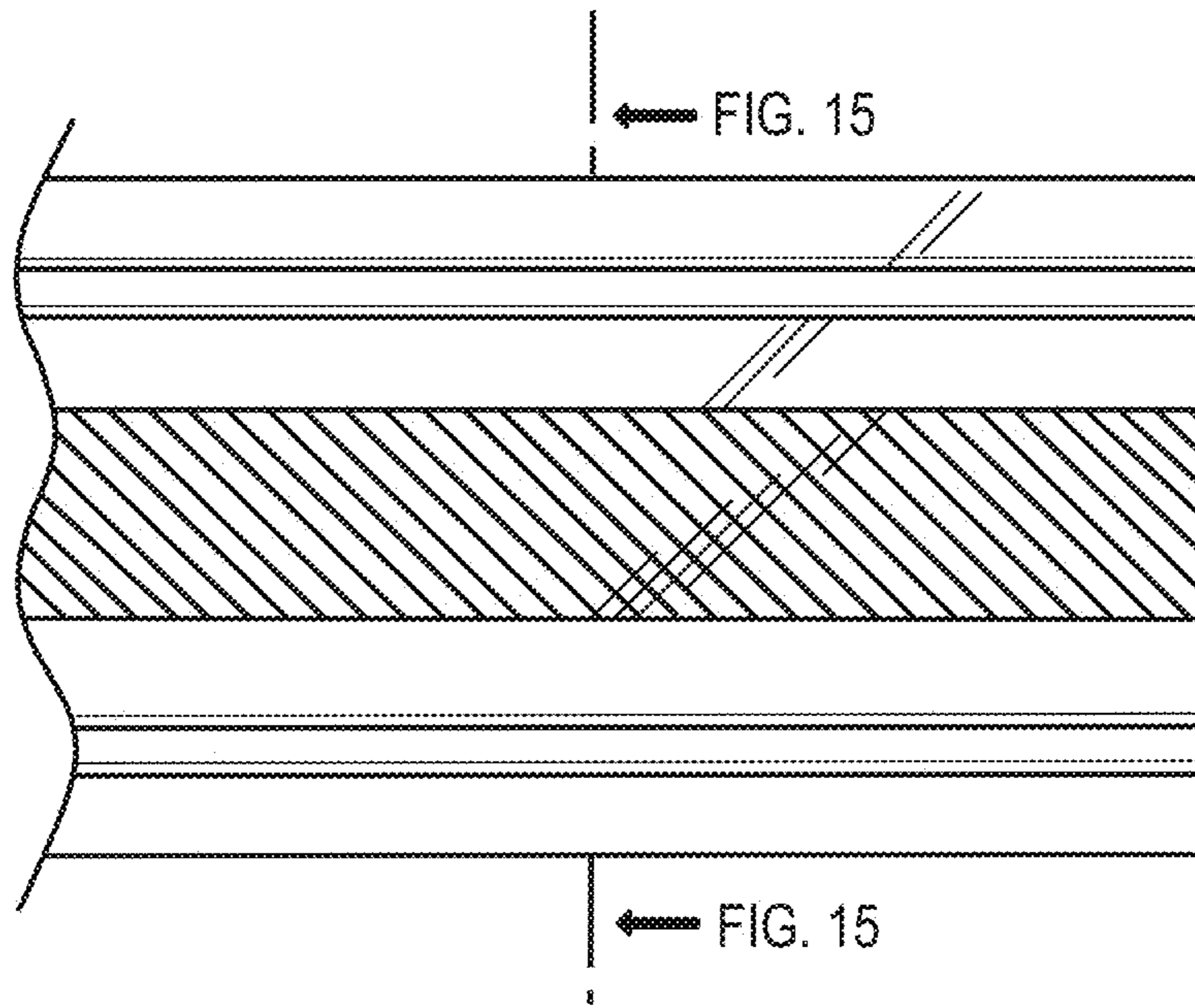

FIG. 14

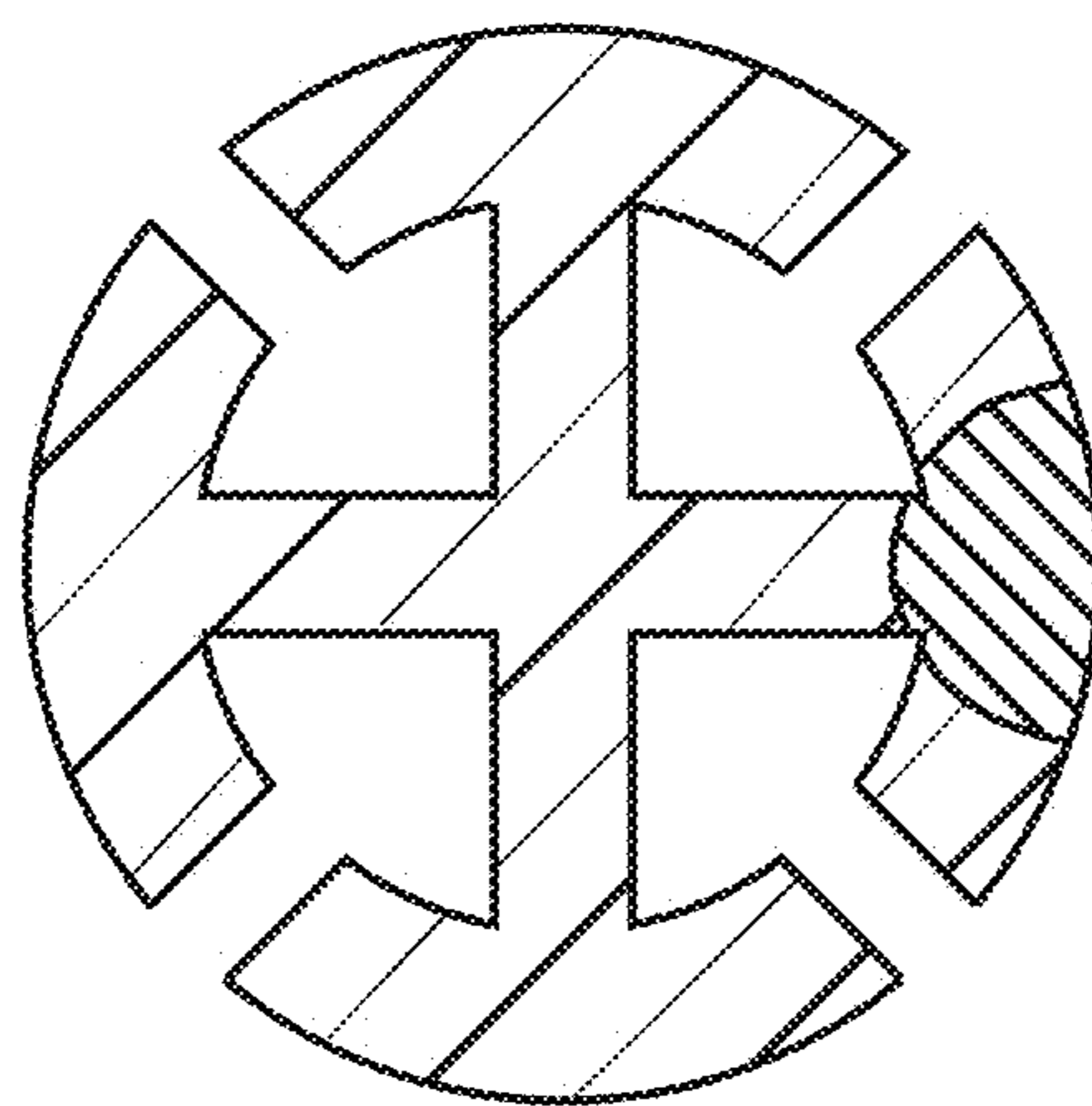

FIG. 15