



US00D743510S

(12) **United States Design Patent**
Lombardi, III

(10) **Patent No.:** **US D743,510 S**

(45) **Date of Patent:** **** Nov. 17, 2015**

(54) **HIGH PRESSURE FLUID CONDUIT
CONNECTOR COMPONENTS AND
CONNECTOR ASSEMBLY**

(71) Applicant: **Nordson Corporation**, Westlake, OH
(US)

(72) Inventor: **Francis J. Lombardi, III**, Erie, CO
(US)

(73) Assignee: **Nordson Corporation**, Westlake, OH
(US)

(**) Term: **14 Years**

(21) Appl. No.: **29/476,030**

(22) Filed: **Dec. 10, 2013**

Related U.S. Application Data

(63) Continuation-in-part of application No. 14/068,703,
filed on Oct. 31, 2013.

(51) **LOC (10) Cl.** **23-01**

(52) **U.S. Cl.**
USPC **D23/262**

(58) **Field of Classification Search**
USPC D23/262, 260, 233; D24/129; D11/216,
D11/218; 601/152; 285/124.4, 185, 187,
285/124.5, 256, 308, 305, 311; 439/352,
439/357, 353; 24/616; 137/614.05, 15.09,
137/625.46; 600/5

CPC A61H 9/007; F16L 37/56; F16L 37/088;
F16L 37/00; F16L 37/0841; F16L 37/0982;
H01R 13/641; H01R 13/6272; A61F 7/02;
A61M 5/14276; A61M 39/10; A61M 39/105;
A61M 5/007; F16K 11/085

See application file for complete search history.

(56) **References Cited**

U.S. PATENT DOCUMENTS

3,933,406 A 1/1976 Cameron et al.
4,280,485 A 7/1981 Arkans
4,320,746 A * 3/1982 Arkans A61H 9/0078
601/152
4,804,208 A * 2/1989 Dye F16L 37/56
285/124.4

4,946,404 A * 8/1990 Takenouchi H01R 13/641
439/352
4,982,736 A 1/1991 Schneider
D319,312 S * 8/1991 Schneider D24/129
5,117,812 A * 6/1992 McWhorter A61H 9/0078
128/DIG. 20
D327,738 S * 7/1992 Dye D24/127
D330,250 S * 10/1992 Dye D24/129
5,219,185 A * 6/1993 Oddenino F16L 37/088
285/187
5,242,425 A 9/1993 White et al.
5,246,380 A * 9/1993 Kodama H01R 13/6272
24/616
5,462,450 A * 10/1995 Kodama H01R 13/641
439/357
5,478,119 A 12/1995 Dye
D369,664 S * 5/1996 Dye D23/260
D369,859 S * 5/1996 Ribando D24/129
D373,191 S * 8/1996 Ribando D24/129
D379,161 S * 5/1997 Matoba D11/216
D401,533 S * 11/1998 Anscher D11/218
5,980,297 A * 11/1999 Sugie H01R 13/6272
439/353
5,984,378 A 11/1999 Ostrander et al.
D423,985 S * 5/2000 Yoshiguchi D11/218
D424,978 S * 5/2000 Yoshiguchi D11/218
6,062,244 A 5/2000 Arkans
6,402,204 B1 6/2002 Stuart et al.
D471,130 S * 3/2003 Lai D11/216
D496,304 S * 9/2004 Uehara D11/216
D508,431 S 8/2005 Yoshiguchi
D519,878 S * 5/2006 Anscher D11/216
D524,693 S * 7/2006 Uehara D11/216
7,434,842 B2 * 10/2008 Schmidt F16L 37/0841
285/308
7,490,620 B2 * 2/2009 Tesluk A61M 39/105
137/15.09
D595,845 S * 7/2009 Mros D24/129
D599,478 S * 9/2009 Bizup D24/128
D601,248 S * 9/2009 Mros D24/129
D650,478 S * 12/2011 Lewis D24/129
D652,511 S * 1/2012 Lombardi, III D24/129
8,092,409 B2 1/2012 Mros et al.
D655,393 S * 3/2012 Whitaker D23/233
8,257,286 B2 9/2012 Meyer et al.
2003/0193188 A1 * 10/2003 Miros A61F 7/02
285/124.5
2005/0242579 A1 * 11/2005 Bright A61M 5/14276
285/256
2007/0169825 A1 * 7/2007 Packham A61M 39/10
137/614.05
2008/0007051 A1 * 1/2008 Jensen F16L 37/00
285/305

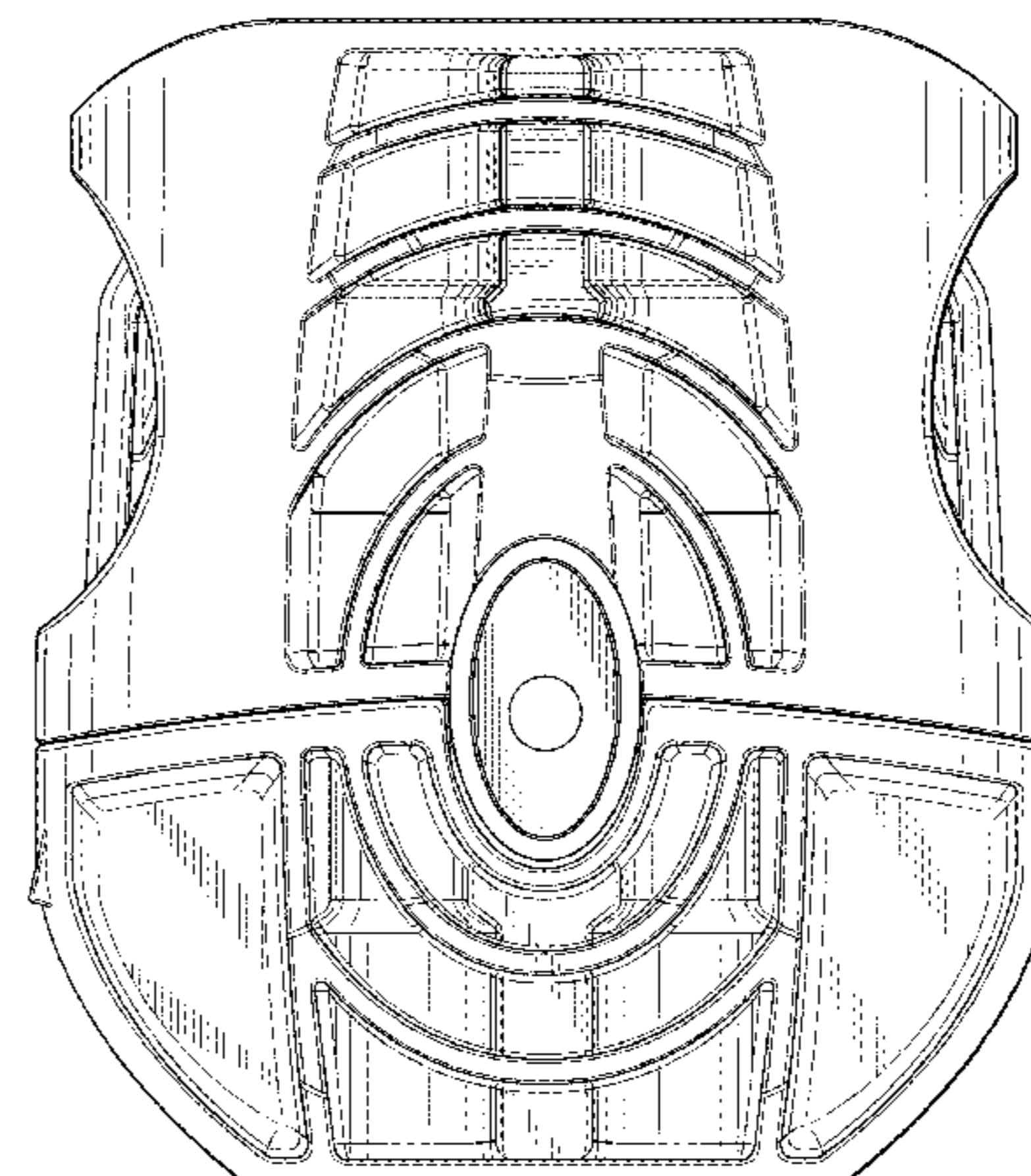
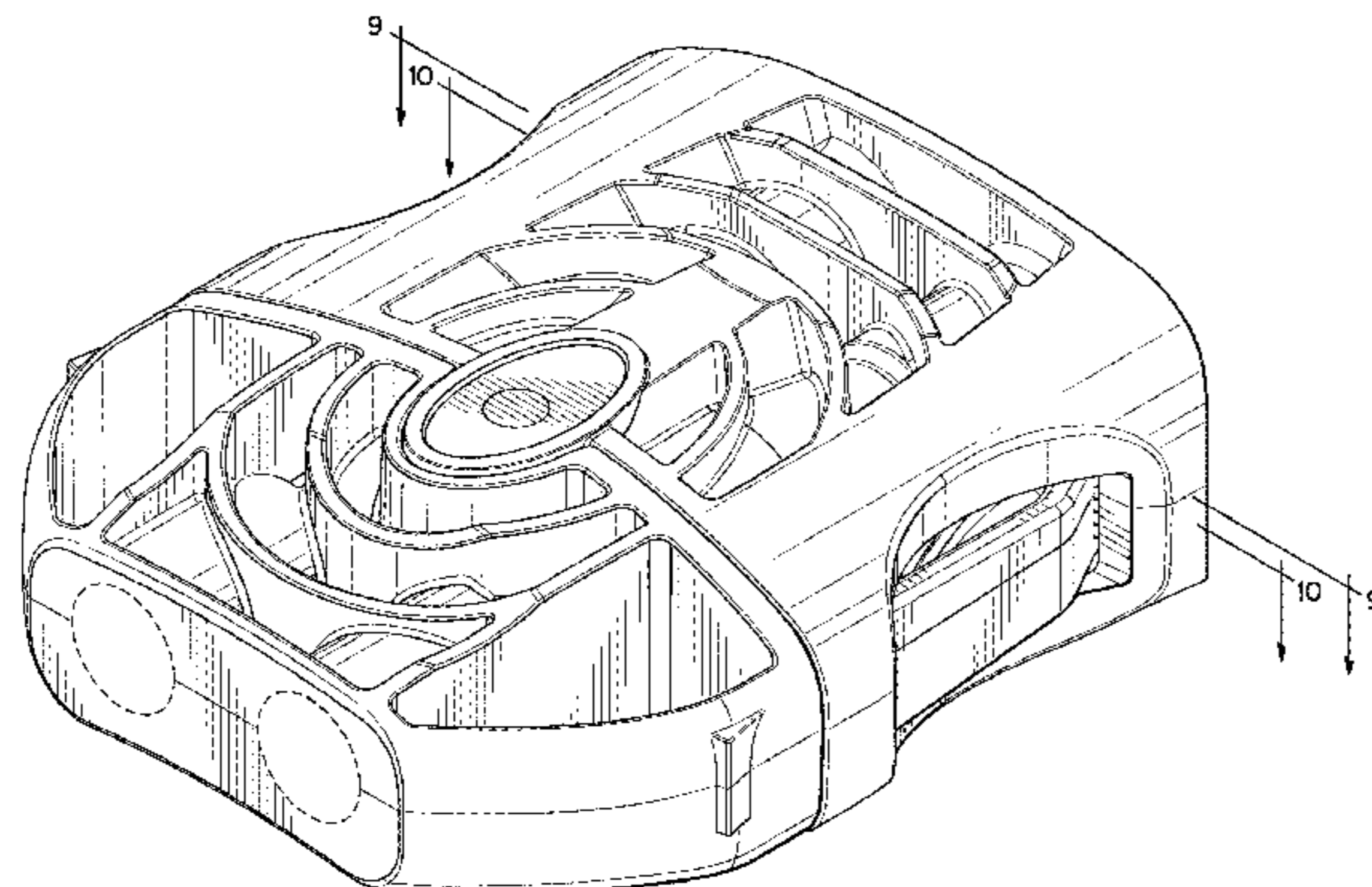

2010/0001516	A1*	1/2010	Pisula, Jr.	F16L 37/0982 285/311
2010/0185040	A1*	7/2010	Uber, III	A61M 5/007 600/5
2010/0319796	A1*	12/2010	Whitaker	F16K 11/085 137/625.46
2011/0204621	A1	8/2011	Whitaker et al.	
2011/0204622	A1	8/2011	Lewis et al.	
2011/0210541	A1	9/2011	Lewis et al.	

FOREIGN PATENT DOCUMENTS

EM	001304281-0001	*	12/2011
EP	2177808	A1	4/2010

OTHER PUBLICATIONS

Carbon Nanotubes and Other Nanomaterials Used To Make Wearable Artificial Kidney For Hemodialysis and Peritoneal Dialysis, Announced Apr. 25, 2010, [Site Visited Sep. 17, 2015] <http://www.ineffableisland.com/2010/04/carbon-nanotubes-and-other.html>.*

Composite Thermoplastic EMI/EMP Junction Boxes: Shipboard Interconnect and Conduit Solutions / Section E, Announced Aug. 17, 2010, [Site Visited Sep. 17, 2015] http://www.glenair.com/shipboard_interconnect_and_conduit_solutions/e.htm.*

Value Plastics, Inc. The SBL Series Quick Connects, SBL001/SG0109, Bar Code 8026-1-1-1/1 (2000) (2 pages).

* cited by examiner

Primary Examiner — Eric Goodman
Assistant Examiner — Luqman McNeil
 (74) *Attorney, Agent, or Firm* — Wood, Herron & Evans, LLP

(57) **CLAIM**

The ornamental design for a high pressure fluid conduit connector components and connector assembly therefor, as shown and described.

DESCRIPTION

FIG. 1 is a top front isometric view of the high pressure fluid conduit connector components and connector assembly;

FIG. 2 is a bottom rear isometric view of the high pressure fluid conduit connector components and connector assembly;

FIG. 3 is a front view of the high pressure fluid conduit connector components and connector assembly;

FIG. 4 is a rear view of the high pressure fluid conduit connector components and connector assembly;

FIG. 5 is a right side view of the high pressure fluid conduit connector components and connector assembly;

FIG. 6 is a left side view of the high pressure fluid conduit connector components and connector assembly;

FIG. 7 is a top view of the high pressure fluid conduit connector components and connector assembly;

FIG. 8 is a bottom view of high pressure fluid conduit connector components and connector assembly;

FIG. 9 is a top cross sectional view of the high pressure fluid conduit connector components and connector assembly, taken along line 9-9 in FIG. 1 and generally along the center of the high pressure fluid conduit connector components and connector assembly;

FIG. 10 is a top cross sectional view of the high pressure fluid conduit connector components and connector assembly, taken along the line 10-10 in FIG. 1 and generally below a center of the high pressure fluid conduit connector components and connector assembly;

FIG. 11 is a top front isometric exploded view of the high pressure fluid conduit connector components and connector assembly, with two fluid connector components disengaged from one another; and,

FIG. 12 is a bottom rear isometric exploded view of the high pressure fluid conduit connector components and connector assembly.

The broken line showing is included for the purpose of illustrating portions of the article and forms no part of the claimed design.

1 Claim, 10 Drawing Sheets

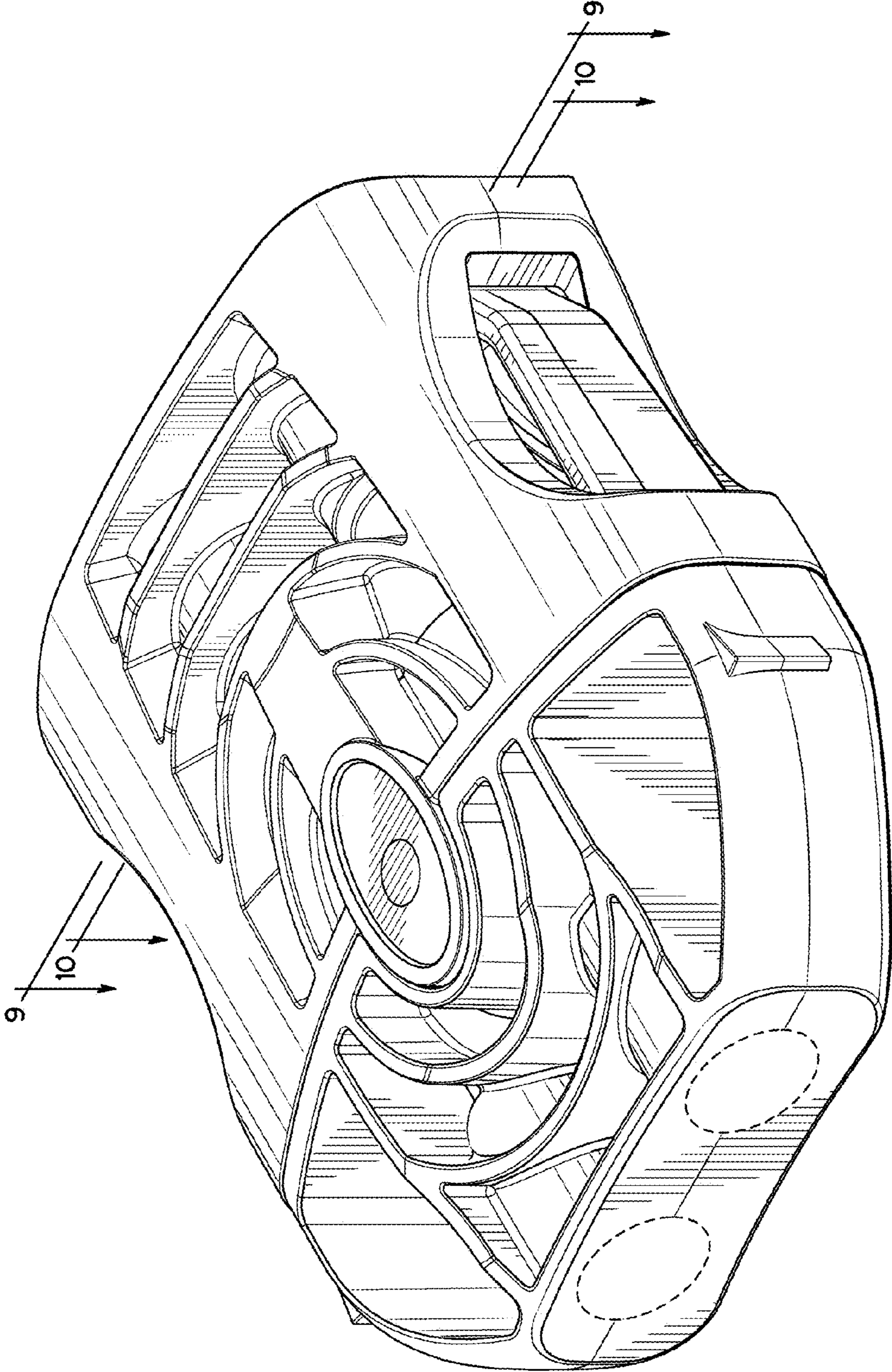

FIG. 1

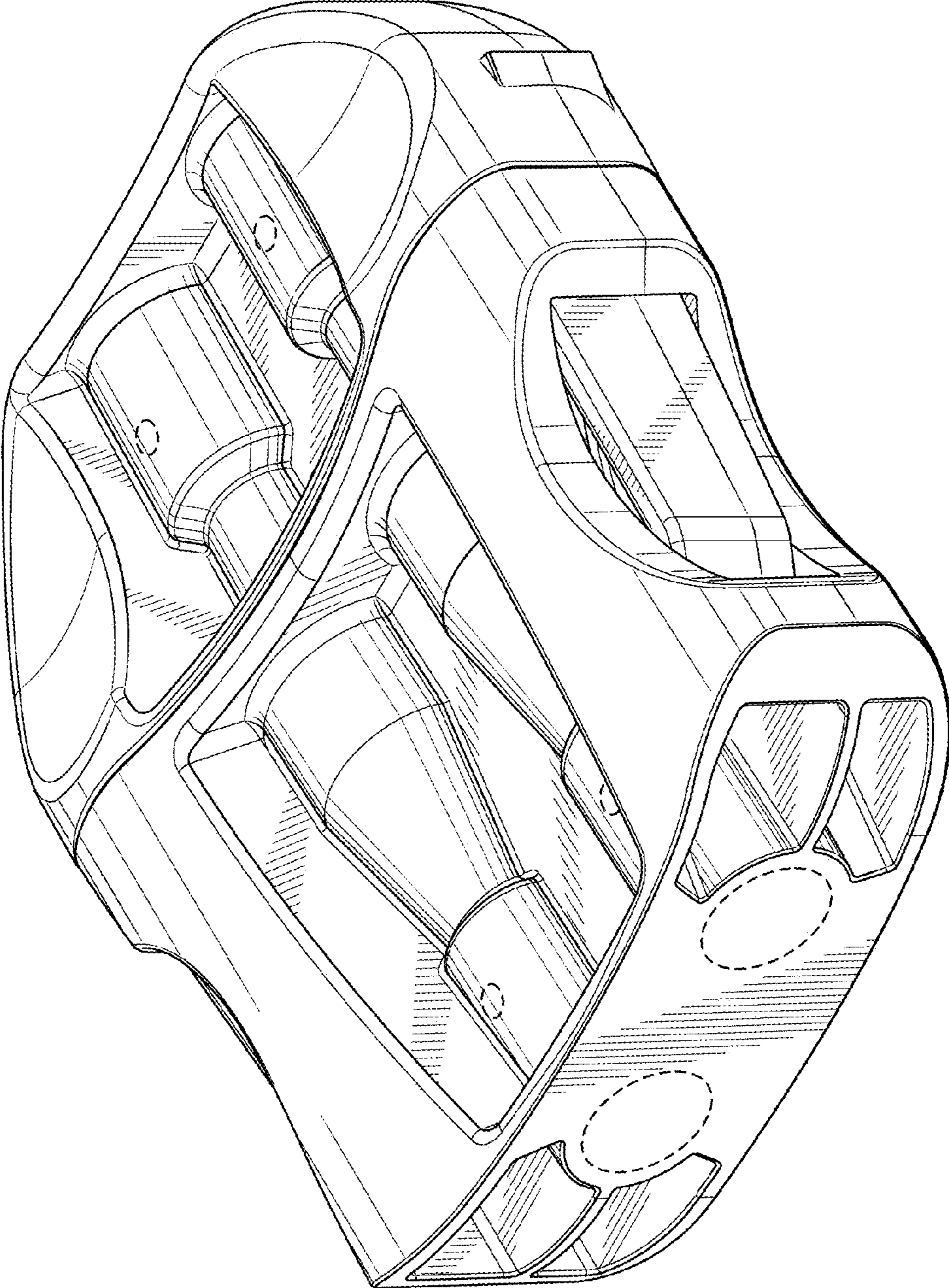

FIG. 2

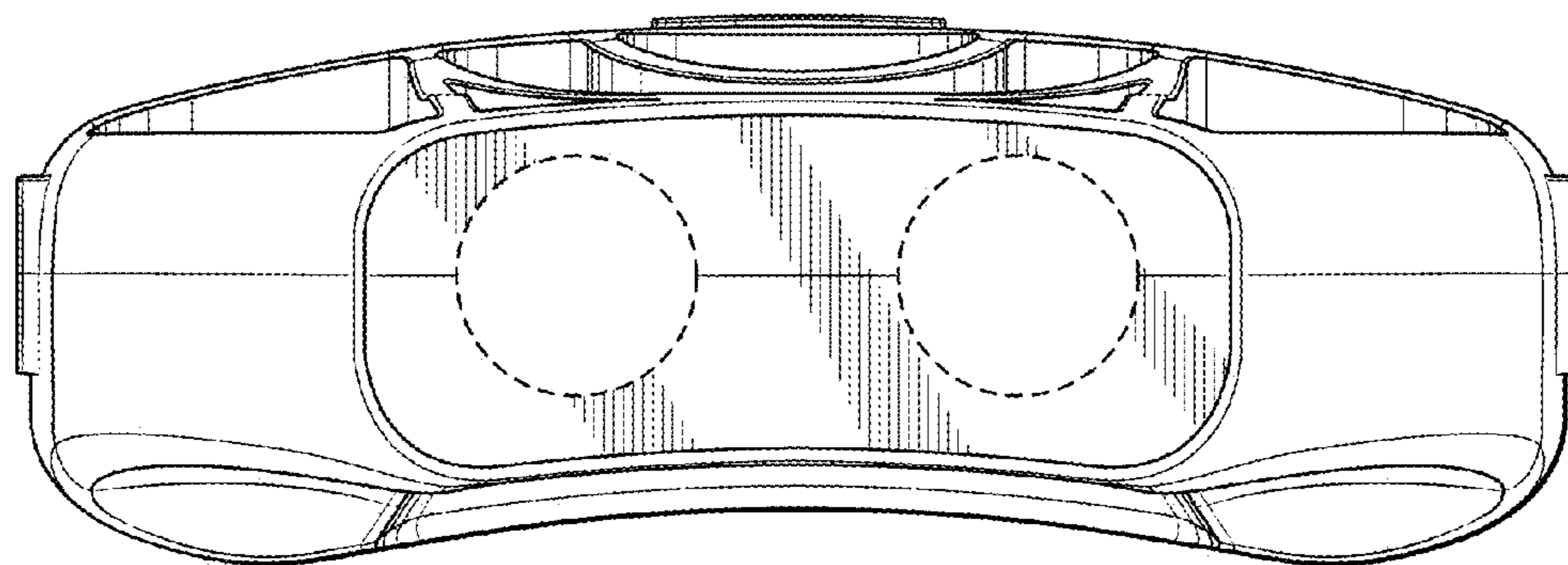

FIG. 3

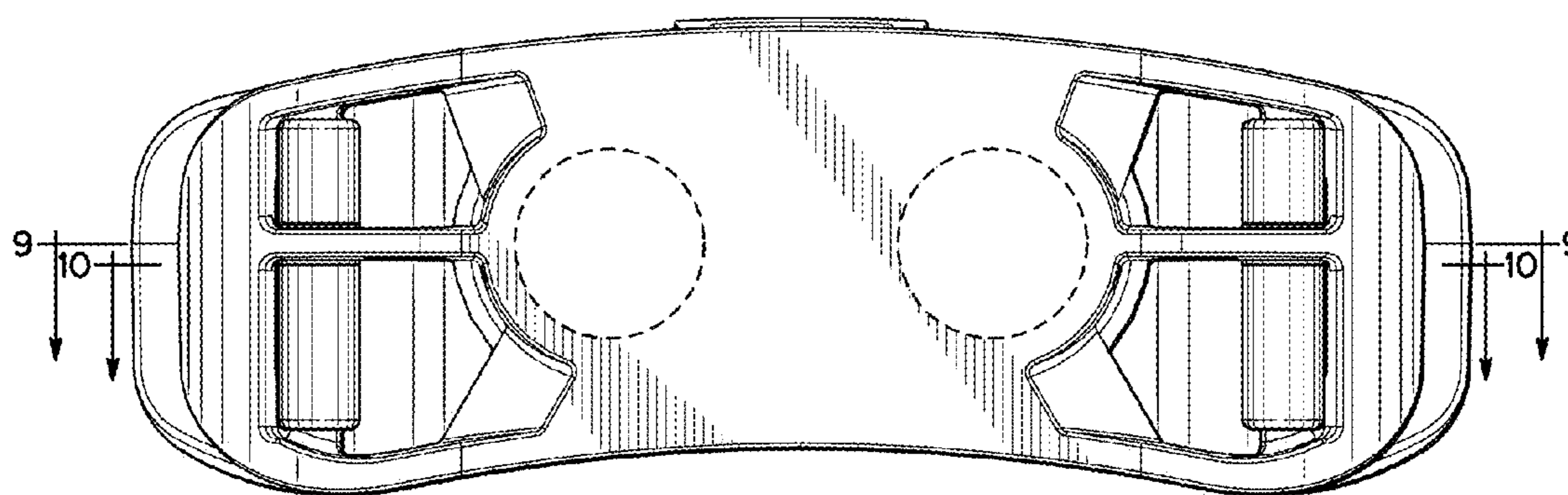

FIG. 4

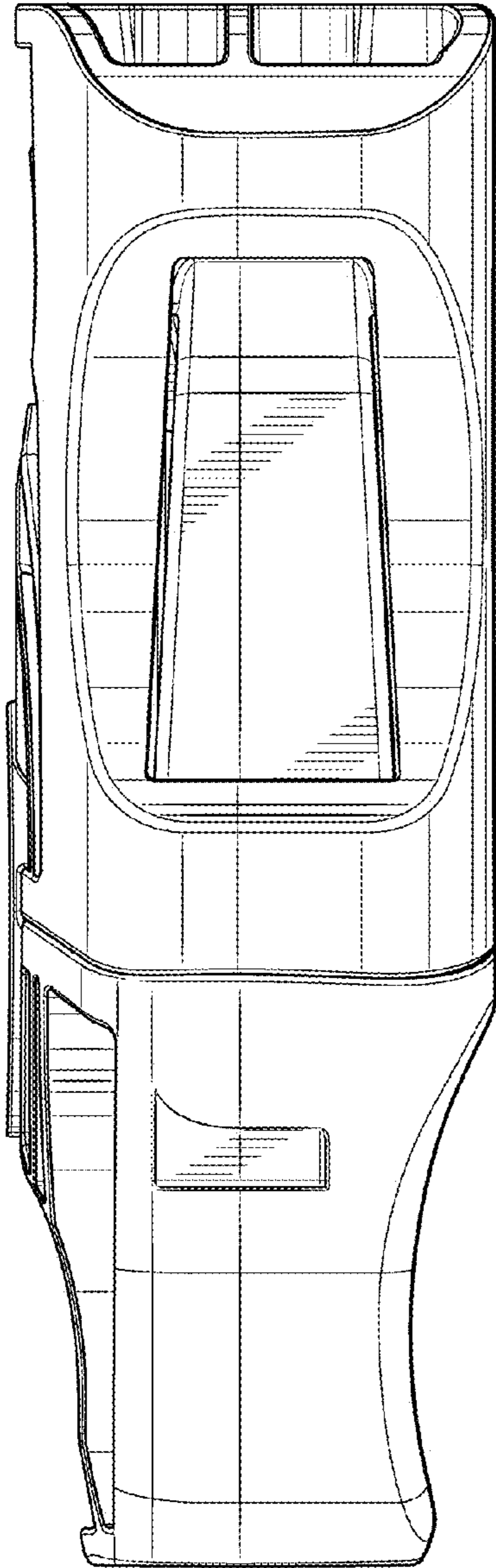

FIG. 5

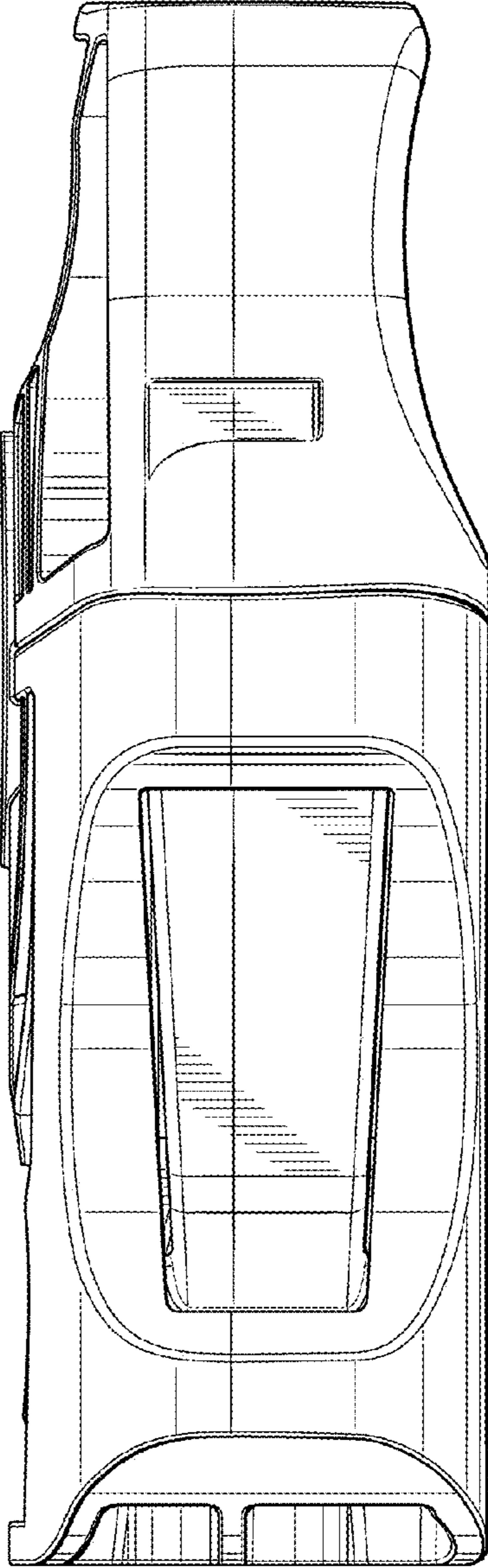

FIG. 6

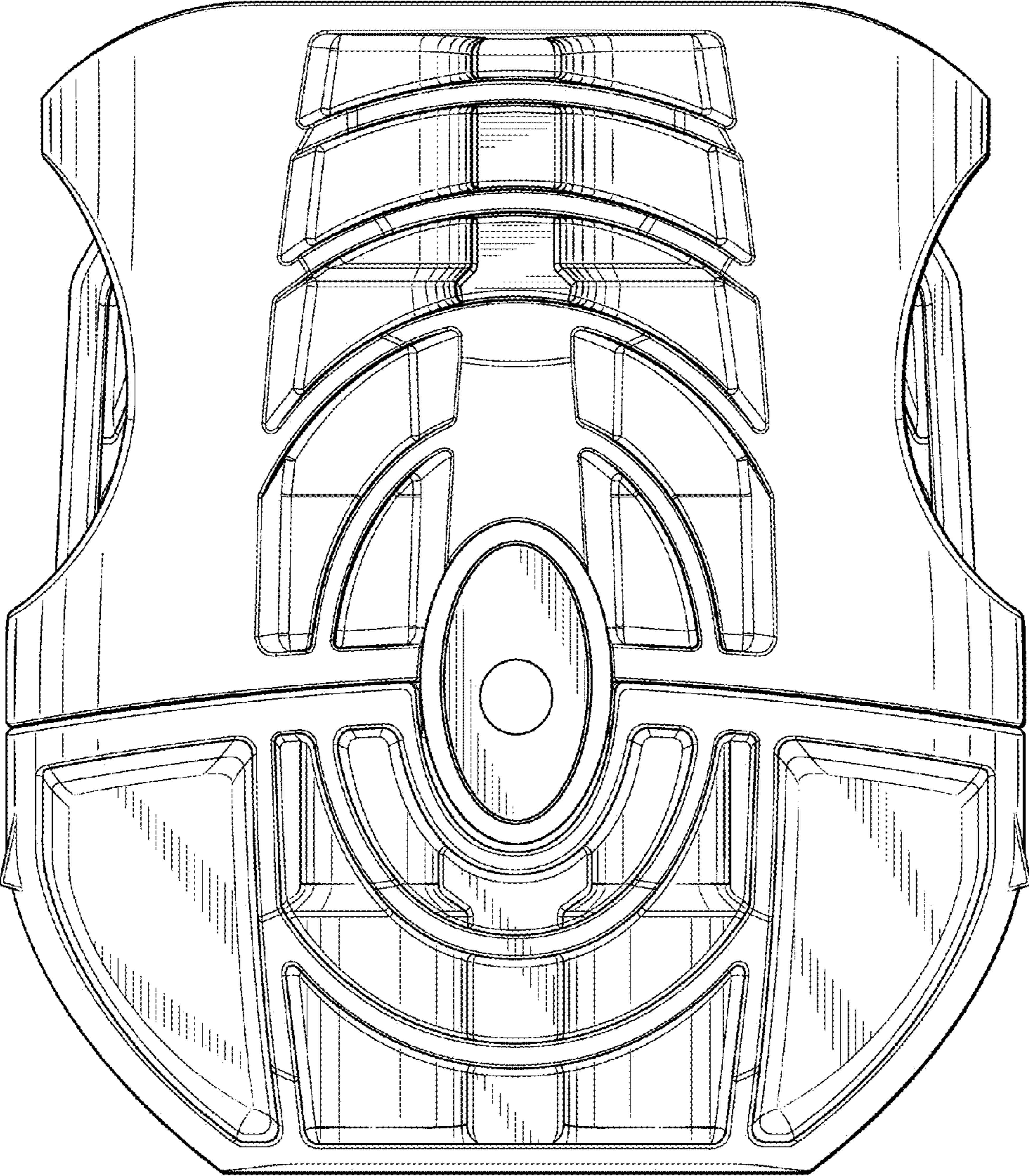

FIG. 7

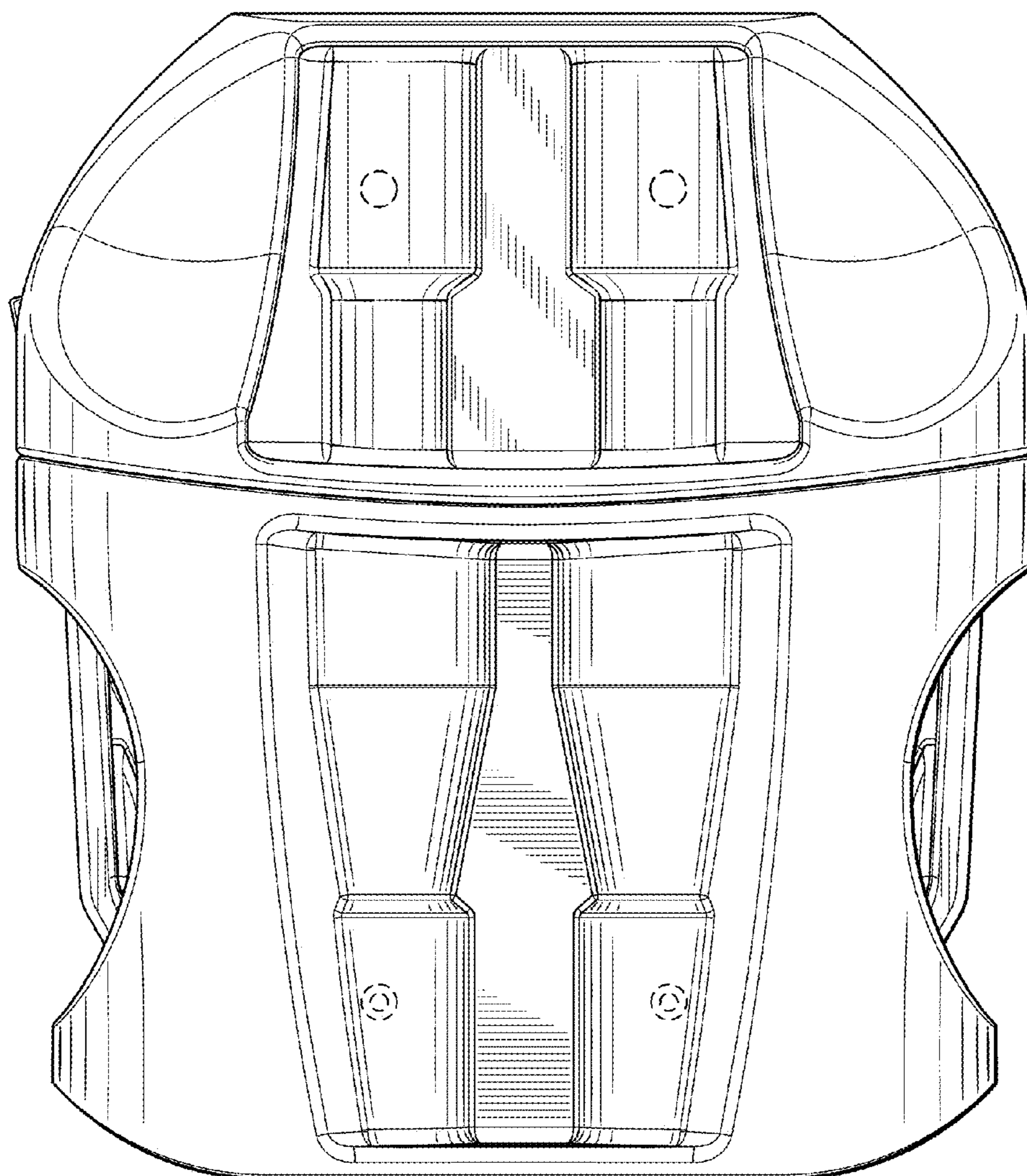

FIG. 8

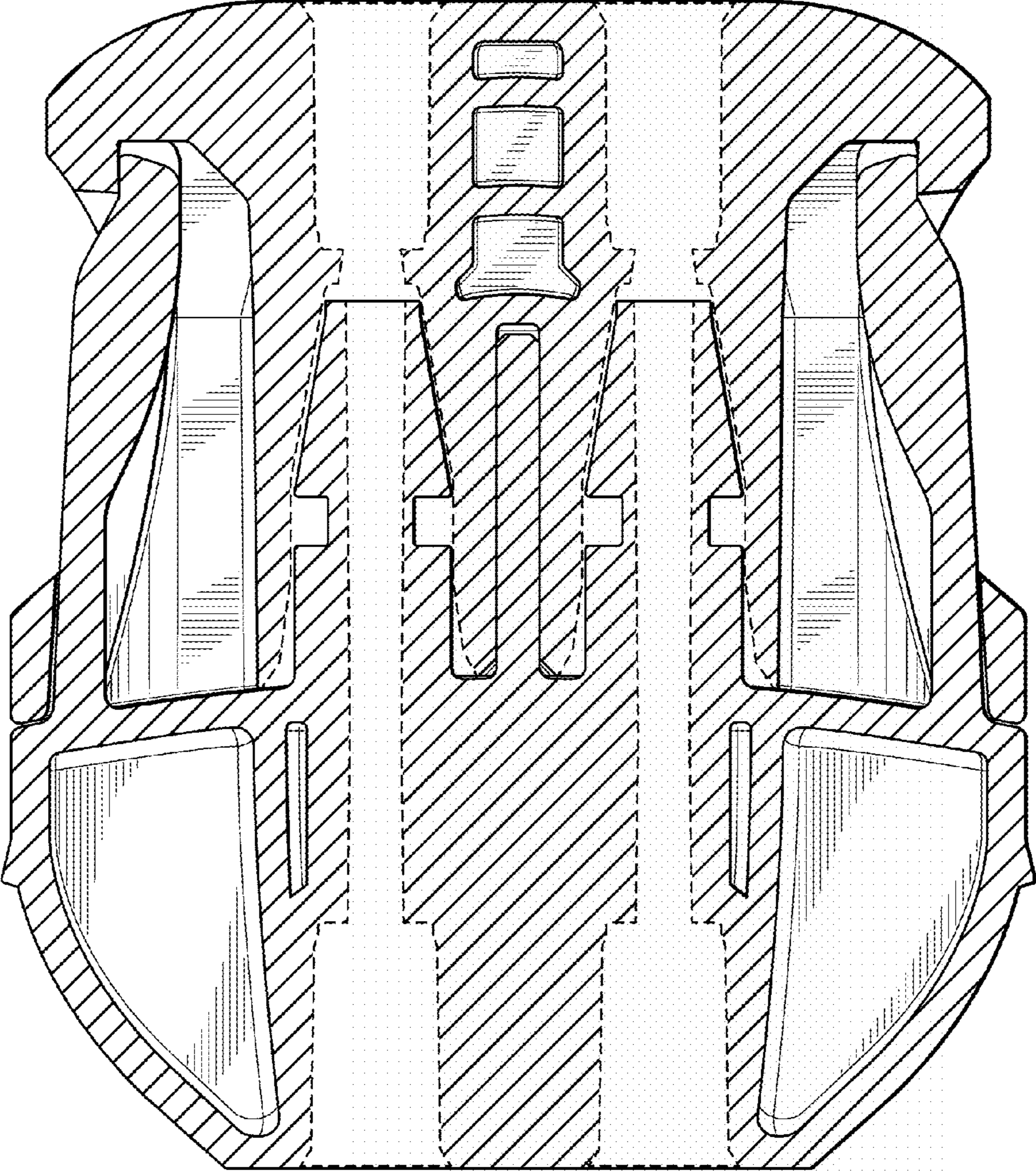

FIG. 9

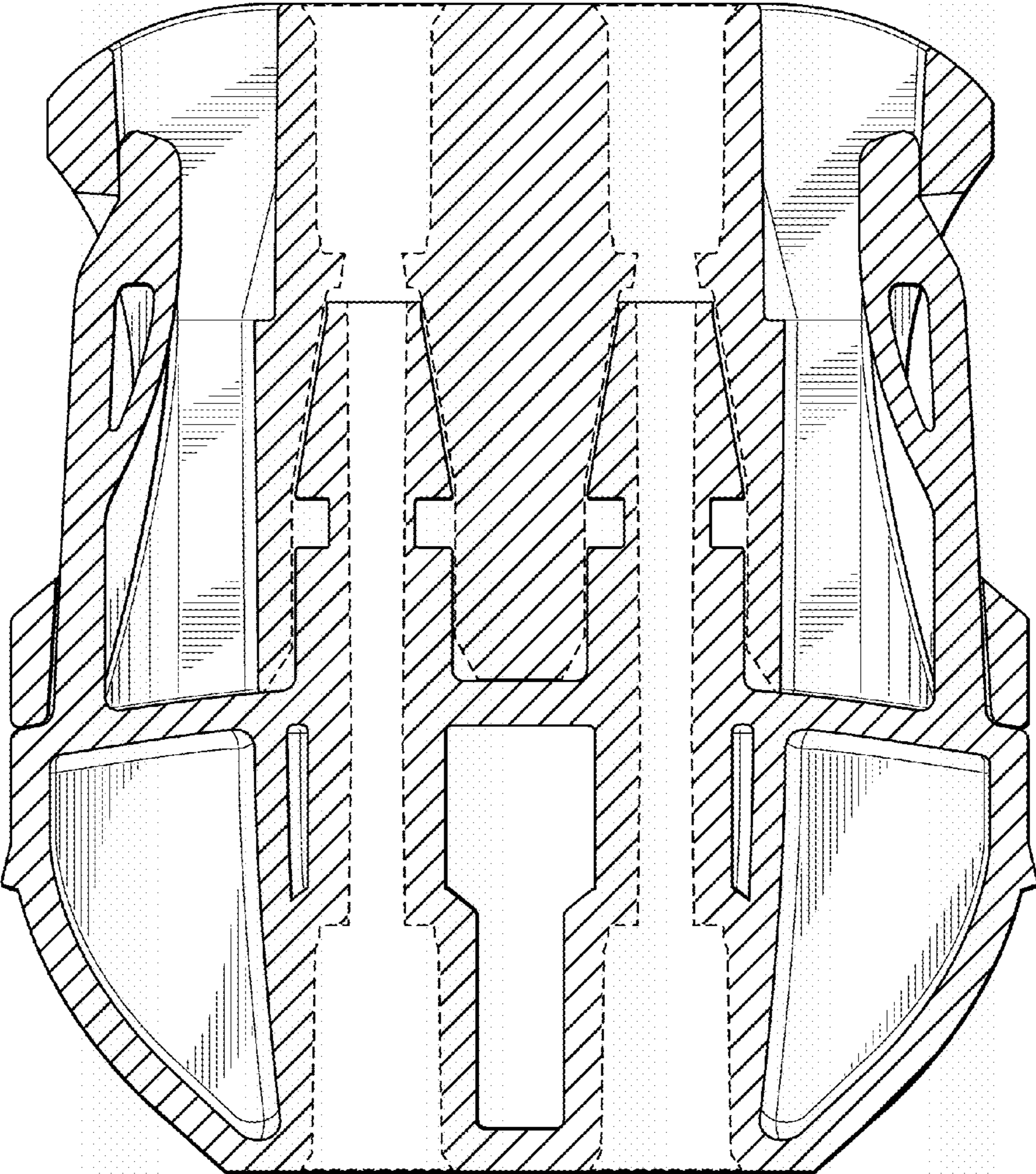

FIG. 10

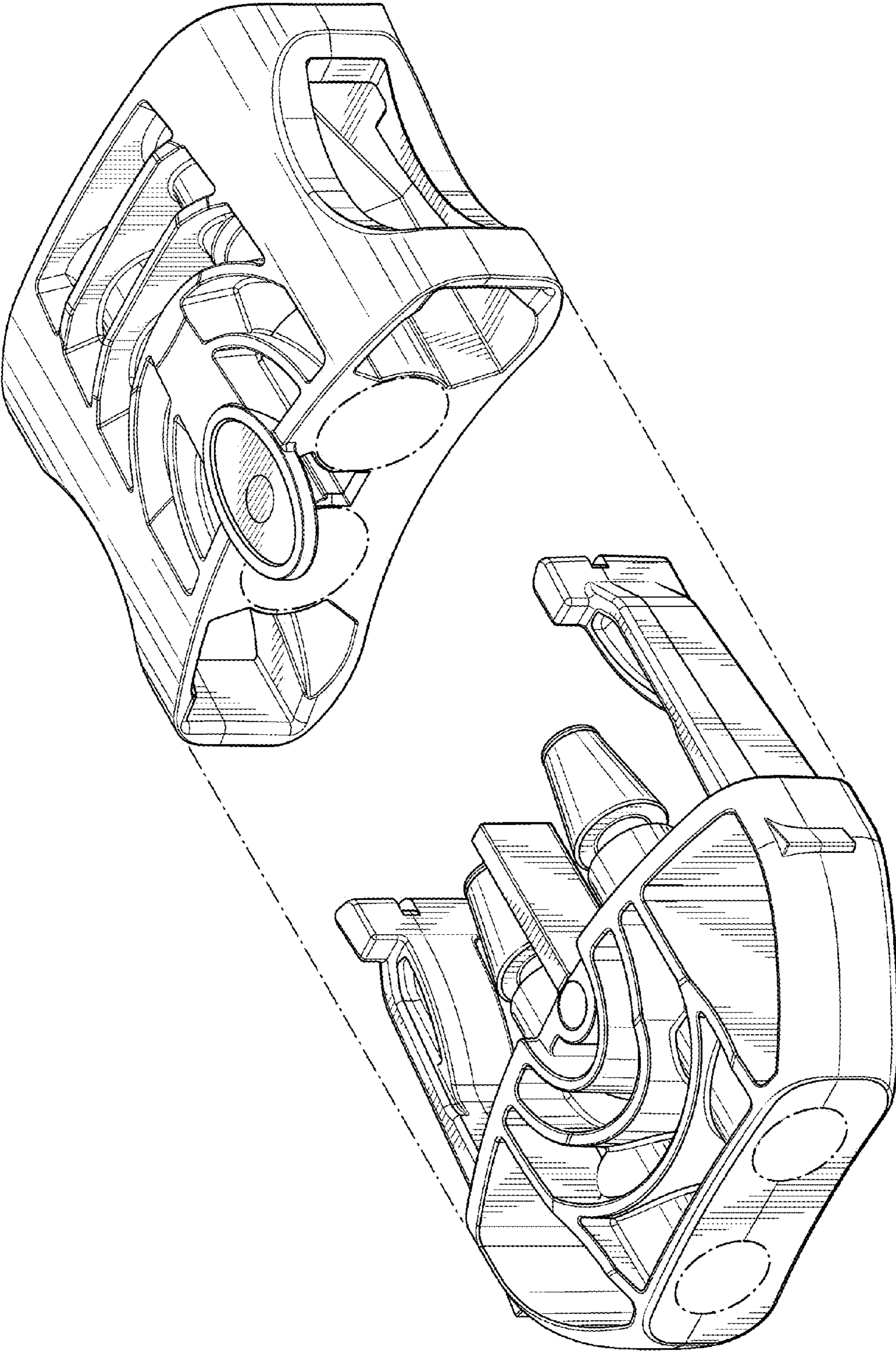

FIG. 11

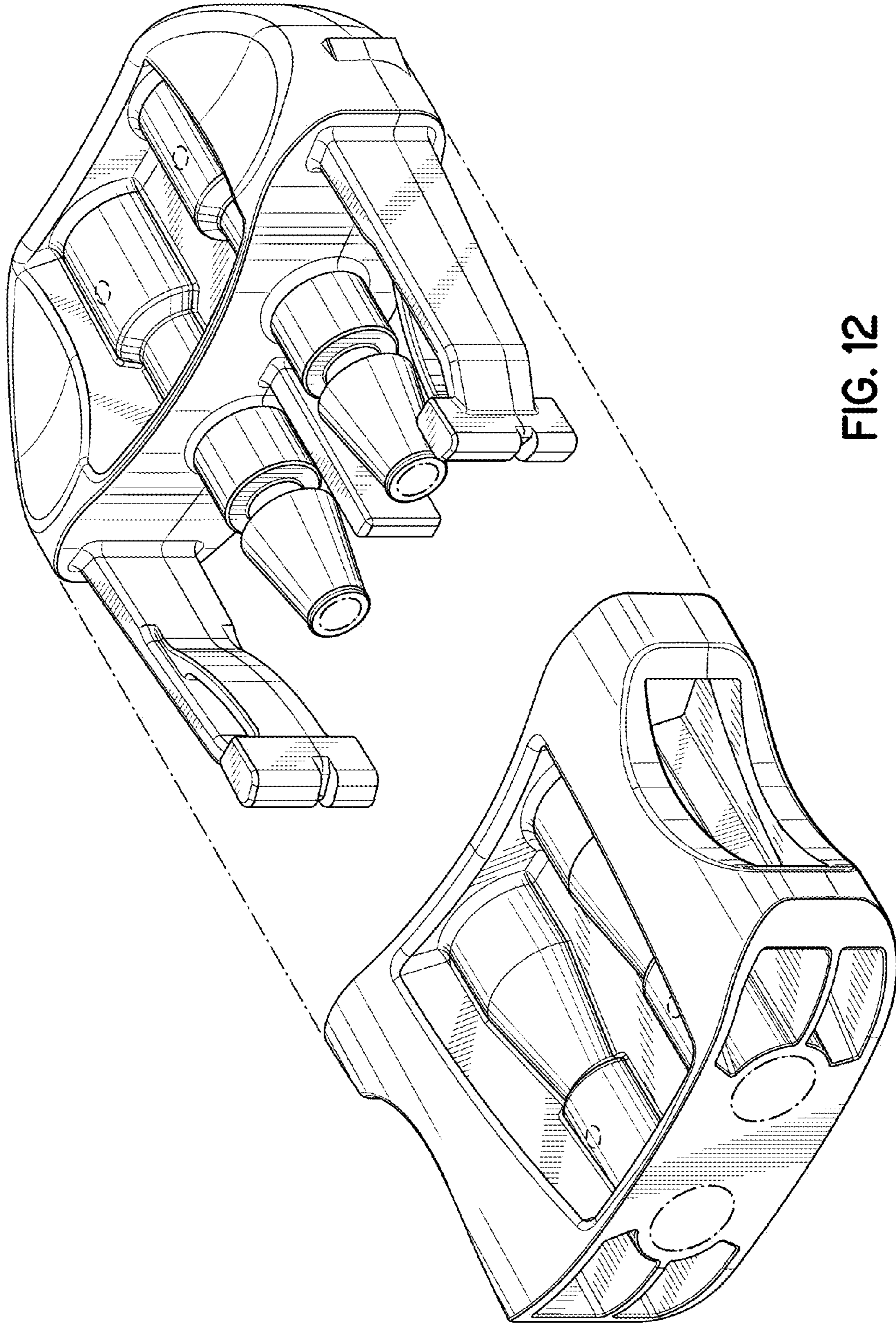

FIG. 12