



US00D742931S

(12) **United States Design Patent**  
**Burns, Jr. et al.**

(10) **Patent No.:** **US D742,931 S**

(45) **Date of Patent:** **\*\* Nov. 10, 2015**

(54) **SIDE TAPERED PANEL**

(71) Applicant: **Husqvarna AB**, Huskvarna (SE)

(72) Inventors: **Duncan K. Burns, Jr.**, Charlotte, NC (US); **Eric Tse**, Charlotte, NC (US); **Jerry Sandy**, Fort Mill, SC (US); **Sean Dwyer**, Gastonia, NC (US)

(73) Assignee: **HUSQVARNA AB**, Huskvarna (SE)

(\*\*) Term: **14 Years**

(21) Appl. No.: **29/492,457**

(22) Filed: **May 30, 2014**

(51) **LOC (10) Cl.** ..... **15-03**

(52) **U.S. Cl.**  
USPC ..... **D15/17**

(58) **Field of Classification Search**  
USPC ..... D15/10, 14-17, 22, 28, 33; 56/12.1, 56/12.7, 12.8, 13.4, 13.7, 16.7, 17.1, 17.5, 56/202, 255, 320.1-320.2; 180/89.1, 311  
CPC .... Y10S 56/22; A01D 2101/00; A01D 34/63; A01D 34/64; A01D 34/74; A01D 34/00  
See application file for complete search history.

(56) **References Cited**

U.S. PATENT DOCUMENTS

D344,960 S *	3/1994	Patterson et al.	.....	D15/17
D362,447 S *	9/1995	Lamb	.....	D15/15
D392,981 S *	3/1998	Smith	.....	D15/15
D397,121 S *	8/1998	Smith	.....	D15/15
D447,491 S *	9/2001	Goebert et al.	.....	D15/17

D448,036 S *	9/2001	Goebert et al.	.....	D15/17
D495,718 S *	9/2004	Higashikawa	.....	D15/15
D512,444 S *	12/2005	Ayers et al.	.....	D15/15
D626,572 S *	11/2010	Moriguchi et al.	.....	D15/15
D656,965 S *	4/2012	Ortlund et al.	.....	D15/17
D674,409 S *	1/2013	Higashikawa	.....	D15/17
D681,685 S *	5/2013	Higashikawa	.....	D15/15
D681,687 S *	5/2013	Higashikawa	.....	D15/17
D681,688 S *	5/2013	Higashikawa	.....	D15/17
D693,852 S *	11/2013	Brazier et al.	.....	D15/17
D722,619 S *	2/2015	Phillips et al.	.....	D15/17

\* cited by examiner

*Primary Examiner* — Mark Goodwin

(74) *Attorney, Agent, or Firm* — Nelson Mullins Riley & Scarborough LLP

(57) **CLAIM**

The ornamental design for a side tapered panel, as shown and described.

**DESCRIPTION**

FIG. 1 is a perspective view of a side tapered panel showing our new design in use condition mounted to a lawn mower; FIG. 2 is a right side view thereof; FIG. 3 is a left side view thereof; FIG. 4 is a front view thereof; FIG. 5 is a rear view thereof; and, FIG. 6 is a top plan view thereof. The broken lines of FIGS. 1-6 are illustrative of the visible environmental structure of the side tapered panel and form no part of the claimed design.

**1 Claim, 6 Drawing Sheets**

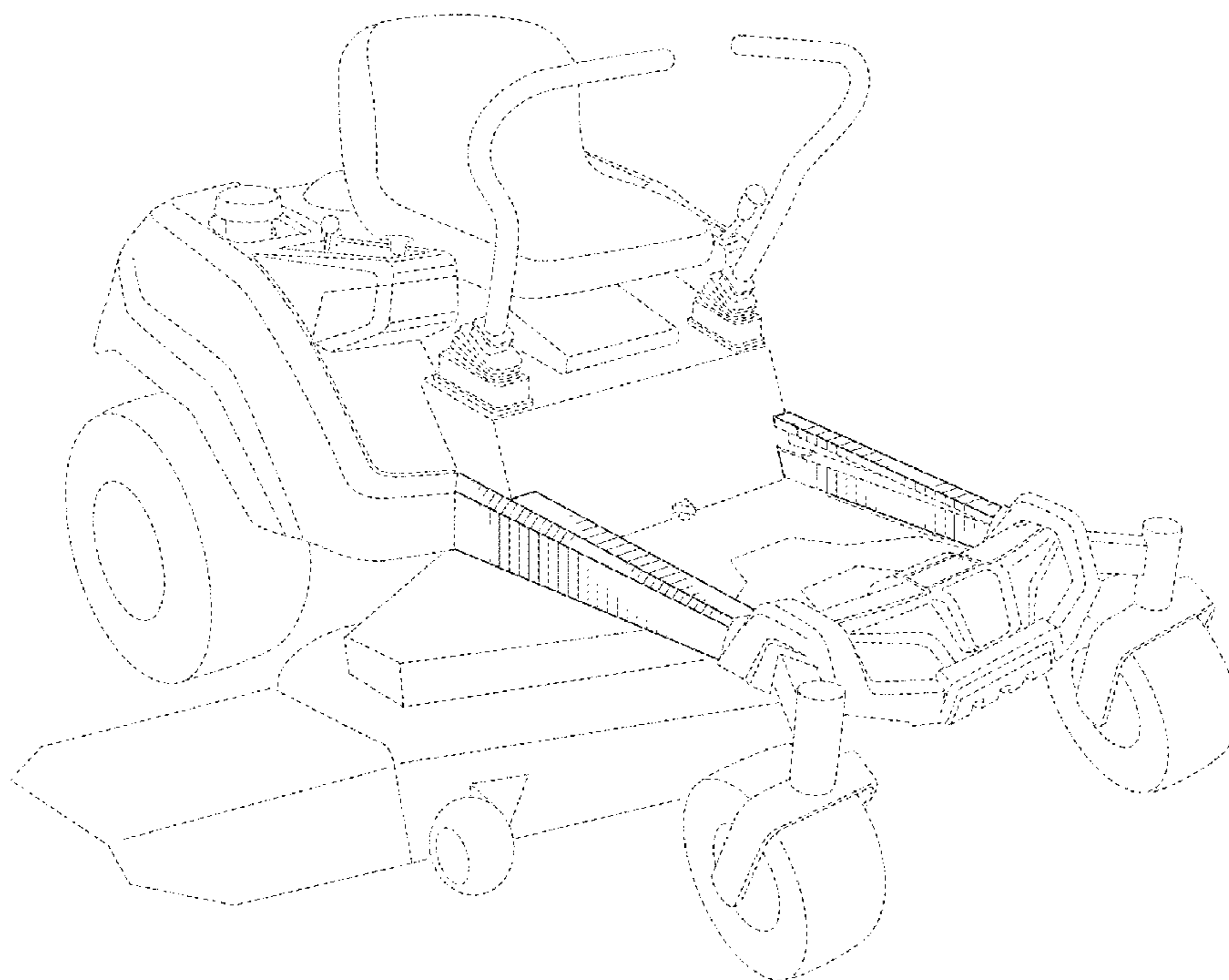

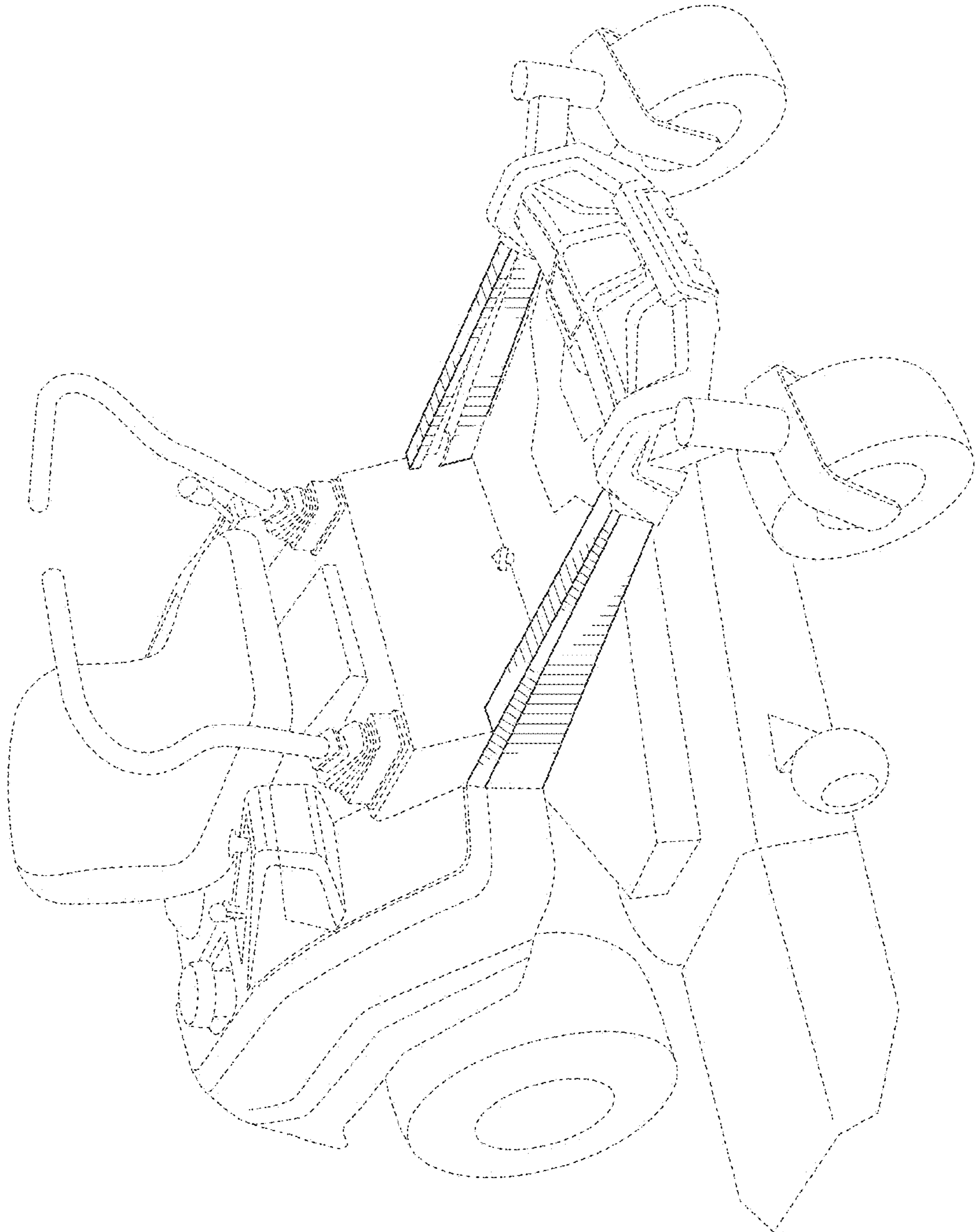

FIG. 1

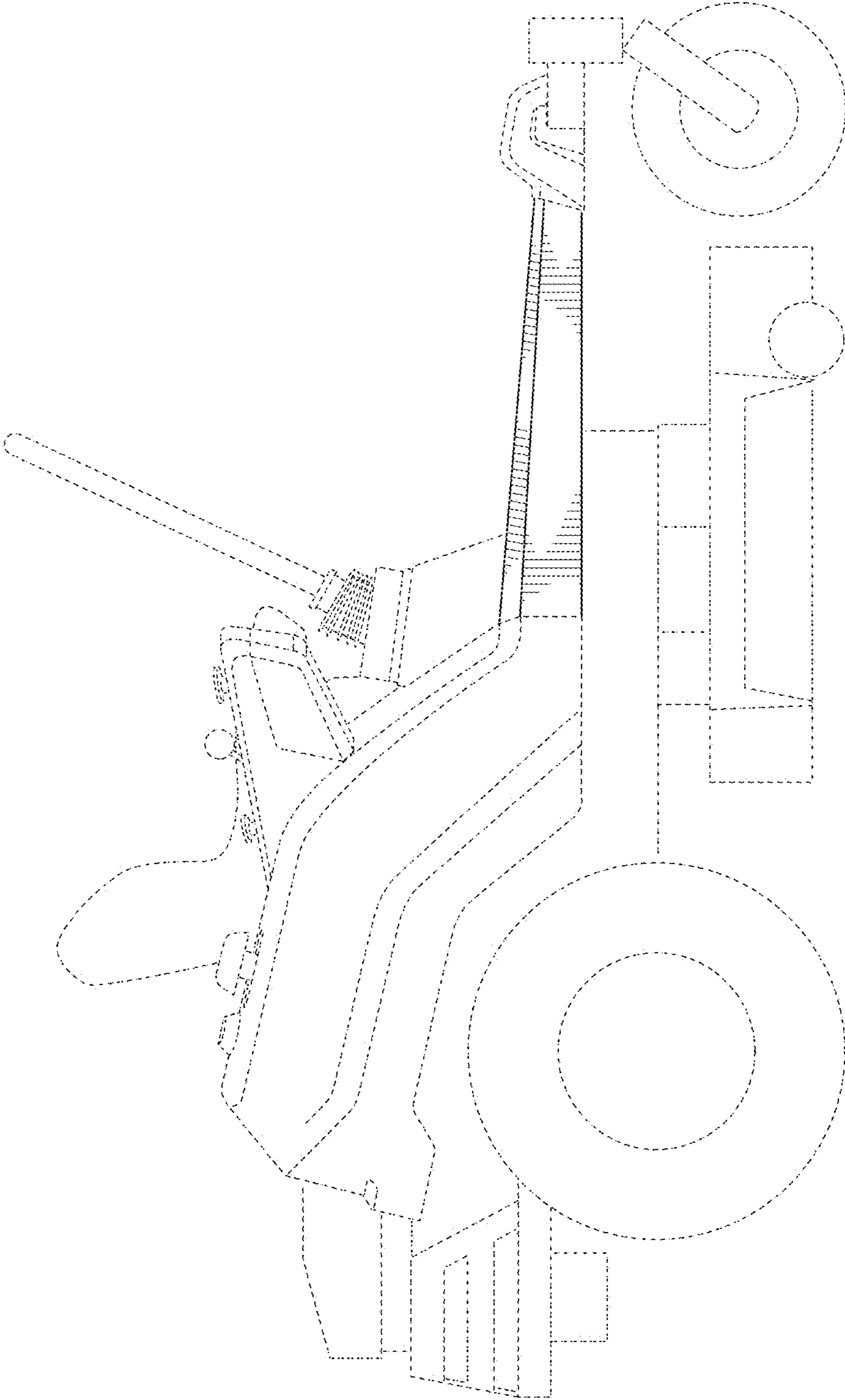

FIG. 2

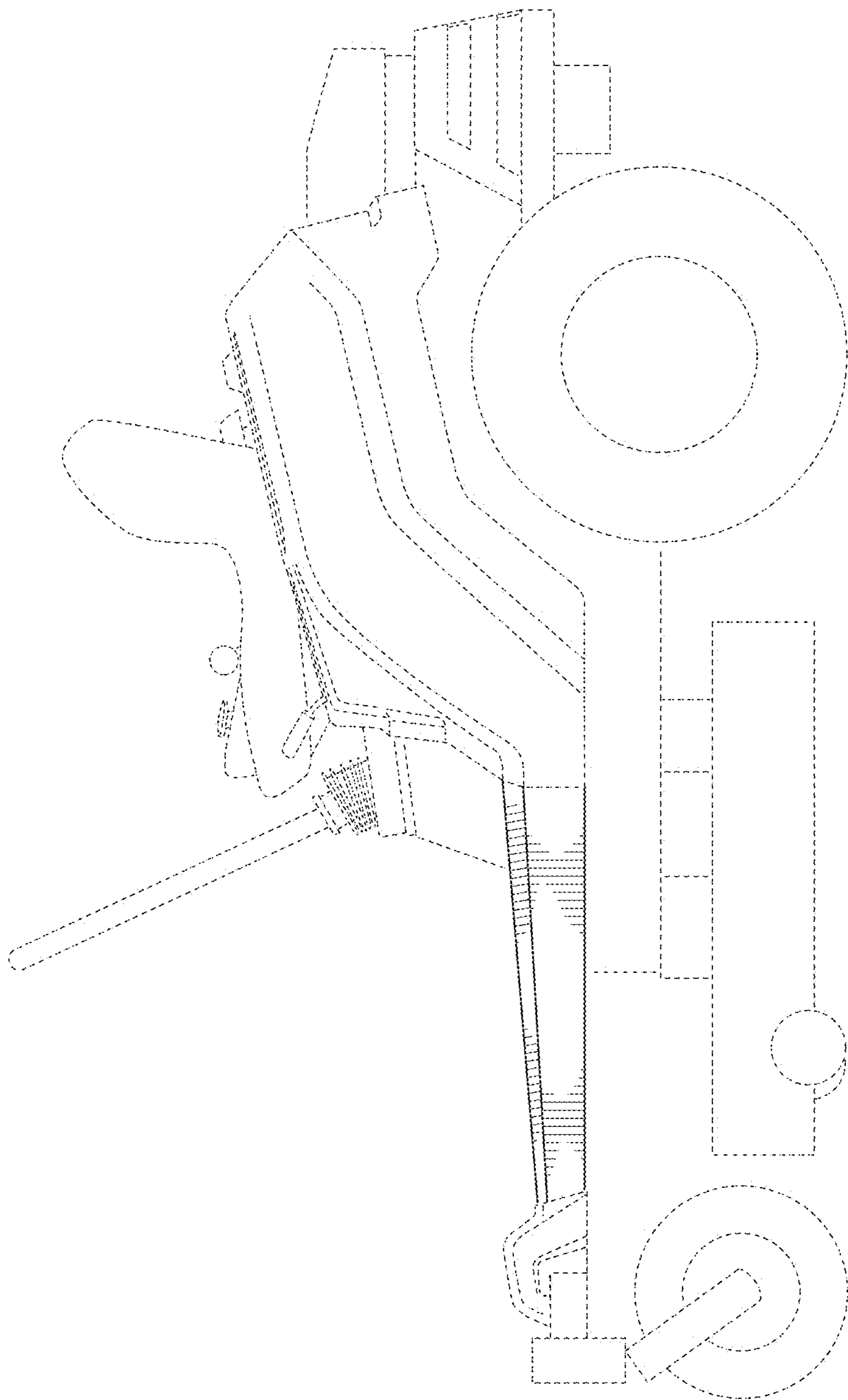

FIG. 3

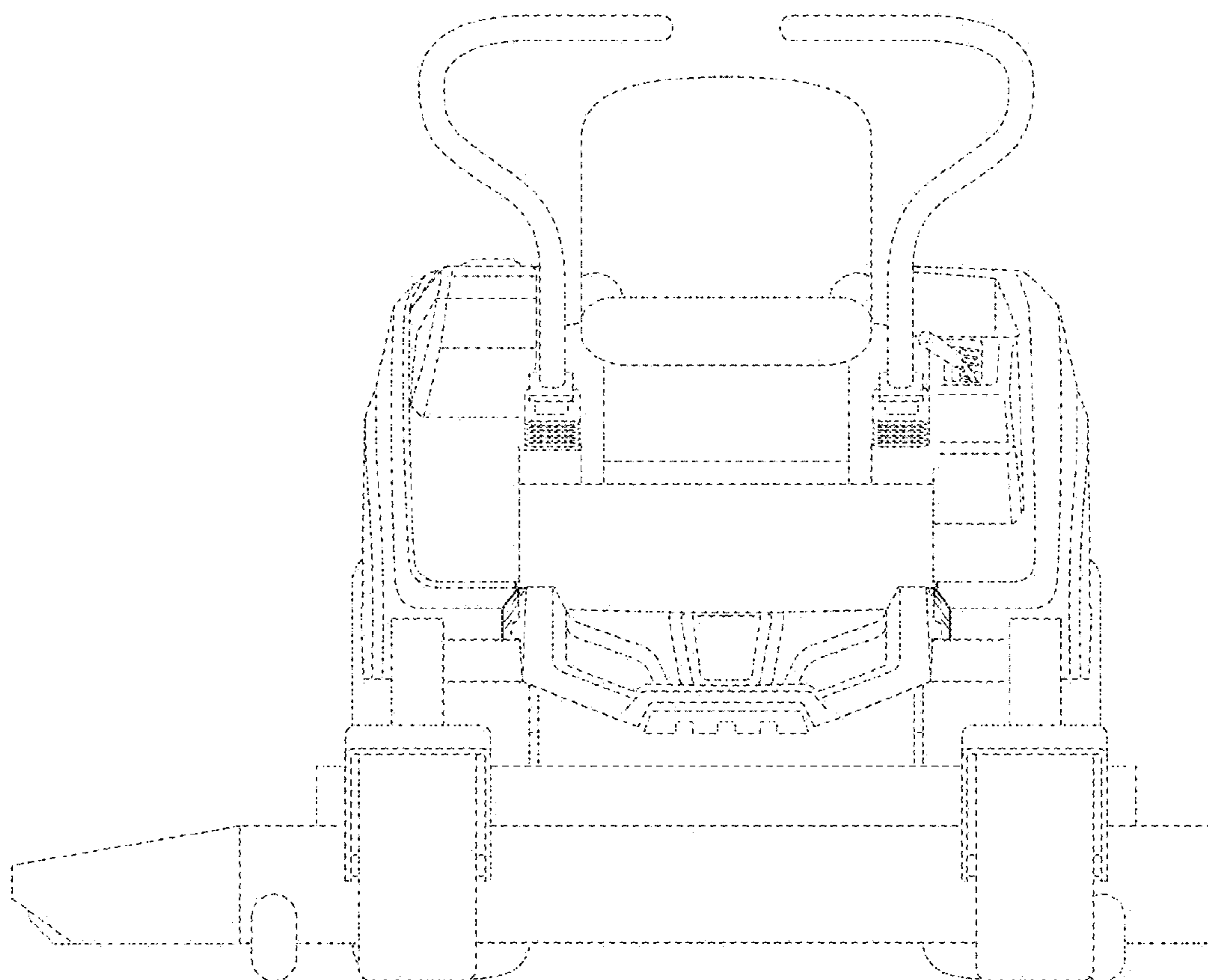

FIG. 4



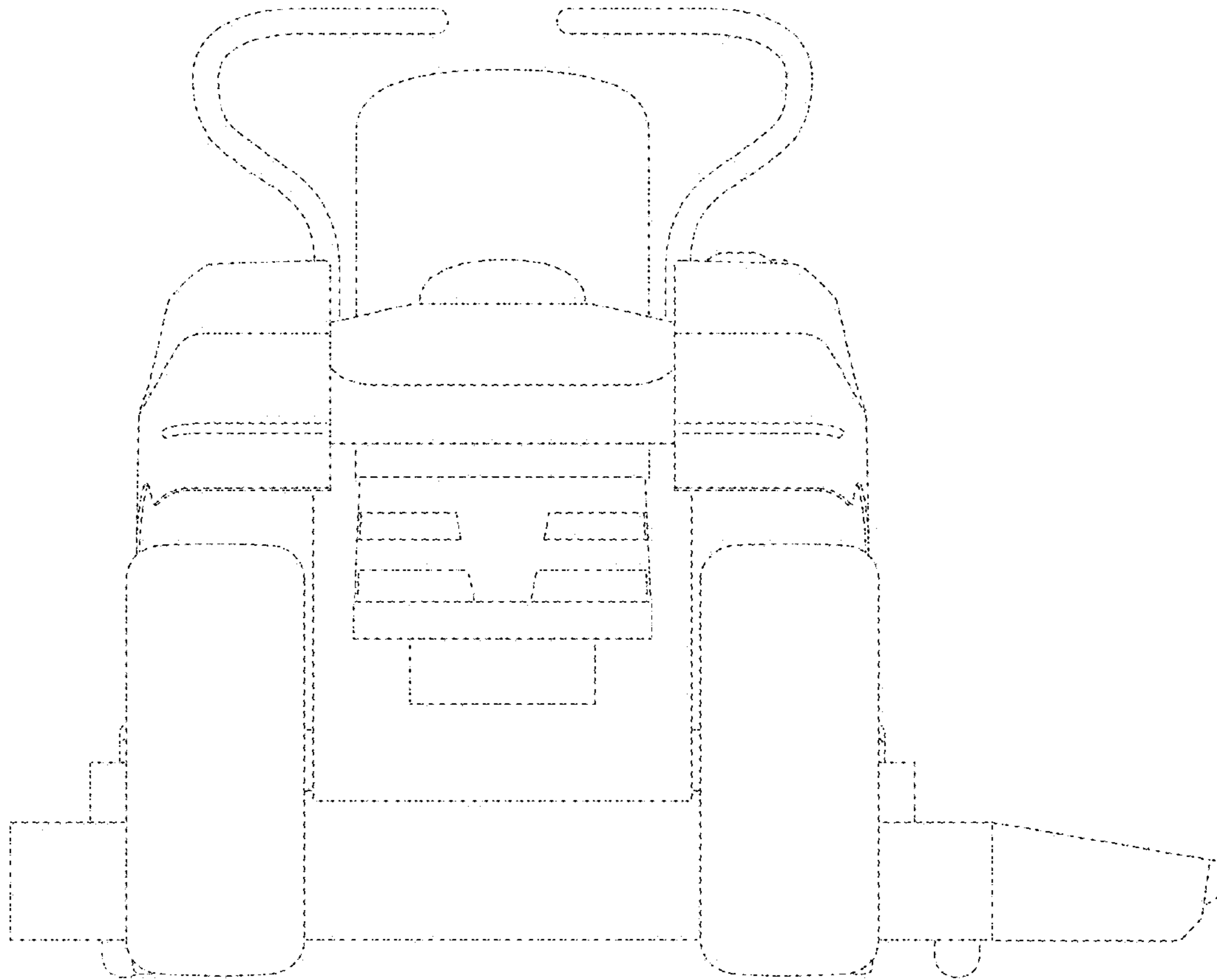

FIG. 5

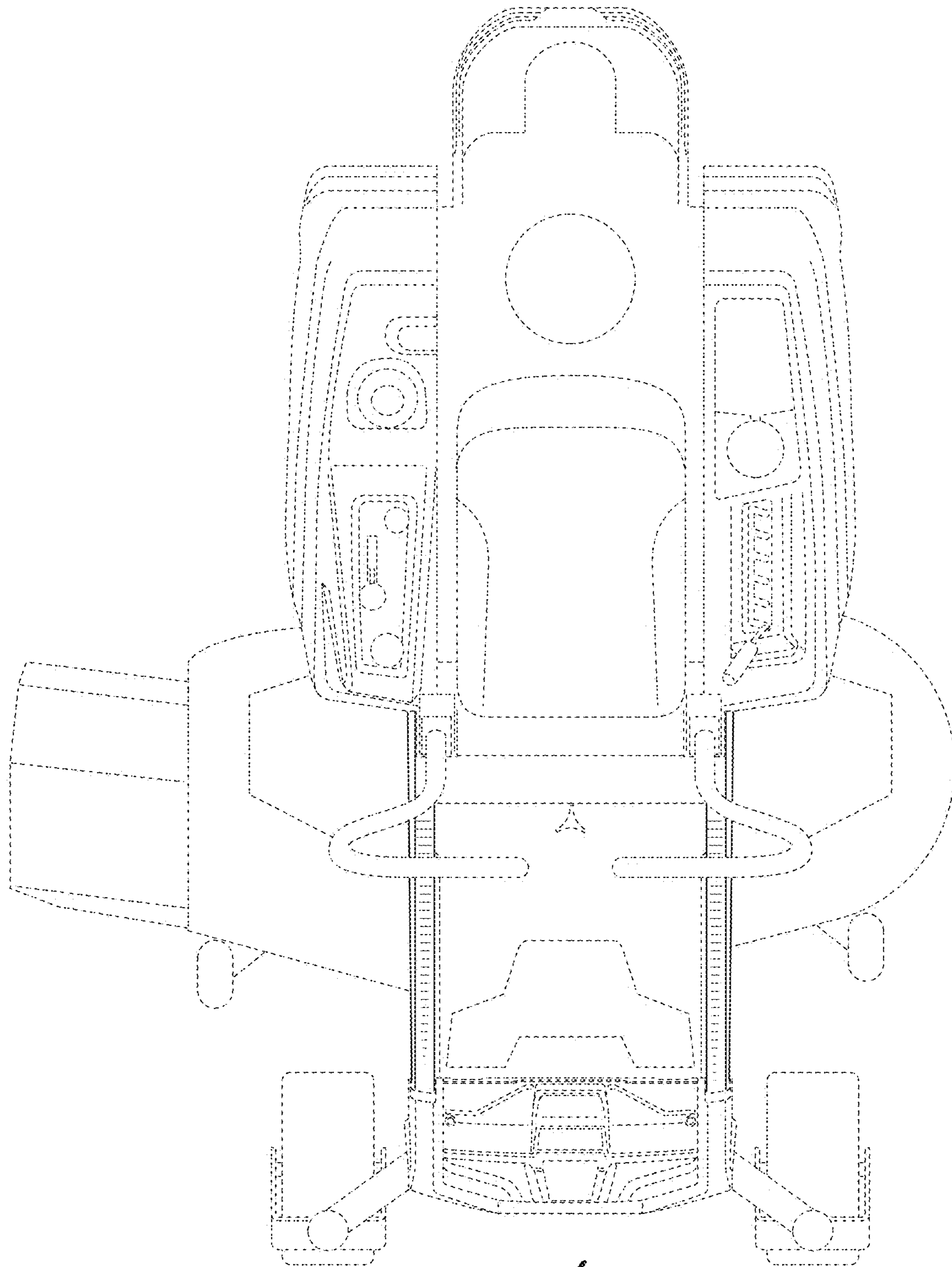

FIG. 6