



US00D742798S

(12) **United States Design Patent**
Wegener et al.

(10) **Patent No.:** **US D742,798 S**

(45) **Date of Patent:** **** *Nov. 10, 2015**

(54) **VEHICLE STEP**

2,066,964 A * 1/1937 Desagnat D25/158
2,900,495 A * 8/1959 Zwick D25/156
2,991,118 A * 7/1961 Sleger D12/203

(71) Applicant: **Ranch Hand Truck Accessories**, Shiner, TX (US)

(Continued)

(72) Inventors: **Darrin Wayne Wegener**, Shiner, TX (US); **Gregory Scott Chumchal**, Shiner, TX (US)

OTHER PUBLICATIONS

(73) Assignee: **Ranch Hand Truck Accessories**, Shiner, TX (US)

Frontier Truck Gear, <http://frontier-gear.com/products?clearparts=true&catid=1434>
&SuperTree=Exterior%20Accessories
&CatTree=Side%20Steps%20and%20Nerf%20Bars
&partypetree=Nerf/Step%20B, before May 20, 2014 (2 pages).

(*) Notice: This patent is subject to a terminal disclaimer.

Primary Examiner — George D Kirschbaum

Assistant Examiner — Natasha Vujcic

(74) *Attorney, Agent, or Firm* — Jackson Walker L.L.P.

(**) Term: **14 Years**

(57) **CLAIM**

(21) Appl. No.: **29/491,343**

The ornamental design for a vehicle step, as shown and described.

(22) Filed: **May 20, 2014**

DESCRIPTION

(51) **LOC (10) Cl.** **12-16**

FIG. 1 is a perspective view of a vehicle step illustrating the design.

(52) **U.S. Cl.**

FIG. 2 is a side view of the vehicle step of FIG. 1.

USPC **D12/203**

FIG. 3 is an opposite side view of the vehicle step of FIG. 1.

(58) **Field of Classification Search**

FIG. 4 is a front view of the vehicle step of FIG. 1.

USPC D12/89, 203, 314; 182/64.1, 127;
280/5.3, 163, 164.2, 166, 169, 291;
D6/567, 583, 585, 705, 705.7, 706;
D25/62, 63, 68, 69, 138, 152-157

FIG. 5 is a rear view of the vehicle step of FIG. 1.

CPC B60C 11/0008; B60C 11/0041; B60C 11/01;
B60C 11/12; E06C 1/005; E06C 1/02; E06C
5/00; E06C 5/02; E06C 5/04

FIG. 6 is a top view the vehicle step of FIG. 1.

See application file for complete search history.

FIG. 7 is bottom view of the vehicle step of FIG. 1.

FIG. 8 is a perspective view of a vehicle step similar to that in FIG. 1 in use on a pick-up truck; and,

FIG. 9 is a perspective view of a second embodiment of a vehicle step. Except for the break lines, the second embodiment is the same in appearance as the first embodiment.

The broken lines in the figures, which show a vehicle, represent the environment for use. The broken lines form no part of the claimed design. The break lines in FIG. 9 indicate that the appearance of any portion of the vehicle step between the break lines forms no part of the claimed design.

(56) **References Cited**

U.S. PATENT DOCUMENTS

D29,932 S * 1/1899 Hodge D25/153
D29,933 S * 1/1899 Hodge D25/153
D42,145 S * 2/1912 Morse D12/203

1 Claim, 5 Drawing Sheets

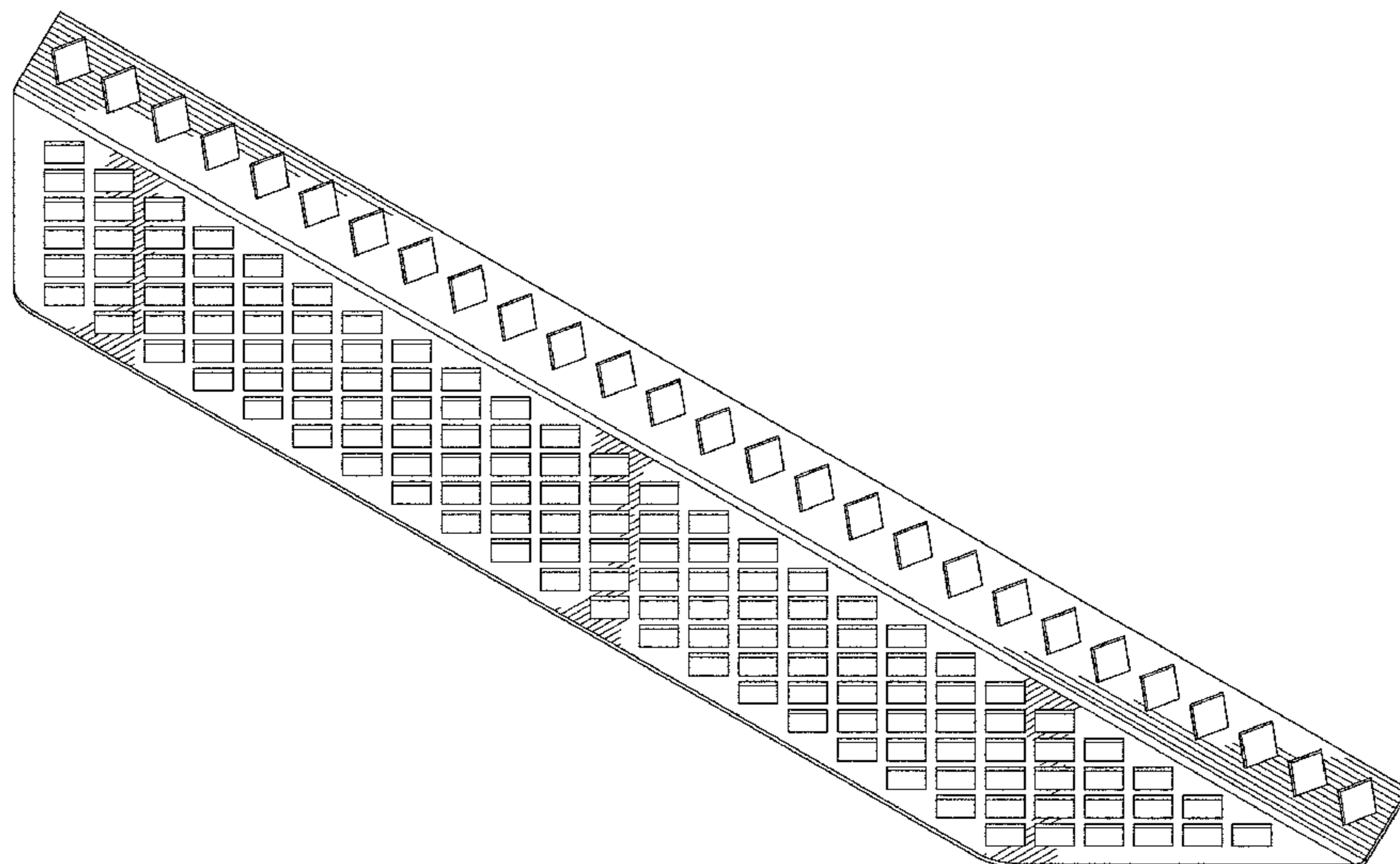

(56)

References Cited

U.S. PATENT DOCUMENTS

D213,043 S *	12/1968	Crepeau	D12/203	D549,145 S *	8/2007	Kieffer et al.	D12/203
D233,832 S *	12/1974	Becker	D25/156	D549,146 S *	8/2007	Kieffer et al.	D12/203
D297,387 S *	8/1988	Barr	D25/153	7,377,564 B1 *	5/2008	Baffy et al.	293/117
D329,157 S *	9/1992	Santucci	D6/511	D594,564 S *	6/2009	Disch et al.	D25/69
5,501,475 A *	3/1996	Bundy	280/166	D622,421 S *	8/2010	Akkala	D25/152
D395,268 S *	6/1998	Tucker	D12/203	D634,570 S *	3/2011	Lin	D6/511
D440,931 S *	4/2001	Knight et al.	D12/203	D634,957 S *	3/2011	Rosenzweig	D6/567
D479,930 S *	9/2003	Cook et al.	D6/511	D640,490 S *	6/2011	Nevison	D6/585
D485,458 S *	1/2004	Govrik et al.	D6/511	D668,689 S *	10/2012	Bang	D12/203
D488,759 S *	4/2004	Hattori et al.	D12/203	D679,031 S *	3/2013	Amend	D25/163
				D688,818 S *	8/2013	Martelli	D25/155
				2011/0266766 A1 *	11/2011	Huang-Tsai	280/169

* cited by examiner

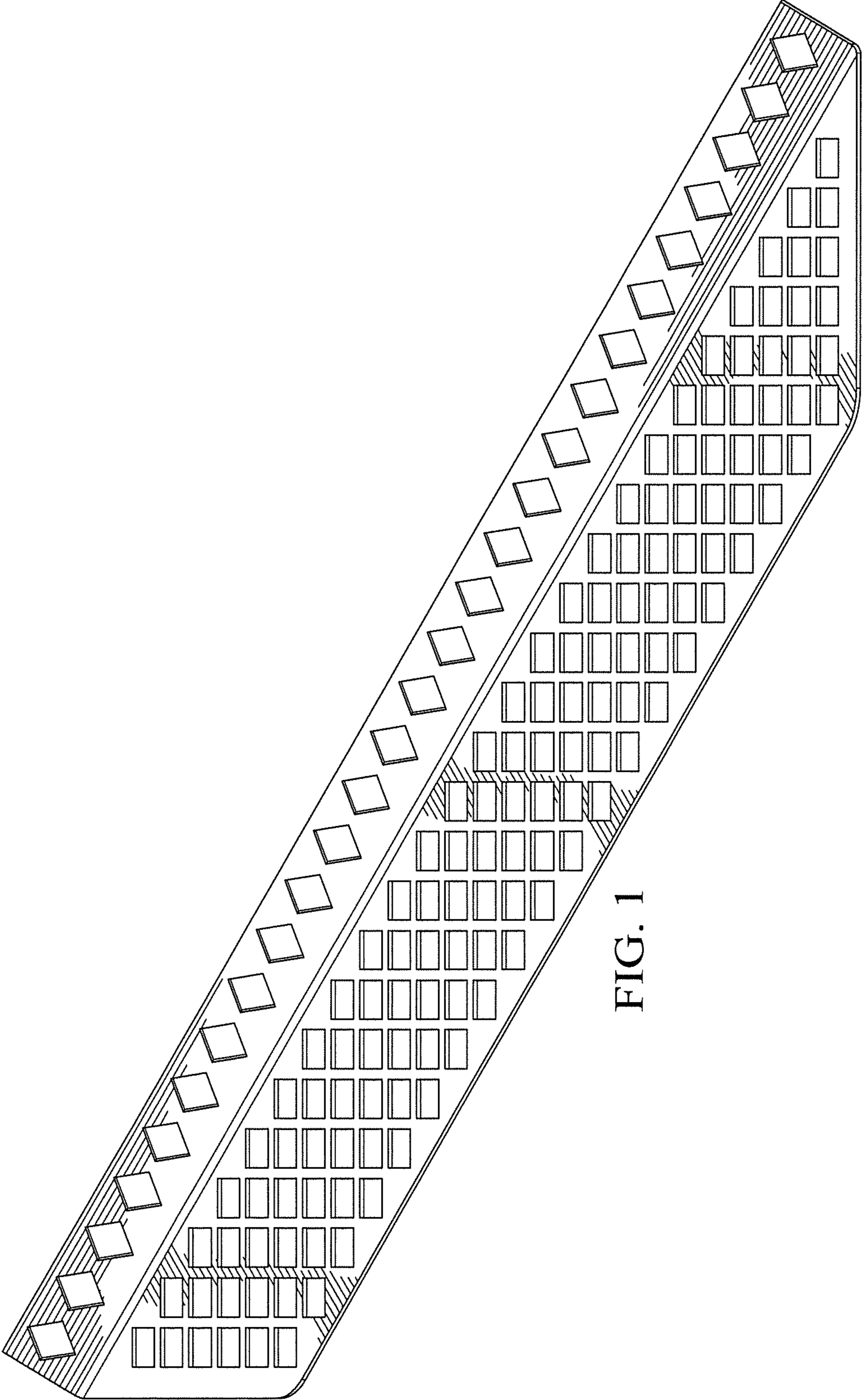

FIG. 1



FIG. 2



FIG. 3



FIG. 4



FIG. 5

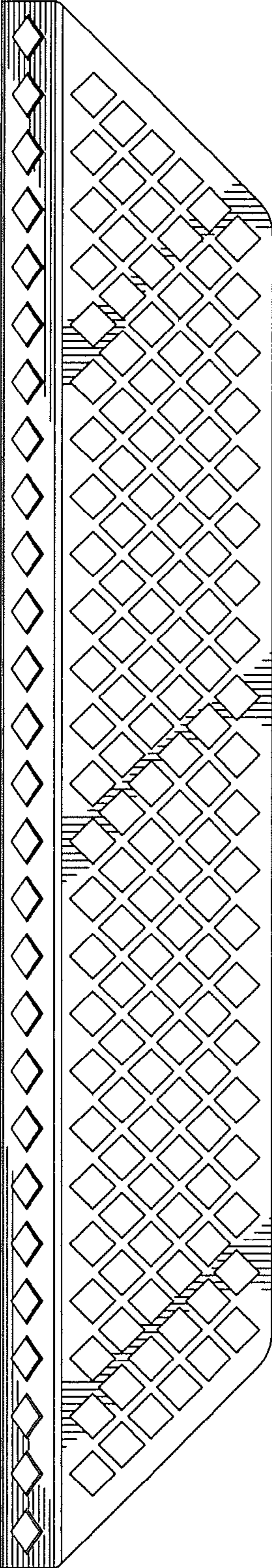

FIG. 6

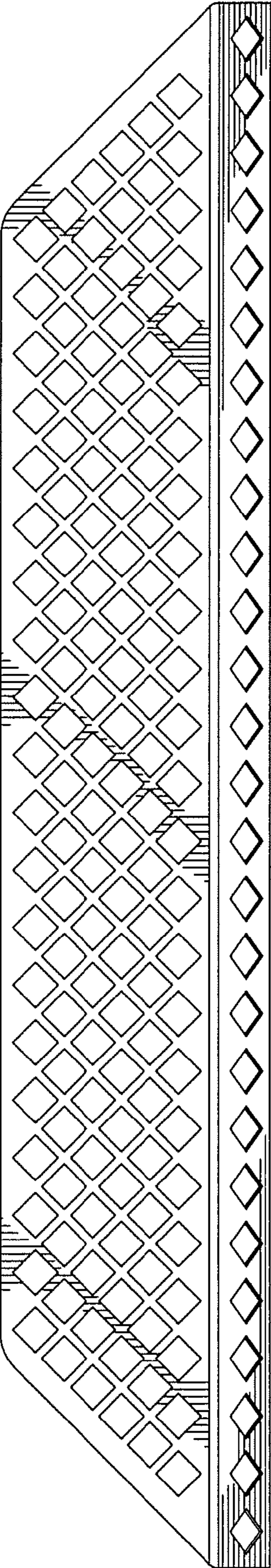

FIG. 7

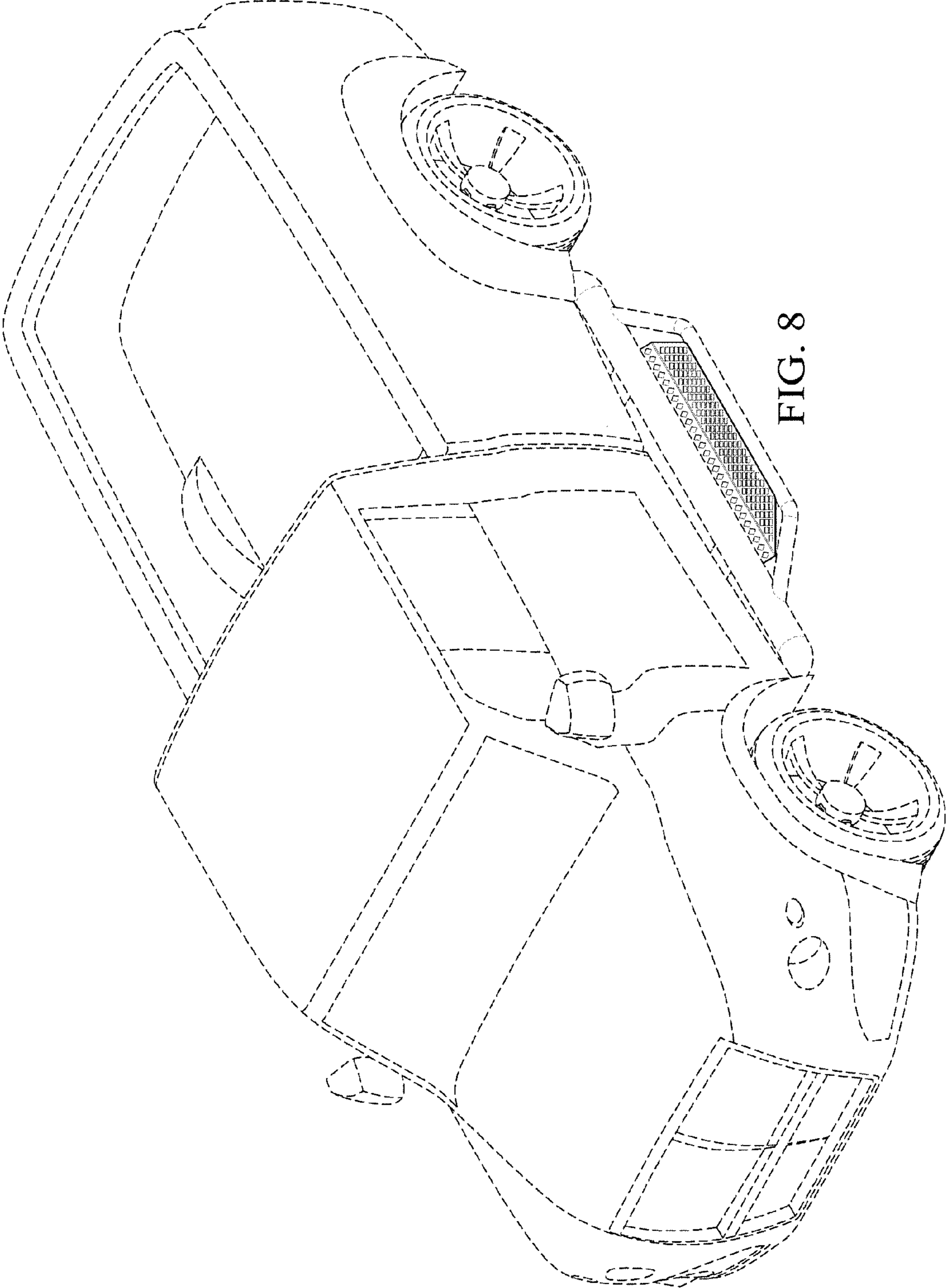

FIG. 8

