



US00D742510S

(12) **United States Design Patent**  
**Wagner**

(10) **Patent No.:** **US D742,510 S**  
(45) **Date of Patent:** **\*\* Nov. 3, 2015**

- (54) **GRIPPING TONGS**
- (71) Applicant: **Sebastian Wagner**, Bretten (DE)
- (72) Inventor: **Sebastian Wagner**, Bretten (DE)
- (73) Assignee: **Karl Storz GmbH & Co. KG** (DE)
- (\*\*) Term: **14 Years**
- (21) Appl. No.: **29/477,381**
- (22) Filed: **Dec. 20, 2013**
- (30) **Foreign Application Priority Data**
- Jun. 20, 2013 (EM) ..... 002258962-0002
- (51) **LOC (10) Cl.** ..... **24-02**
- (52) **U.S. Cl.**
- USPC ..... **D24/133**
- (58) **Field of Classification Search**
- USPC ..... D24/133, 153, 143-148, 152; D8/51,  
D8/52, 54; D19/73; D7/686; D15/28;  
606/45, 51, 41, 1, 46, 40, 167, 174,  
606/205, 206, 207, 277, 120, 147, 151, 324  
See application file for complete search history.

- (56) **References Cited**
- U.S. PATENT DOCUMENTS
- D255,715 S \* 7/1980 Markham ..... D24/143
- D268,523 S \* 4/1983 Scanlan et al. .... D24/143
- D276,461 S \* 11/1984 Scanlan et al. .... D24/143

- D287,630 S \* 1/1987 Sharkany et al. .... D24/145
- D632,788 S \* 2/2011 Thouement ..... D24/133
- D689,606 S \* 9/2013 John et al. .... D24/133
- D709,195 S \* 7/2014 Peck ..... D24/143
- D710,006 S \* 7/2014 John et al. .... D24/133
- D720,069 S \* 12/2014 Kaercher et al. .... D24/133
- 2009/0163920 A1 \* 6/2009 Hochschuler et al. .... 606/74
- 2011/0307011 A1 \* 12/2011 Moskowitz et al. .... 606/249
- 2014/0236170 A1 \* 8/2014 Kethman et al. .... 606/120
- 2014/0276917 A1 \* 9/2014 Trivisani ..... 606/120

\* cited by examiner

*Primary Examiner* — Garth Rademaker  
*Assistant Examiner* — Samantha Q Lawrence  
(74) *Attorney, Agent, or Firm* — Whitmyer IP Group LLC

(57) **CLAIM**  
The ornamental design for a gripping tongs, as shown and described.

**DESCRIPTION**

FIG. 1 is a front left side isometric view of a gripping tongs in accordance with the new design;  
FIG. 2 is a ride side elevational view thereof, the left side elevational view being a mirror image thereof;  
FIG. 3 is a top plan view thereof, the bottom plan view being an identical view thereof;  
FIG. 4 is a rear elevational view thereof; and,  
FIG. 5 is a front elevational view thereof.  
The broken lines shown in FIGS. 1 and 4 illustrate portions of the gripping tongs that form no part of the claimed design.

**1 Claim, 5 Drawing Sheets**

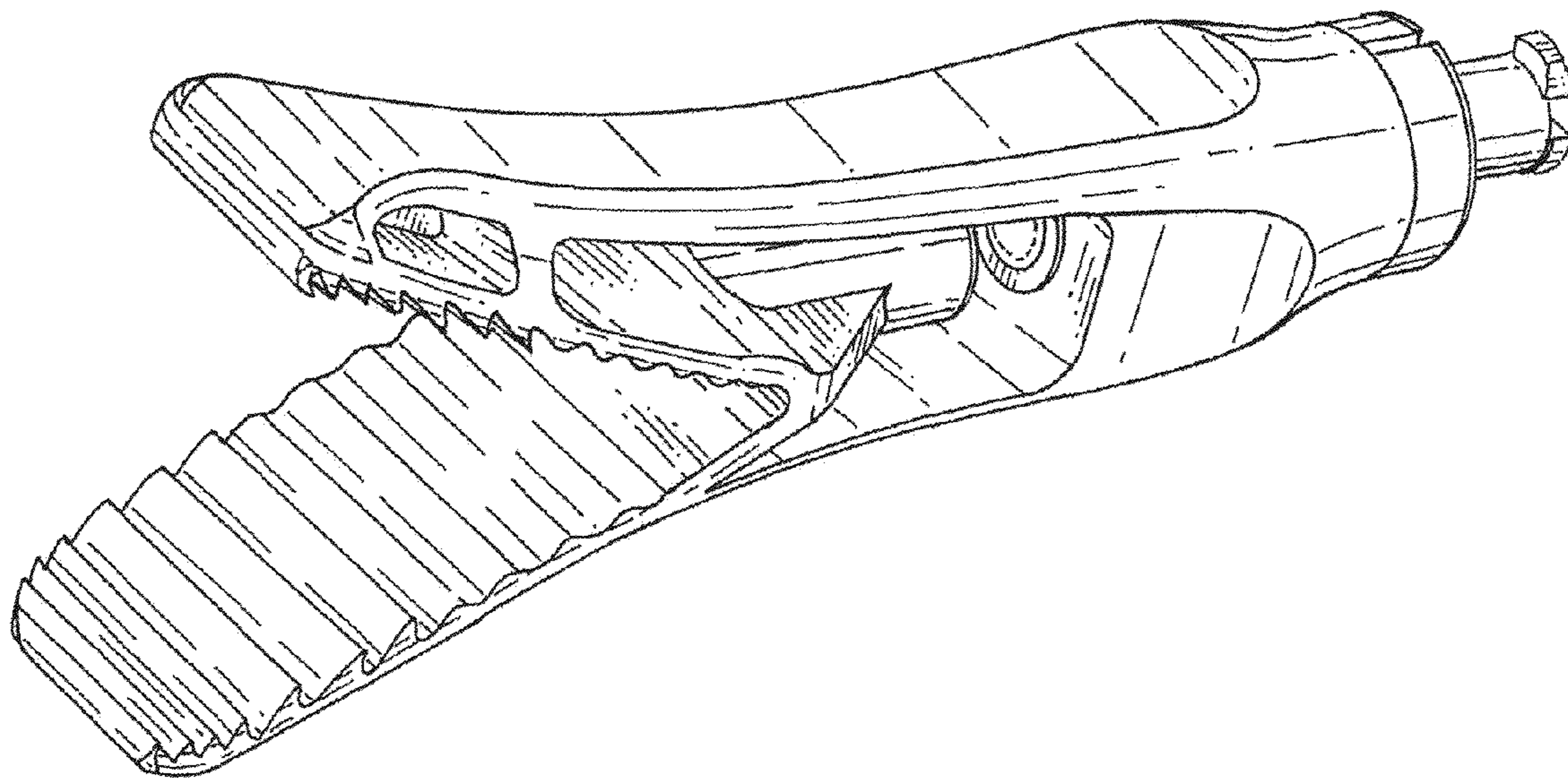

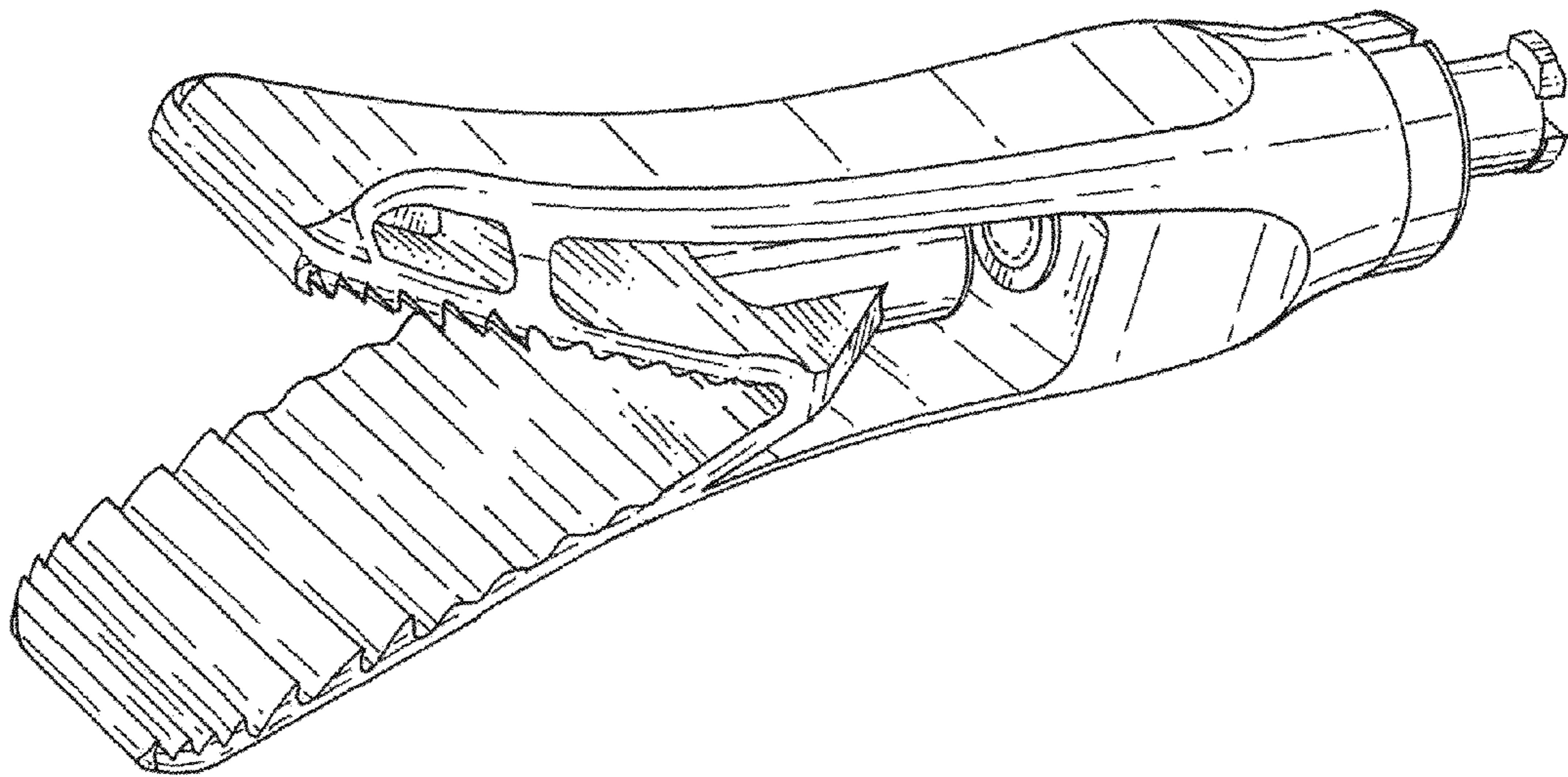

FIG. 1

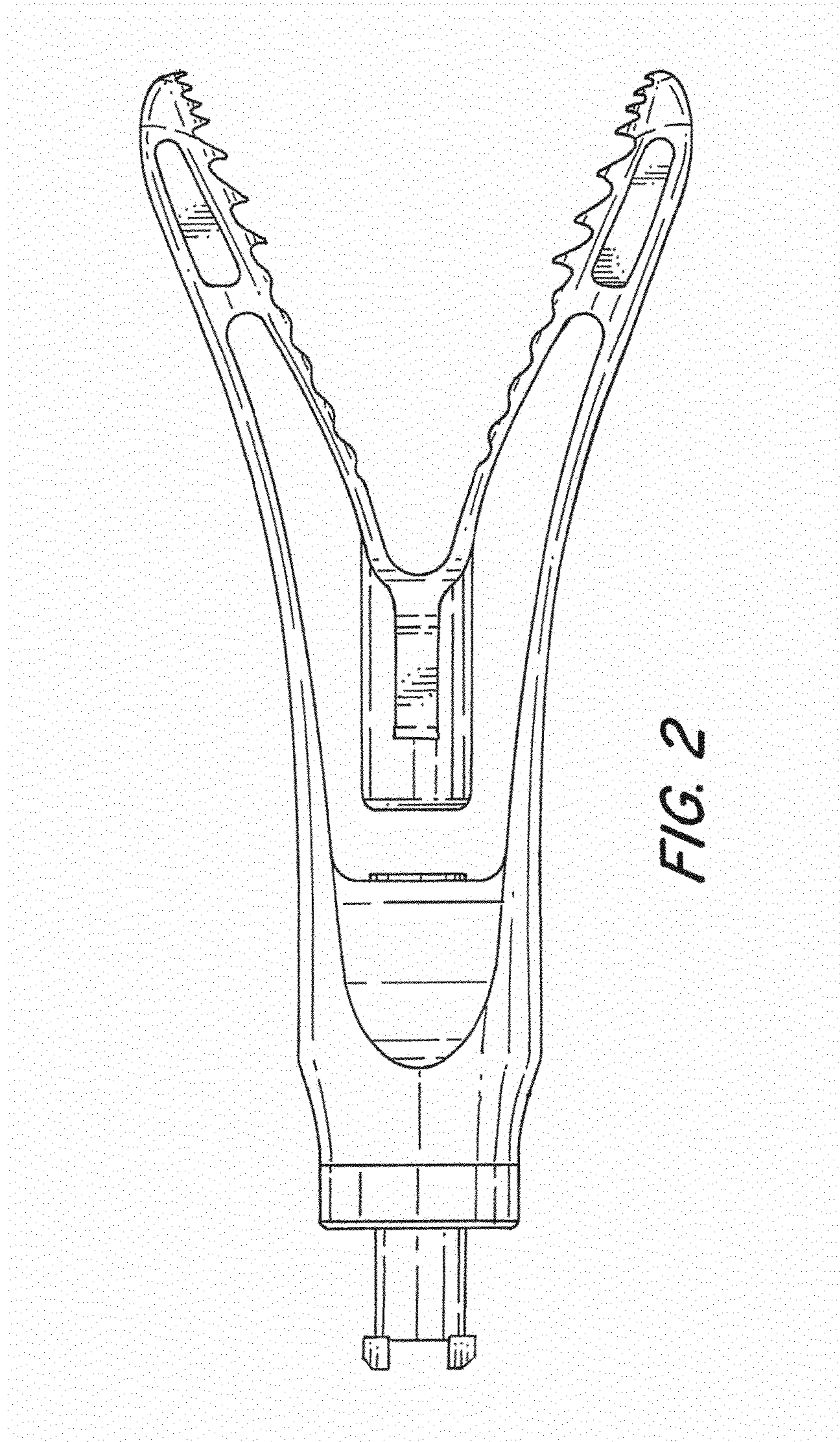
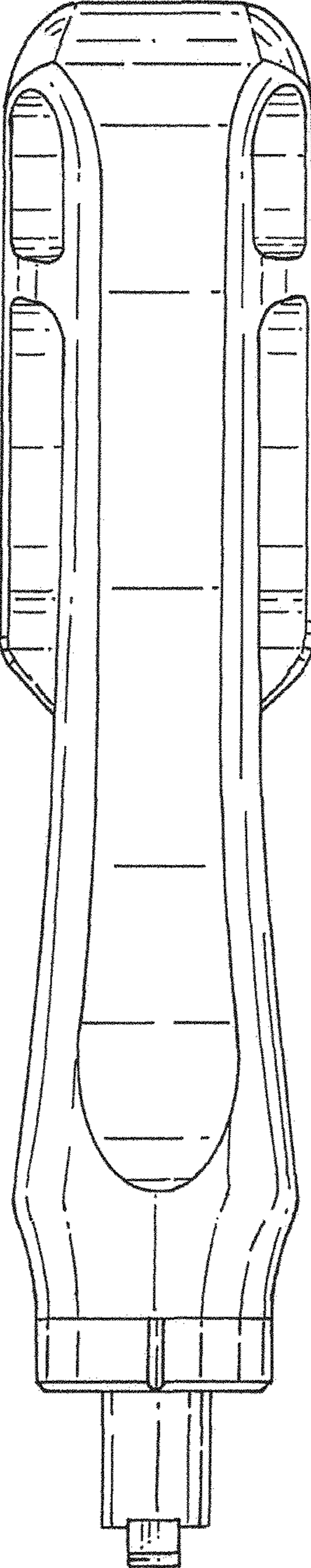
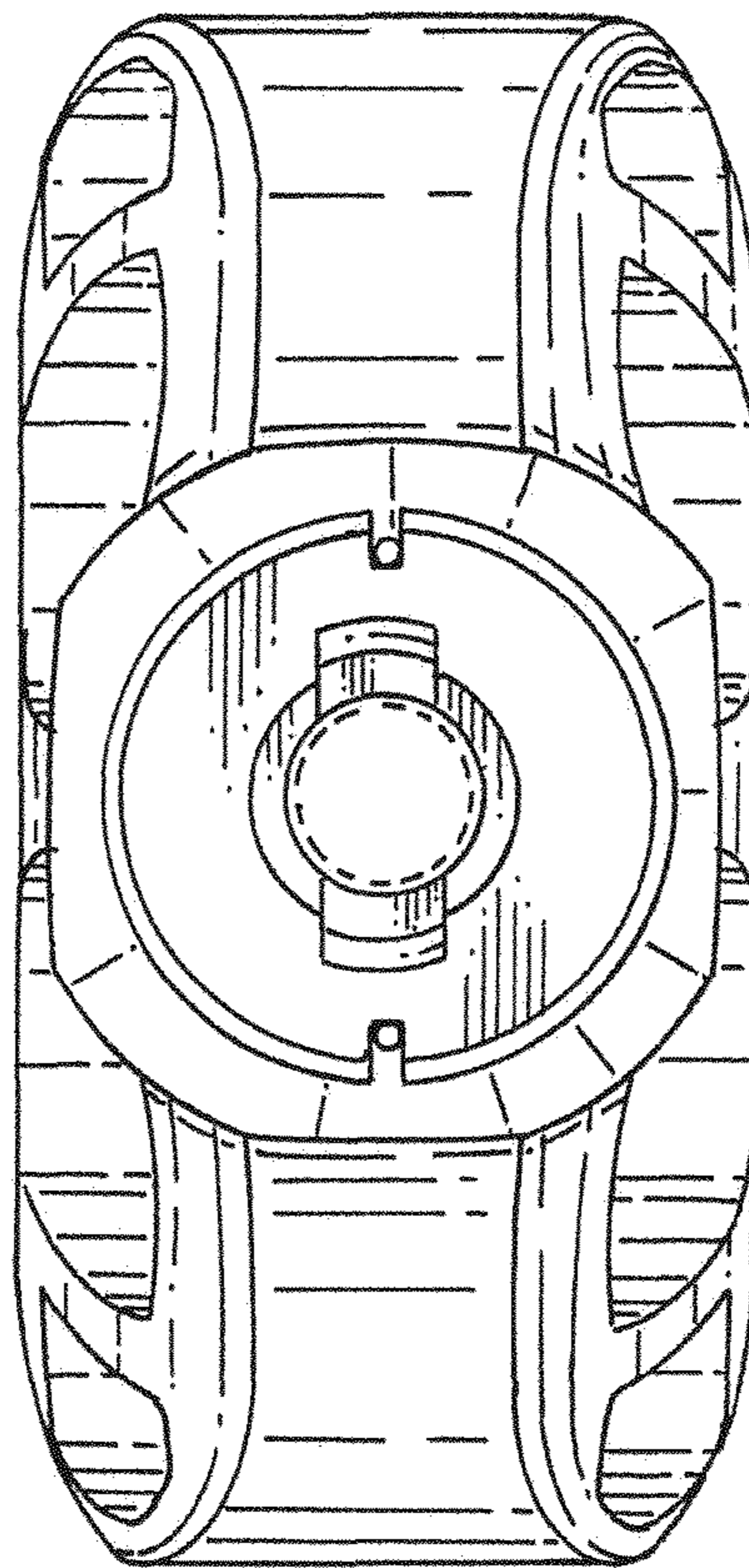

FIG. 2



*FIG. 3*



*FIG. 4*

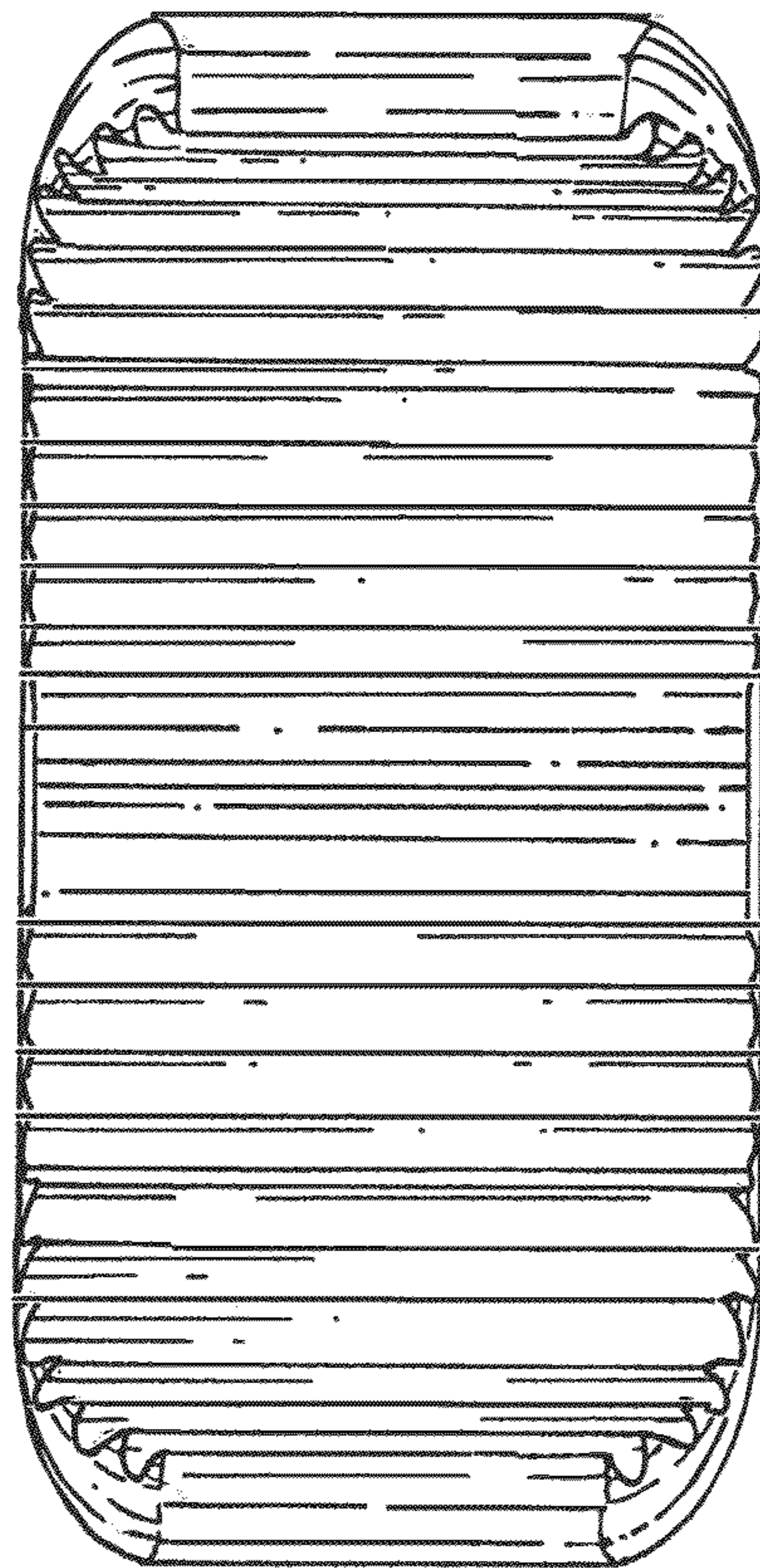

*FIG. 5*