



US00D741735S

(12) **United States Design Patent**
Childress

(10) **Patent No.:** **US D741,735 S**
(45) **Date of Patent:** **** Oct. 27, 2015**

- (54) **LINE WEIGHT INDICATOR DIAL**
- (71) Applicant: **W.C. Bradley/Zebco Holdings, Inc.**,
Tulsa, OK (US)
- (72) Inventor: **Joel Robert Childress**, Glenpool, OK
(US)
- (73) Assignee: **W.C. BRADLEY/ZEBCO**
HOLDINGS, INC., Tulsa, OK (US)
- (**) Term: **14 Years**
- (21) Appl. No.: **29/495,363**
- (22) Filed: **Jun. 30, 2014**
- (51) **LOC (10) Cl.** **10-04**
- (52) **U.S. Cl.**
USPC **D10/87; D22/139**
- (58) **Field of Classification Search**
USPC D10/87, 88, 90; D22/137, 139, 143
CPC ... A01K 87/007; A01K 97/12; A01K 97/125;
A01K 91/20; G01G 19/60
See application file for complete search history.

- D346,754 S * 5/1994 Evers D10/88
- 6,003,263 A 12/1999 Thurber et al.
- D509,558 S 9/2005 Smith
- 2005/0011105 A1 * 1/2005 Cameron et al. 43/17
- 2005/0161543 A1 * 7/2005 Stiner et al. 242/223

* cited by examiner

Primary Examiner — Antoine D Davis

(74) *Attorney, Agent, or Firm* — Fellers, Snider,
Blankenship, Bailey & Tippens, P.C.

(57) **CLAIM**

The ornamental design for a line weight indicator dial, as shown and described.

DESCRIPTION

FIG. 1 is a front elevation view of the line weight indicator dial showing my new design;
FIG. 2 is a right side elevation view thereof;
FIG. 3 is a bottom plan view thereof;
FIG. 4 is a left side elevation view thereof;
FIG. 5 is a top plan view thereof;
FIG. 6 is a rear elevation view thereof; and,
FIG. 7 is an isometric view thereof showing the front and bottom.

The broken lines in the figures are for the purpose of illustrating the environment in which the design is associated and form no part of the claimed design.

- (56) **References Cited**
U.S. PATENT DOCUMENTS
4,535,561 A 8/1985 Hlava
D327,727 S 7/1992 Robbins et al.

1 Claim, 2 Drawing Sheets

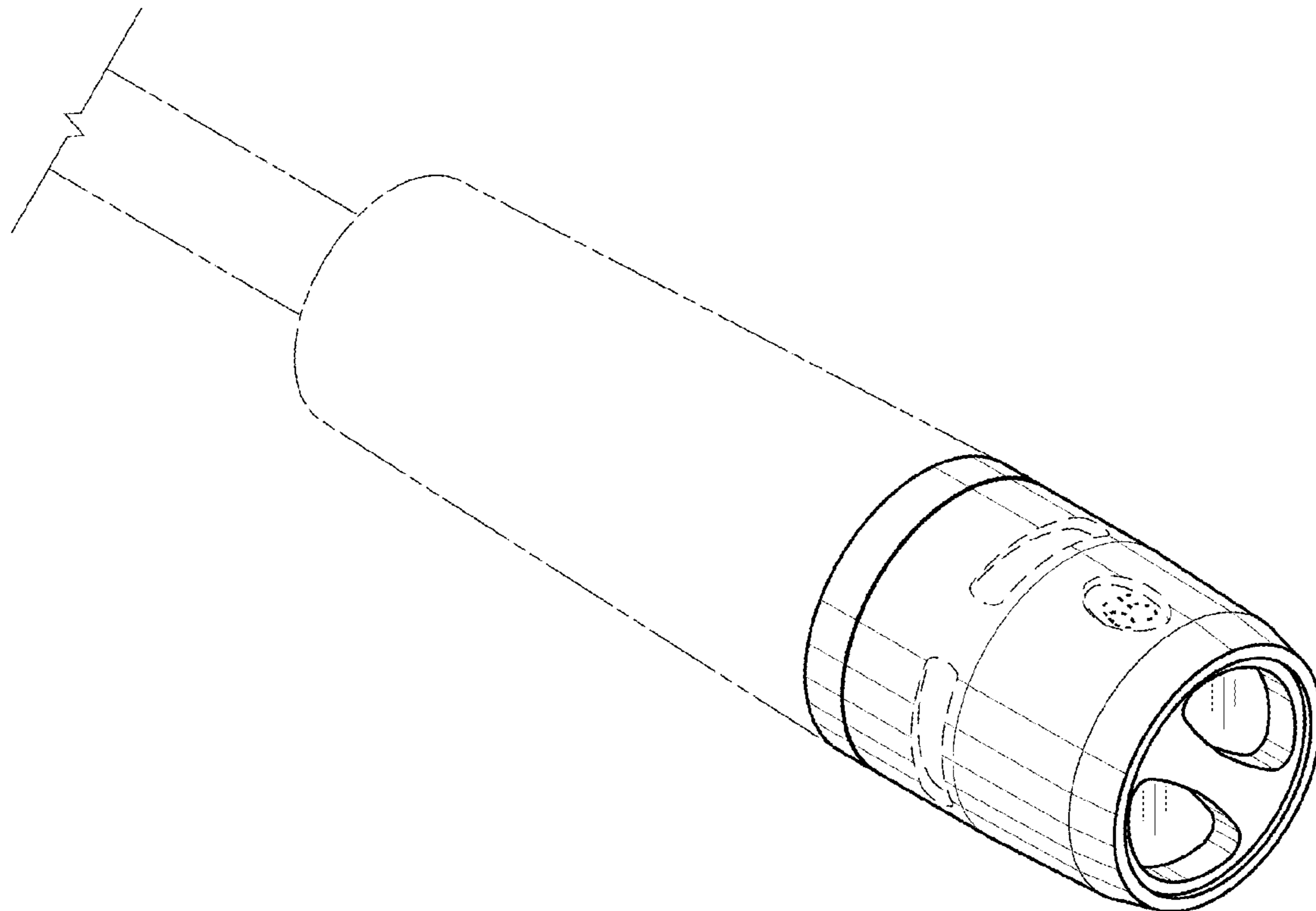

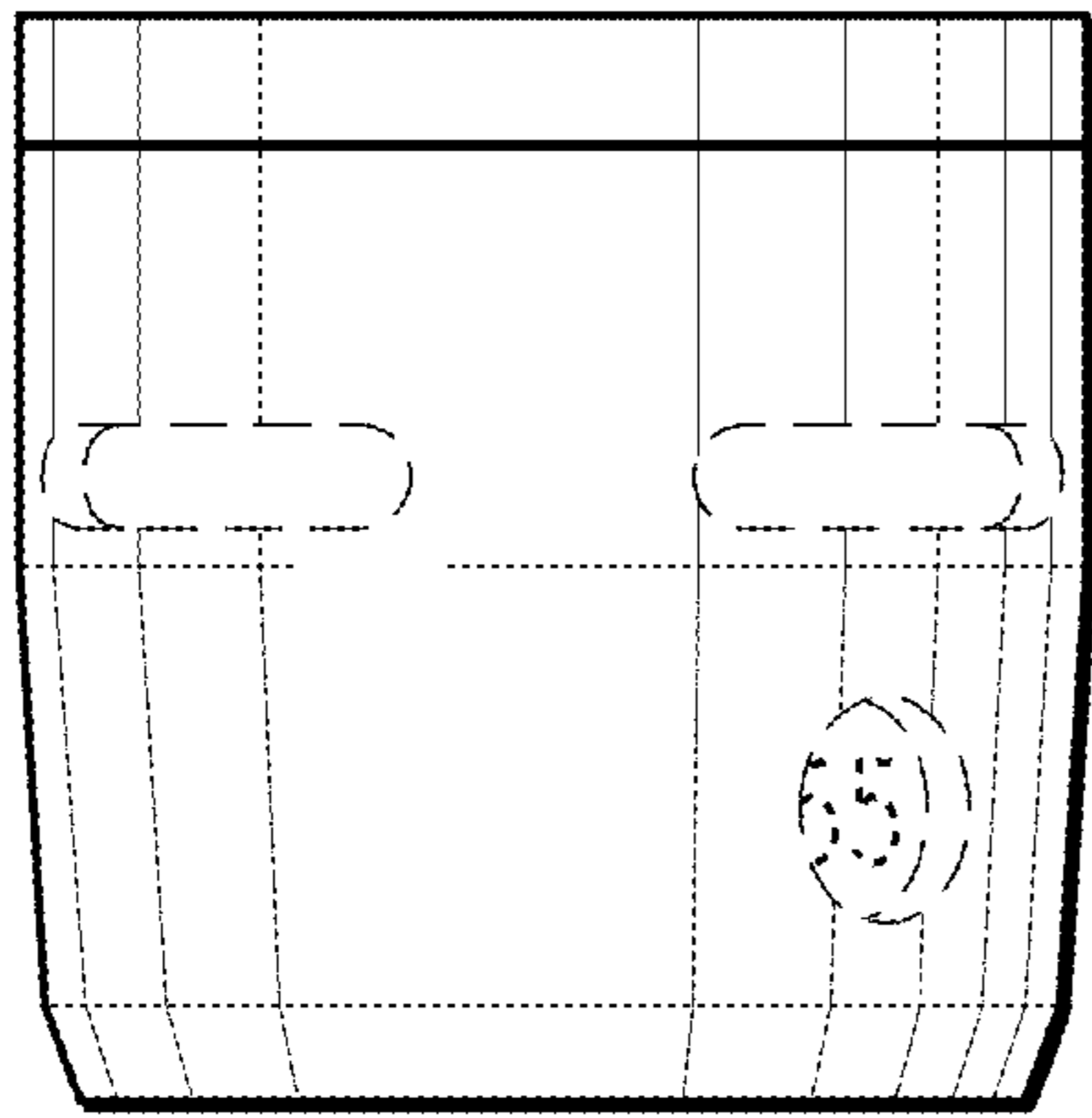

Fig. 1

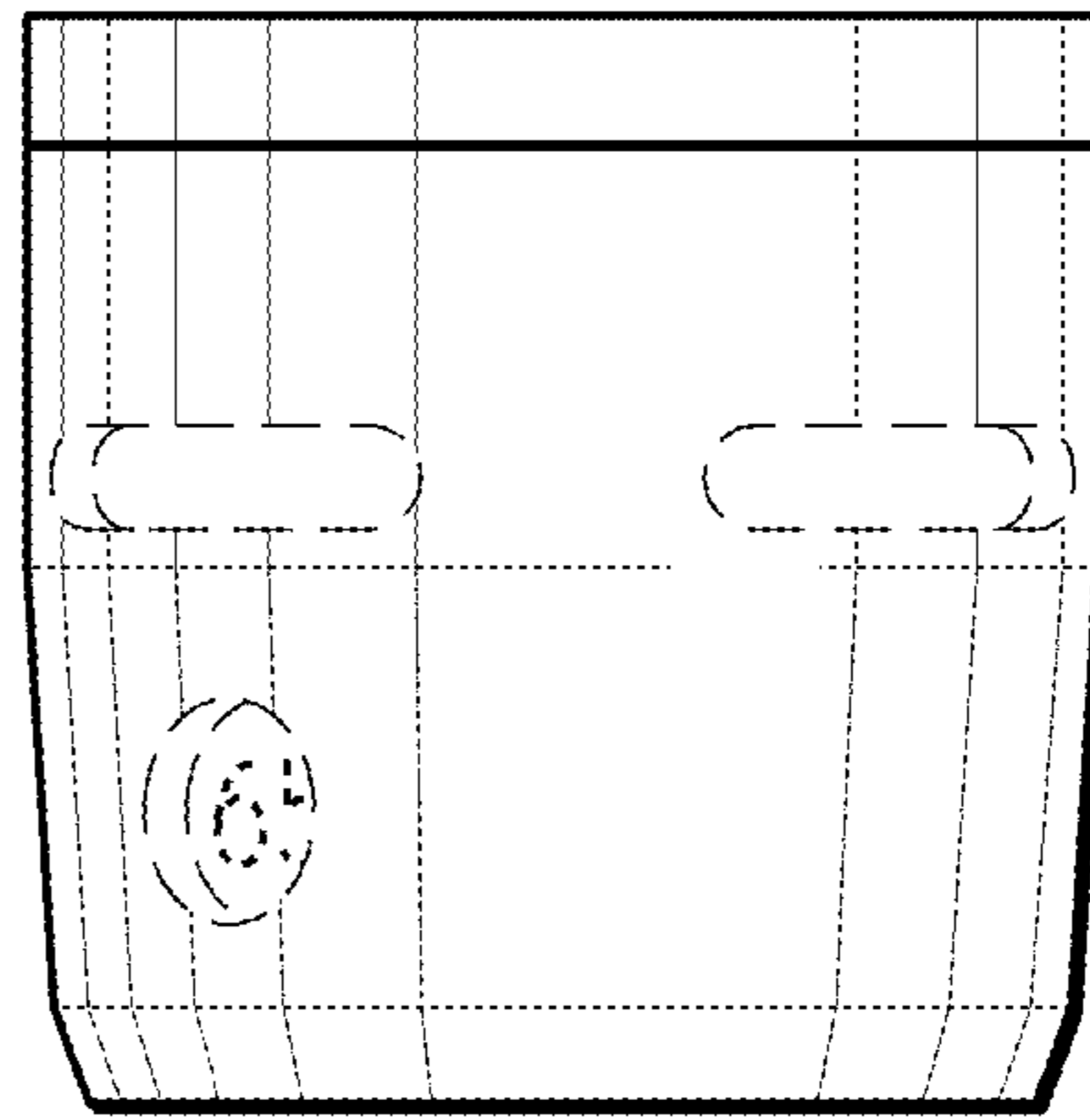

Fig. 2

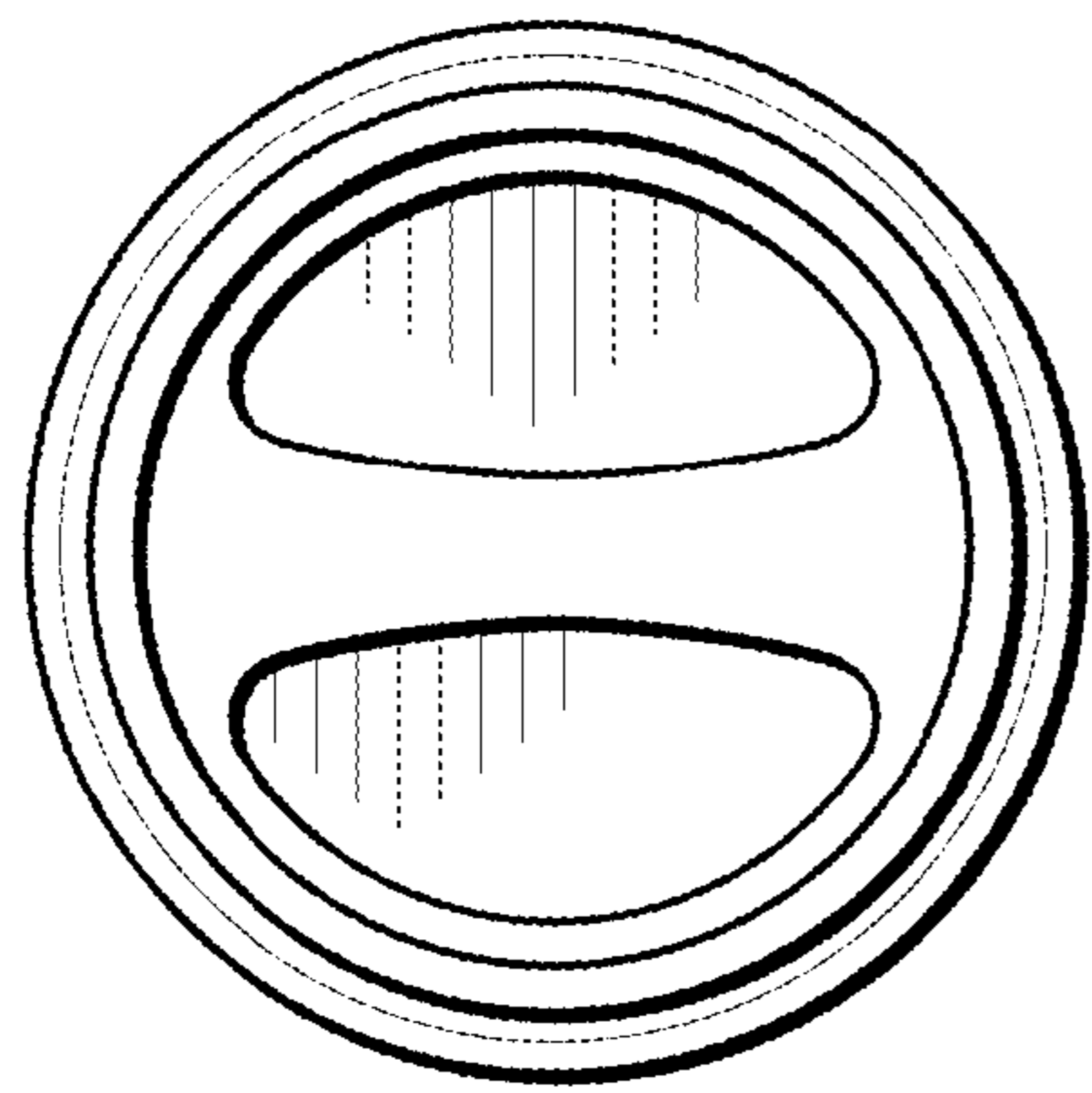

Fig. 3

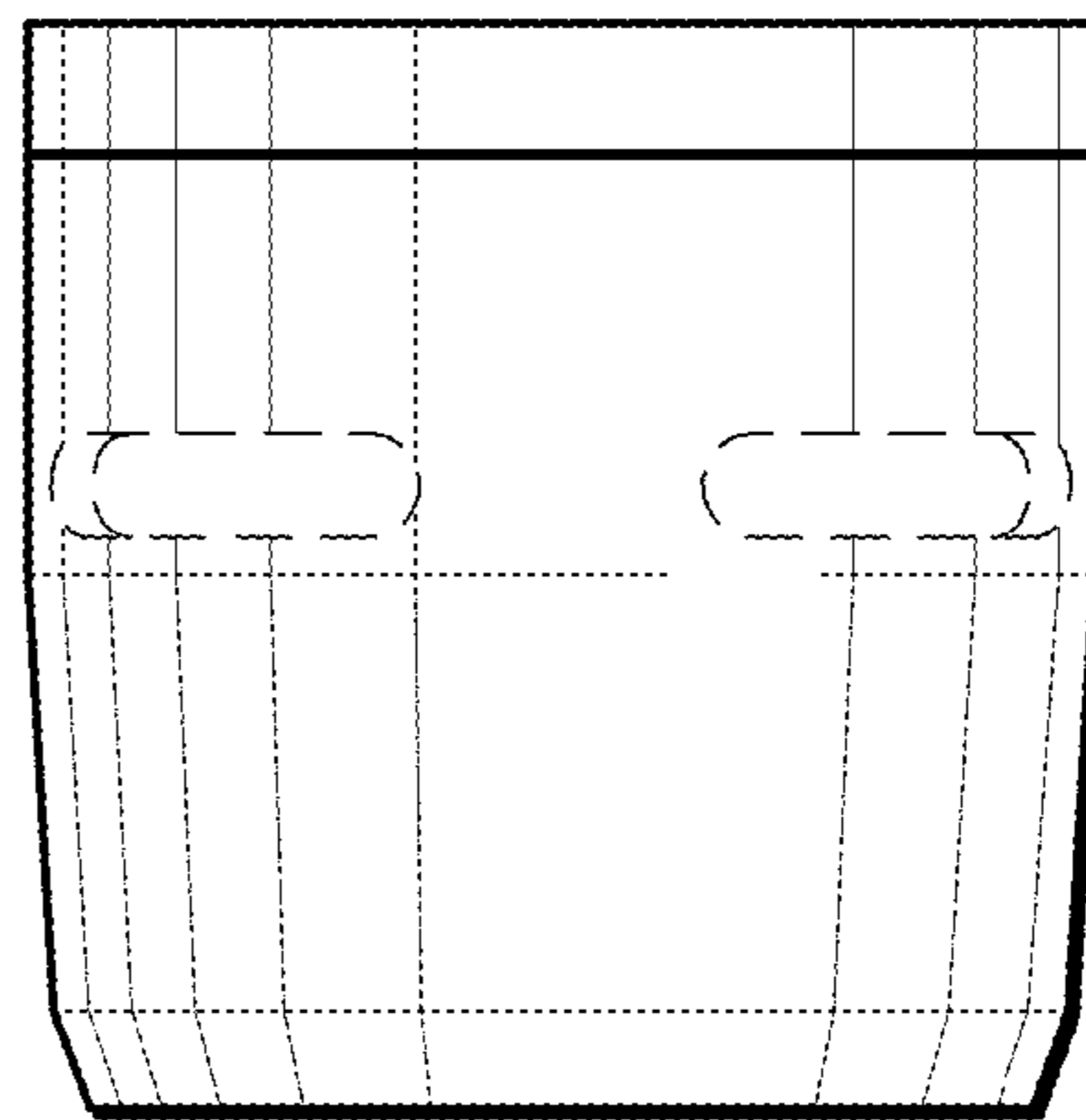

Fig. 4

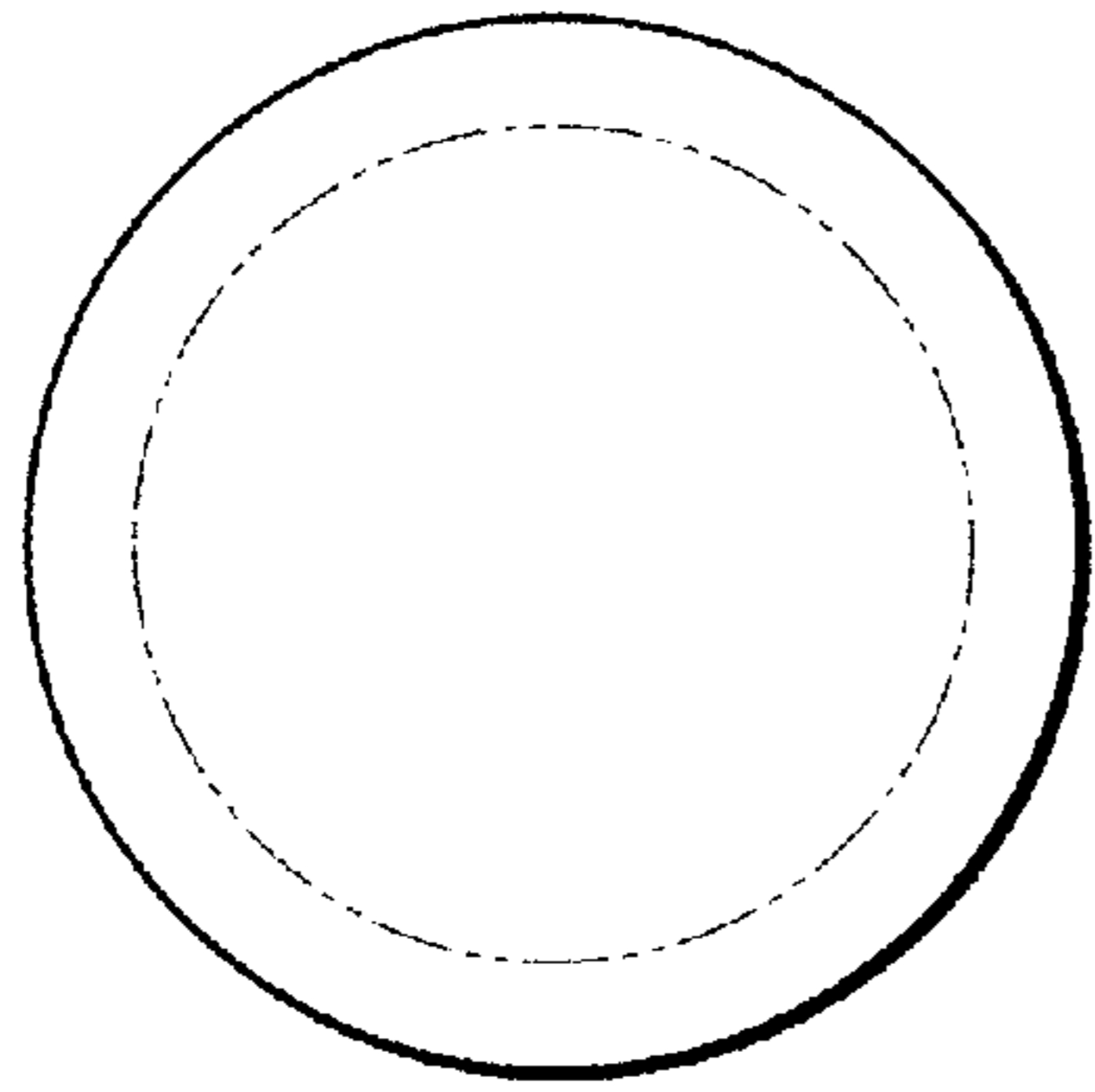

Fig. 5

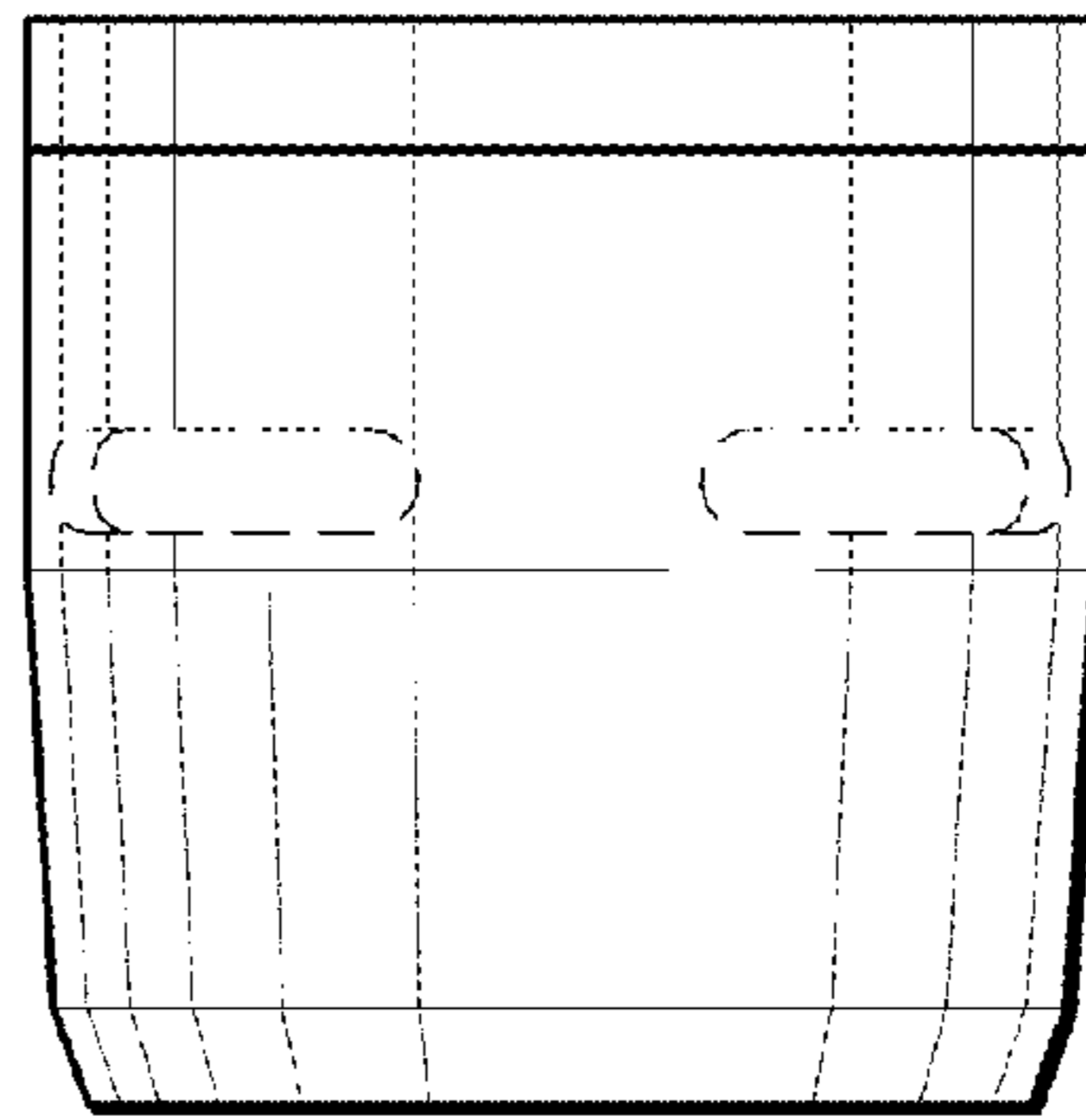

Fig. 6

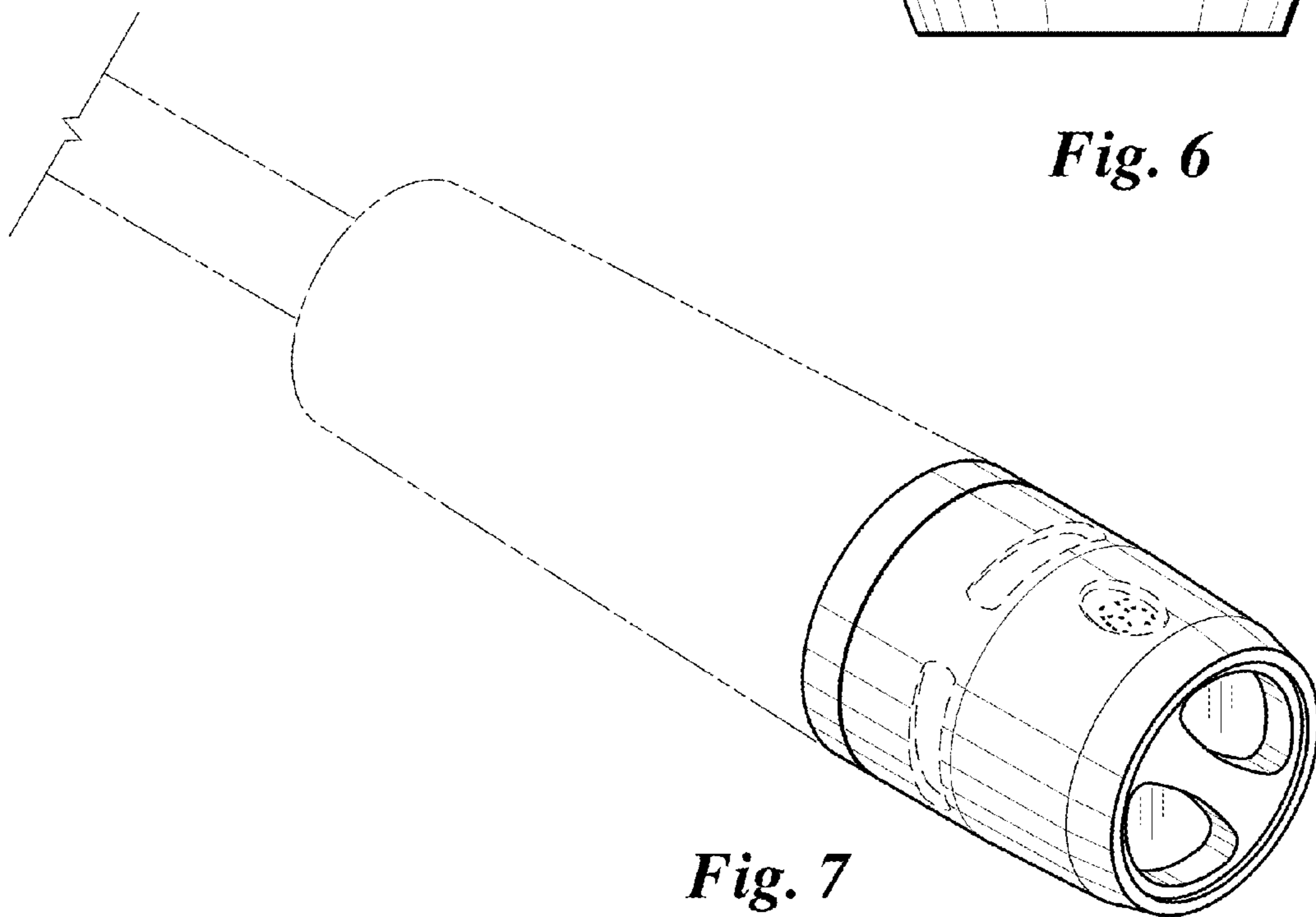

Fig. 7