



US00D741456S

(12) **United States Design Patent**
Elwertowski et al.

(10) **Patent No.:** **US D741,456 S**
(45) **Date of Patent:** **** Oct. 20, 2015**

(54) **CRIMP-STYLE COUPLING DEVICE FOR CLAMPING TOGETHER CAST IRON PIPES, FITTINGS AND THE LIKE**

(71) Applicant: **CHARLOTTE PIPE AND FOUNDRY COMPANY**, Charlotte, NC (US)

(72) Inventors: **Michael Robert Elwertowski**, Flanders, NJ (US); **Maximilian Linder**, Phillipsburg, NJ (US)

(73) Assignee: **Charlotte Pipe and Foundry Company**, Charlotte, NC (US)

(**) Term: **14 Years**

(21) Appl. No.: **29/461,849**

(22) Filed: **Jul. 29, 2013**

Related U.S. Application Data

(63) Continuation-in-part of application No. 13/944,317, filed on Jul. 17, 2013.

(51) **LOC (10) Cl.** **23-01**

(52) **U.S. Cl.**
USPC **D23/259**

(58) **Field of Classification Search**
USPC D23/259, 256, 332, 393, 265, 323, 260, D23/366, 386; D34/32; 24/274 R, 19, 20 R, 24/279, 20 CW, 2; D8/355, 396, 394; D26/138

CPC F16L 33/08; F16L 33/02; F16L 33/035; F16L 33/04; F16L 33/25; B42D 1/08
See application file for complete search history.

(56) **References Cited**

U.S. PATENT DOCUMENTS

968,506 A 8/1910 Blaha
1,261,221 A 4/1918 Dutcher

(Continued)

FOREIGN PATENT DOCUMENTS

JP D1286785 * 11/2006

OTHER PUBLICATIONS

1 Ear Hose Clamp—340 Stainless Steel, Announced Aug. 20, 2012, [Site Visited Jul. 14, 201215] http://www.anzor.com.au/stainless-steel-hose-clamps-hose-clips/1-ear-hose-clamps-304-stainless/product.*

(Continued)

Primary Examiner — Eric Goodman

Assistant Examiner — Luqman McNeil

(74) *Attorney, Agent, or Firm* — Nelson Mullins Riley & Scarborough, LLP

(57) **CLAIM**

The ornamental design for a crimp-style coupling device for clamping together cast iron pipes, fittings and the like, as shown and described.

DESCRIPTION

FIG. 1 is a perspective view of a crimp-style coupling device for clamping together cast iron pipes, fittings and the like, in a flattened condition prior to use; FIG. 2 is a front elevation thereof; FIG. 3 is a rear elevation thereof; FIG. 4 is a top edge thereof; FIG. 5 is a bottom edge thereof; FIG. 6 is a left end edge thereof; FIG. 7 is a right end edge thereof; FIG. 8 is a perspective of the crimp-style coupling device for clamping together cast iron pipes, fittings and the like of FIG. 1, in an annular condition ready for use; FIG. 9 is a front elevation thereof; FIG. 10 is a rear elevation thereof; FIG. 11 is a top plan thereof; FIG. 12 is a bottom plan thereof; FIG. 13 is a left elevation thereof; and, FIG. 14 is a right elevation thereof.

1 Claim, 6 Drawing Sheets

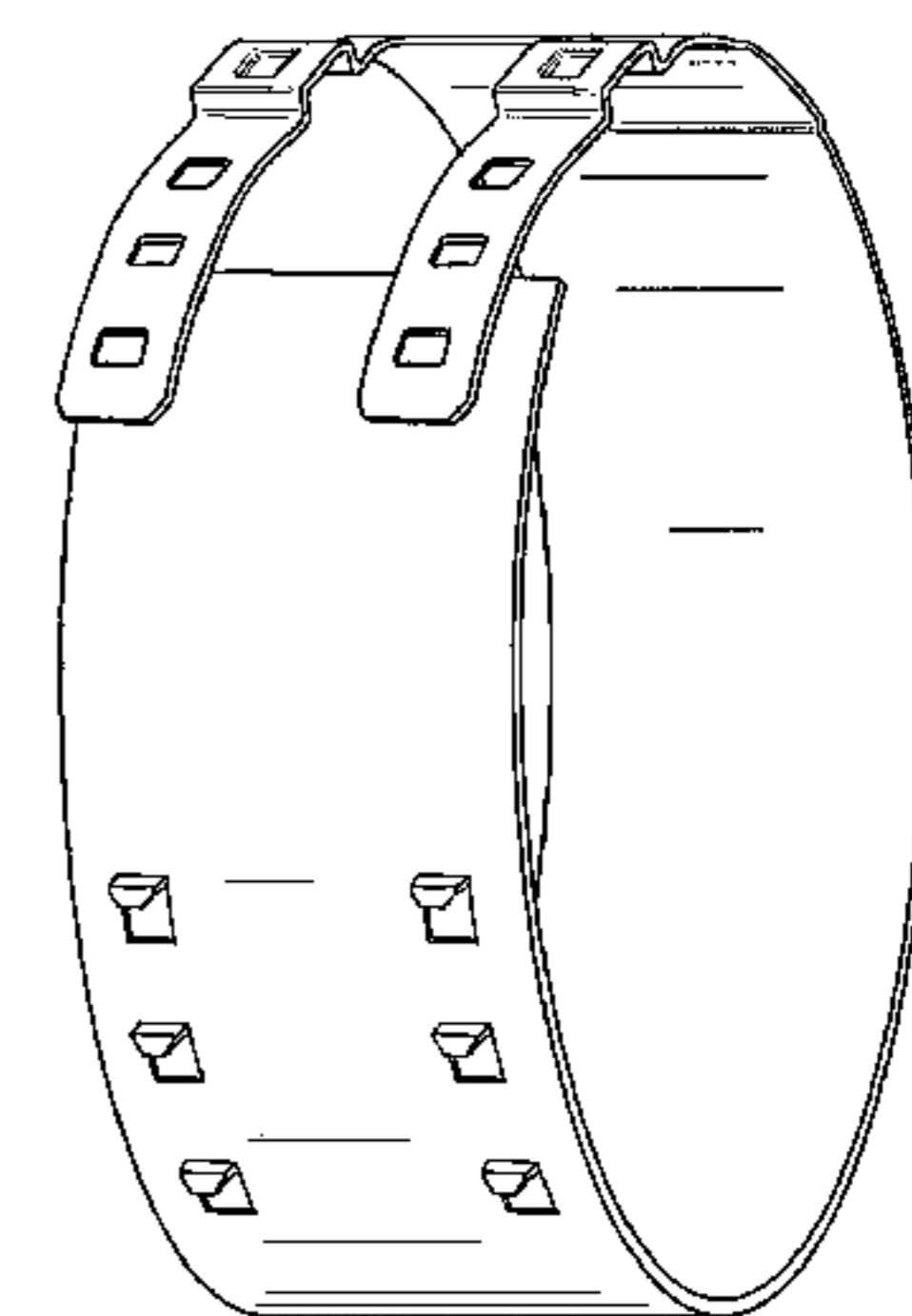
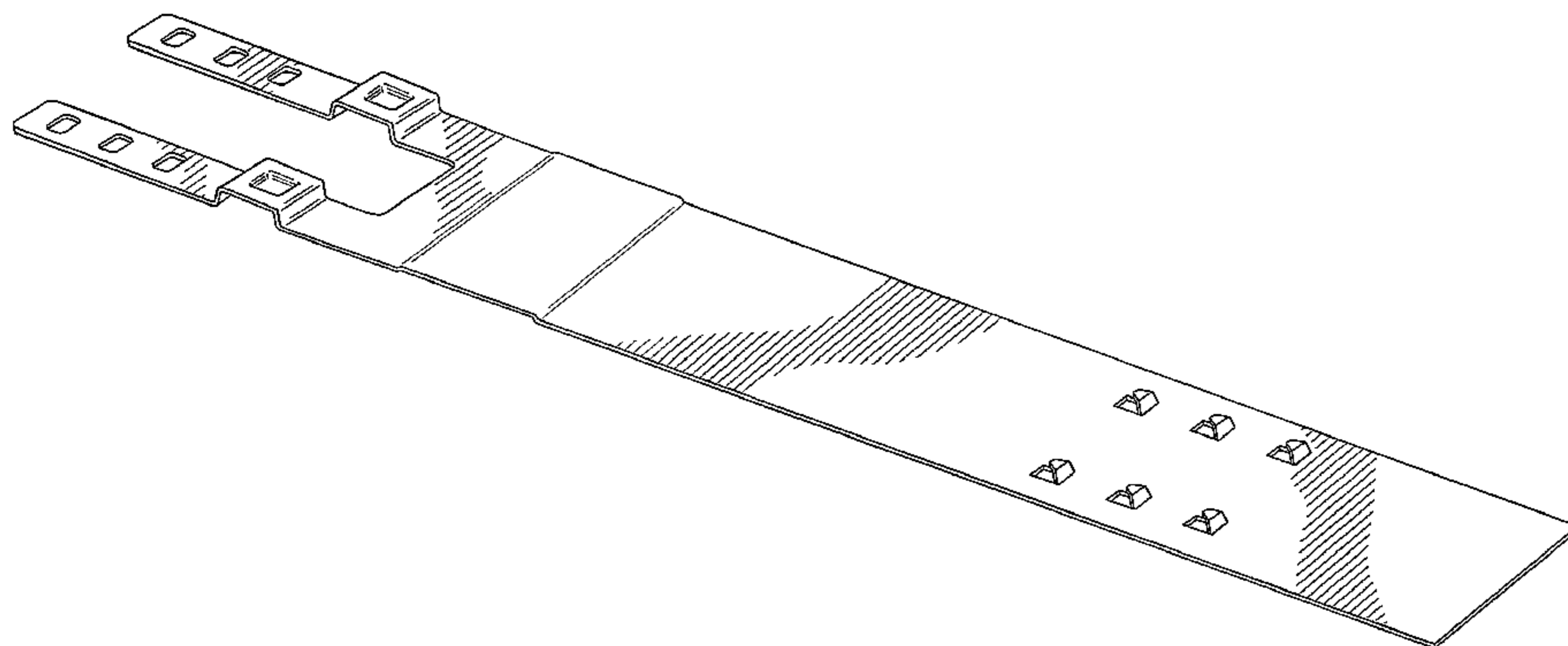

(56)

References Cited

U.S. PATENT DOCUMENTS

1,649,752 A 11/1927 Stone
 1,721,864 A 7/1929 Johnson
 3,154,330 A 10/1964 Clark et al.
 3,233,922 A 2/1966 Evans
 D205,277 S * 7/1966 Gilchrist D23/269
 3,321,811 A 5/1967 Thomas
 3,359,017 A 12/1967 Schaub
 D213,317 S * 2/1969 Nelson D23/259
 3,537,147 A 11/1970 Pfeuffer
 D232,020 S * 7/1974 Borsuk D34/32
 3,950,830 A * 4/1976 Duprez 24/274 R
 4,155,574 A 5/1979 Hulsey
 4,172,607 A 10/1979 Norton
 4,299,012 A * 11/1981 Oetiker 24/19
 D264,045 S * 4/1982 Elliot et al. D8/355
 4,538,837 A 9/1985 Cronk
 4,538,839 A 9/1985 Ledgerwood
 4,564,220 A 1/1986 Sills et al.
 D317,351 S * 6/1991 Takeuchi D23/265
 RE33,934 E 5/1992 Oetiker
 5,138,747 A * 8/1992 Oetiker 24/20 R
 5,309,607 A * 5/1994 Hohmann et al. 24/274 R
 D351,710 S * 10/1994 Richardson D34/32
 5,560,087 A * 10/1996 Marques 24/274 R
 D380,375 S * 7/1997 Rohaly et al. D8/396
 5,706,558 A * 1/1998 Sauer 24/279
 5,713,107 A 2/1998 Jan
 6,000,104 A * 12/1999 Mann 24/274 R
 6,178,601 B1 * 1/2001 Craig, Jr. 24/20 R
 6,240,603 B1 * 6/2001 Craig, Jr. 24/20 CW
 D453,042 S * 1/2002 Mattsson et al. D23/393
 D453,372 S * 2/2002 Pecoskie D23/332
 D456,072 S * 4/2002 Mattsson et al. D23/393

D461,544 S * 8/2002 Crockett, IV D23/265
 D465,061 S * 10/2002 Guthrie D26/138
 D466,652 S * 12/2002 Thurman D23/393
 D473,935 S * 4/2003 Braun D23/260
 D473,936 S * 4/2003 Bryson D23/323
 D474,267 S * 5/2003 Mosley, Sr. D23/366
 6,560,823 B1 * 5/2003 Craig, Jr. 24/19
 D478,202 S * 8/2003 Snyder D23/386
 D483,442 S * 12/2003 Leccacorvi D23/265
 D488,374 S * 4/2004 Hussaini et al. D8/396
 D513,973 S * 1/2006 Cheung D8/394
 7,024,731 B2 * 4/2006 Craig, Jr. 24/20 CW
 7,399,006 B2 7/2008 Jungers
 D600,327 S * 9/2009 Morita D23/265
 D625,175 S * 10/2010 Balcell Comas D8/396
 7,832,062 B2 * 11/2010 Ogino et al. 24/20 R
 7,987,561 B2 8/2011 Zhang
 8,230,556 B2 * 7/2012 Palau Dominguez 24/20 R
 D672,230 S * 12/2012 Laverack et al. D8/396

OTHER PUBLICATIONS

Crimp Hose Clamp (21 mm), Announced Nov. 21, 2011, [Site Visted Jul. 14, 2015] <http://www.ipdusa.com/products/4778/113288-crimp-hose-clamp-21mm>.
 Medium Pressure Fuel Hose Clamp, Announced Jan. 6, 2010, [Site Visited Jul. 14, 2015] http://www.simyamaha.com/Yamaha_Fuel_Hose_Clamp_p/651-24387-00-00.htm.
 Google search results—Images for crimp hose clamps, Internet pages—<http://www.google.com>.
 Charlotte Pipe and Foundry Company, “Cast Iron—Technical and Installation Manual”, copyright 2002-2012, pp. 1-48, www.charlottepipe.com.

* cited by examiner

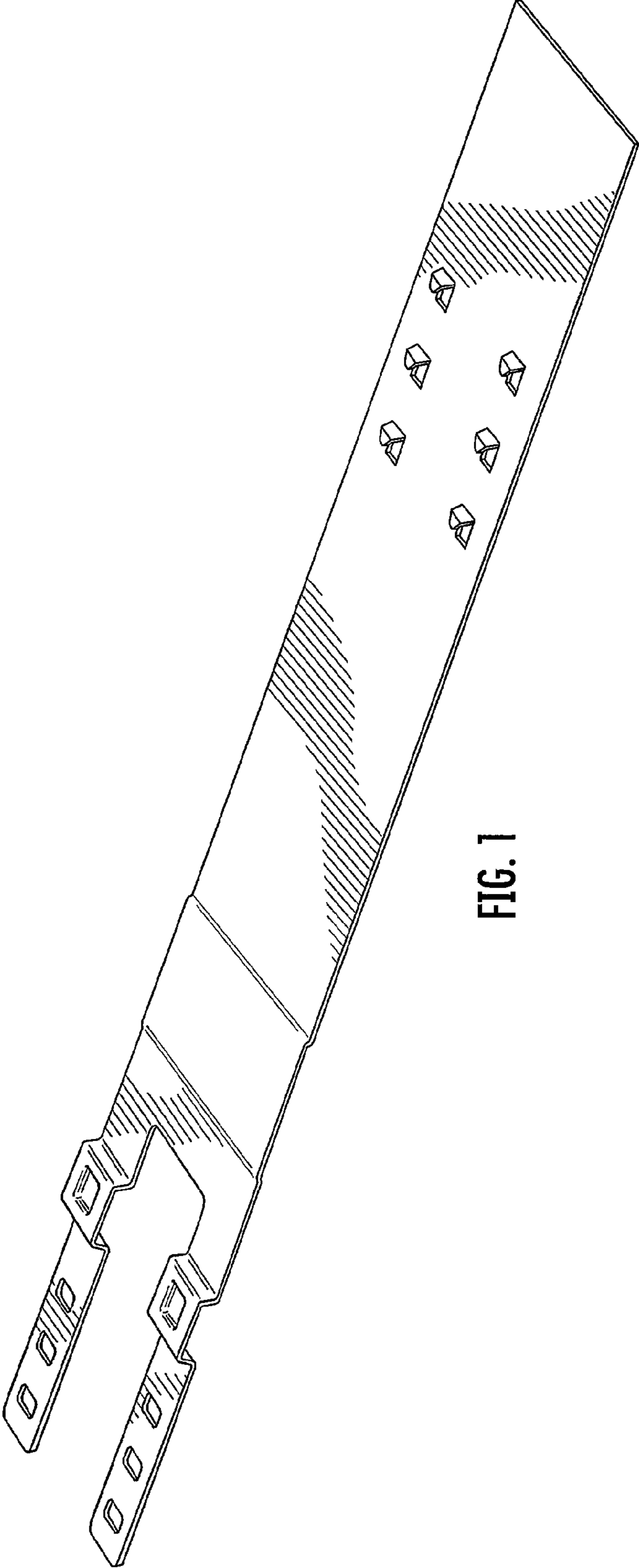

FIG. 7

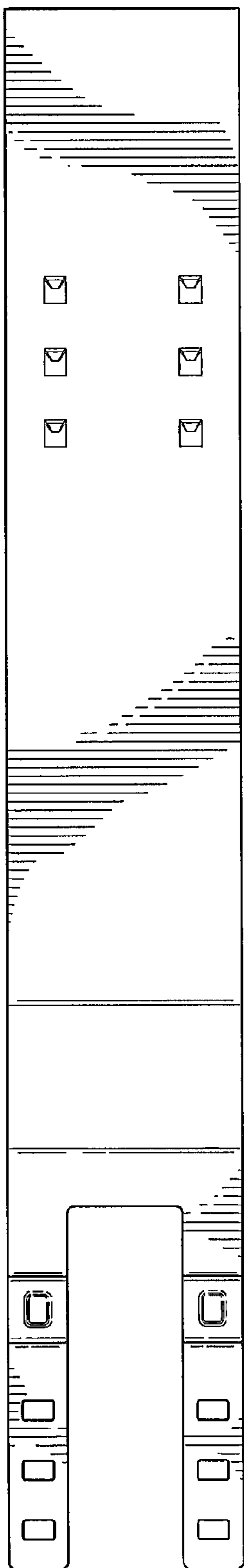

FIG. 2

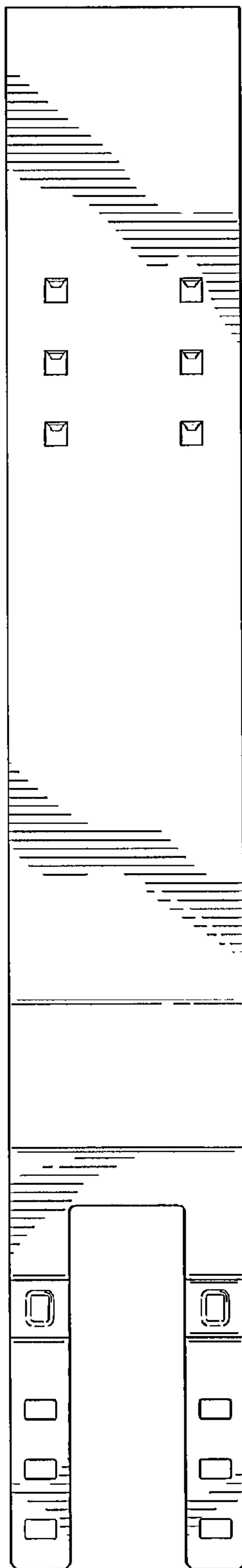

FIG. 3



FIG. 4



FIG. 5



FIG. 6



FIG. 7

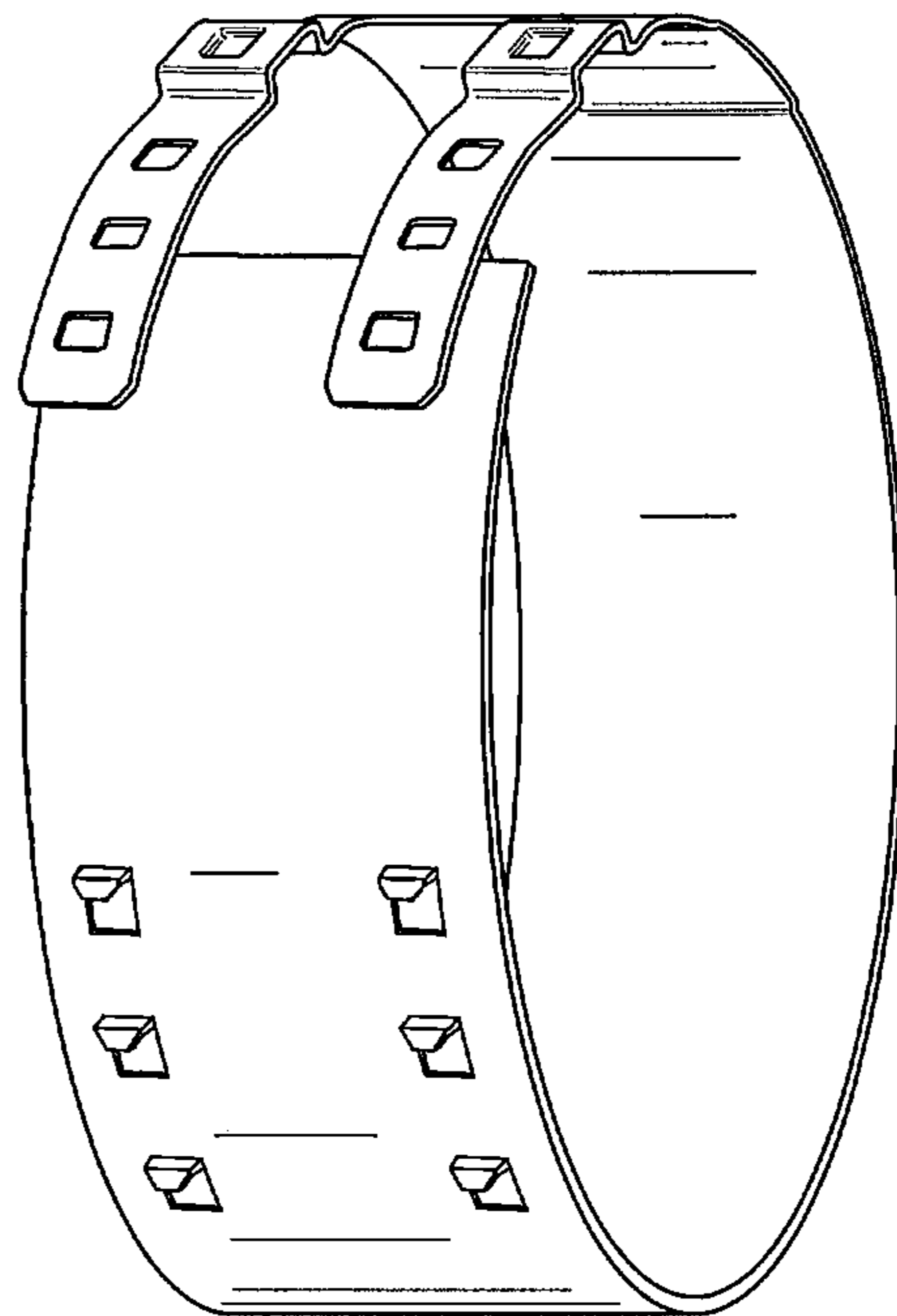

FIG. 8

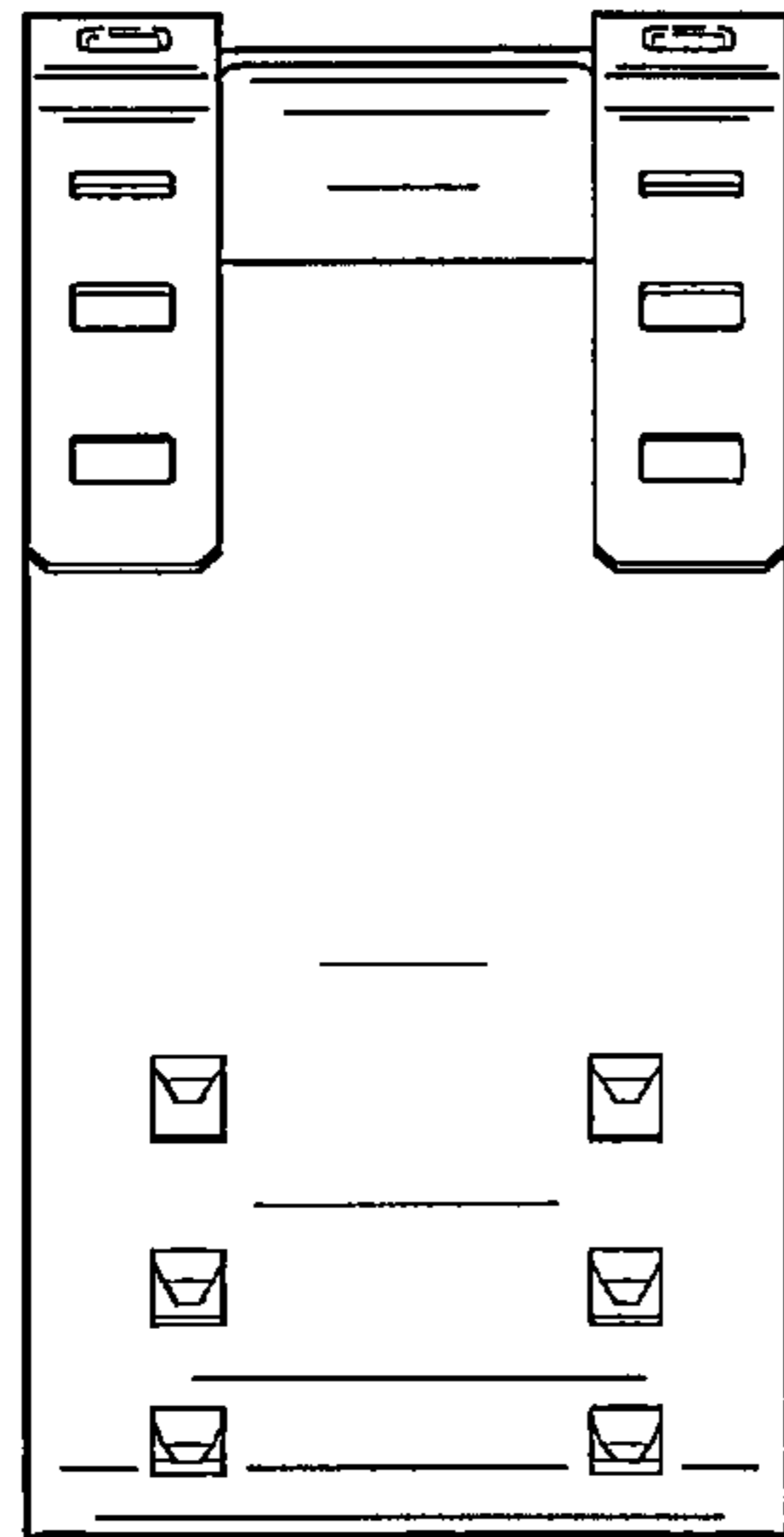

FIG. 9

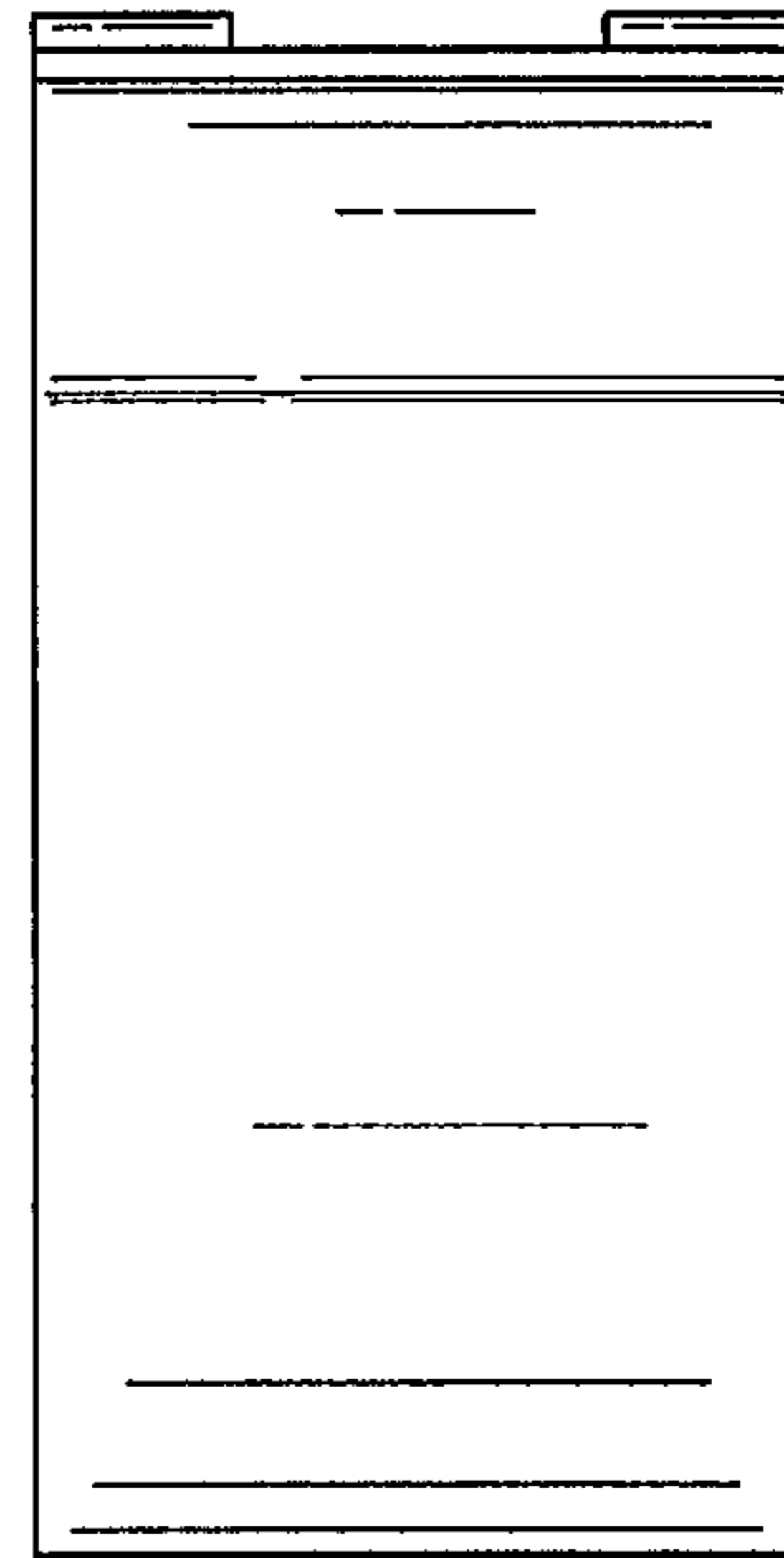

FIG. 10

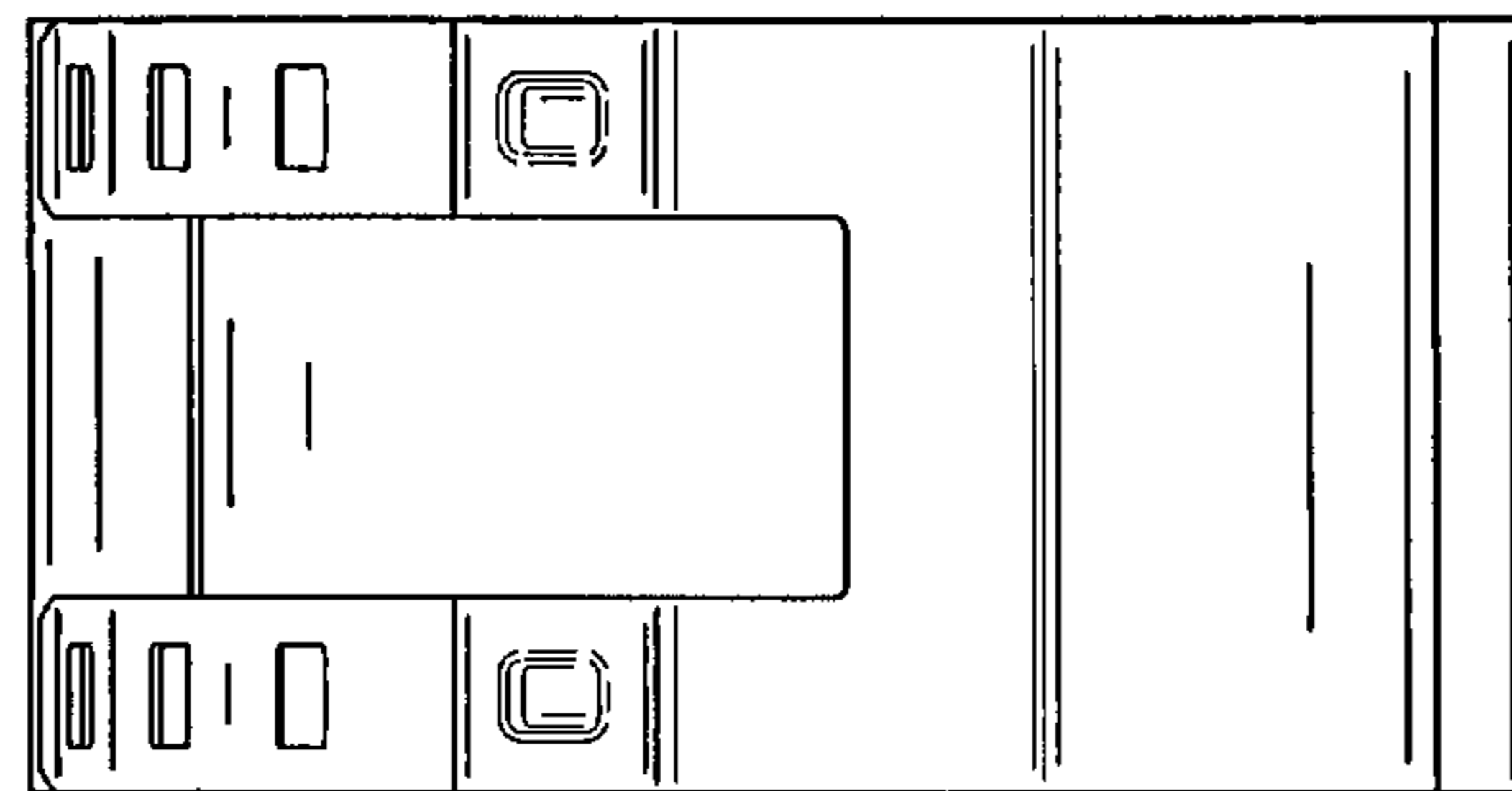

FIG. 11

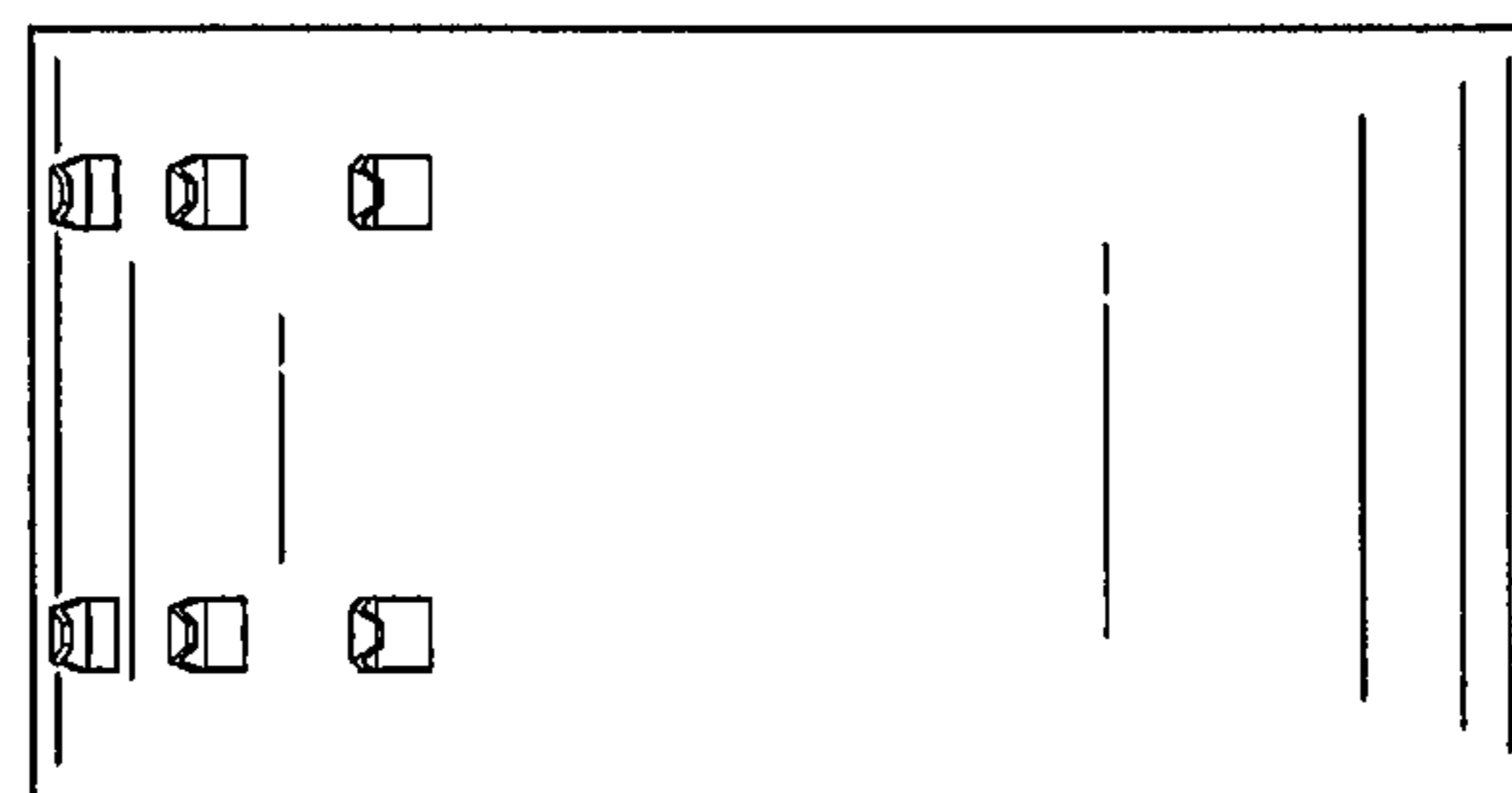

FIG. 12

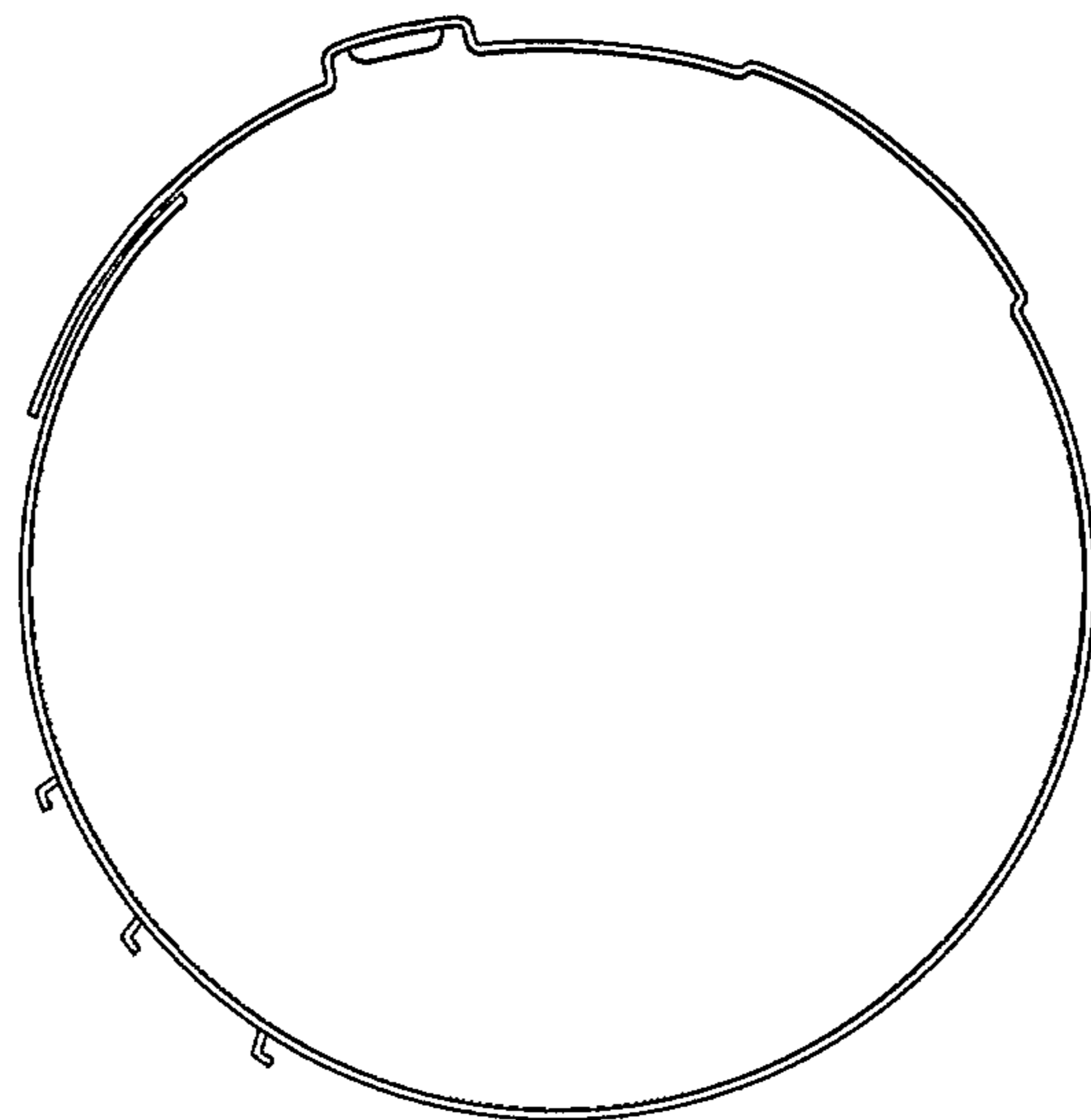

FIG. 13

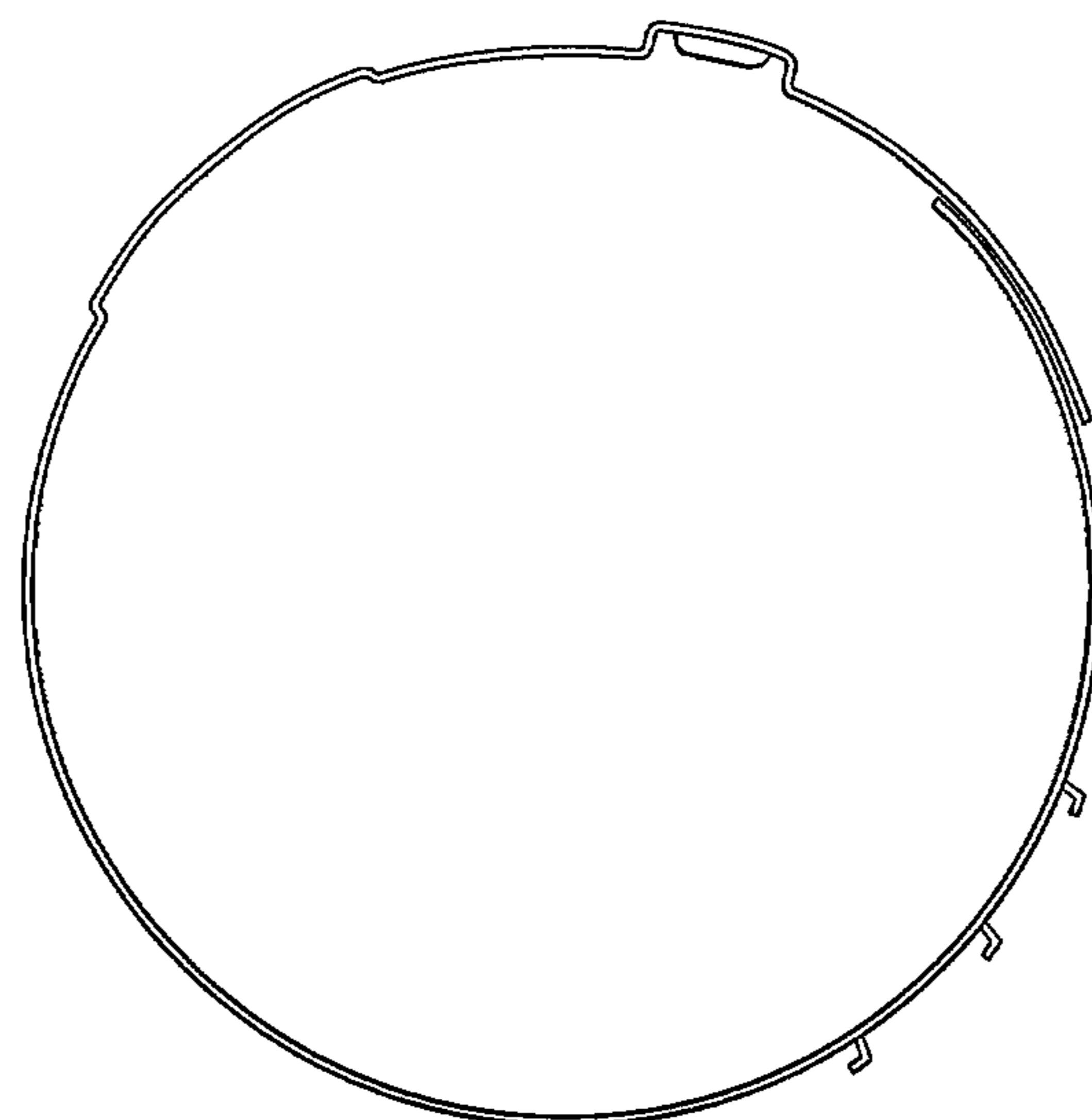

FIG. 14