



US00D740368S

(12) **United States Design Patent**
Norman et al.

(10) **Patent No.:** **US D740,368 S**

(45) **Date of Patent:** **** Oct. 6, 2015**

(54) **ROBOTIC BUMP SWITCH FOR A ROBOTIC CONSTRUCTION KIT**

(56) **References Cited**

U.S. PATENT DOCUMENTS

(71) Applicant: **Innovation First, Inc.**, Greenville, TX (US)

D395,682	S	*	6/1998	Bartholdy et al.	D21/484
D410,976	S	*	6/1999	Poulsen	D21/502
D434,390	S	*	11/2000	Omata	D13/158
D462,666	S	*	9/2002	Yamasaki et al.	D13/158
D593,960	S	*	6/2009	Boss et al.	D13/158
D693,416	S	*	11/2013	Webb	D21/486
D695,230	S	*	12/2013	Zhang et al.	D13/158
D705,874	S	*	5/2014	Norman et al.	D21/491
D724,028	S	*	3/2015	Norman et al.	D13/123
D725,037	S	*	3/2015	Norman et al.	D13/112
D726,127	S	*	4/2015	Gole et al.	D13/158
D731,449	S	*	6/2015	Norman et al.	D13/184
2015/0158184	A1	*	6/2015	Kamijo et al.	74/490.05

(72) Inventors: **David Anthony Norman**, Greenville, TX (US); **Robert H. Mimplitch, III**, Rowlett, TX (US); **Paul David Copioli**, Rockwall, TX (US); **Gregory James Lavender**, Rockwall, TX (US); **Aren Calder Hill**, Rockford, IL (US); **Douglas Michael Galletti**, Allen, TX (US); **John Edward Vielkind-Neun**, Rockwall, TX (US); **Arthur Philip Dutra, IV**, Greenville, TX (US)

* cited by examiner

(73) Assignee: **Innovation First, Inc.**, Greenville, TX (US)

Primary Examiner — Robert M Spear

Assistant Examiner — Kendra L Hamilton

(**) Term: **14 Years**

(74) *Attorney, Agent, or Firm* — Adam K. Sacharoff; Much Shelist

(21) Appl. No.: **29/451,412**

(57) **CLAIM**

The ornamental design for a robotic bump switch for a robotic construction kit, as shown and described.

(22) Filed: **Apr. 2, 2013**

DESCRIPTION

(51) **LOC (10) Cl.** **13-03**

FIG. 1 is a front-top perspective view of a bump switch for a robotic construction kit;

(52) **U.S. Cl.**

FIG. 2 is a rear-side perspective view of FIG. 1;

USPC **D21/158**

FIG. 3 is a front-bottom perspective view of FIG. 1;

(58) **Field of Classification Search**

FIG. 4 is a rear-bottom perspective view of FIG. 1;

USPC D21/484, 485, 491, 499, 500, 501, 502; D8/382; 446/69, 91, 108, 111, 112, 446/116, 120, 122; 318/567, 568.11, 318/568.12; 434/259, 403; 52/503; 273/156, 160; 361/622; 74/490.01, 74/490.05; D13/158, 154, 173, 123

FIG. 5 is a top side view of FIG. 1;

FIG. 6 is a bottom side view of FIG. 1;

FIG. 7 is a right side view of FIG. 1;

FIG. 8 is a left side view of FIG. 1;

FIG. 9 is a front side view of FIGS. 1; and,

FIG. 10 is a rear side view of FIG. 1.

CPC B25J 9/101

See application file for complete search history.

1 Claim, 10 Drawing Sheets

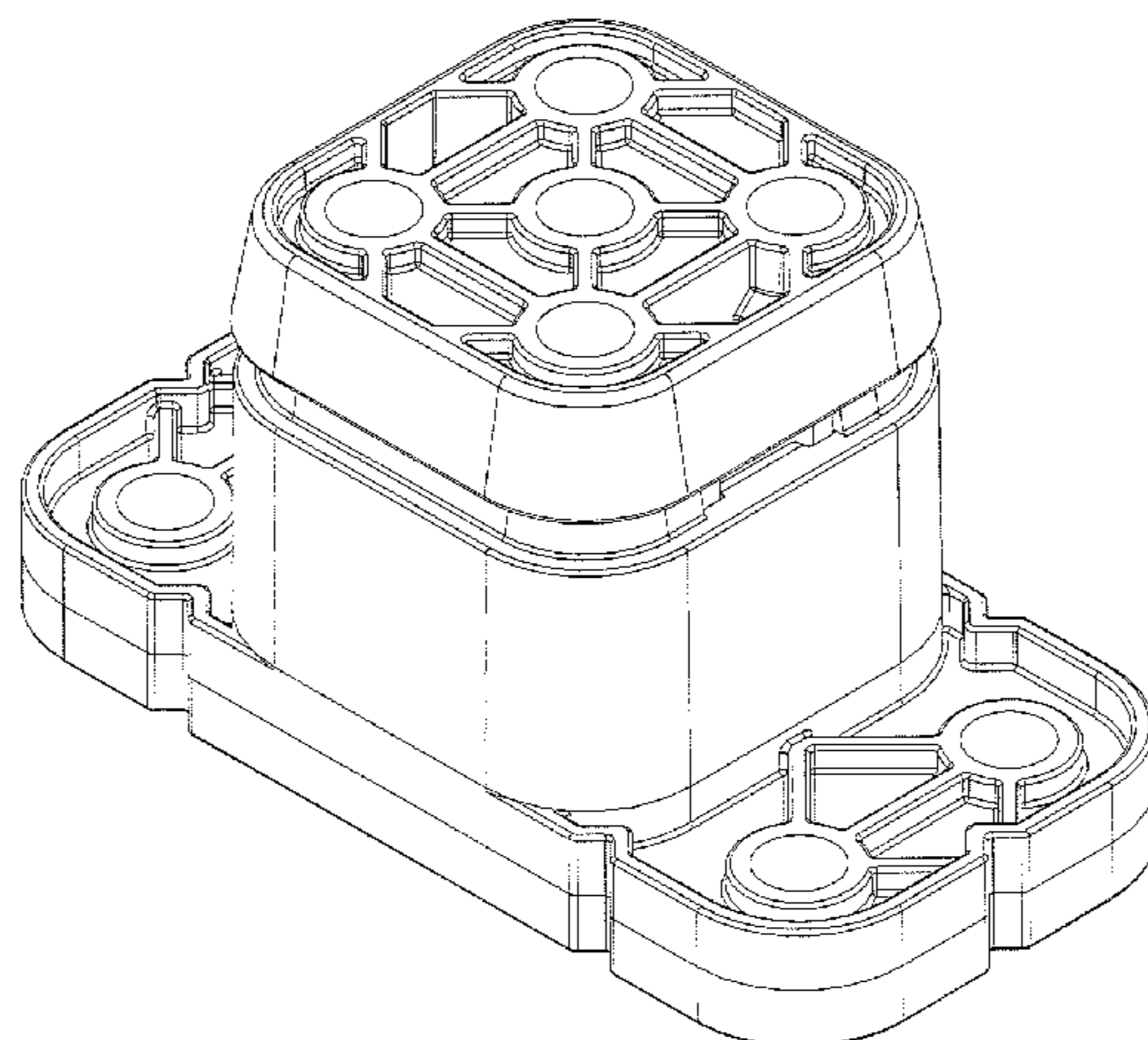

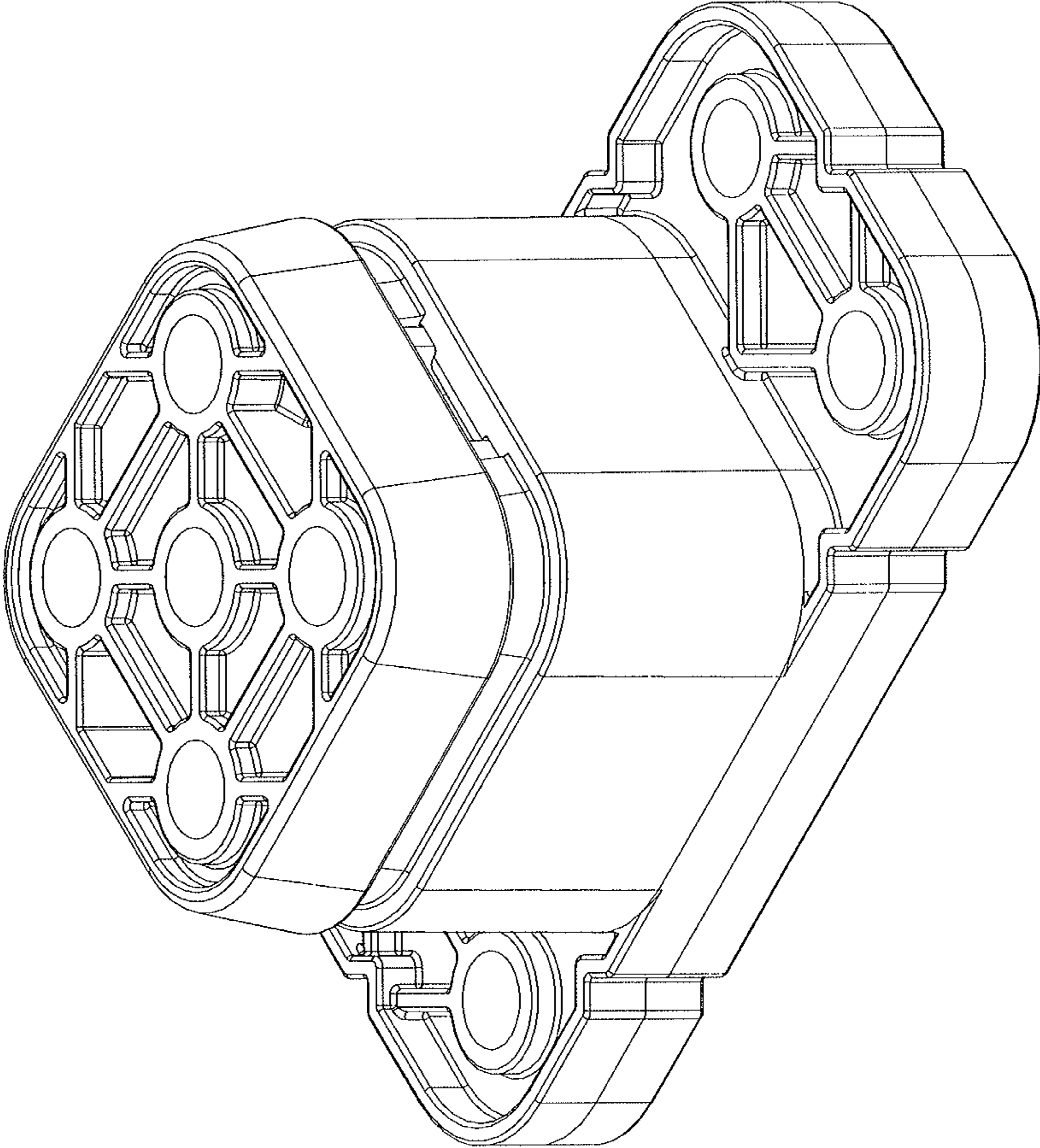

FIGURE 1

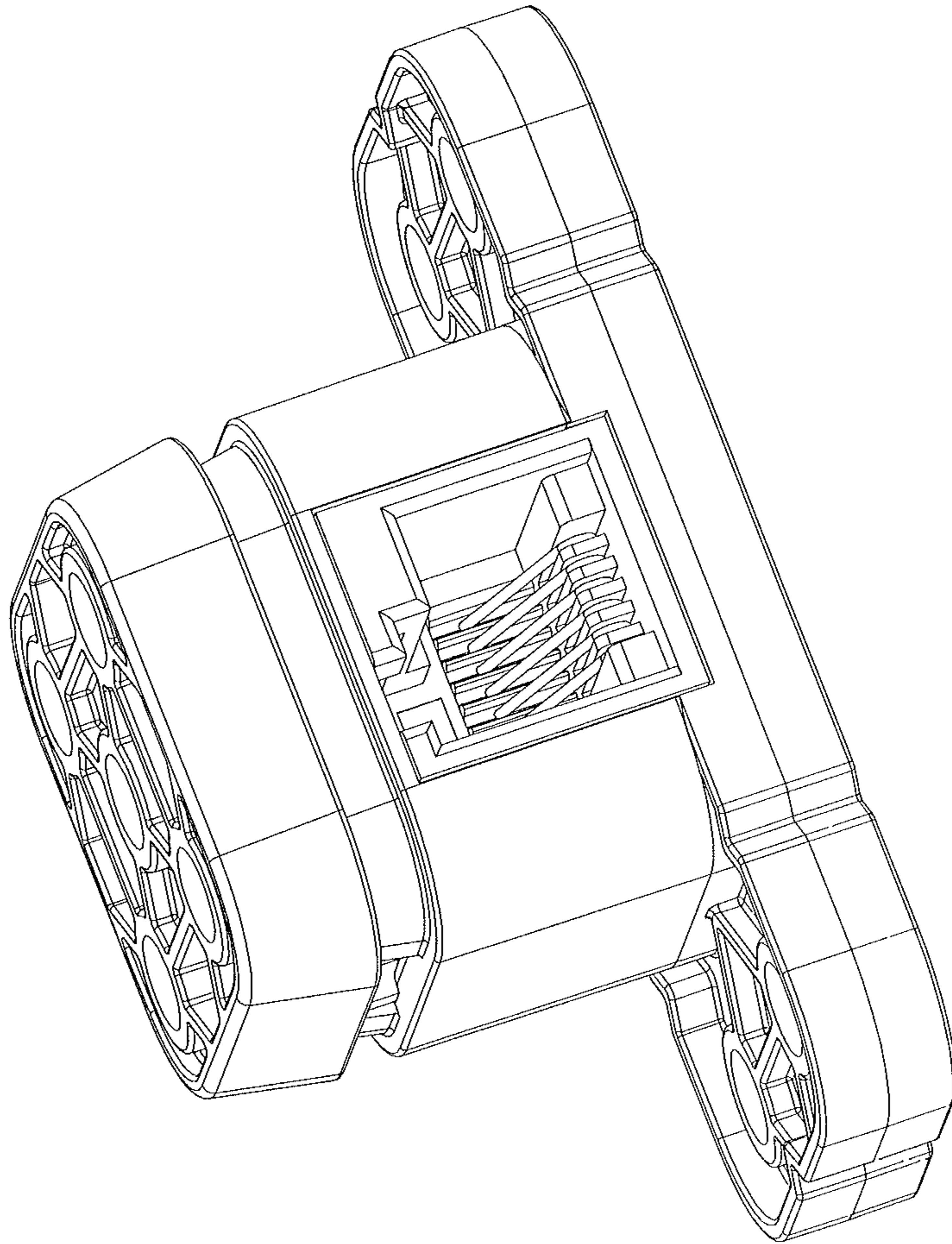

FIGURE 2

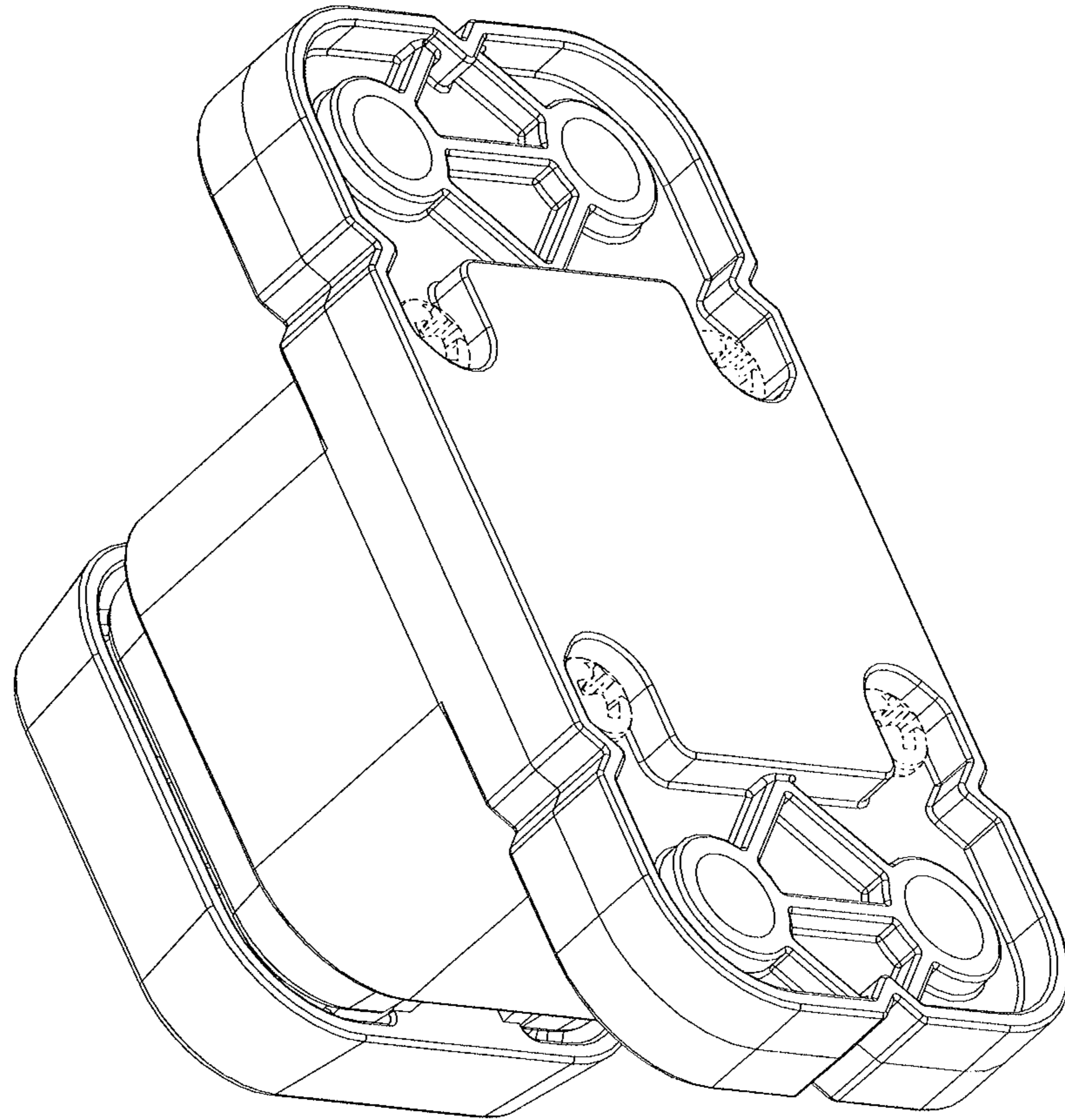

FIGURE 3

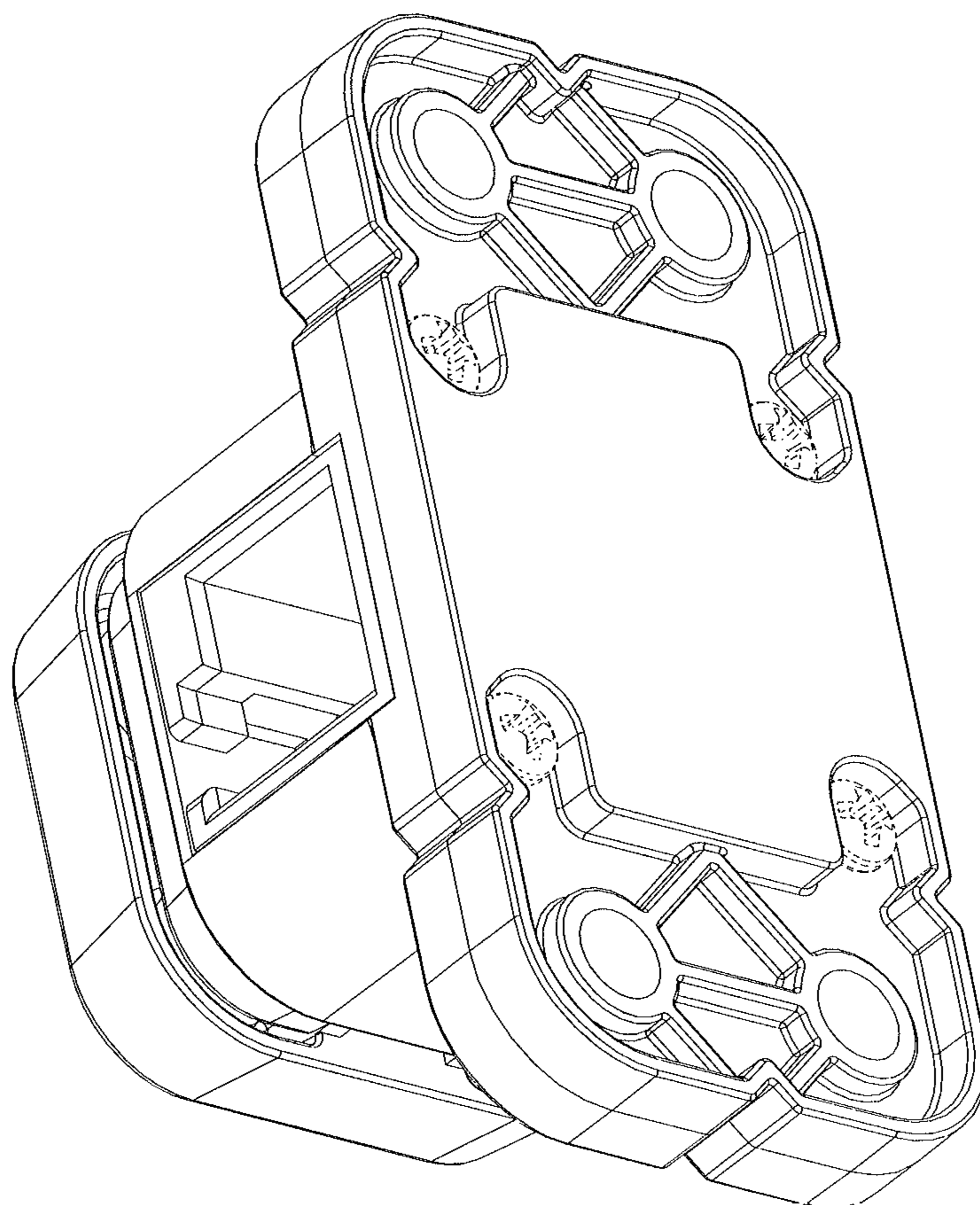

FIGURE 4

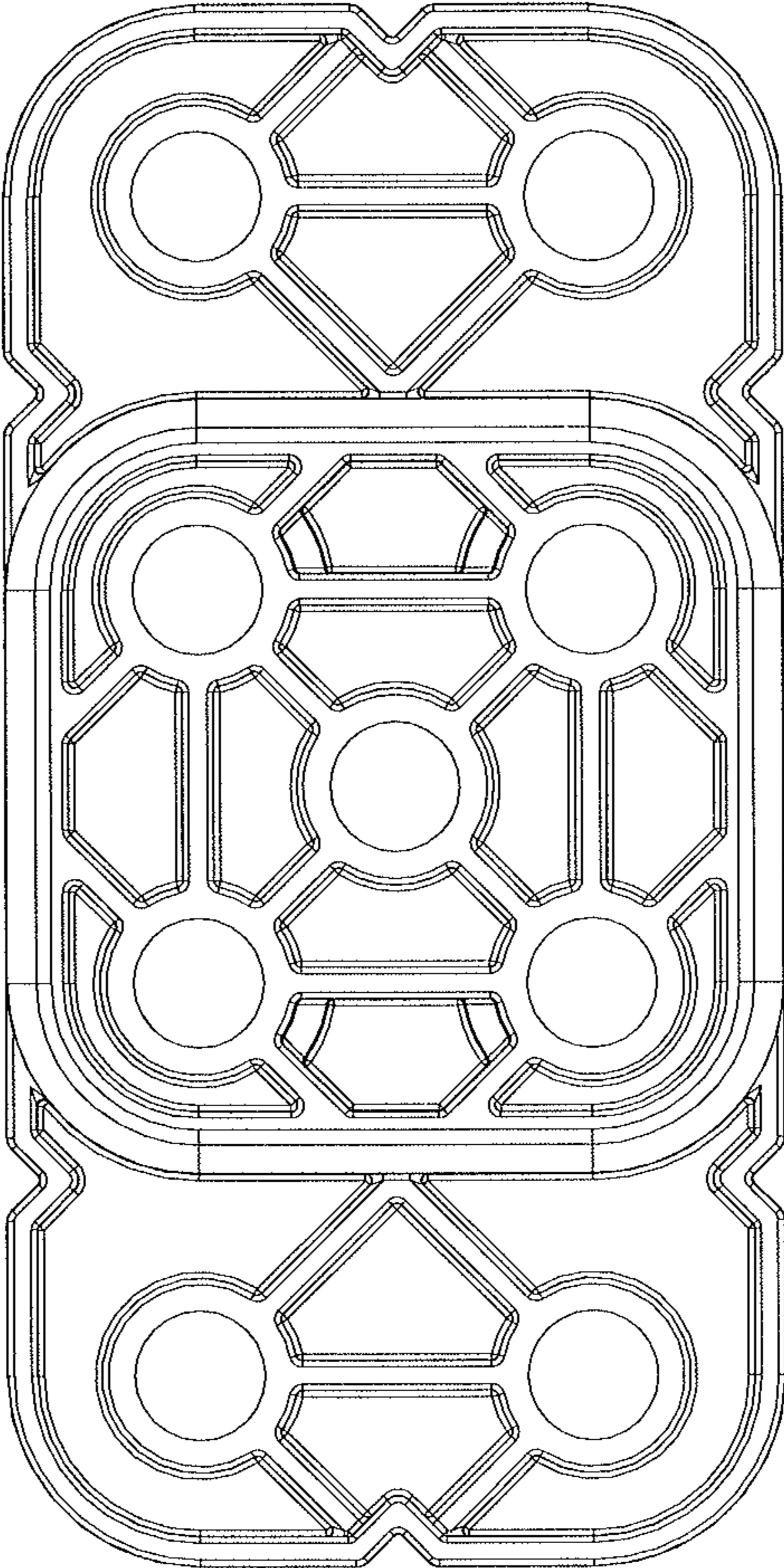

FIGURE 5

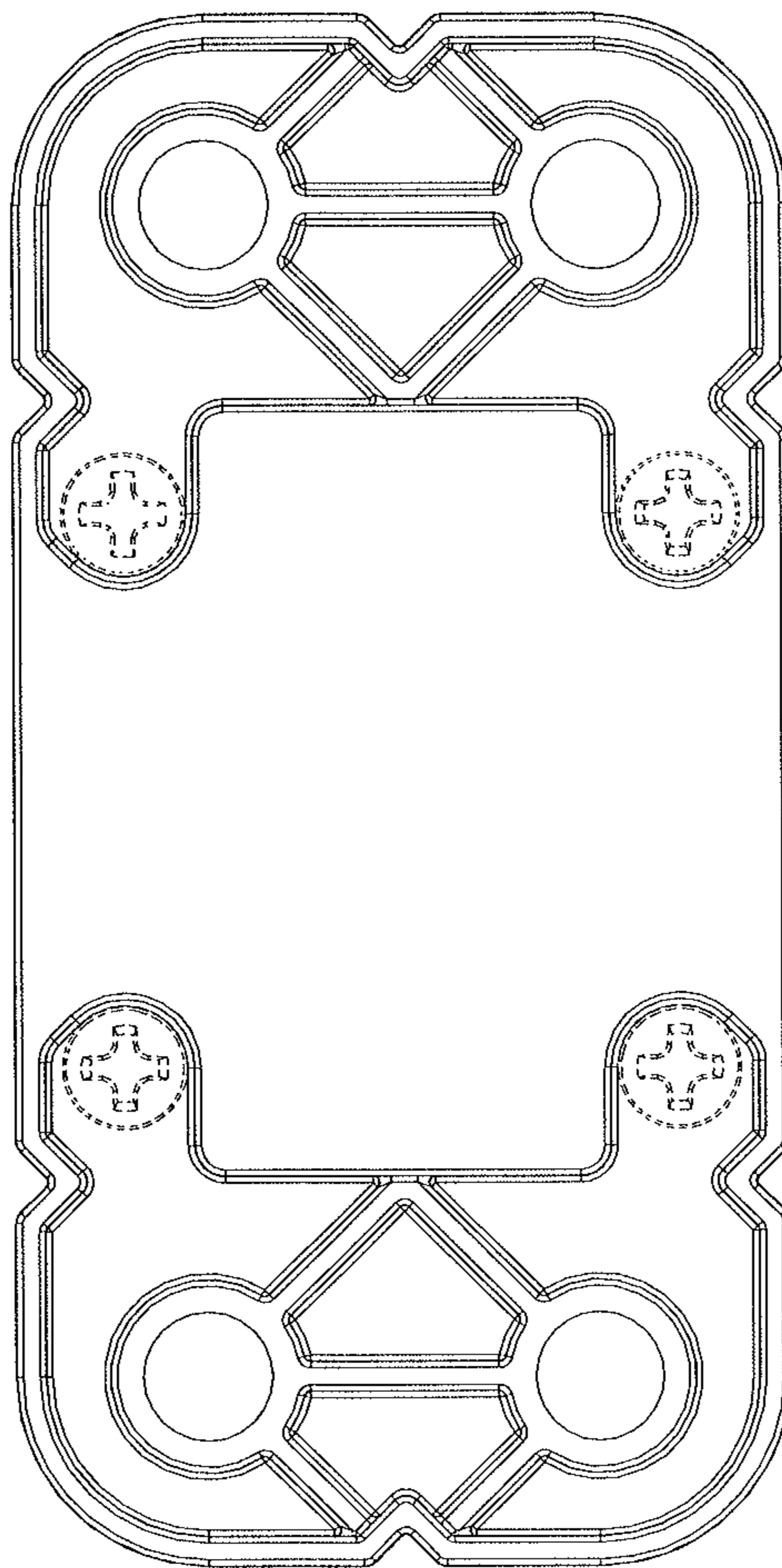

FIGURE 6

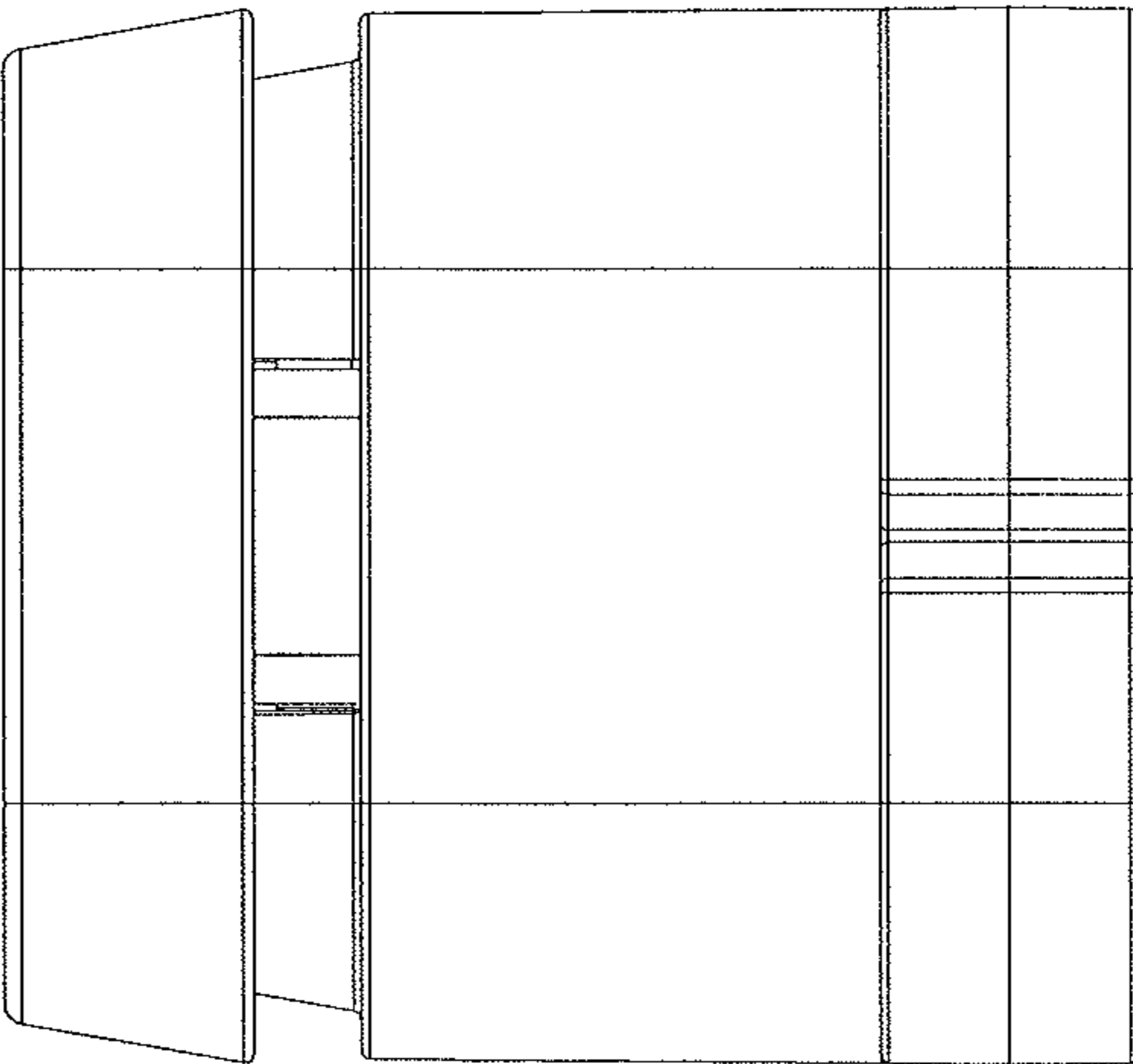

FIGURE 7

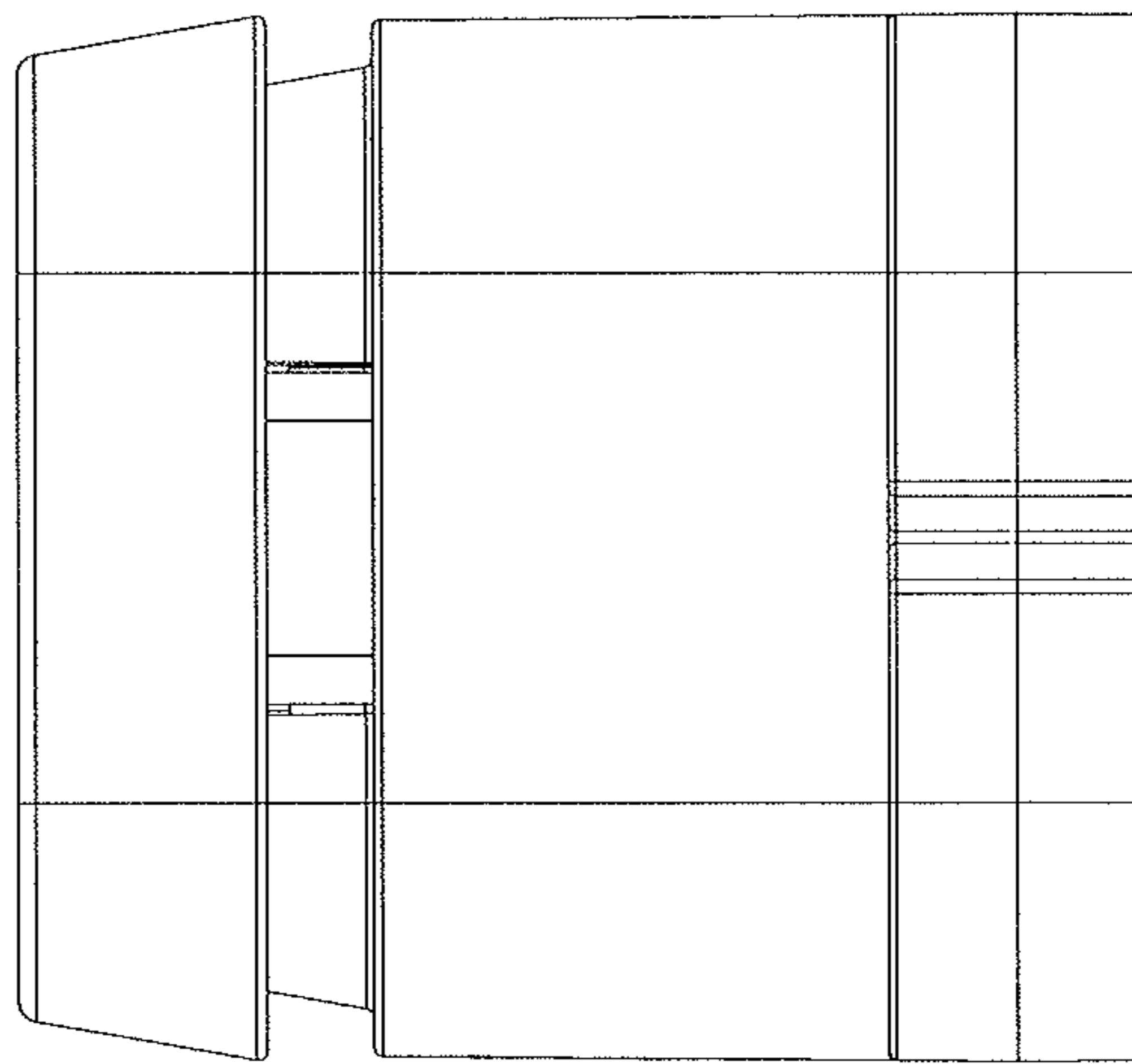

FIGURE 8

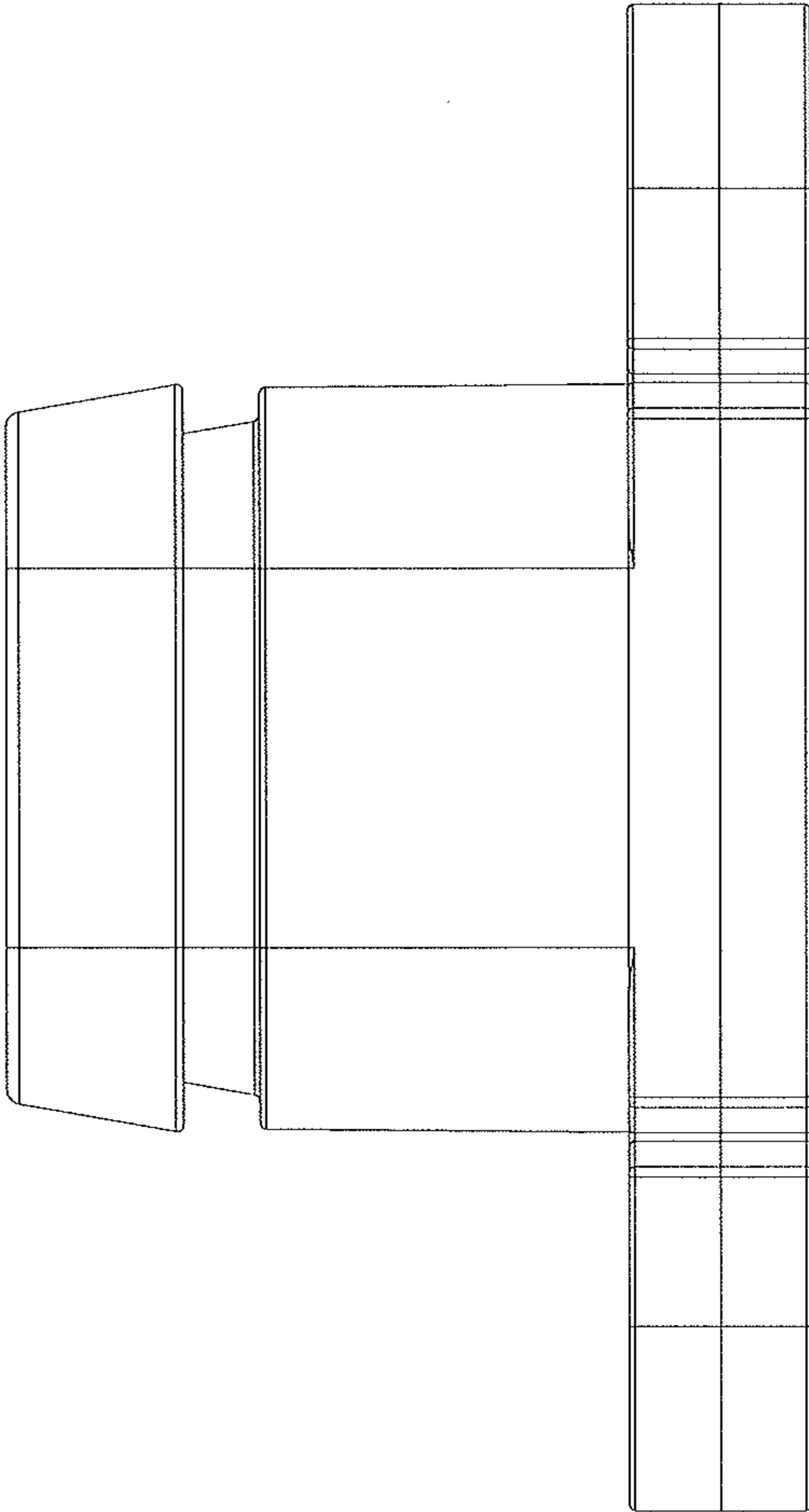

FIGURE 9

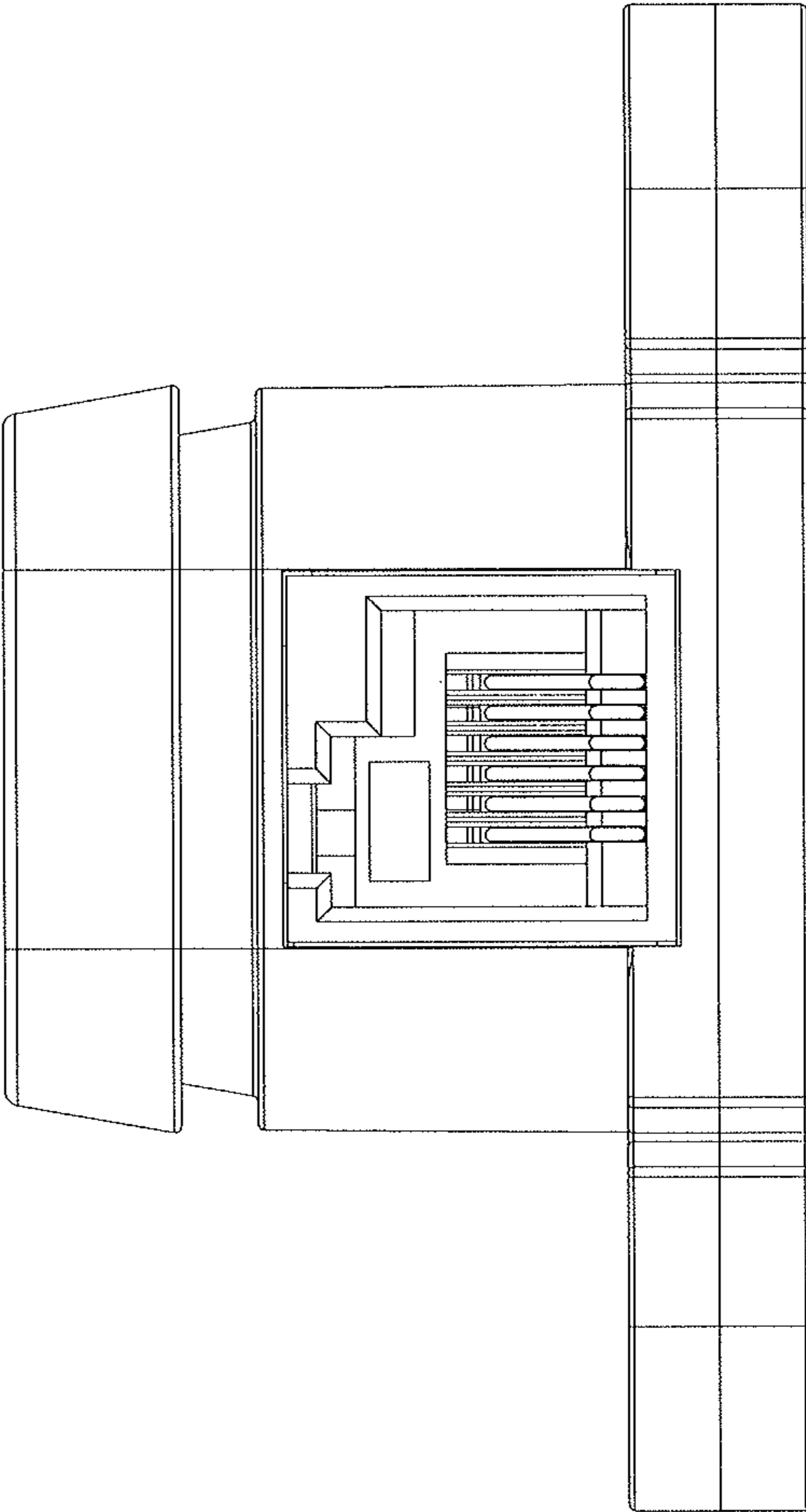

FIGURE 10