



US00D740359S

(12) **United States Design Patent**  
**So et al.**

(10) **Patent No.:** **US D740,359 S**  
(45) **Date of Patent:** **\*\* Oct. 6, 2015**

(54) **PRINTER**

(71) Applicant: **Samsung Electronics Co., Ltd.**,  
Suwon-si (KR)

(72) Inventors: **Kwang-Hyuck So**, Seoul (KR);  
**Kyong-Hwan Kim**, Seoul (KR);  
**Seung-Wook Jeong**, Seoul (KR)

(73) Assignee: **Samsung Electronics Co., Ltd.**,  
Suwon-si (KR)

(\*\*) Term: **14 Years**

(21) Appl. No.: **29/473,866**

(22) Filed: **Nov. 26, 2013**

(30) **Foreign Application Priority Data**

Jul. 3, 2013 (KR) ..... 30-2013-0034115

(51) **LOC (10) Cl.** ..... **14-02**

(52) **U.S. Cl.**  
USPC ..... **D18/55**

(58) **Field of Classification Search**  
USPC ..... D18/6-7, 14, 19, 50, 54.1, 54, 55;  
D14/420-426, 462-470; 400/613,  
400/613.1-613.4, 690.1-690.4, 691-694

See application file for complete search history.

(56) **References Cited**

U.S. PATENT DOCUMENTS

D379,196	S	*	5/1997	Laidlaw	.....	D18/55
D633,139	S	*	2/2011	Park et al.	.....	D18/55
D647,132	S	*	10/2011	Kim et al.	.....	D18/55
D685,412	S	*	7/2013	Jihoon et al.	.....	D18/50
D693,873	S	*	11/2013	Fukasawa et al.	.....	D18/55
D697,964	S	*	1/2014	Fukasawa et al.	.....	D18/55
D697,965	S	*	1/2014	Fukasawa et al.	.....	D18/55
D714,862	S	*	10/2014	Kim et al.	.....	D18/50
D715,852	S	*	10/2014	So et al.	.....	D18/50
D715,853	S	*	10/2014	Kim et al.	.....	D18/50

\* cited by examiner

*Primary Examiner* — Cathy A MacCormac

(74) *Attorney, Agent, or Firm* — NSIP Law

(57) **CLAIM**

The ornamental design for a printer, as shown and described.

**DESCRIPTION**

FIG. 1 is a front perspective view of a printer showing our new design;

FIG. 2 is a front view thereof;

FIG. 3 is a rear view thereof;

FIG. 4 is a left-side view thereof;

FIG. 5 is a right-side view thereof;

FIG. 6 is a top view thereof; and,

FIG. 7 is a bottom view thereof.

The broken lines are for environmental purposes only and form no part of the claimed design.

**1 Claim, 4 Drawing Sheets**

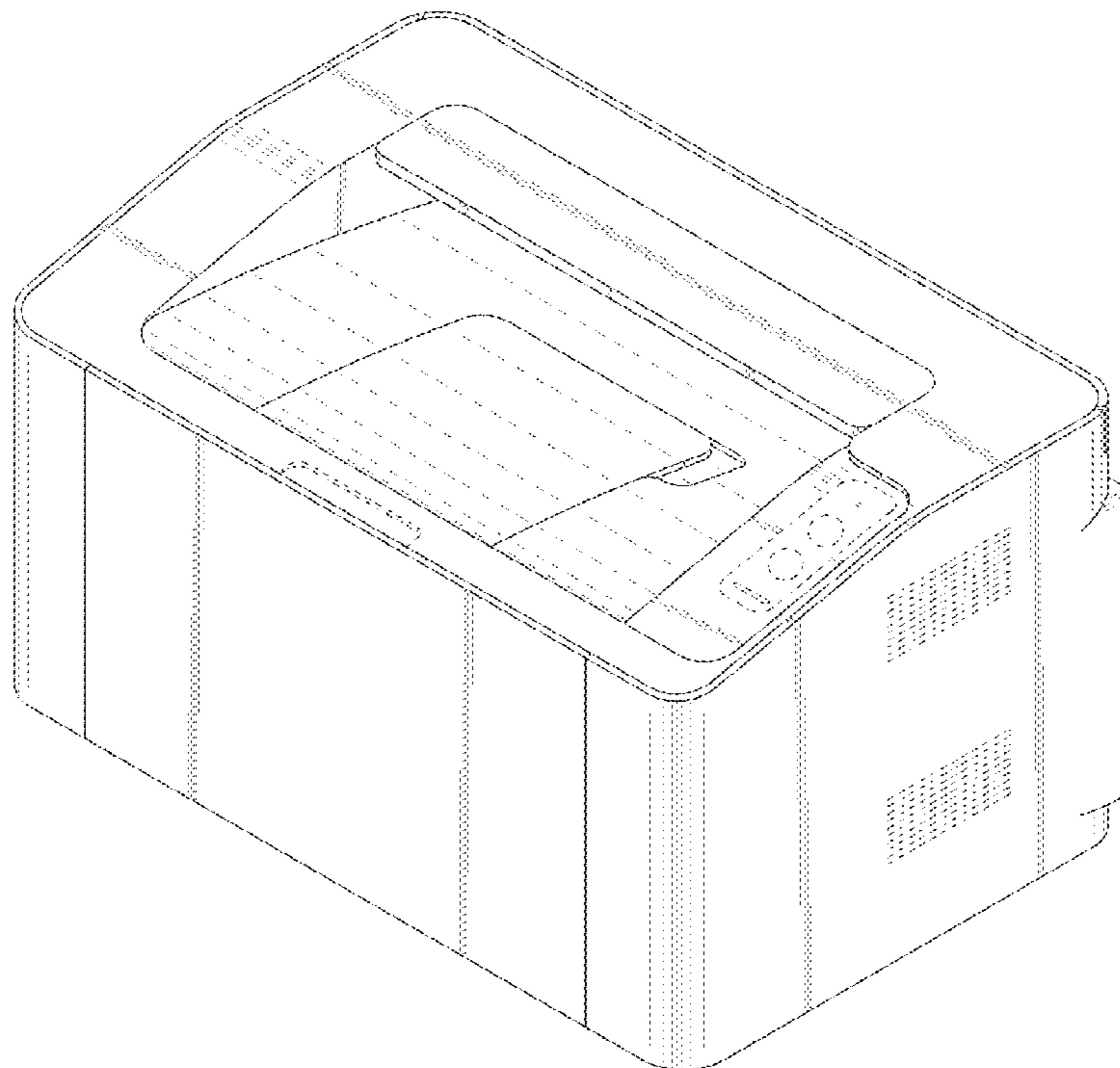

FIG. 1

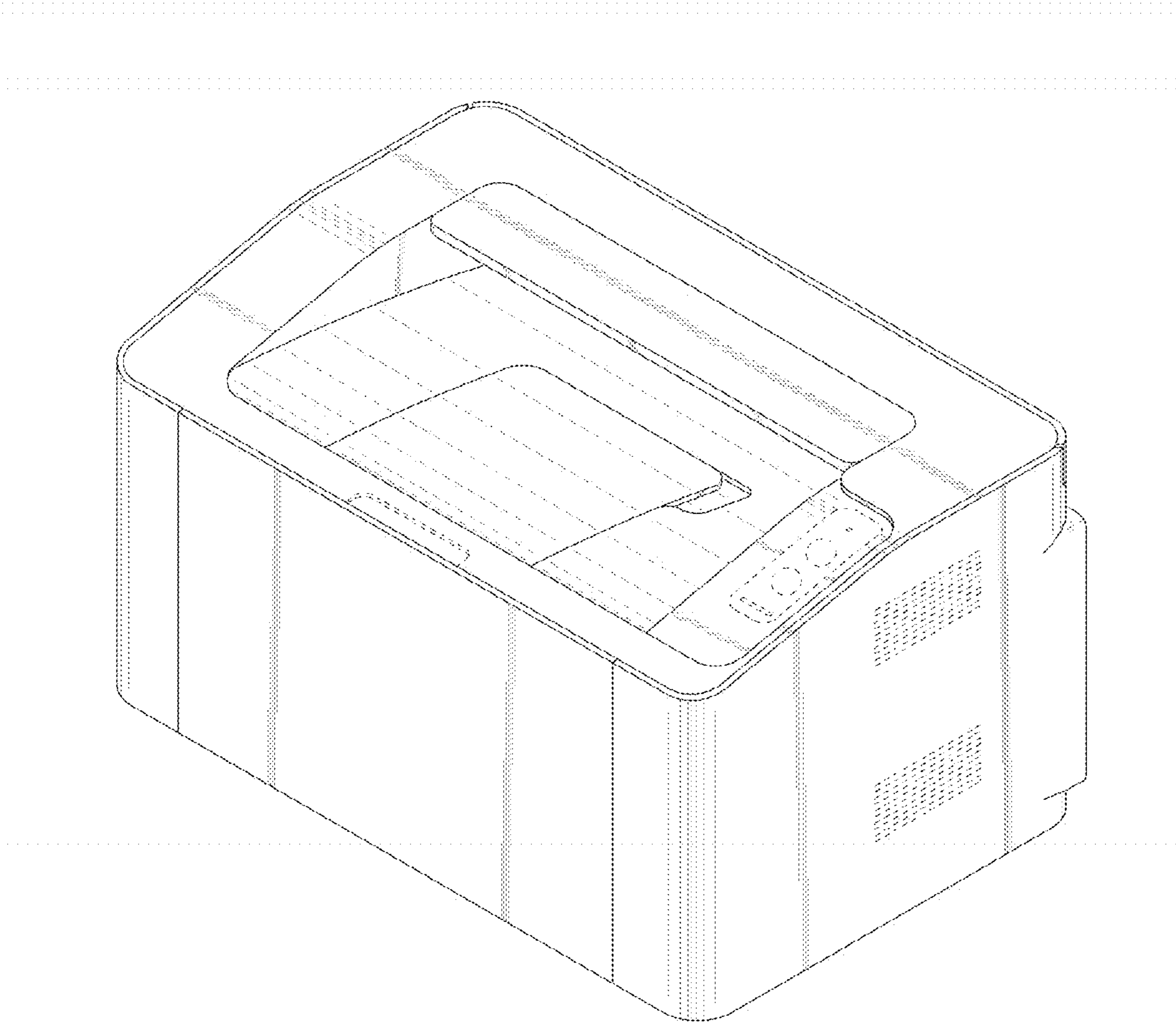

FIG.2

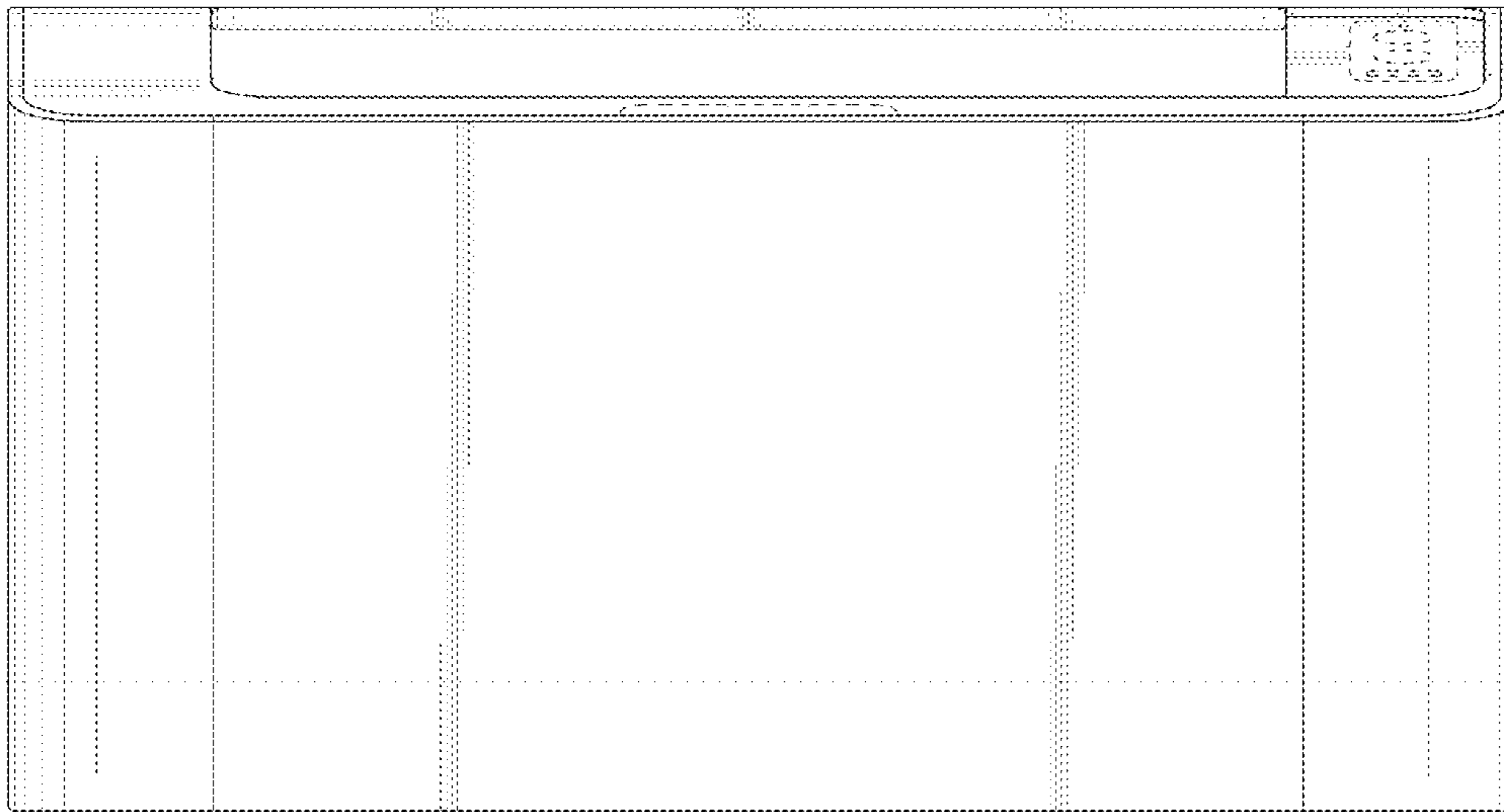

FIG.3

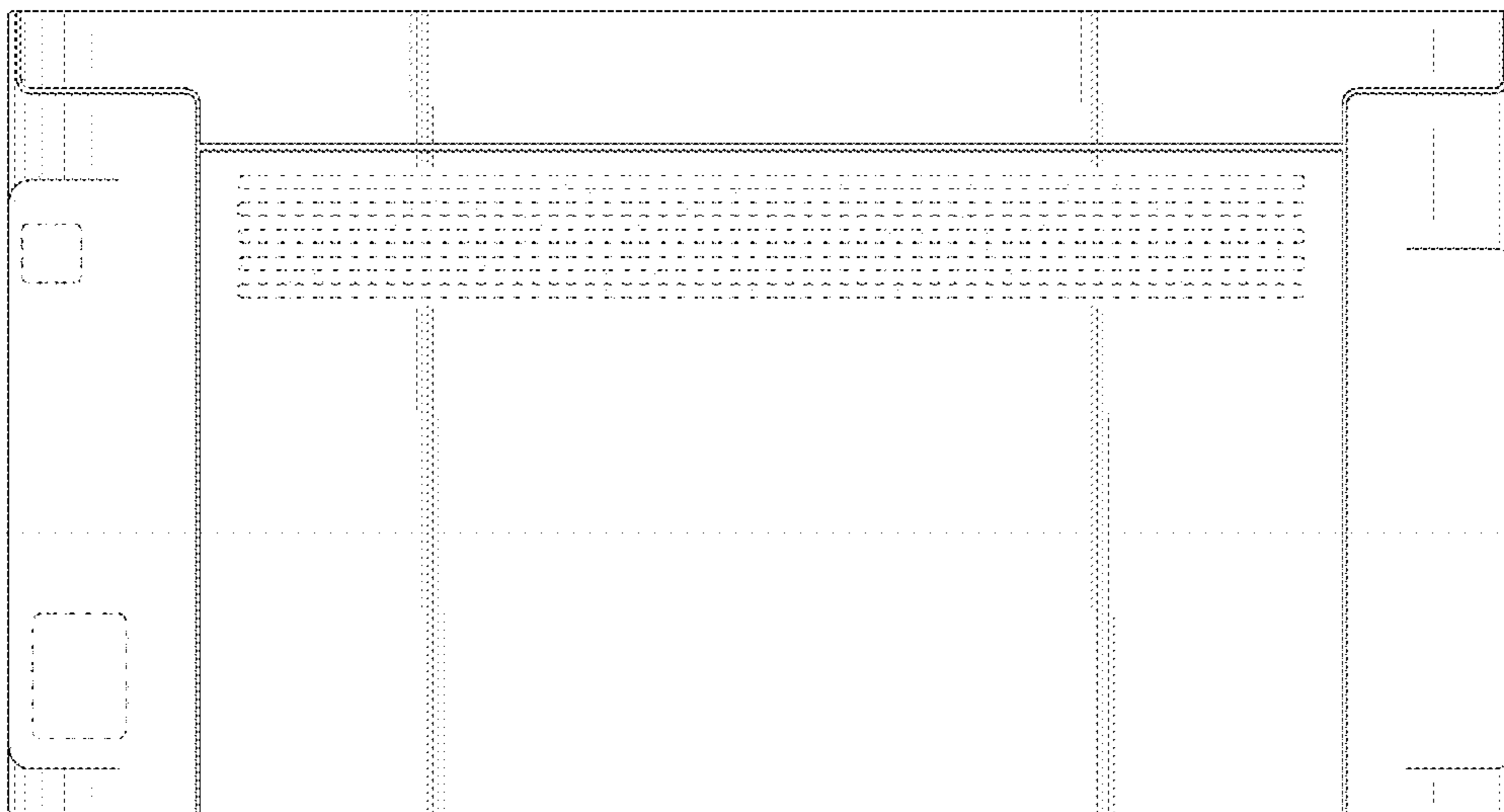

FIG.4

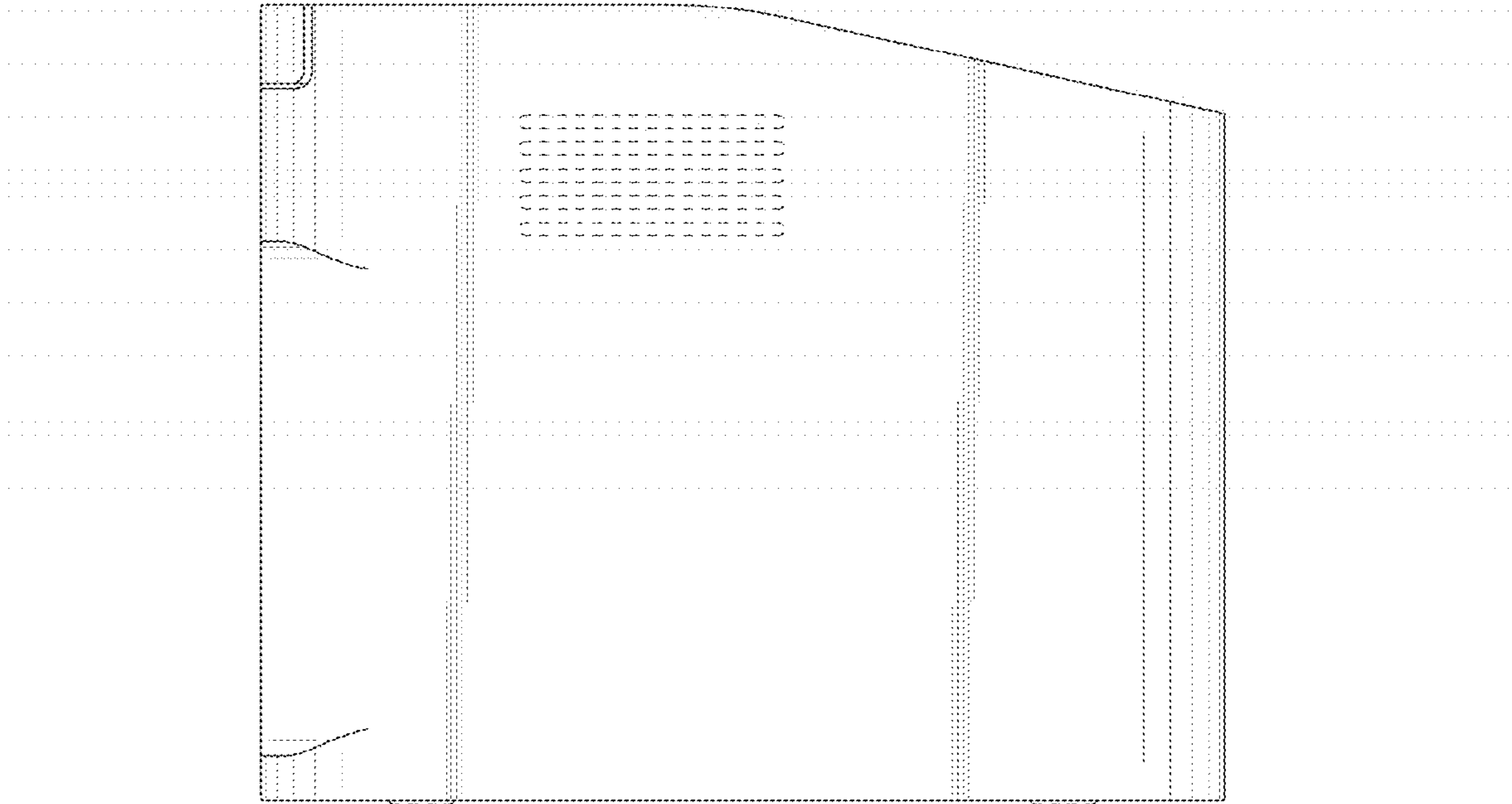

FIG.5

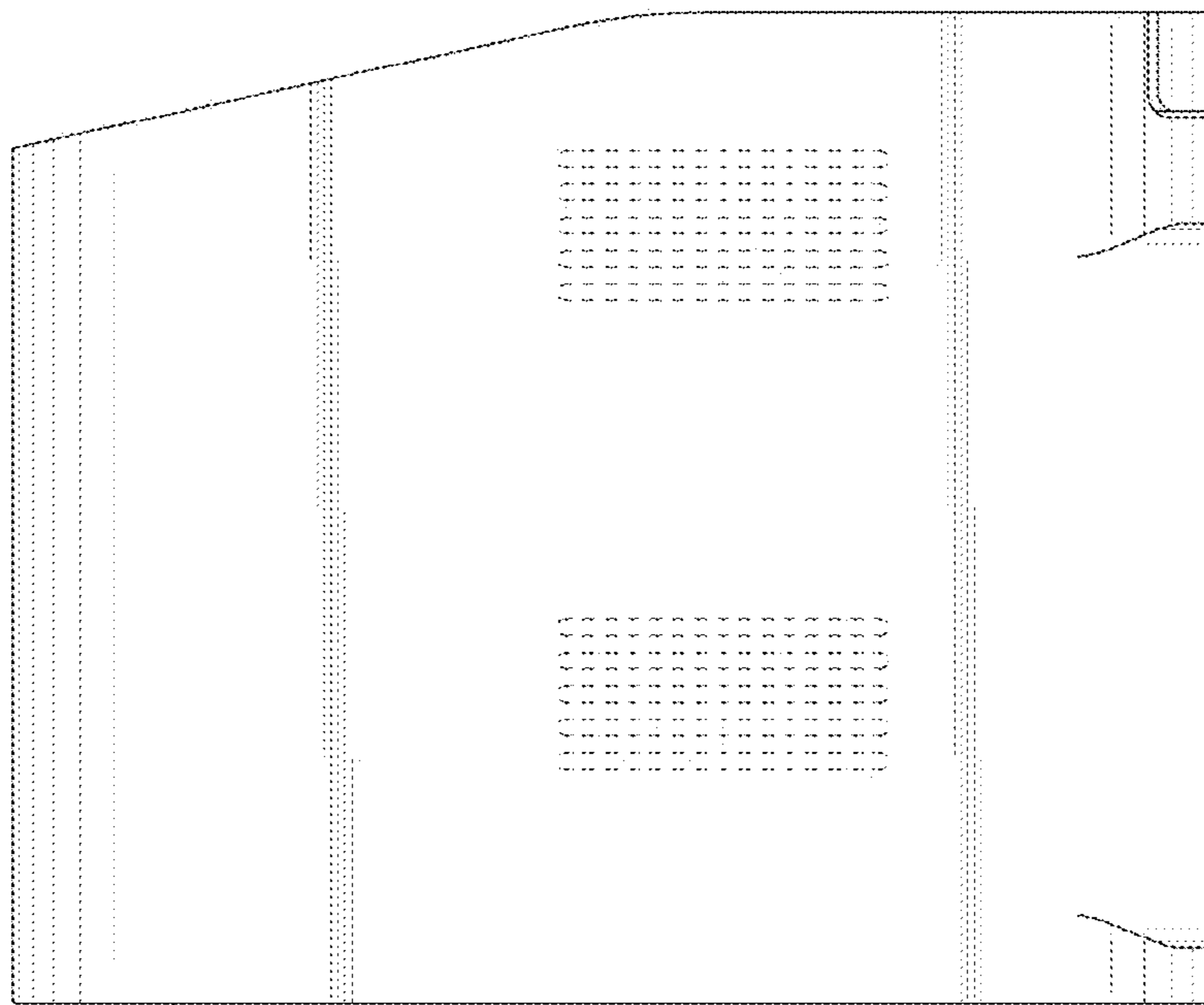



FIG.6

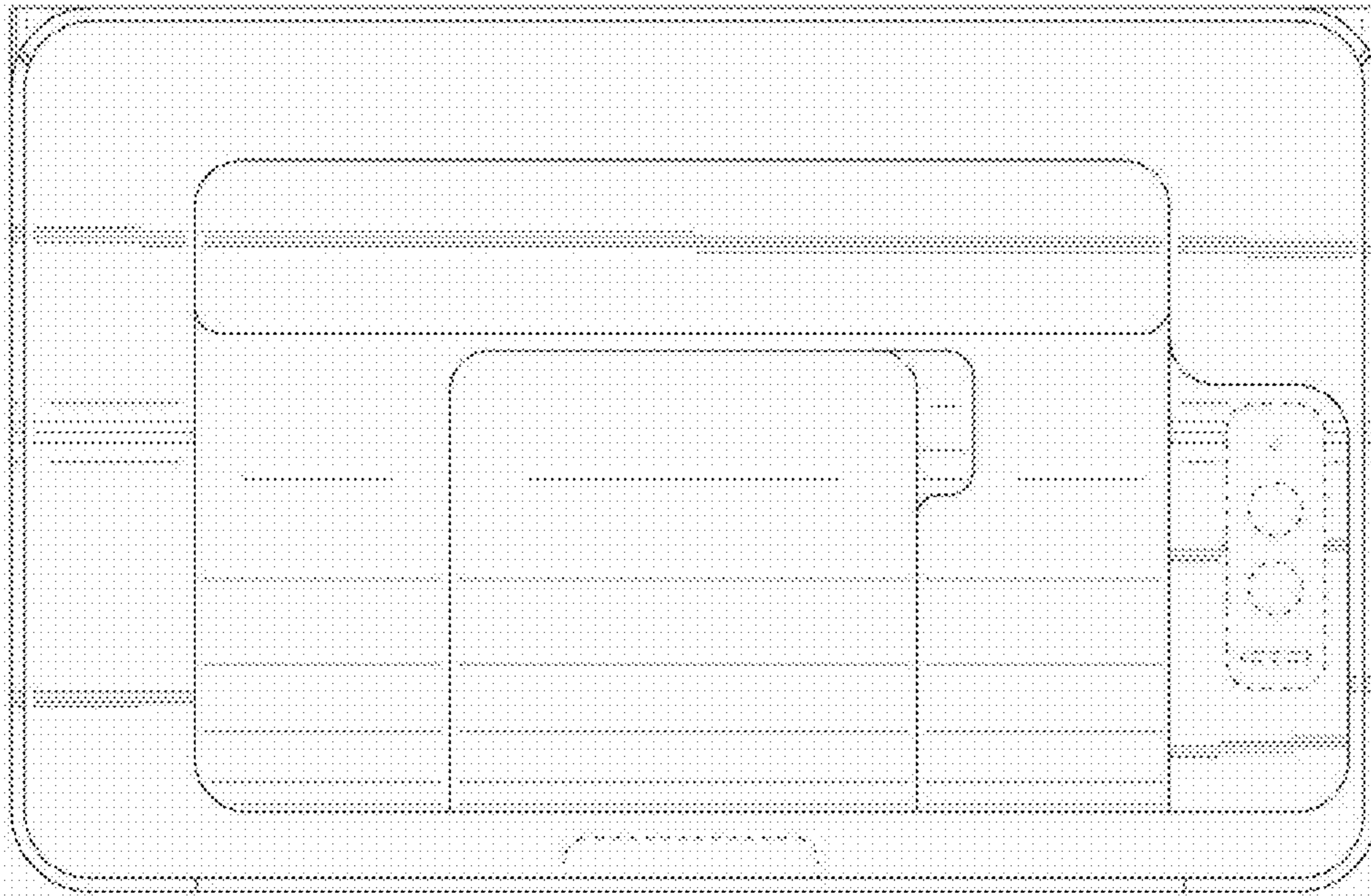

FIG.7

