



US00D740353S

(12) **United States Design Patent**
Hummel

(10) **Patent No.:** **US D740,353 S**
(45) **Date of Patent:** **** Oct. 6, 2015**

(54) **TONE EFFECTS PEDAL**

(71) Applicant: **Markus Oliver Hummel**, San Jose, CA
(US)

(72) Inventor: **Markus Oliver Hummel**, San Jose, CA
(US)

(**) Term: **14 Years**

(21) Appl. No.: **29/483,616**

(22) Filed: **Feb. 28, 2014**

(51) **LOC (10) Cl.** **17-03**

(52) **U.S. Cl.**
USPC **D17/20**

(58) **Field of Classification Search**
USPC D17/18, 19, 20, 99, 13; D21/567, 570,
D21/573, 574, 575; D22/103, 108, 100,
D22/101, 199
CPC G10H 1/342; G10H 1/0091; G10H 1/32;
G10H 3/186; G10H 3/00; G10H 1/02; F41B
11/52; F41B 11/51; F41B 11/55; F41A 9/62
See application file for complete search history.

(56) **References Cited**

U.S. PATENT DOCUMENTS

5,973,256	A *	10/1999	Martinez	84/653
6,043,422	A *	3/2000	Chapman	84/723
7,297,863	B2 *	11/2007	May	84/723
7,355,110	B2 *	4/2008	Nash	84/601
8,186,086	B2 *	5/2012	Gur-Ari et al.	42/1.02
8,283,547	B2 *	10/2012	Villa et al.	84/609
D680,611	S *	4/2013	Emde et al.	D22/103
8,485,405	B2 *	7/2013	Crye	224/666
2007/0013539	A1 *	1/2007	Choi et al.	340/671
2008/0295676	A1 *	12/2008	Yamada	84/741
2015/0013526	A1 *	1/2015	Packouz et al.	84/603
2015/0090096	A1 *	4/2015	Krumwiede	84/317

OTHER PUBLICATIONS

Magazines, image post date Jul. 22, 2012, site visted on Apr. 30, 2015
(online), <<http://www.cartter.net/?tag=magazines>>.*

* cited by examiner

Primary Examiner — Sheryl Lane
Assistant Examiner — Ieisha Price

(57) **CLAIM**

The ornamental design for a tone effects pedal, as shown and described.

DESCRIPTION

FIG. 1 is an exploded perspective view of a tone effects pedal in detached position;
FIG. 2 is an exploded front elevational view thereof;
FIG. 3 is an exploded rear elevational view thereof;
FIG. 4 is an exploded left side elevational view thereof;
FIG. 5 is an exploded right side elevational view thereof;
FIG. 6 is an exploded top plan view thereof;
FIG. 7 is an exploded bottom plan view thereof;
FIG. 8 is an exploded bottom perspective view thereof;
FIG. 9 is an additional exploded perspective view thereof;
FIG. 10 is a perspective view of the tone effects pedal in attached position;
FIG. 11 is a front elevational view thereof;
FIG. 12 is a rear elevational view thereof;
FIG. 13 is a left side elevational view thereof;
FIG. 14 is a right side elevational view thereof;
FIG. 15 is a top plan view thereof;
FIG. 16 is a bottom plan view thereof;
FIG. 17 is a bottom perspective view thereof;
FIG. 18 is an additional perspective view thereof;
FIG. 19 is an additional perspective view thereof; and,
FIG. 20 is an environmental perspective view of the tone effects pedal integrated into an electric guitar.
The broken lines in the drawings illustrate portions of the tone effects pedal and form no part of the claimed design. The broken line showing of the guitar, in FIG. 20, represents the environment of the claimed design and forms no part thereof.

1 Claim, 20 Drawing Sheets

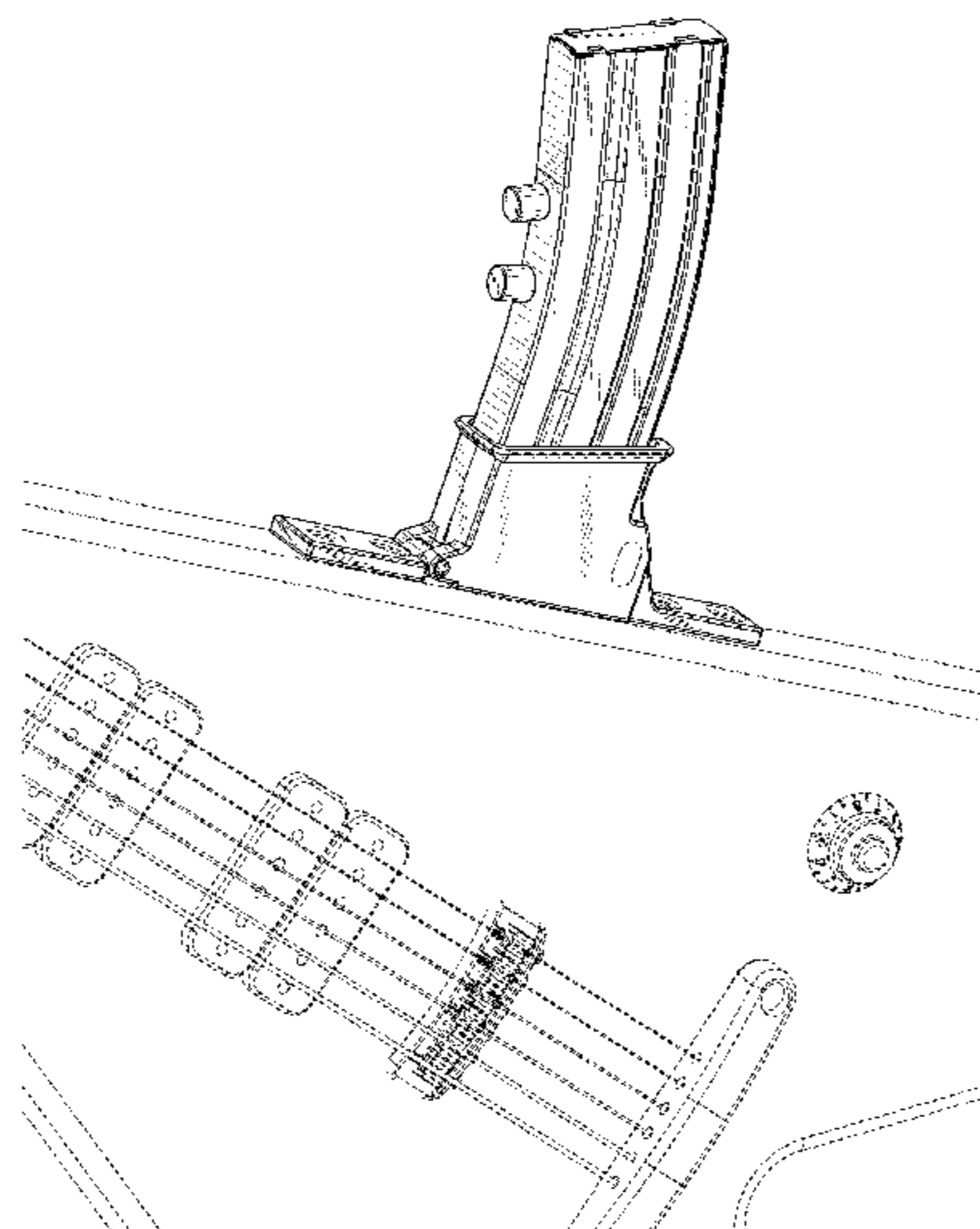

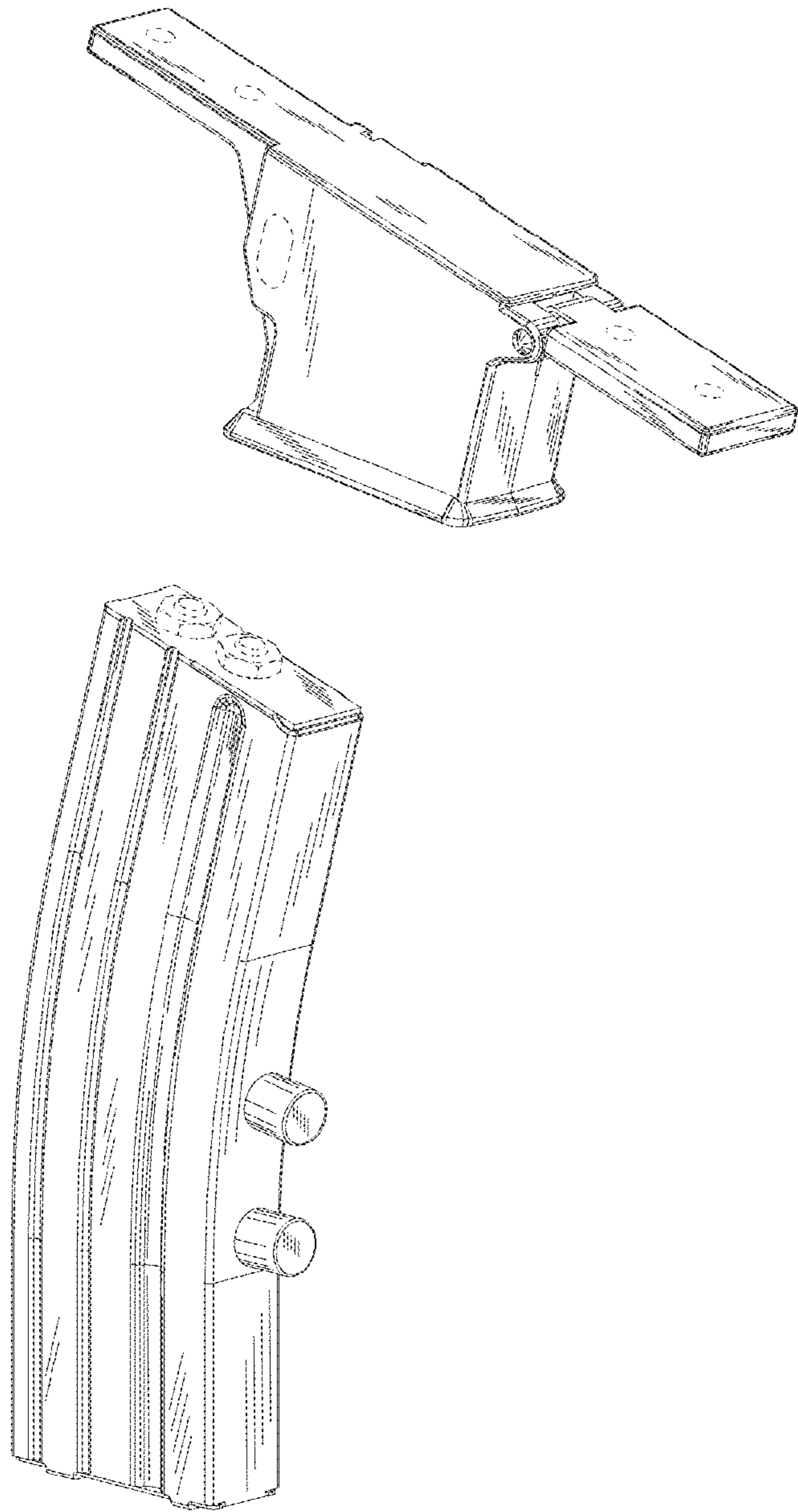

FIG. 1

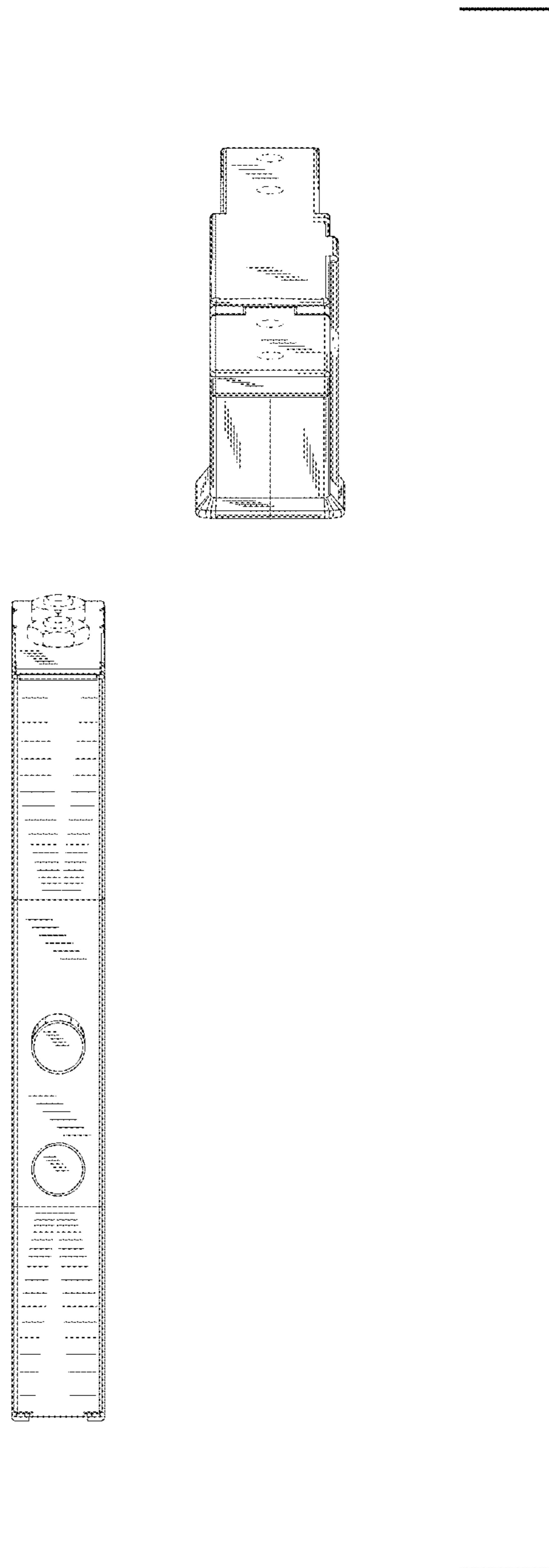

FIG. 2

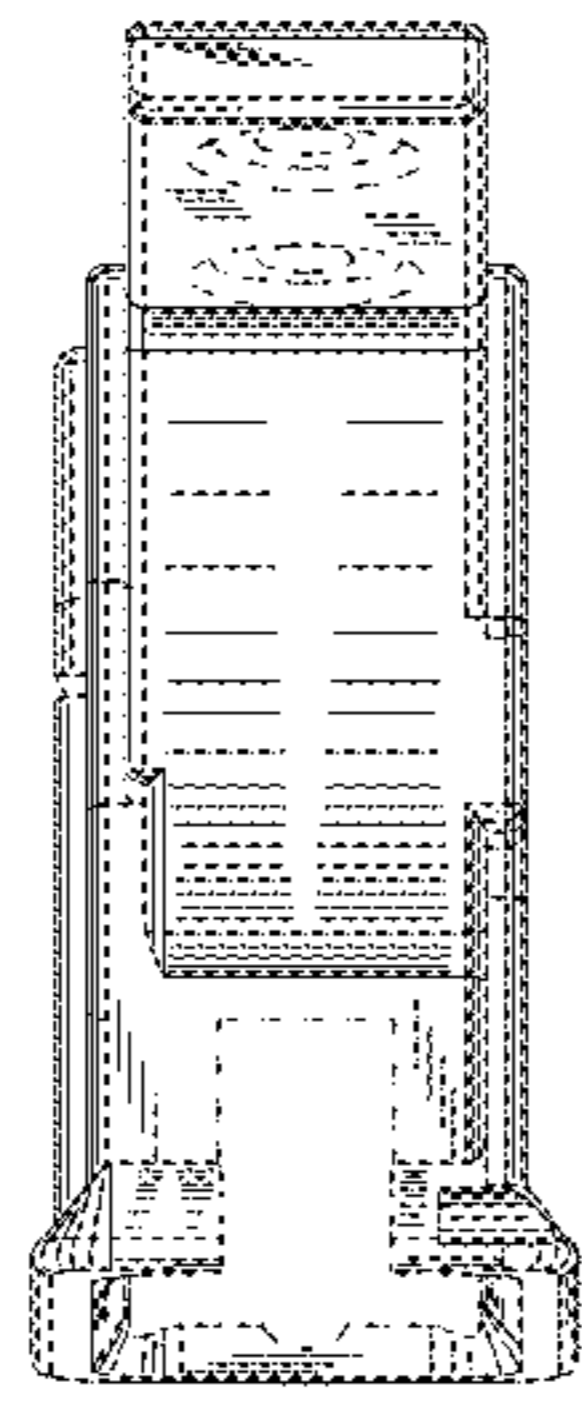

FIG. 3

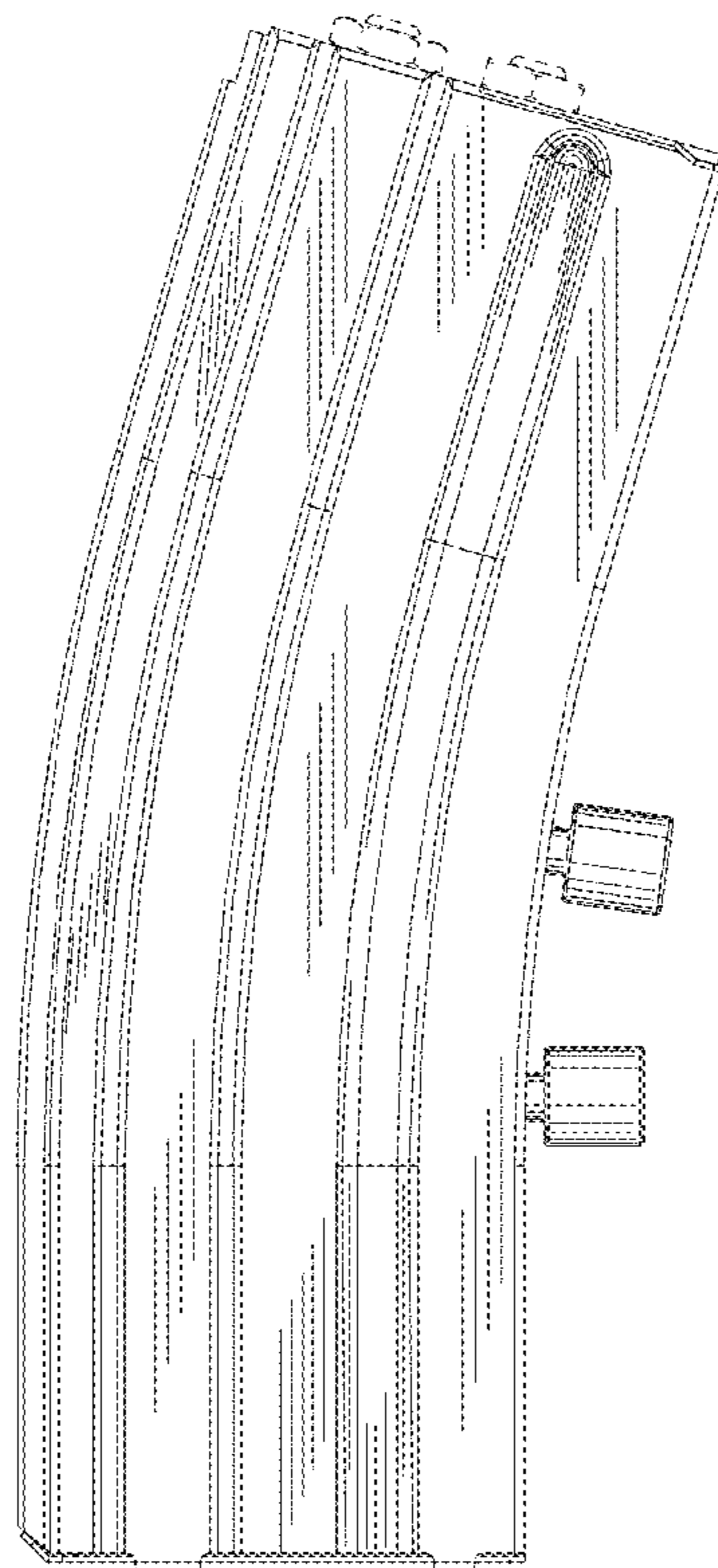
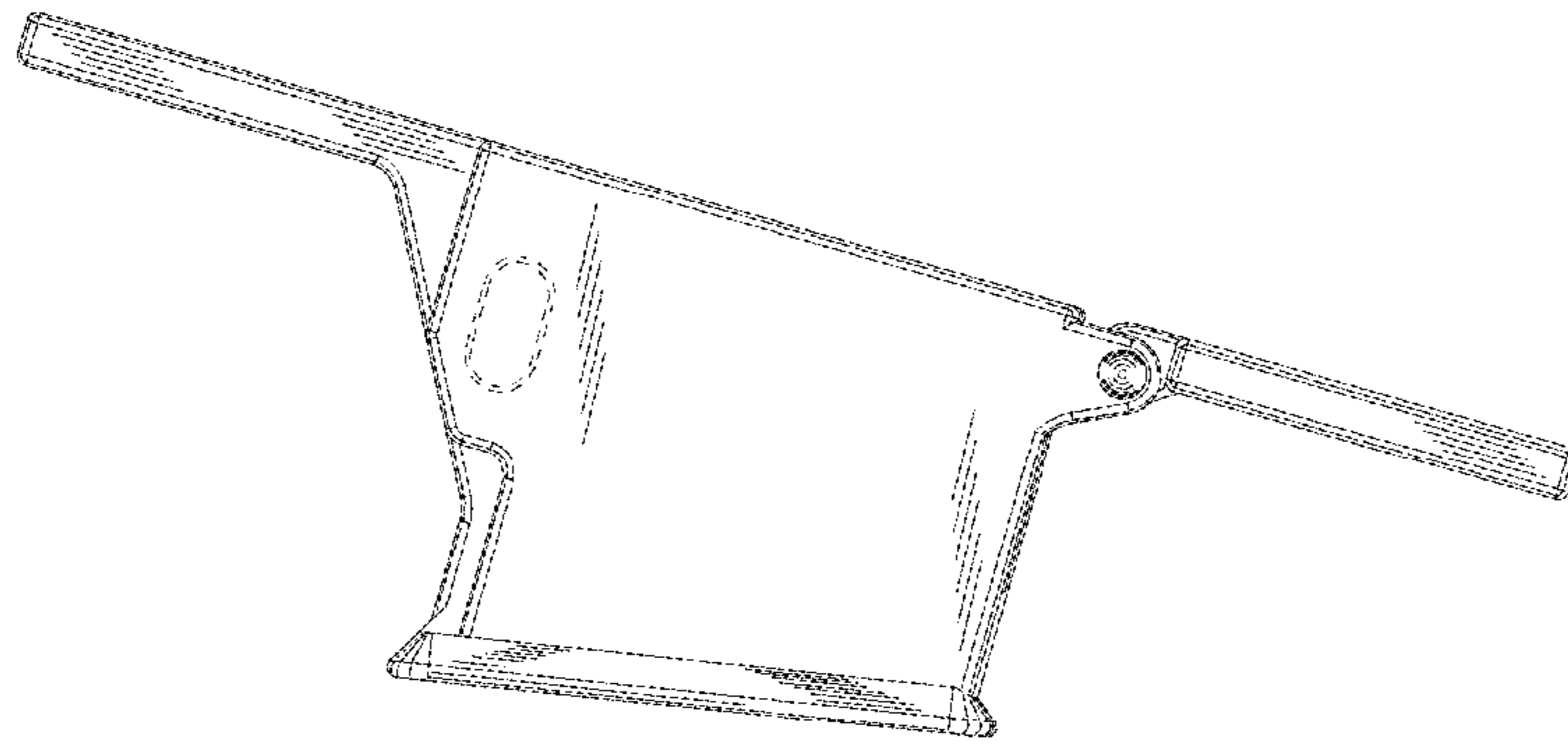

FIG. 4

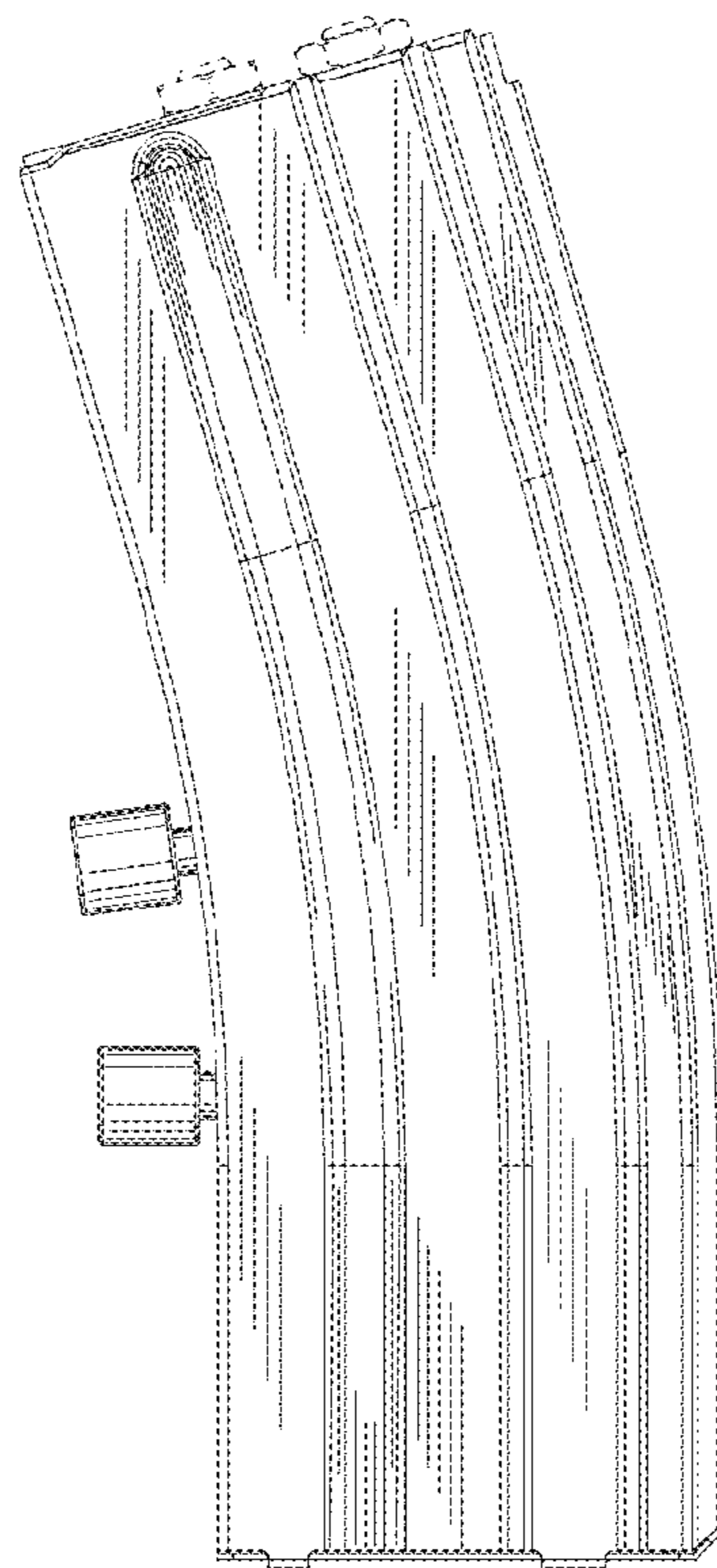
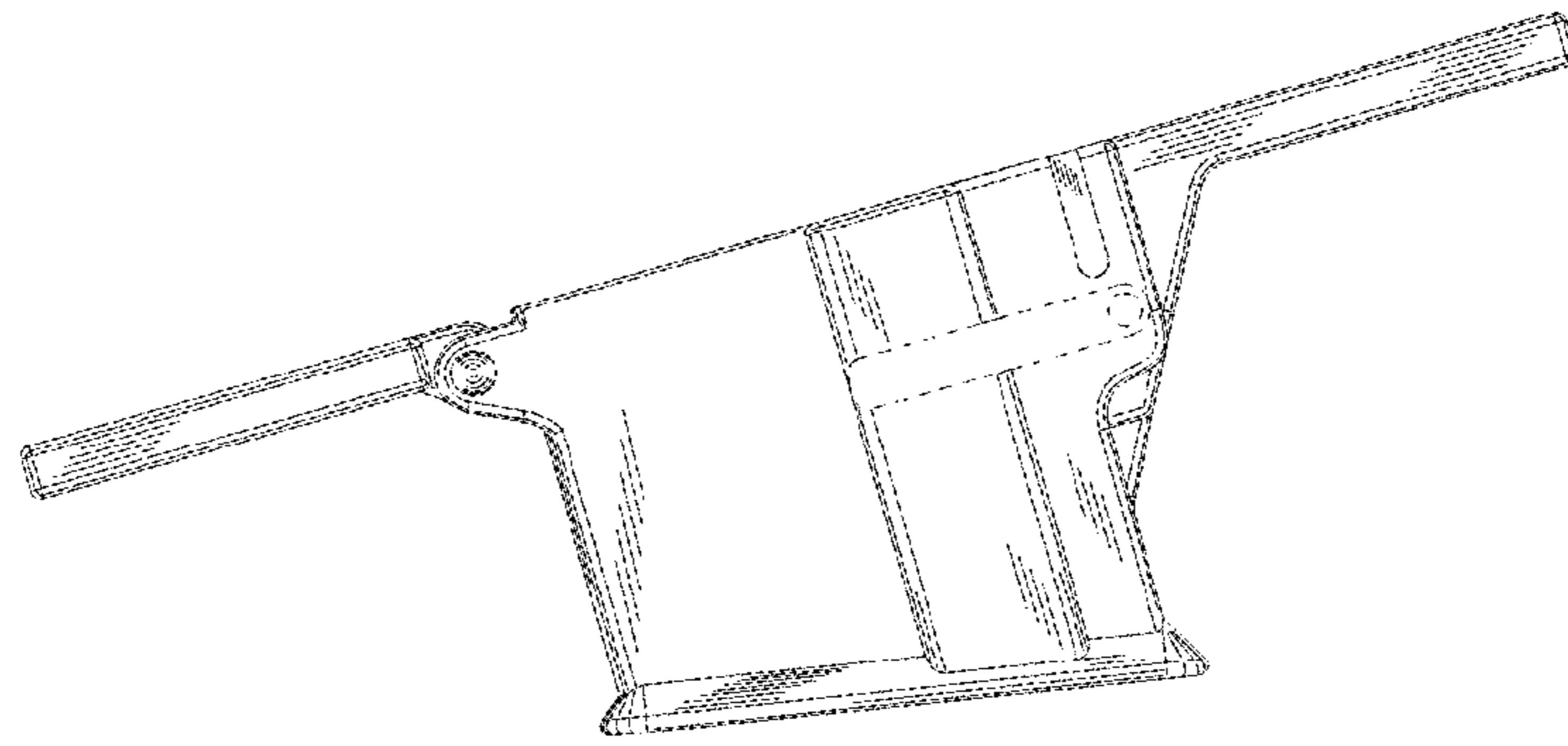

FIG. 5

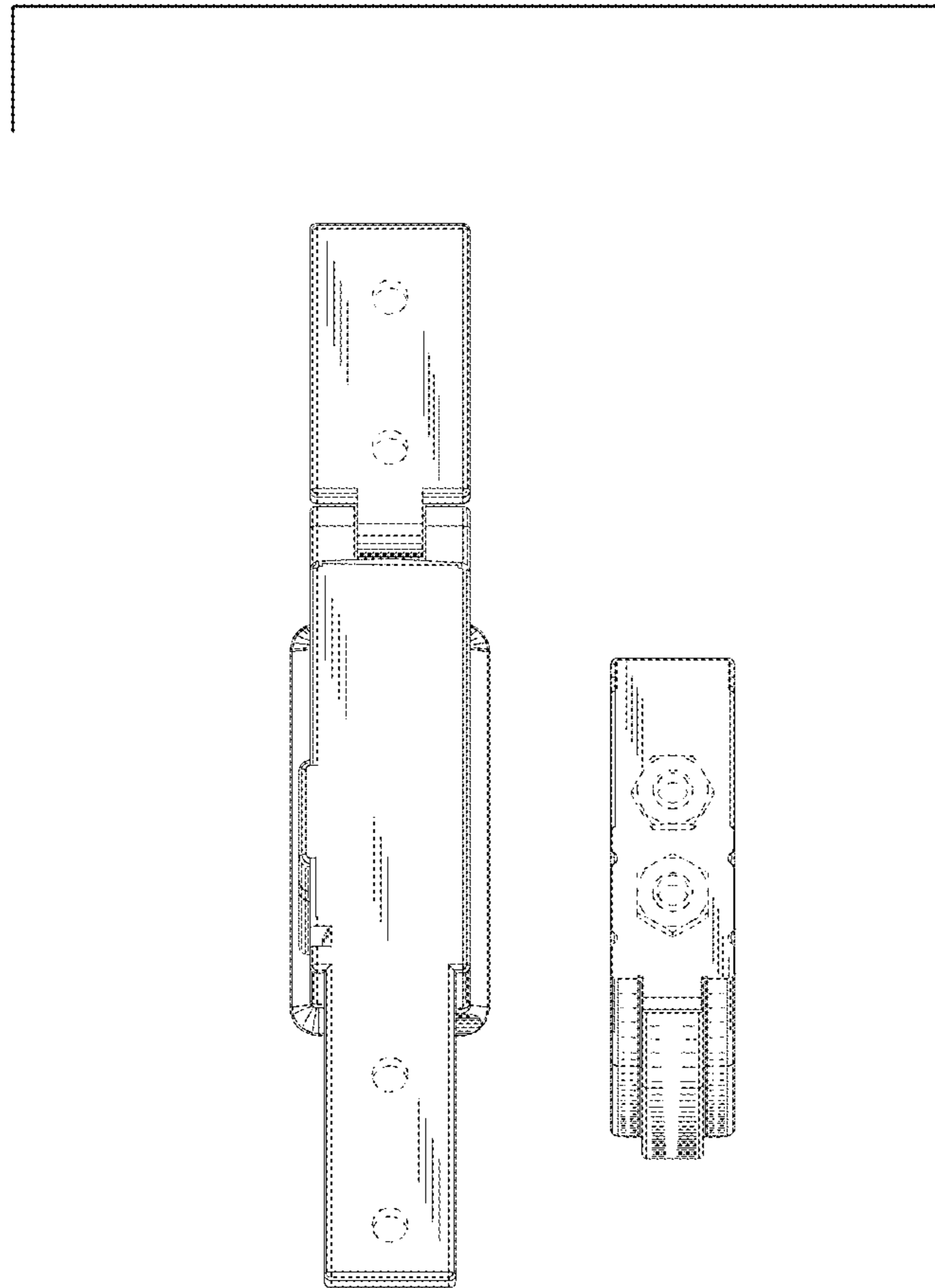

FIG. 6

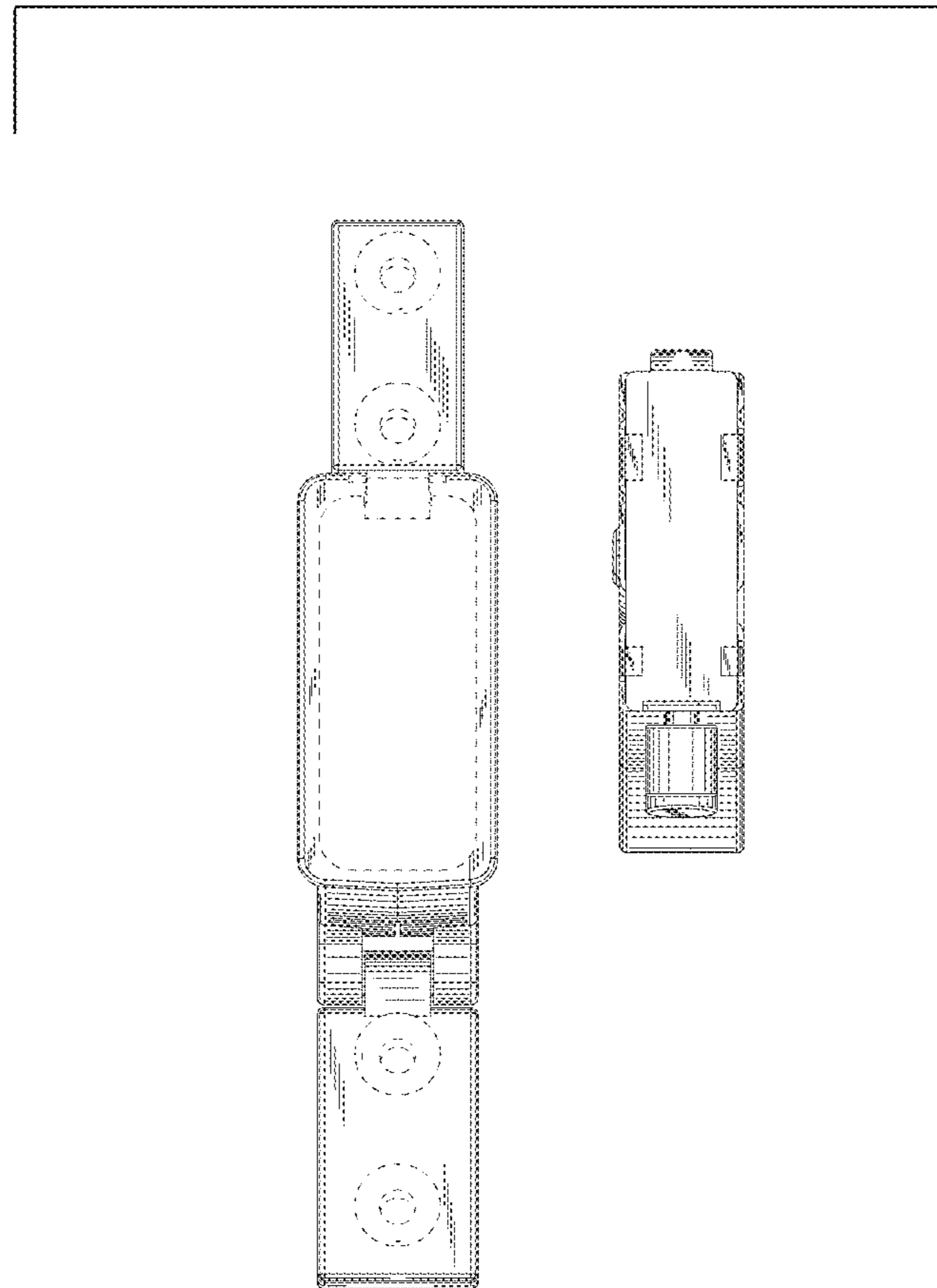

FIG. 7

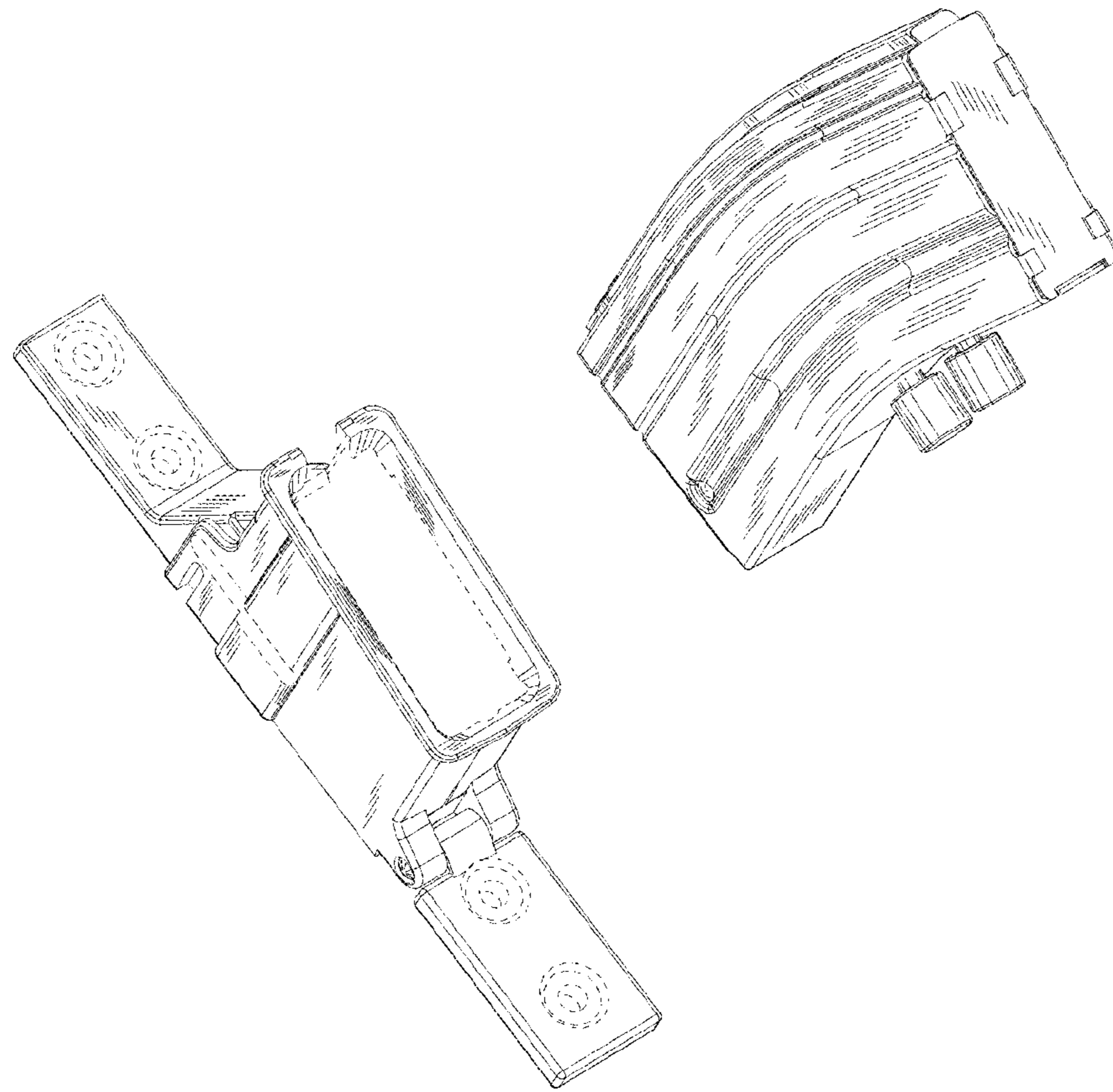

FIG. 8

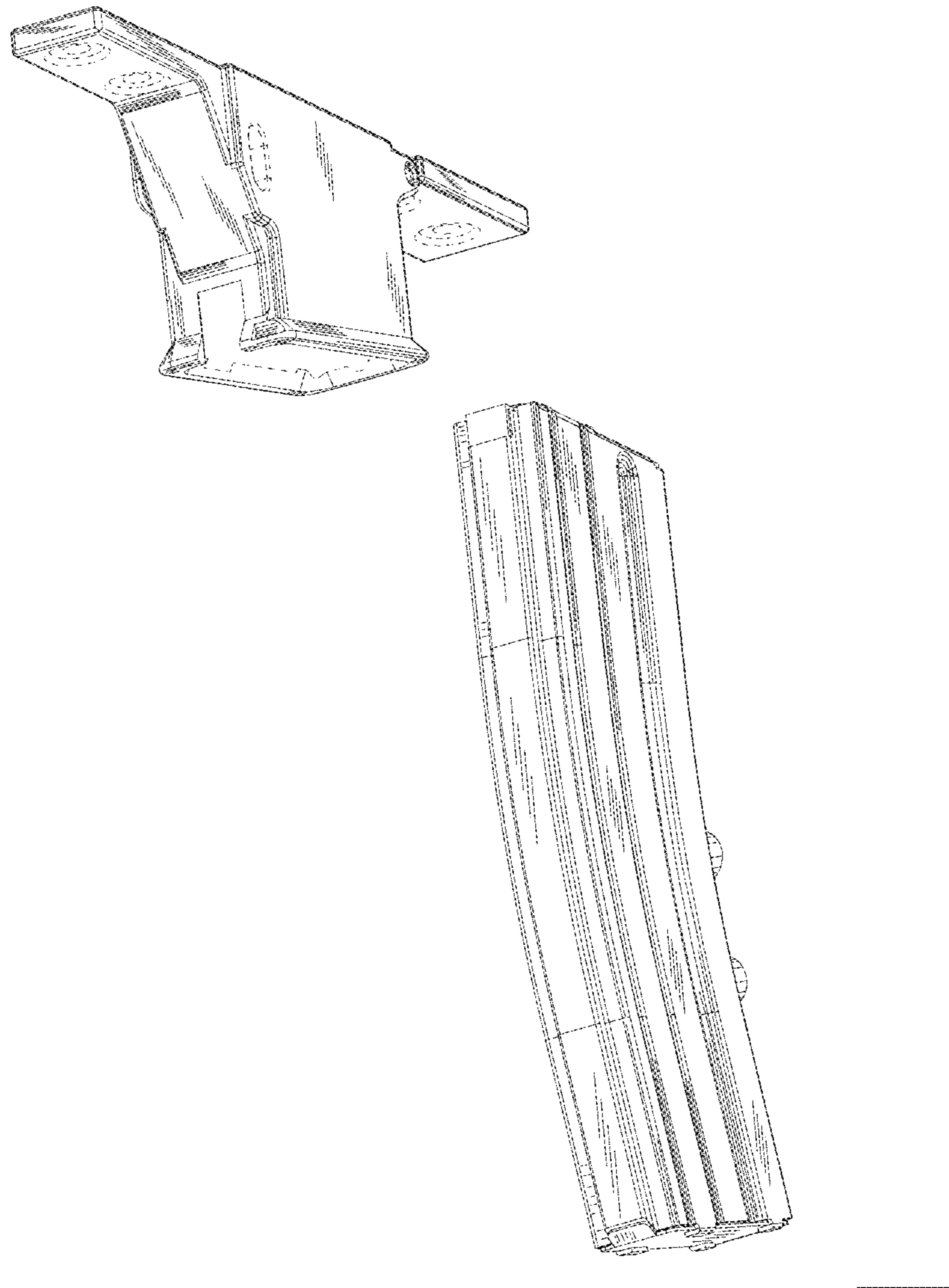

FIG. 9

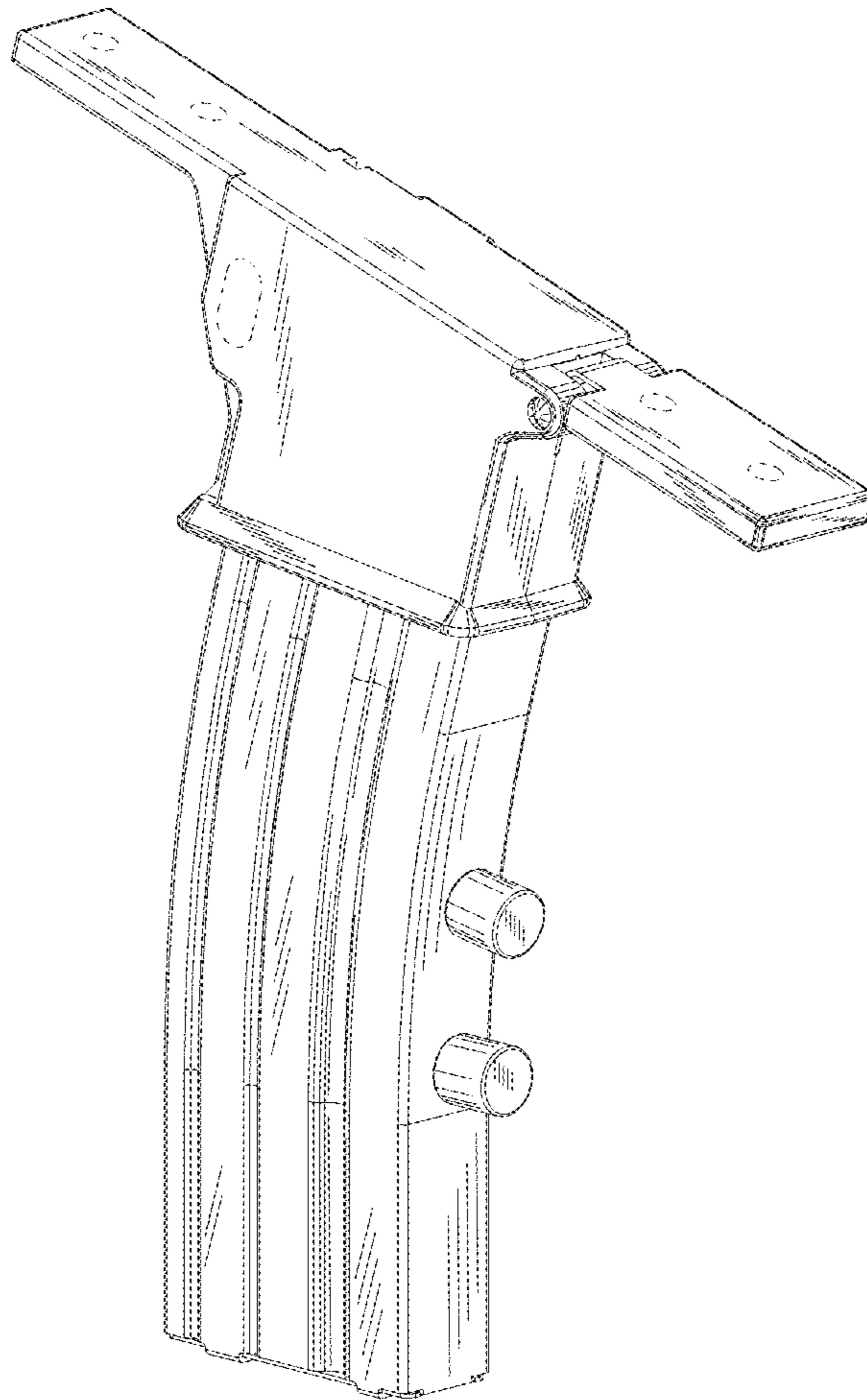

FIG. 10

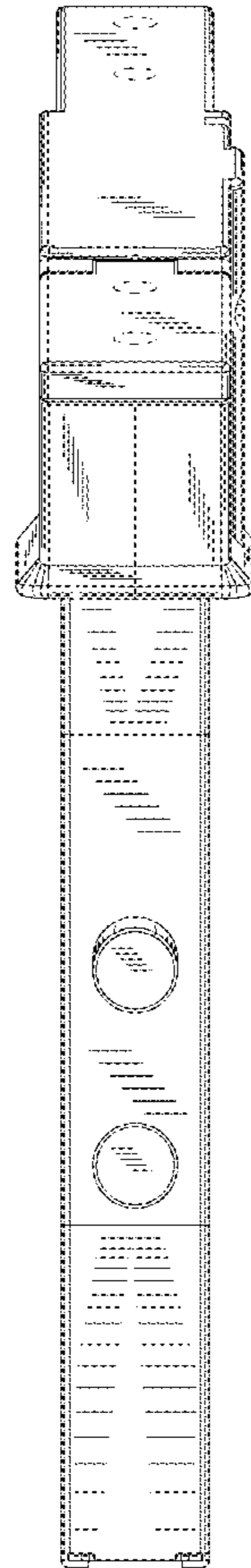

FIG. 11

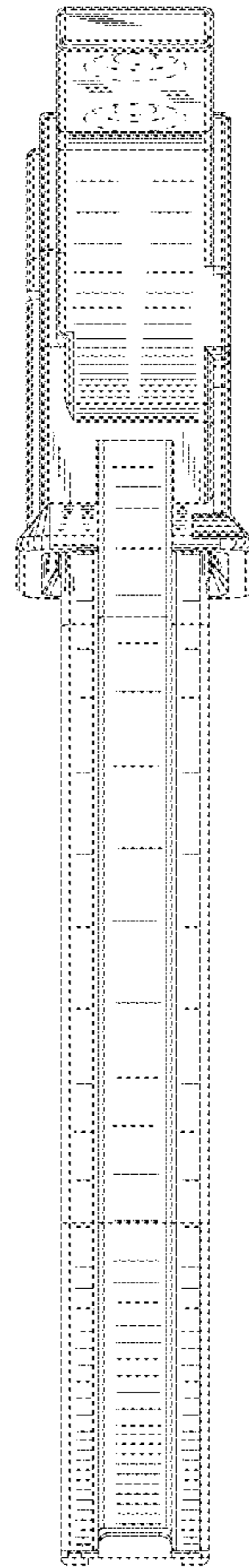

FIG. 12

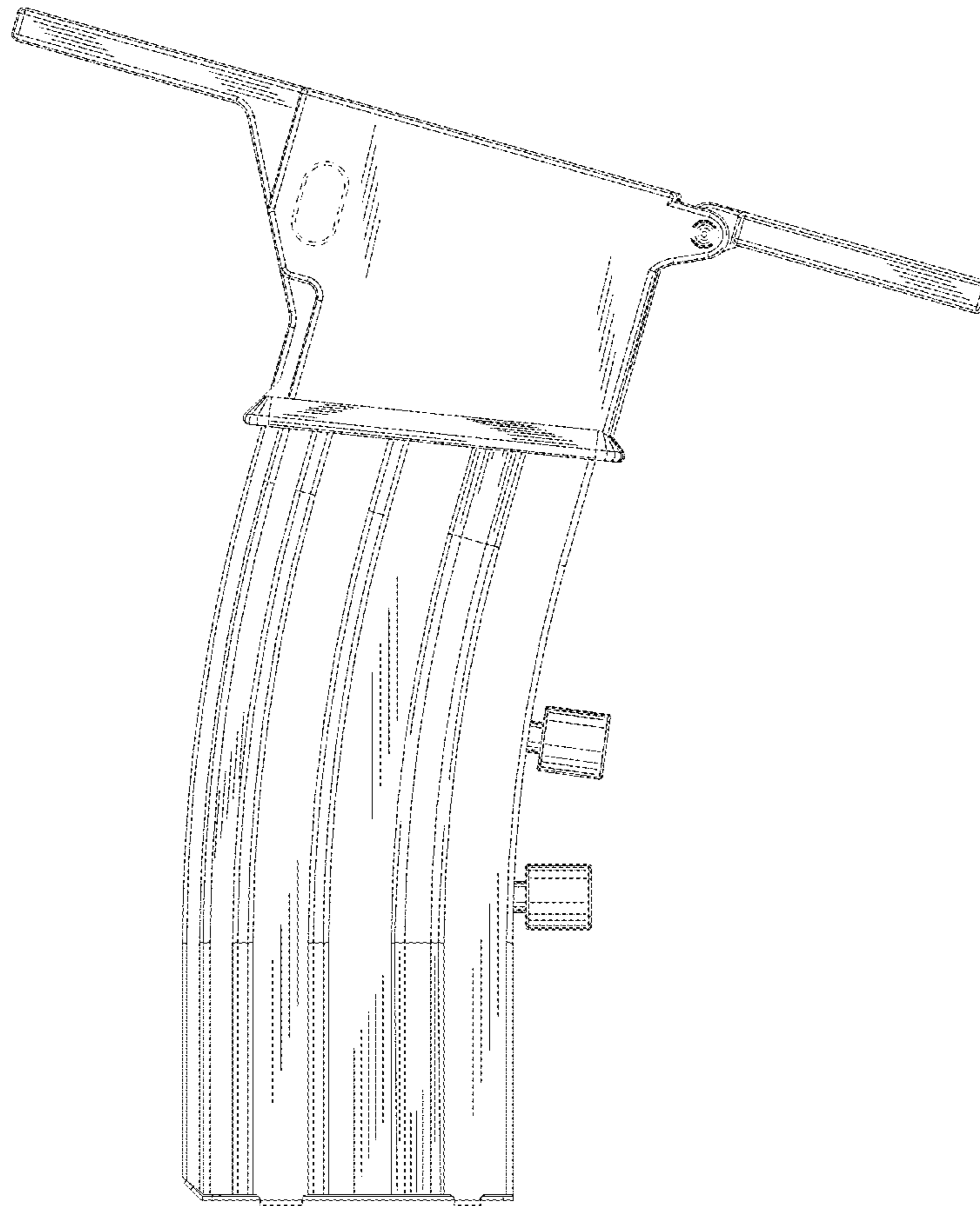

FIG. 13

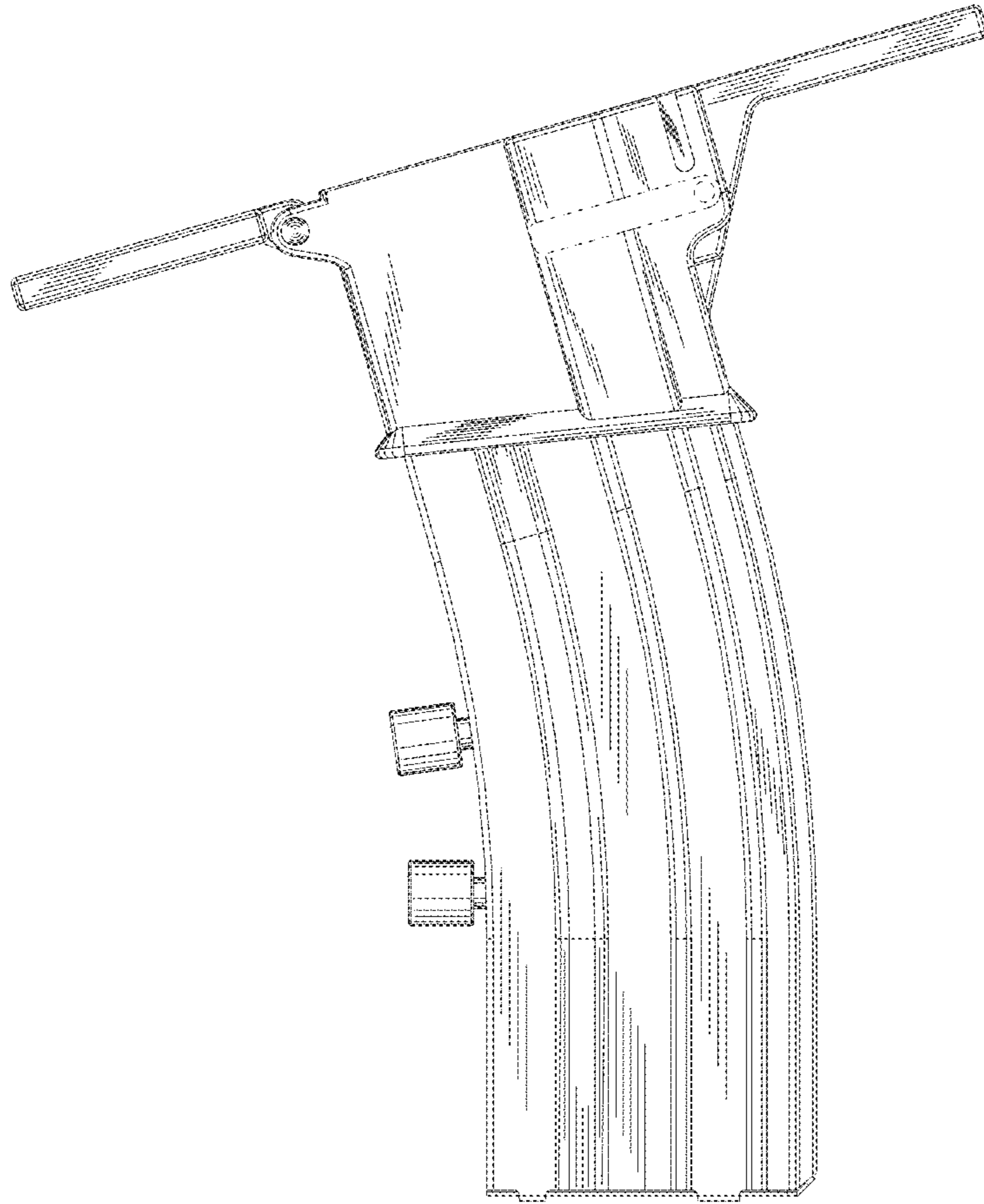

FIG. 14

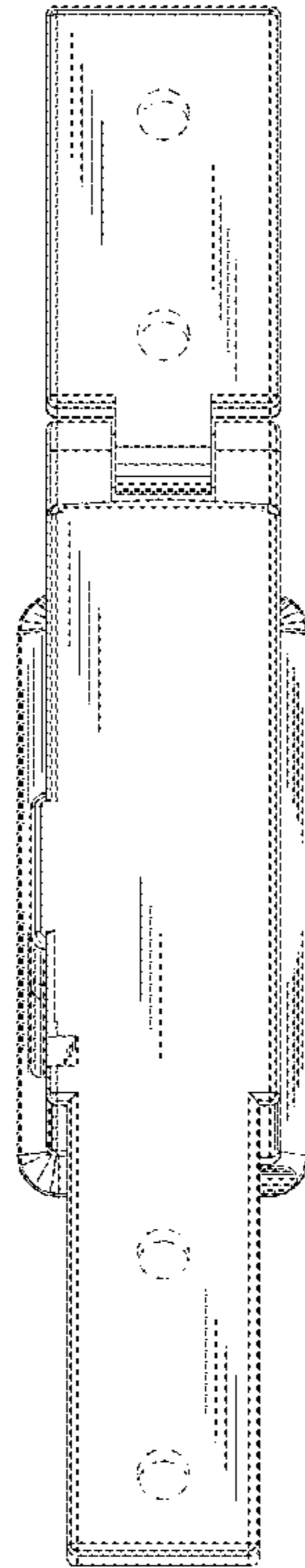

FIG. 15

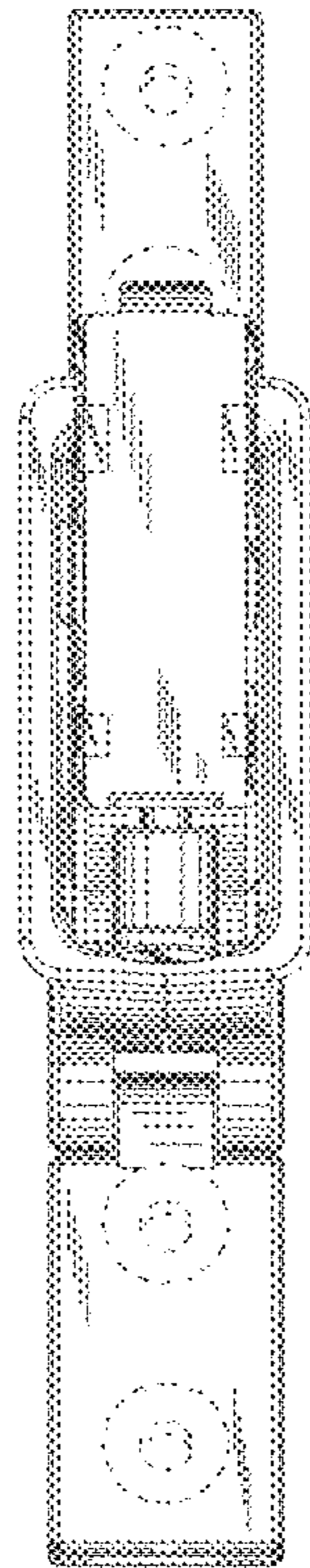

FIG. 16

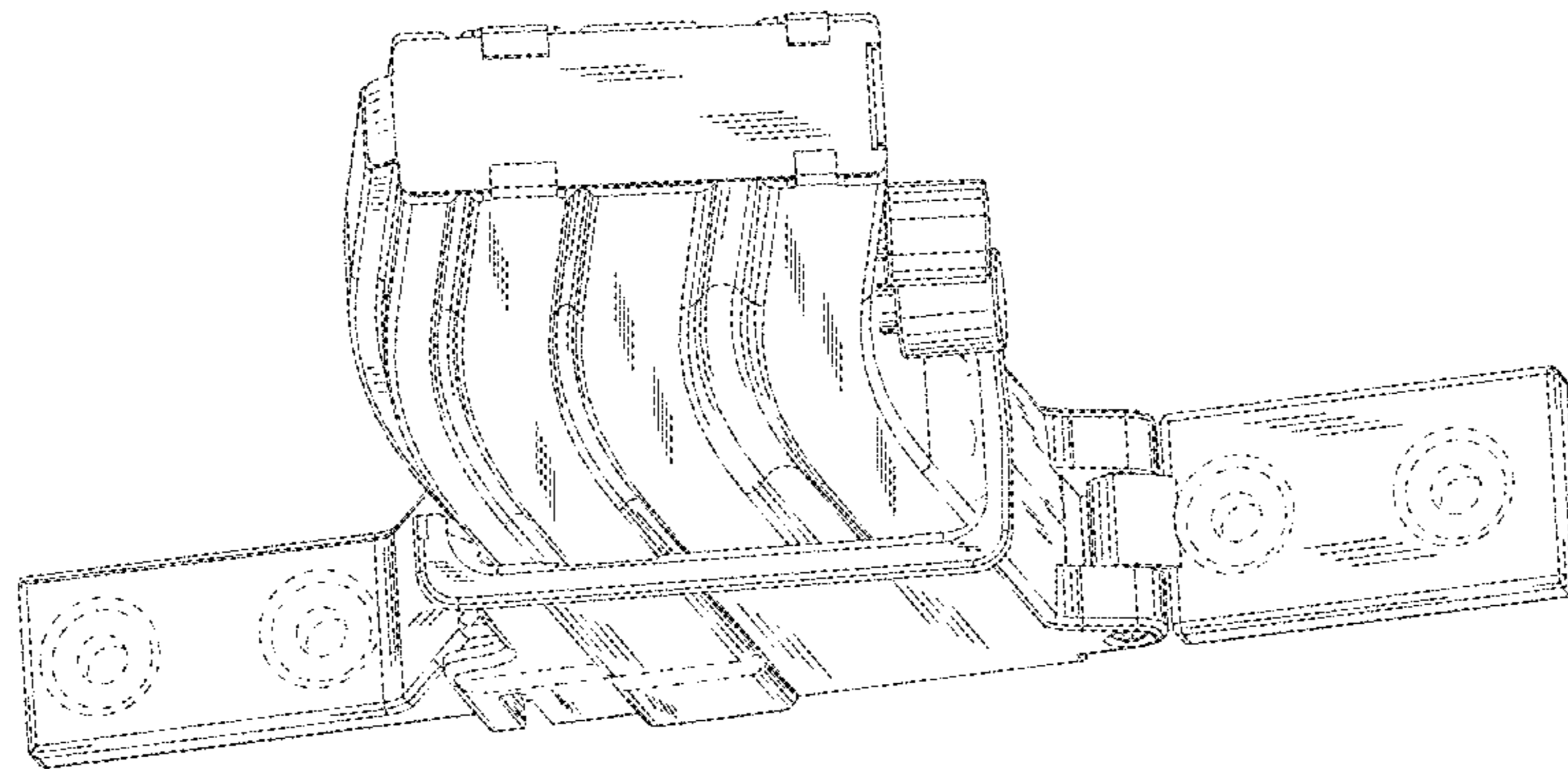

FIG. 17

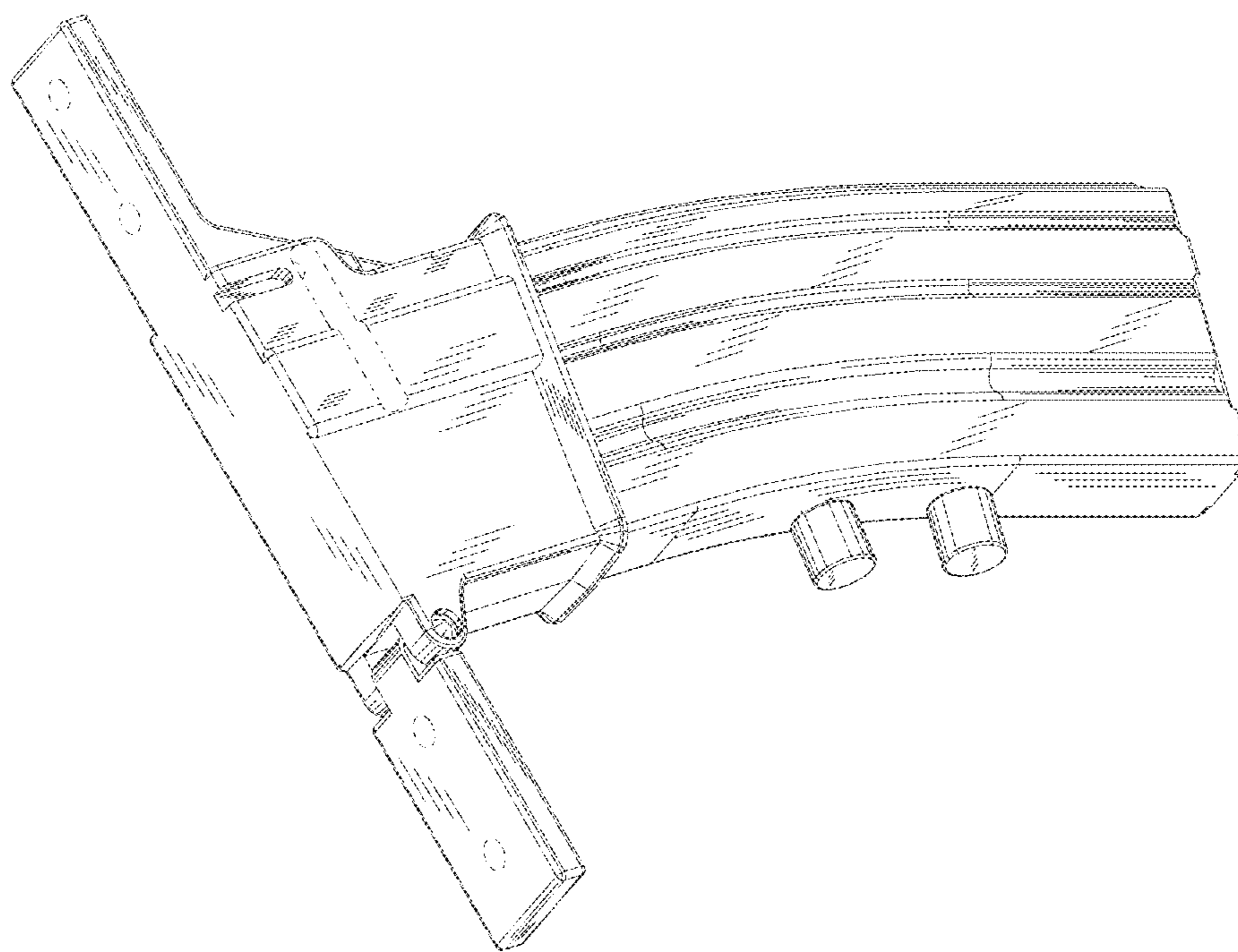

FIG. 18

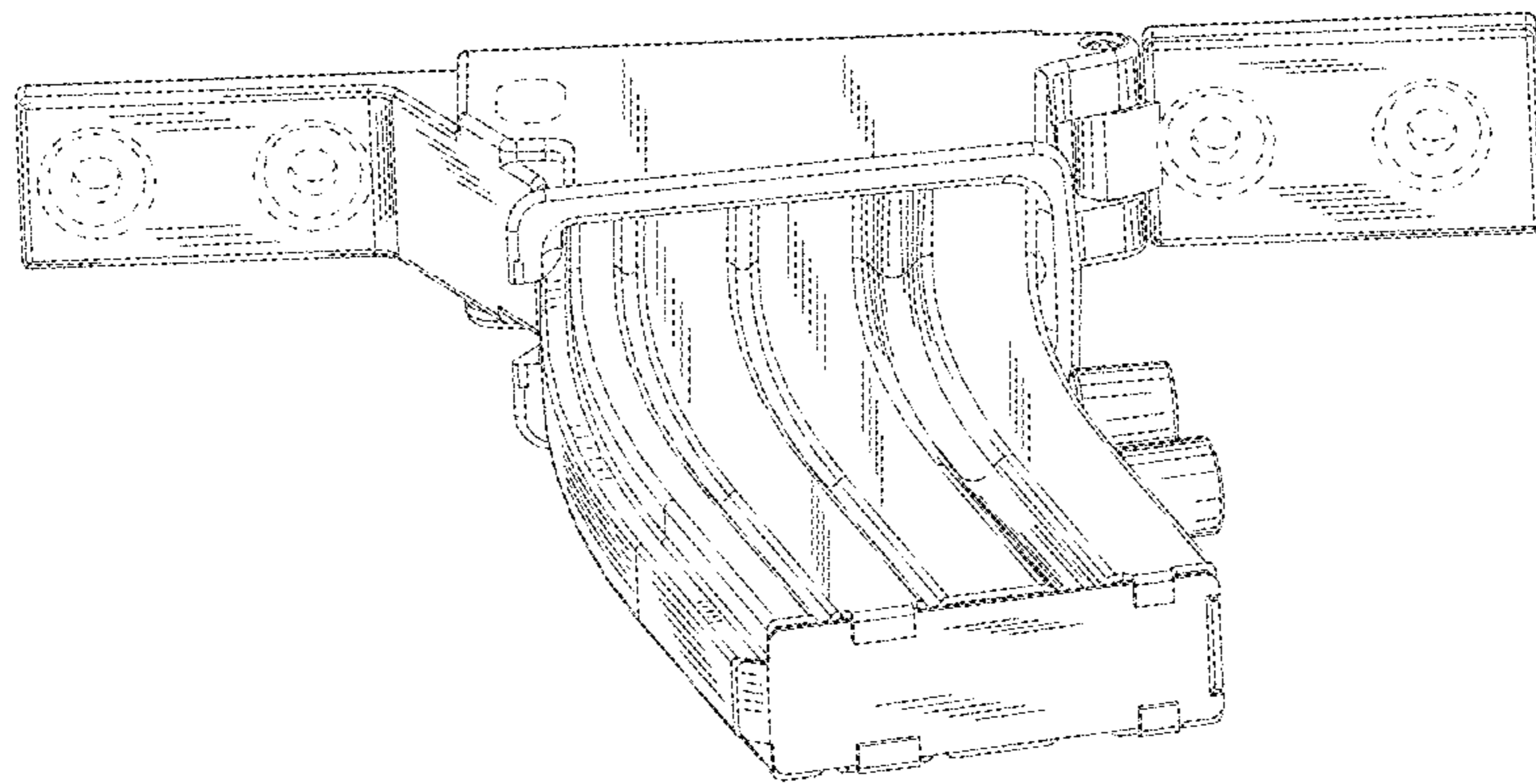

FIG. 19

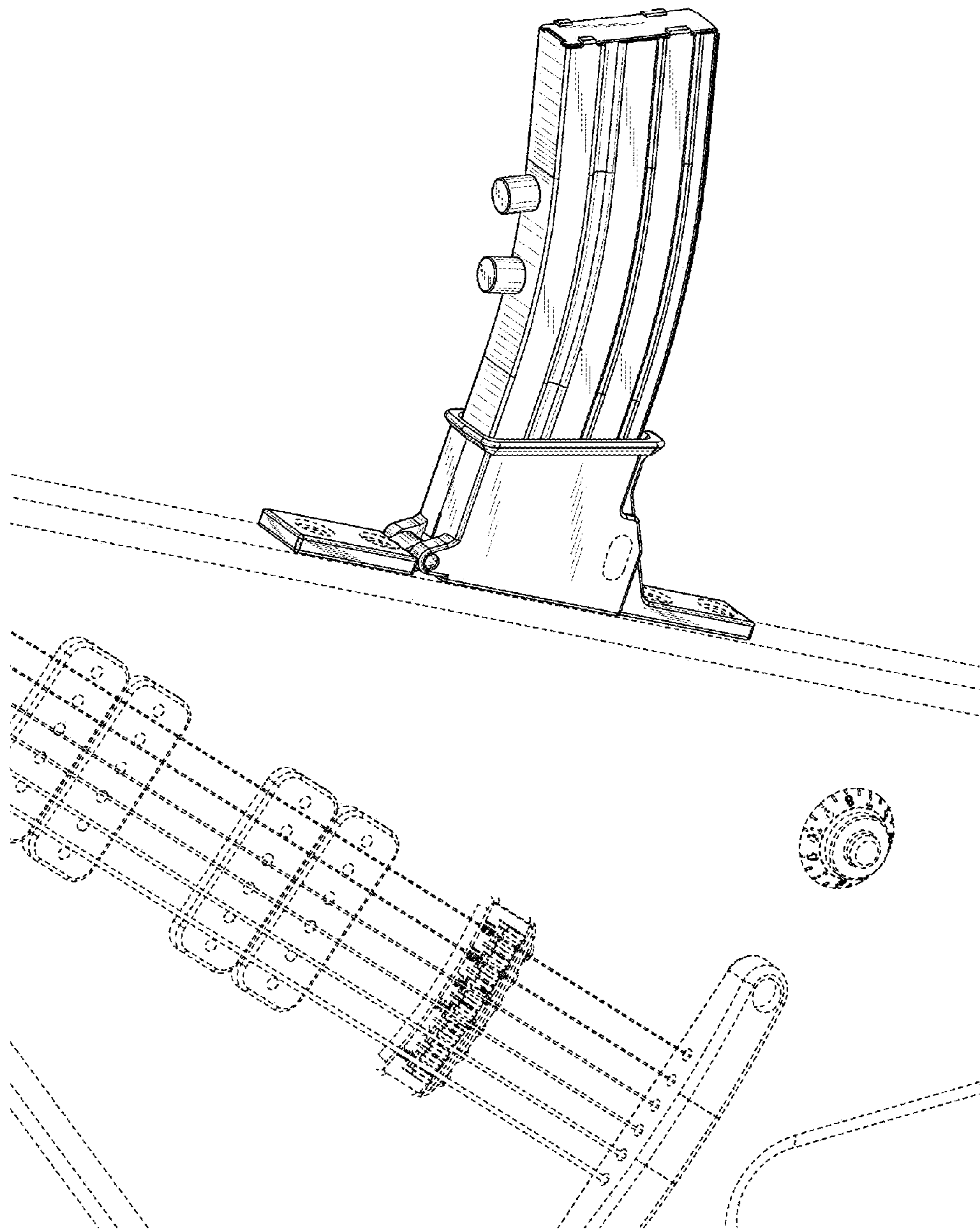

FIG. 20