



US00D739954S

(12) **United States Design Patent**
Ito et al.

(10) **Patent No.:** **US D739,954 S**
(45) **Date of Patent:** **** Sep. 29, 2015**

(54) **SUBSTRATE FOR SPECTROSCOPIC ANALYSIS**

(71) Applicant: **HAMAMATSU PHOTONICS K.K.**,
Hamamatsu-shi, Shizuoka (JP)

(72) Inventors: **Masashi Ito**, Hamamatsu (JP); **Katsumi Shibayama**, Hamamatsu (JP); **Kazuto Ofuji**, Hamamatsu (JP); **Hiroki Oyama**, Hamamatsu (JP); **Yoshihiro Maruyama**, Hamamatsu (JP)

(73) Assignee: **HAMAMATSU PHOTONICS K.K.**,
Hamamatsu-shi, Shizuoka (JP)

(**) Term: **14 Years**

(21) Appl. No.: **29/477,946**

(22) Filed: **Dec. 30, 2013**

(30) **Foreign Application Priority Data**

Jul. 5, 2013 (JP) 2013-015423
Jul. 5, 2013 (JP) 2013-015425
Jul. 5, 2013 (JP) 2013-015426

(51) **LOC (10) Cl.** **24-02**

(52) **U.S. Cl.**
USPC **D24/225**

(58) **Field of Classification Search**
USPC D24/216, 222–226, 231, 232, 169;
D10/80, 81; 422/99, 100, 102, 68.1,
422/69, 560–566; 435/288.1, 288.3, 289.1,
435/283.1; 436/165

See application file for complete search history.

(56) **References Cited**

U.S. PATENT DOCUMENTS

4,761,381 A * 8/1988 Blatt et al. 436/165
D302,294 S * 7/1989 Hillman D24/223
D320,269 S * 9/1991 Hammond D24/225
D324,426 S * 3/1992 Fan et al. D24/226
D328,135 S * 7/1992 Fan et al. D24/216
D351,913 S * 10/1994 Hieb et al. D24/223

D366,938 S * 2/1996 Shartle et al. D24/224
D383,852 S * 9/1997 Shartle et al. D24/224
D395,708 S * 6/1998 Shartle et al. D24/224
D461,906 S * 8/2002 Pham D24/225
D467,348 S * 12/2002 McMichael et al. D24/229
D500,142 S * 12/2004 Crisanti et al. D24/224
D512,512 S * 12/2005 Bell et al. D24/225
D528,215 S * 9/2006 Malmsater D24/232
D530,826 S * 10/2006 Rich et al. D24/225
D531,321 S * 10/2006 Godfrey et al. D24/225
D540,953 S * 4/2007 Ramel et al. D24/224
D559,995 S * 1/2008 Handique et al. D24/232
D621,060 S * 8/2010 Handique D24/225
D636,893 S * 4/2011 Nicholls et al. D24/225
D639,976 S * 6/2011 Francis et al. D24/225
D639,977 S * 6/2011 Francis et al. D24/225
D640,389 S * 6/2011 Francis et al. D24/225
D669,191 S * 10/2012 Handique D24/225
8,330,951 B2 12/2012 Li et al.
D676,145 S * 2/2013 Kouge et al. D24/225
D679,024 S * 3/2013 Kouge et al. D24/225
D692,578 S * 10/2013 Kikuhara et al. D24/216
D700,711 S * 3/2014 Kikuhara et al. D24/216
D702,364 S * 4/2014 Iqbal et al. D24/225
8,709,787 B2 * 4/2014 Handique 435/283.1
2011/0268630 A1 * 11/2011 Williams et al. 422/560

FOREIGN PATENT DOCUMENTS

WO WO-2013/062540 A1 5/2013

OTHER PUBLICATIONS

U.S. Appl. No. 29/477,936, Hamamatsu Photonics K.K.
U.S. Appl. No. 29/477,940, Hamamatsu Photonics K.K.
U.S. Appl. No. 29/477,937, Hamamatsu Photonics K.K.
U.S. Appl. No. 29/477,957, Hamamatsu Photonics K.K.
U.S. Appl. No. 29/477,934, Hamamatsu Photonics K.K.
Leaflet “rSERS™ Raman Enhancing Media,” Raman Systems, a wholly owned subsidiary of Agiltron, Inc., www.ramansystems.com.

* cited by examiner

Primary Examiner — T. Chase Nelson

Assistant Examiner — Mark Cavanna

(74) *Attorney, Agent, or Firm* — Drinker Biddle & Reath LLP

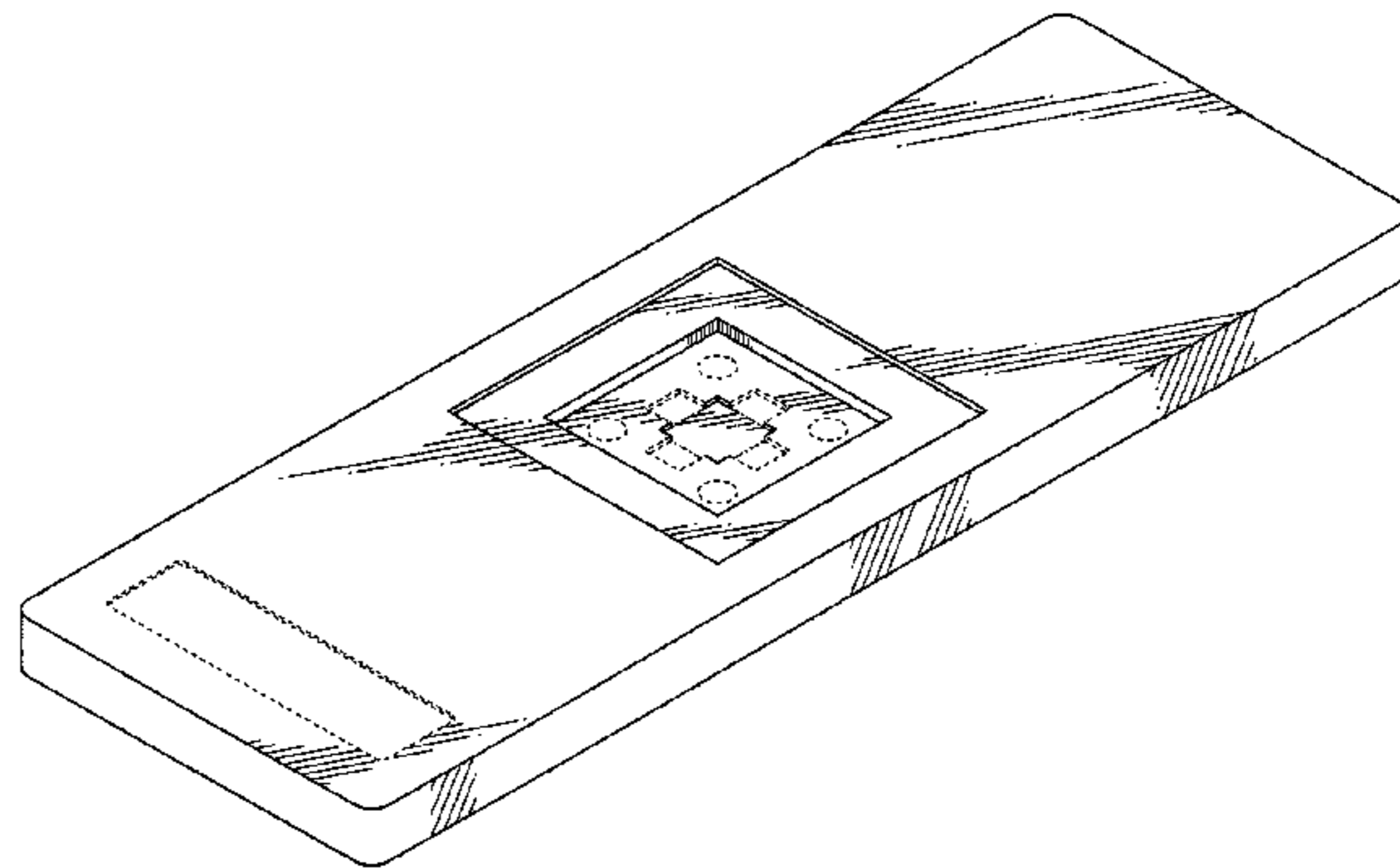
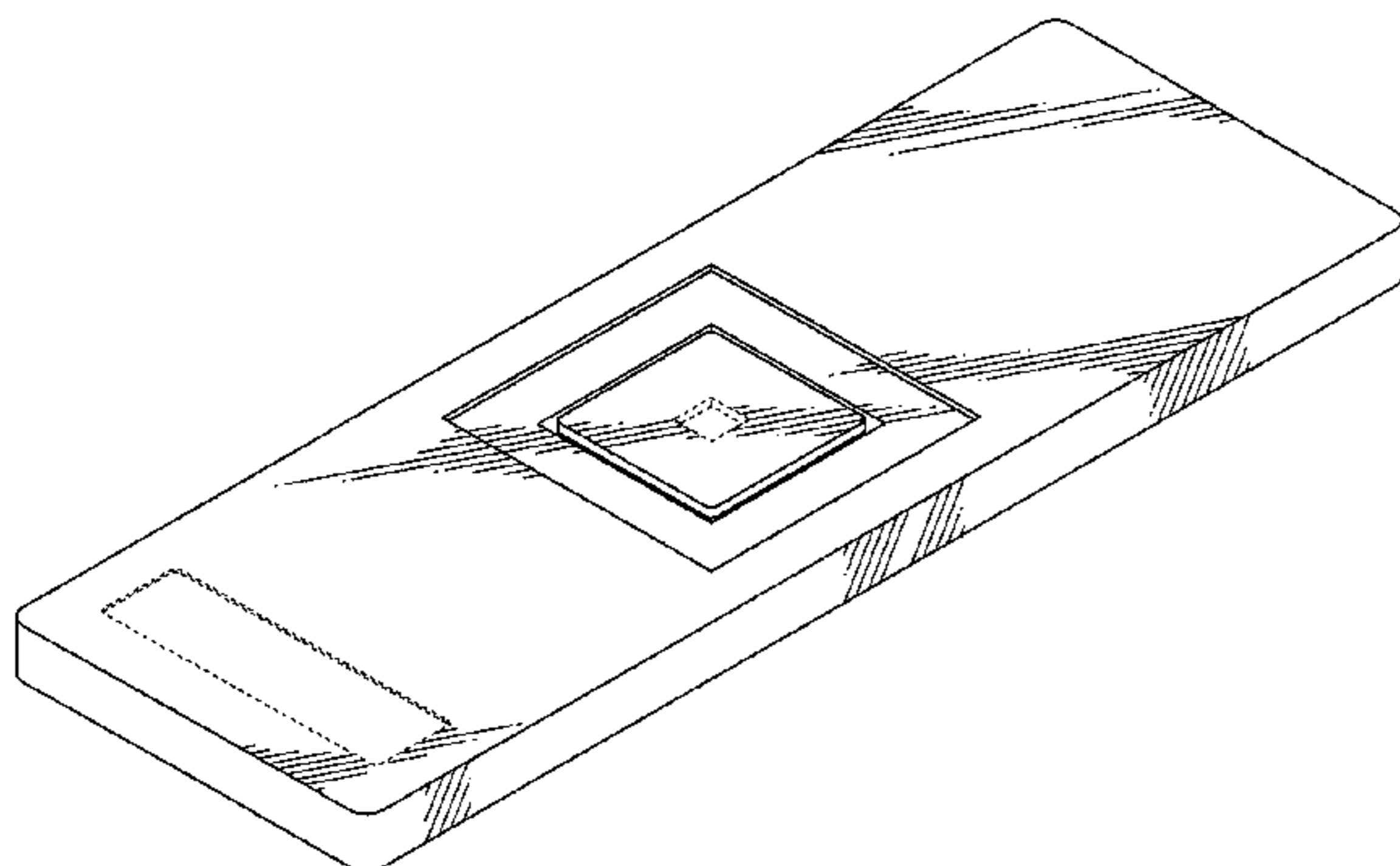

(57)

CLAIM

The ornamental design for a substrate for spectroscopic analysis, as shown and described.

DESCRIPTION

FIG. 1 is a front view of a substrate for spectroscopic analysis according to our new design.

FIG. 2 is a rear view of the substrate for spectroscopic analysis of FIG. 1.

FIG. 3 is a top plan view of the substrate for spectroscopic analysis of FIG. 1.

FIG. 4 is a bottom view of the substrate for spectroscopic analysis of FIG. 1.

FIG. 5 is a right side view of the substrate for spectroscopic analysis of FIG. 1.

FIG. 6 is a left side view of the substrate for spectroscopic analysis of FIG. 1.

FIG. 7 is a perspective of the substrate for spectroscopic analysis of FIG. 1.

FIG. 8 is a top plan view without the cover part of the substrate for spectroscopic analysis of FIG. 1.

FIG. 9 is a perspective view without the cover part of the substrate for spectroscopic analysis of FIG. 1.

FIG. 10 is a sectional view taken along the line 10-10 of the substrate for spectroscopic analysis of FIG. 3.

FIG. 11 is a sectional view taken along the line 11-11 of the substrate for spectroscopic analysis of FIG. 1.

FIG. 12 is a sectional view taken along the line 12-12 of the substrate for spectroscopic analysis of FIG. 8.

FIG. 13 is an enlarged sectional view taken along the line 13-13 of the substrate for spectroscopic analysis of FIG. 10; and,

FIG. 14 is a reference sectional view taken along the line 10-10 of the substrate for spectroscopic analysis of FIG. 3 in use, wherein the element is inserted in the concave part for element and the glass plate is set above the cover part.

The features shown in dotted lines depict environmental subject matter only and form no part of the claimed design.

The broken lines having alternating long and short segments define bounds of the claimed design and form no part thereof.

The whole of the substrate for spectroscopic analysis of our design is transparent.

The broken lines show portions of the substrate for spectroscopic analysis that form no part of the claimed design.

1 Claim, 14 Drawing Sheets

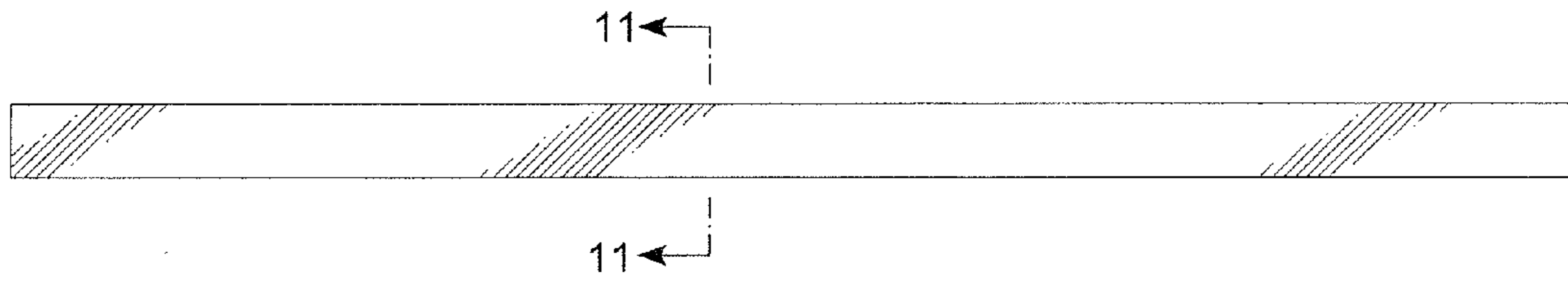

Fig. 1

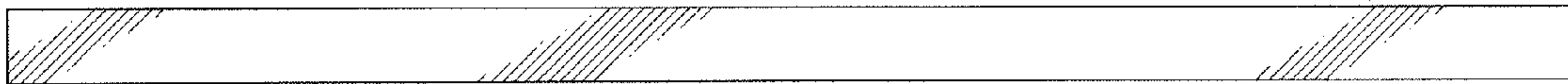

Fig.2

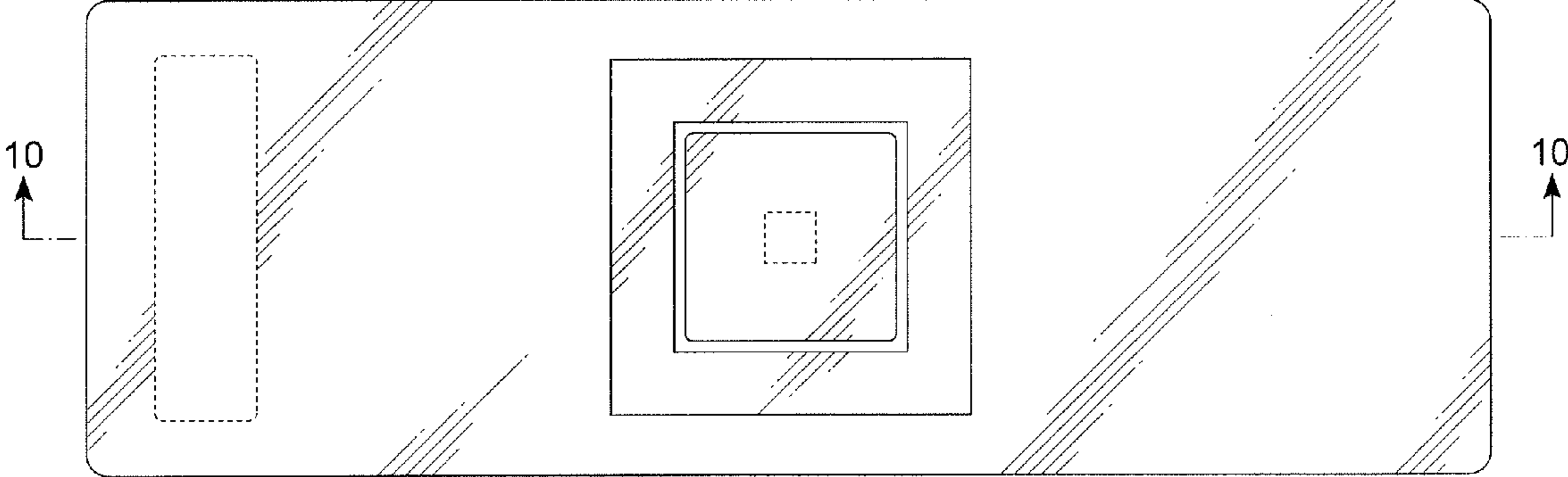

Fig.3

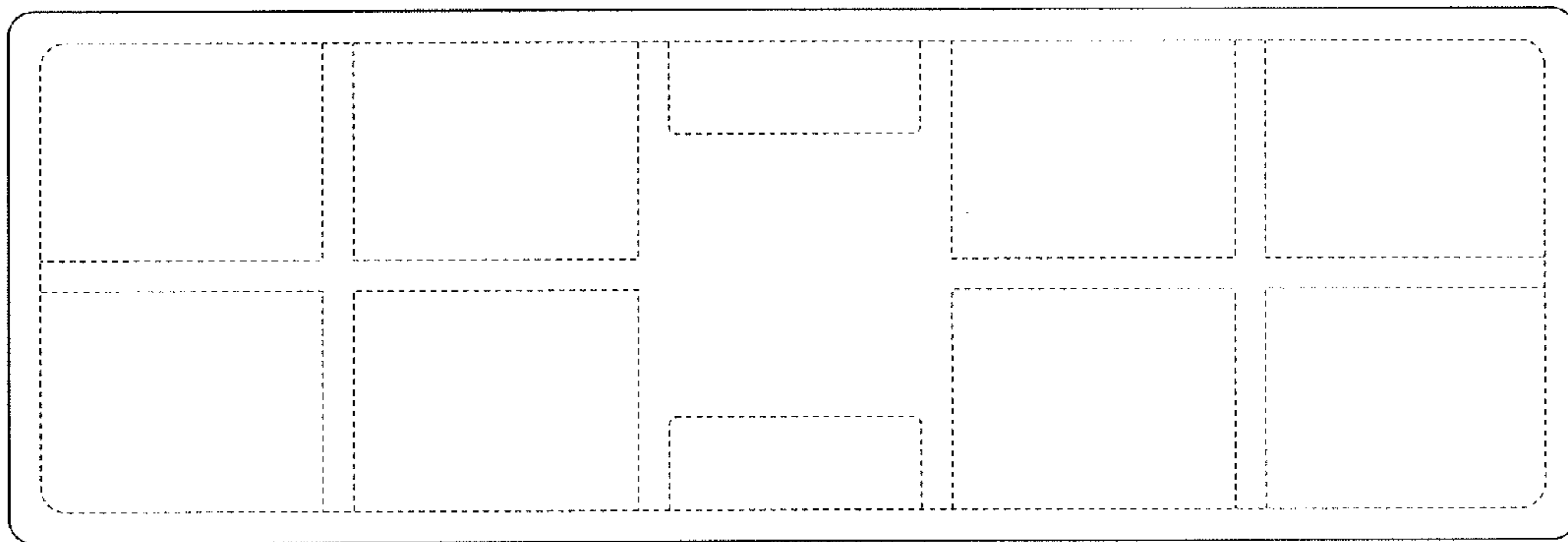

Fig.4



Fig.5

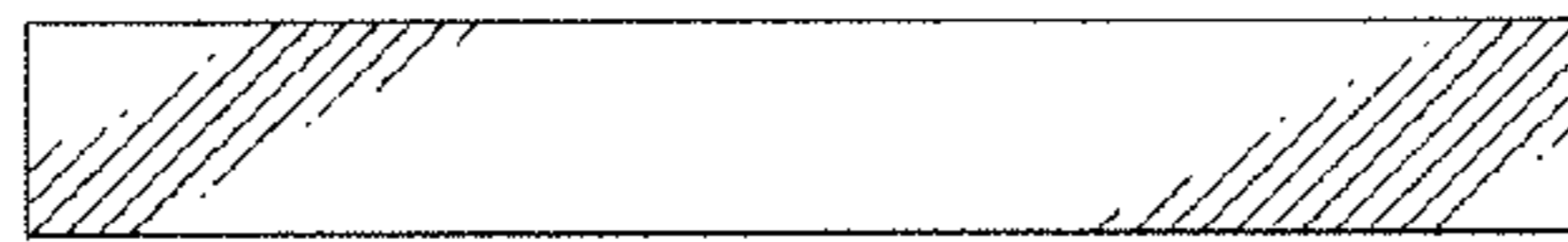

Fig.6

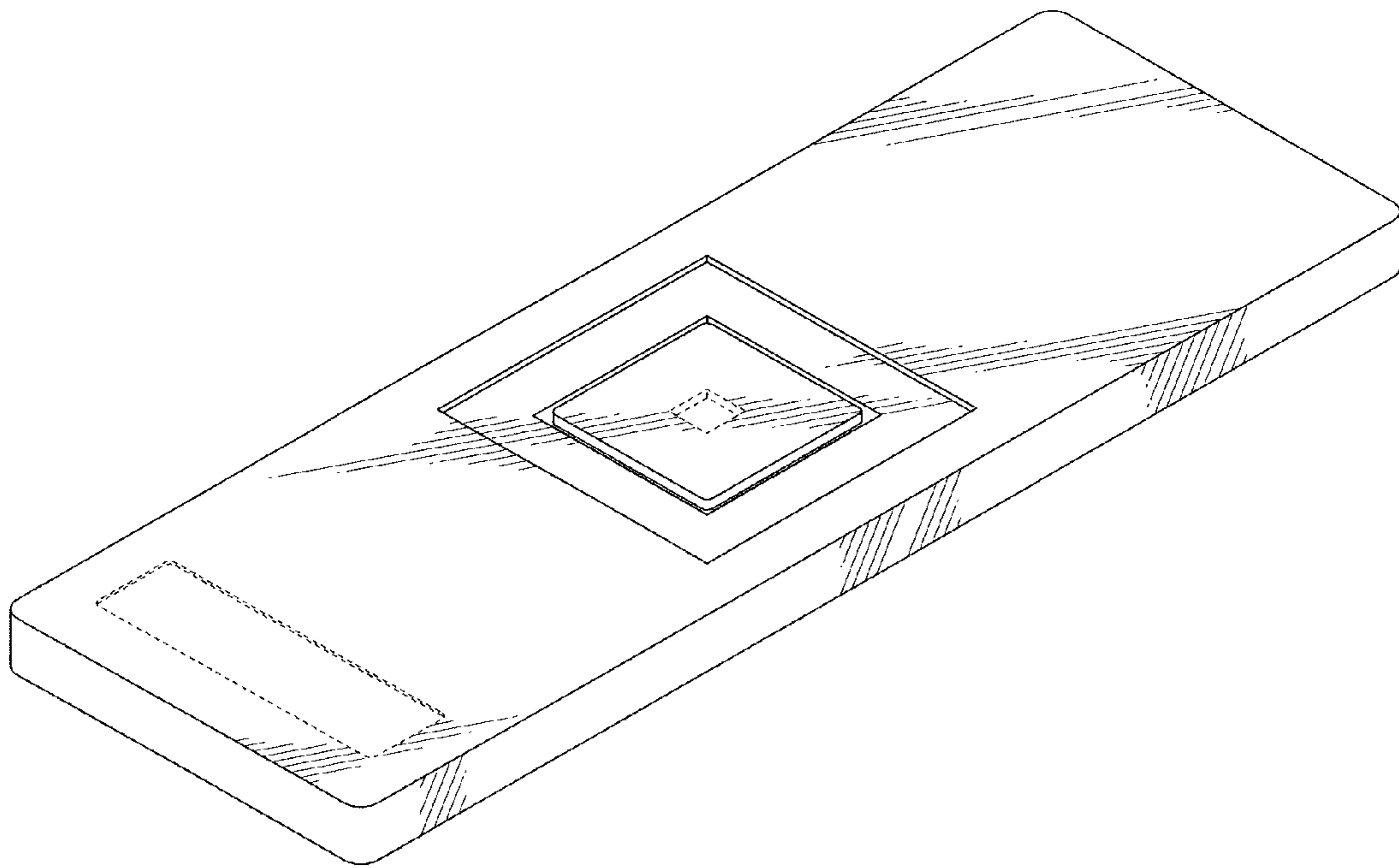

Fig.7

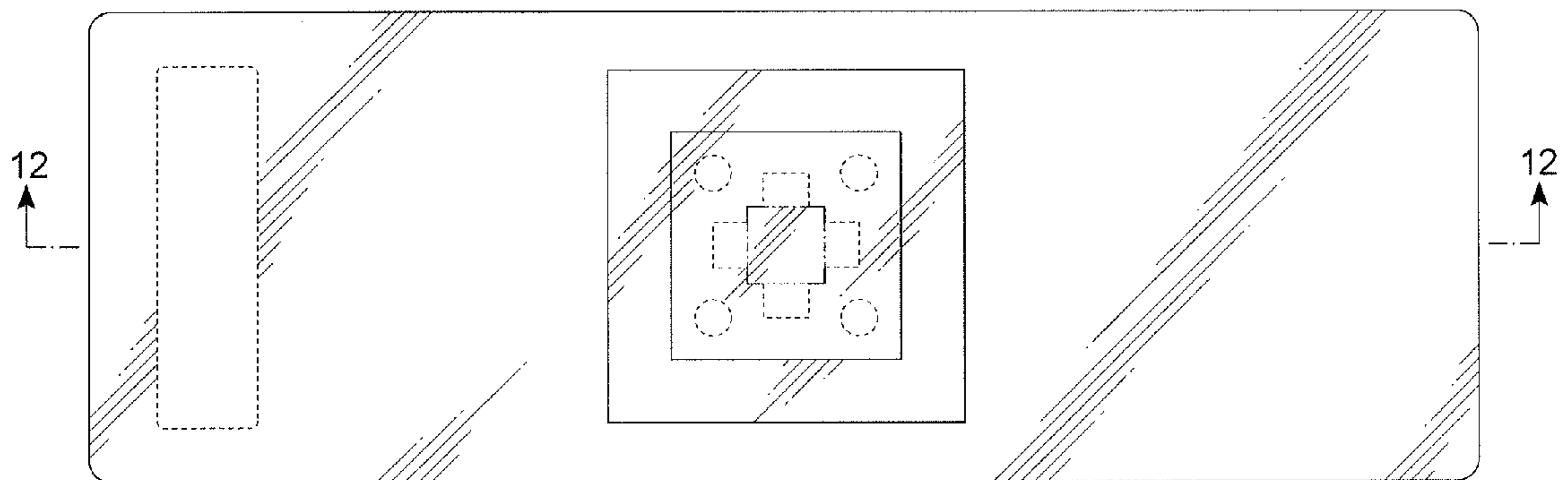

Fig.8

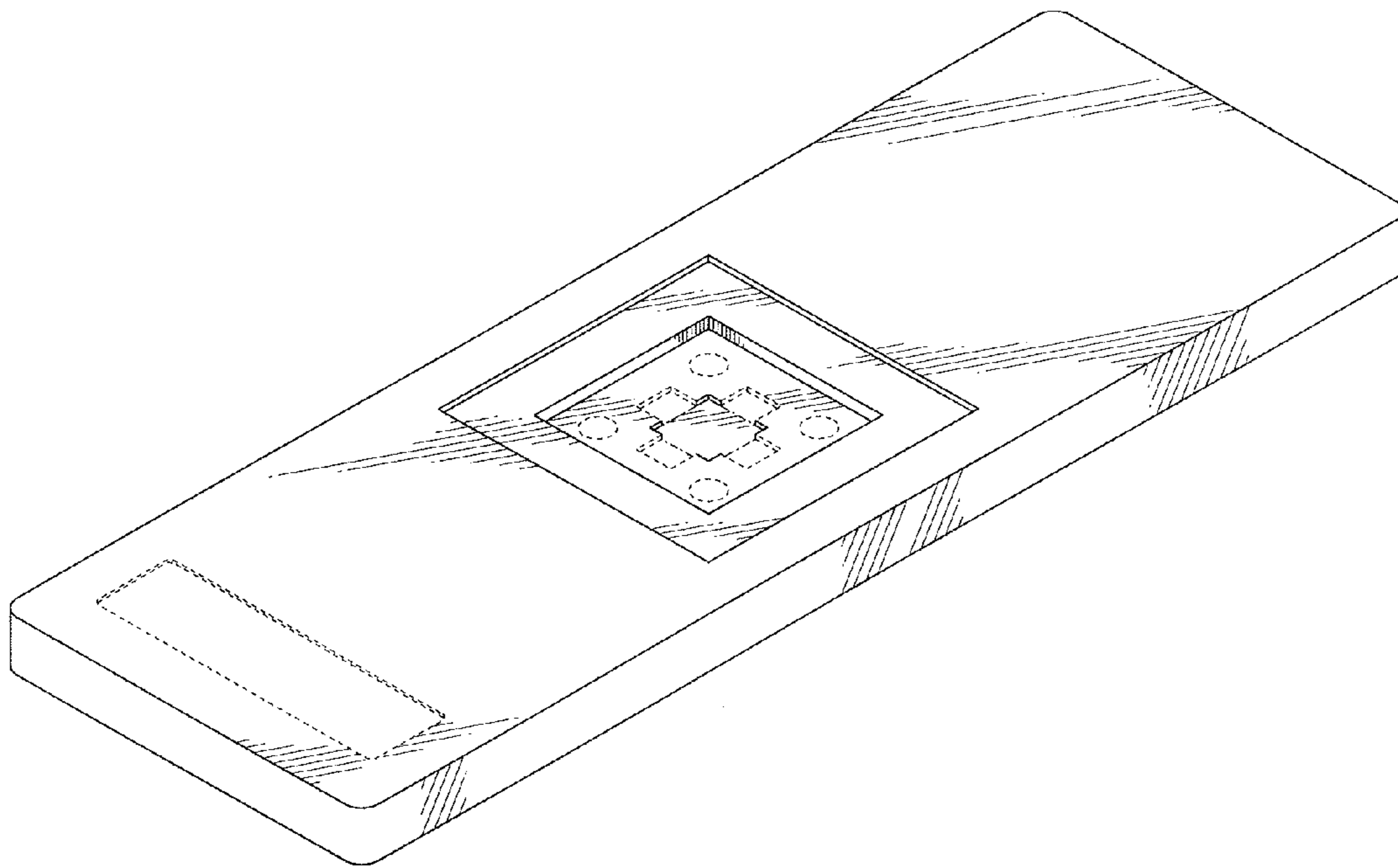

Fig.9

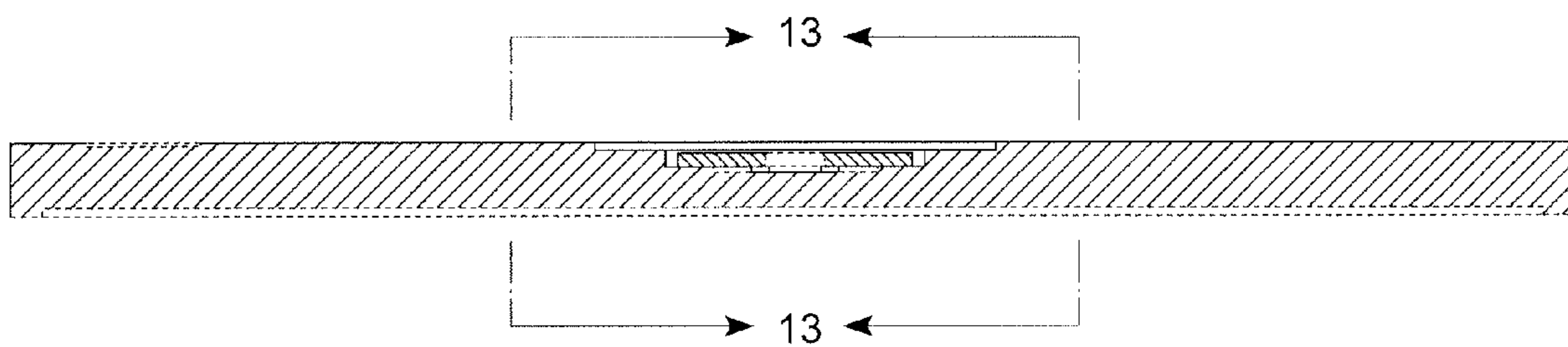

Fig.10

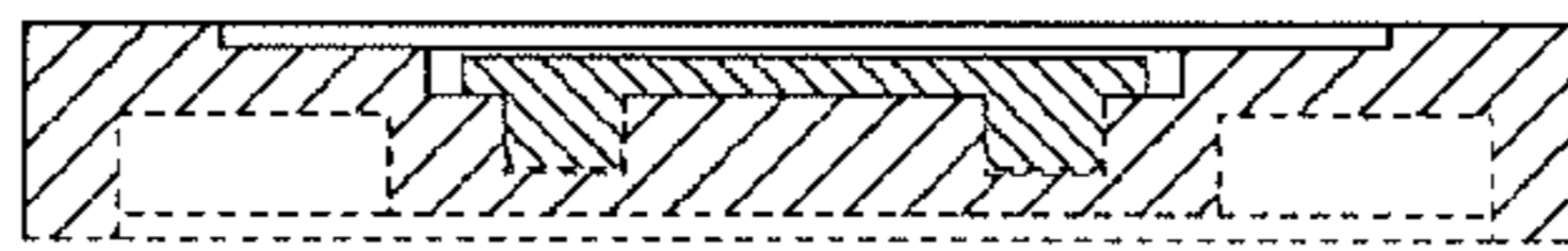

Fig.11

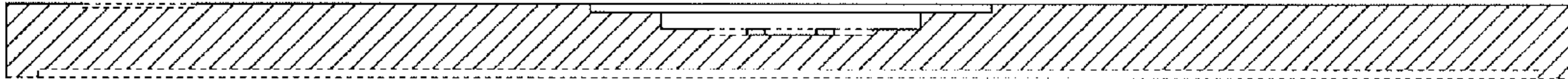

Fig.12

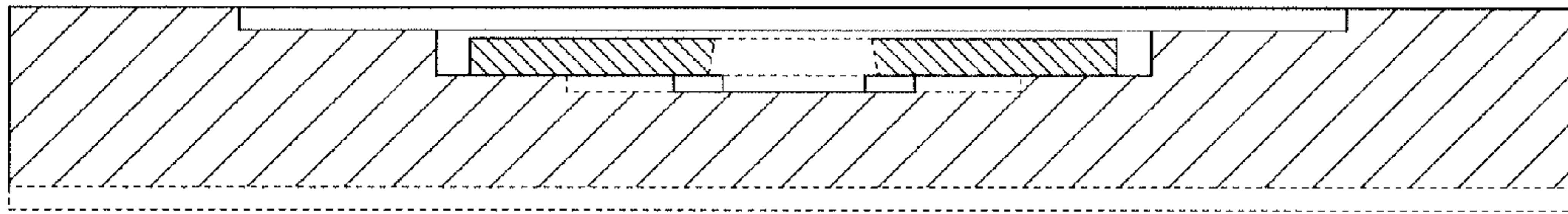

Fig.13

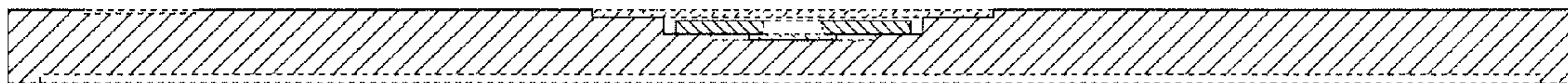

Fig. 14