

US00D739801S

(12) **United States Design Patent**
Bundy

(10) **Patent No.:** **US D739,801 S**

(45) **Date of Patent:** **** Sep. 29, 2015**

(54) **VEHICLE STEP RAIL**

(71) Applicant: **Iron Cross Automotive, Inc.**, Tulsa, OK (US)

(72) Inventor: **Troy Bundy**, Tulsa, OK (US)

(73) Assignee: **IRON CROSS AUTOMOTIVE, INC.**, Tulsa, OK (US)

(**) Term: **14 Years**

(21) Appl. No.: **29/495,087**

(22) Filed: **Jun. 26, 2014**

(51) **LOC (10) Cl.** **12-16**

(52) **U.S. Cl.**
USPC **D12/203**

(58) **Field of Classification Search**
USPC D12/89, 203, 314; 182/64.1, 127; 280/5.3, 163, 164.2, 166, 169, 291; D25/62, 63, 68, 69, 138, 152-158
CPC B60C 11/0008; B60C 11/0041; B60C 11/01; B60C 11/12; E06C 1/005; E06C 1/02; E06C 5/00; E06C 5/02; E06C 5/04
See application file for complete search history.

(56) **References Cited**

U.S. PATENT DOCUMENTS

D330,536	S *	10/1992	Holloway et al.	D12/203
5,501,475	A *	3/1996	Bundy	280/166
D434,711	S *	12/2000	McQuiston	D12/203
D488,759	S *	4/2004	Hattori et al.	D12/203
D535,928	S *	1/2007	Crandall	D12/203
D546,259	S *	7/2007	Metros et al.	D12/203
7,287,770	B2 *	10/2007	Drabant et al.	280/163
7,377,564	B1 *	5/2008	Baffy et al.	293/117
7,677,583	B2 *	3/2010	Armstrong et al.	280/163
D632,627	S *	2/2011	Huang-Tsai	D12/203
7,946,604	B2 *	5/2011	Crandall	280/163
D668,689	S *	10/2012	Bang	D12/203

D676,368	S *	2/2013	Cover	D12/203
8,448,968	B1 *	5/2013	Grote et al.	280/163
8,641,068	B1 *	2/2014	Bundy	280/163
2011/0079981	A1 *	4/2011	McFarlane	280/163
2011/0266766	A1 *	11/2011	Huang-Tsai	280/169
2012/0104718	A1 *	5/2012	Alvarez et al.	280/163

* cited by examiner

Primary Examiner — George D Kirschbaum

Assistant Examiner — Natasha Vujcic

(57) **CLAIM**

The ornamental design for a vehicle step rail, as shown and described.

DESCRIPTION

FIG. 1 is a front elevation view of the left side of a vehicle step rail, showing our new design;
 FIG. 2 is a front elevation view of the right side of the vehicle step rail;
 FIG. 3 is a top plan view thereof relative to FIG. 1;
 FIG. 4 is a top plan view thereof relative to FIG. 2;
 FIG. 5 is a bottom plan view thereof relative to FIG. 1;
 FIG. 6 is a bottom plan view thereof relative to FIG. 2;
 FIG. 7 is a left side elevation view thereof, at an enlarged scale, the right side elevation view being the mirror opposite thereto;
 FIG. 8 is a rear elevation view thereof, at a greatly reduced scale;
 FIG. 9 is a perspective view thereof, showing the front, top, and left side;
 FIG. 10 is a perspective view thereof, showing the front, top, and right side; and,
 FIG. 11 is an end view of the rail portion of the vehicle step rail of FIG. 1.
 The broken lines shown in the drawing figures represent portions of the vehicle step rail that form no part of the claimed design.

1 Claim, 5 Drawing Sheets

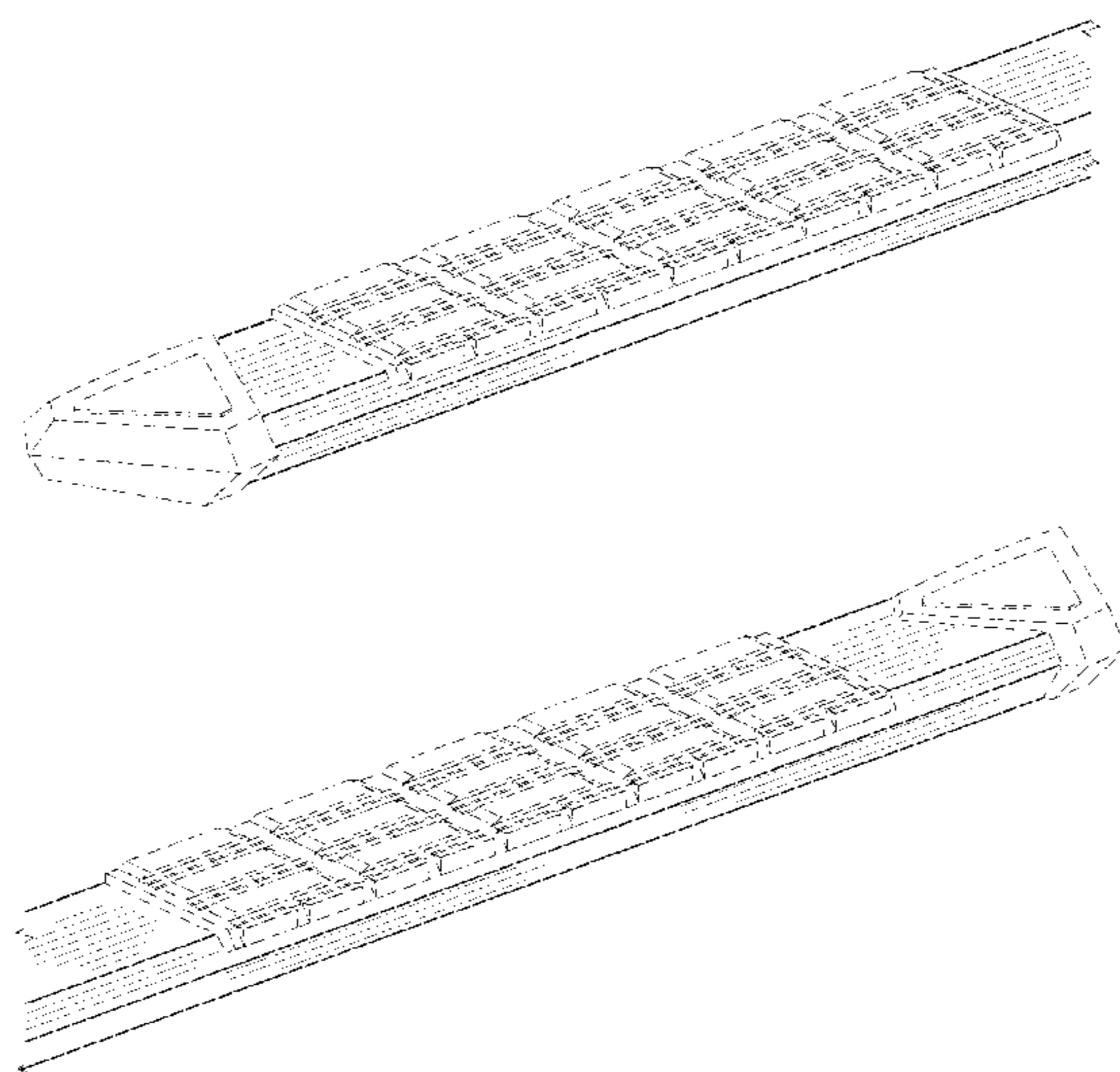

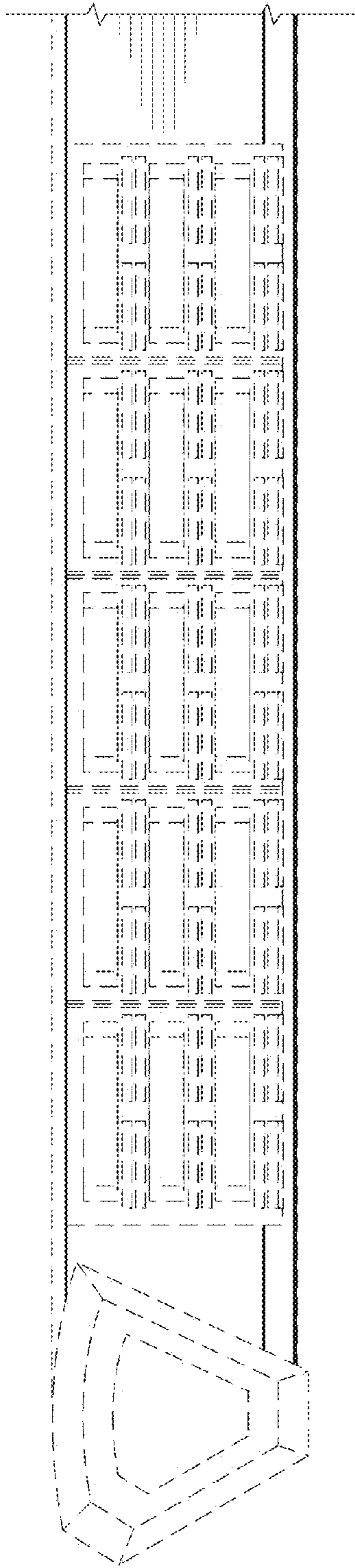

Fig. 3

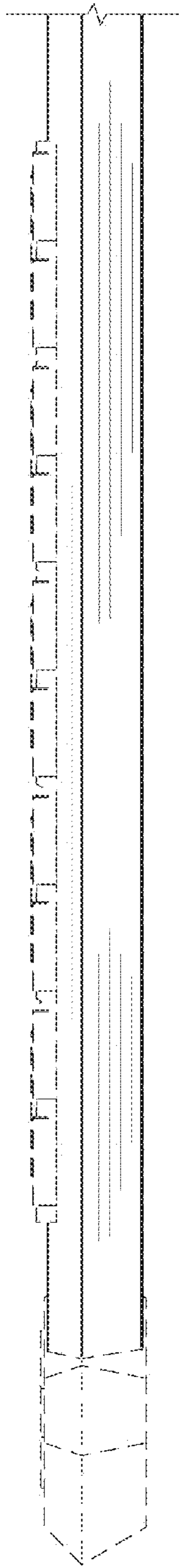

Fig. 1

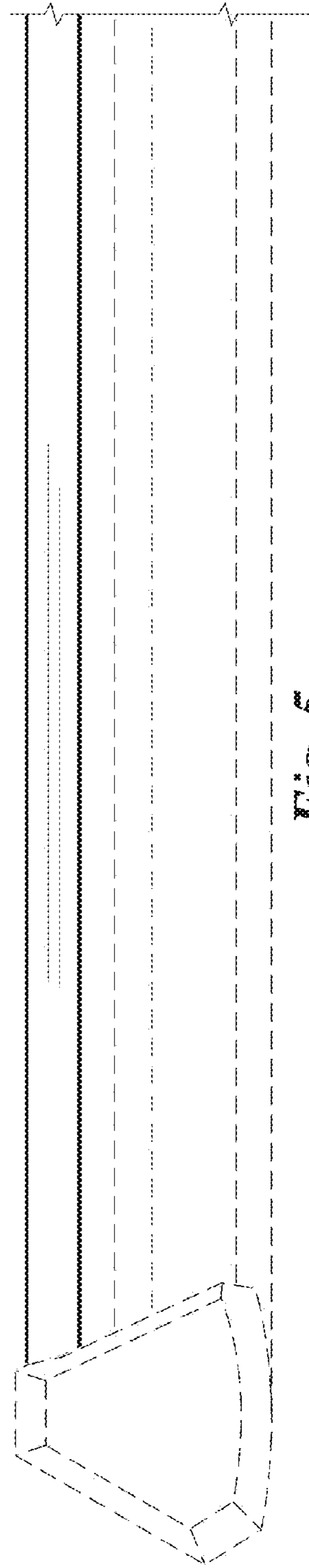

Fig. 5

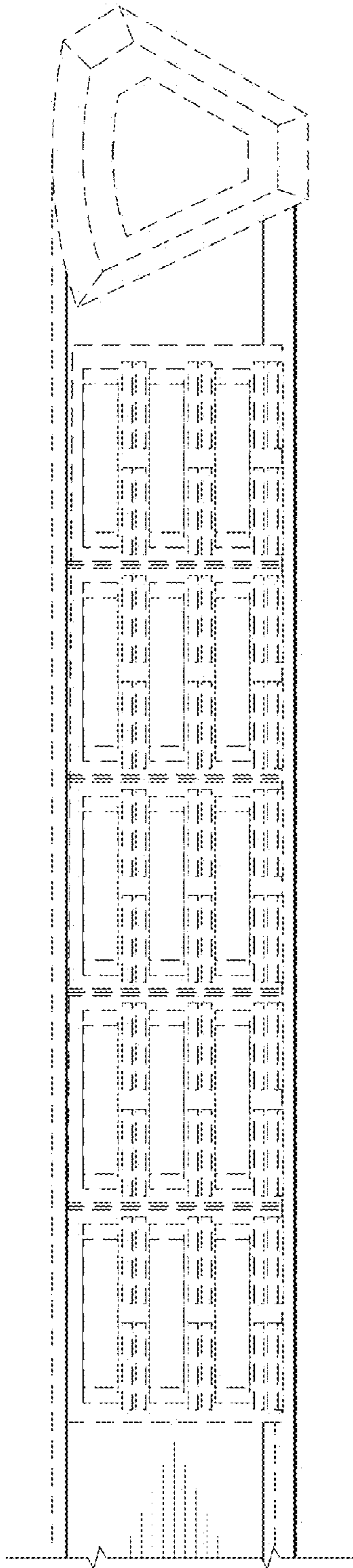

Fig. 4

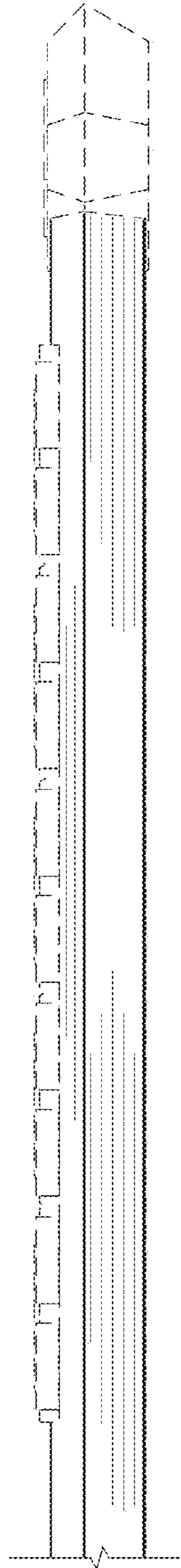

Fig. 2

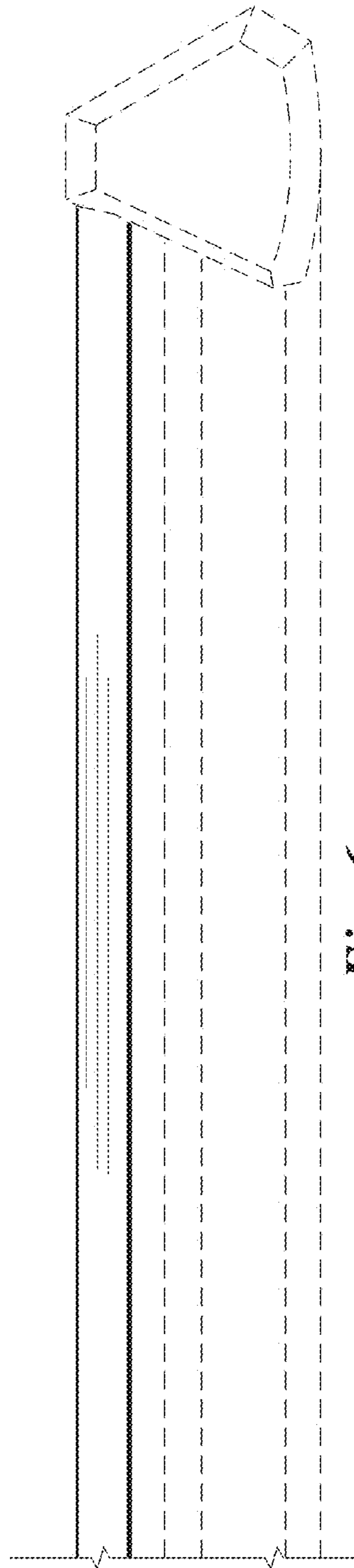

Fig. 6

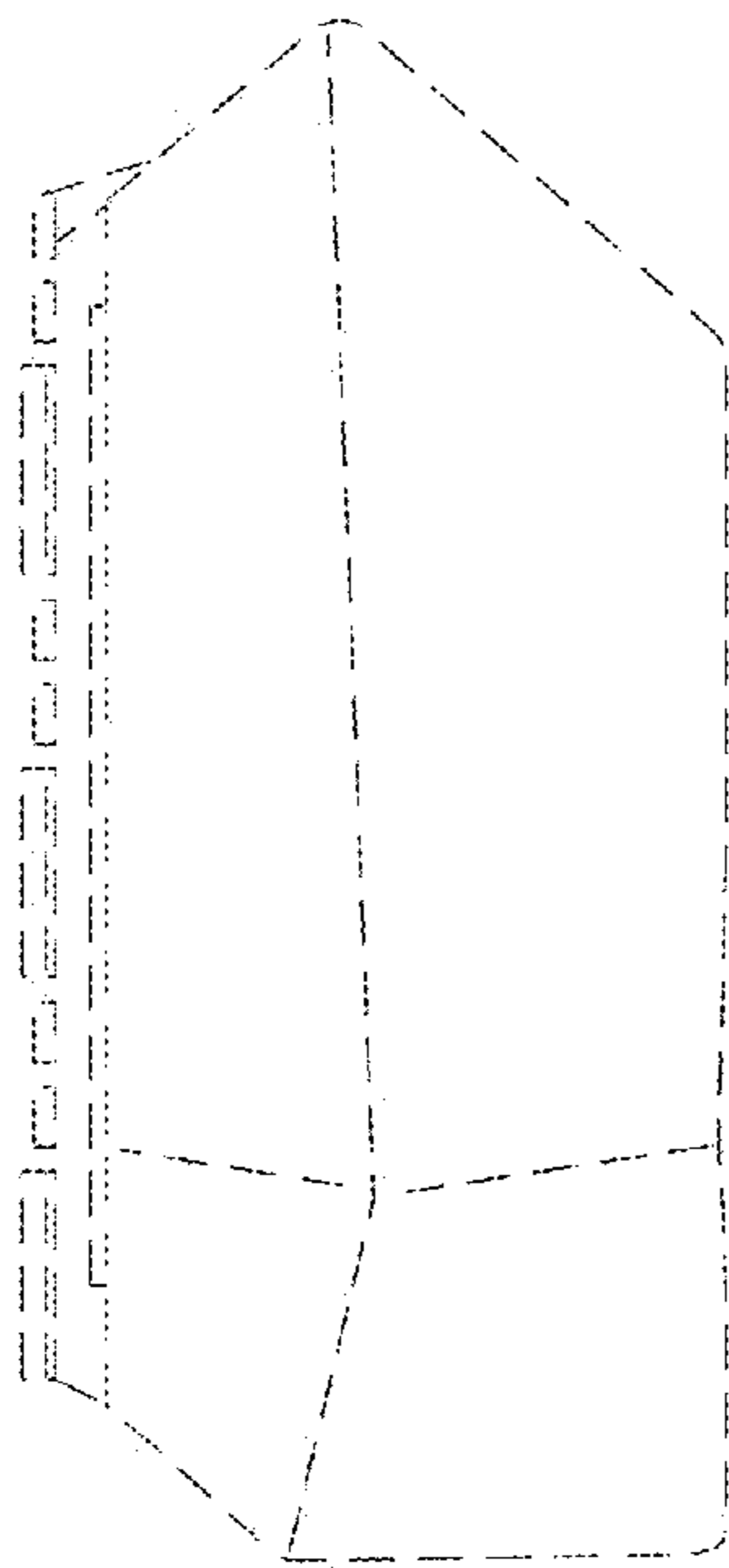

Fig. 7

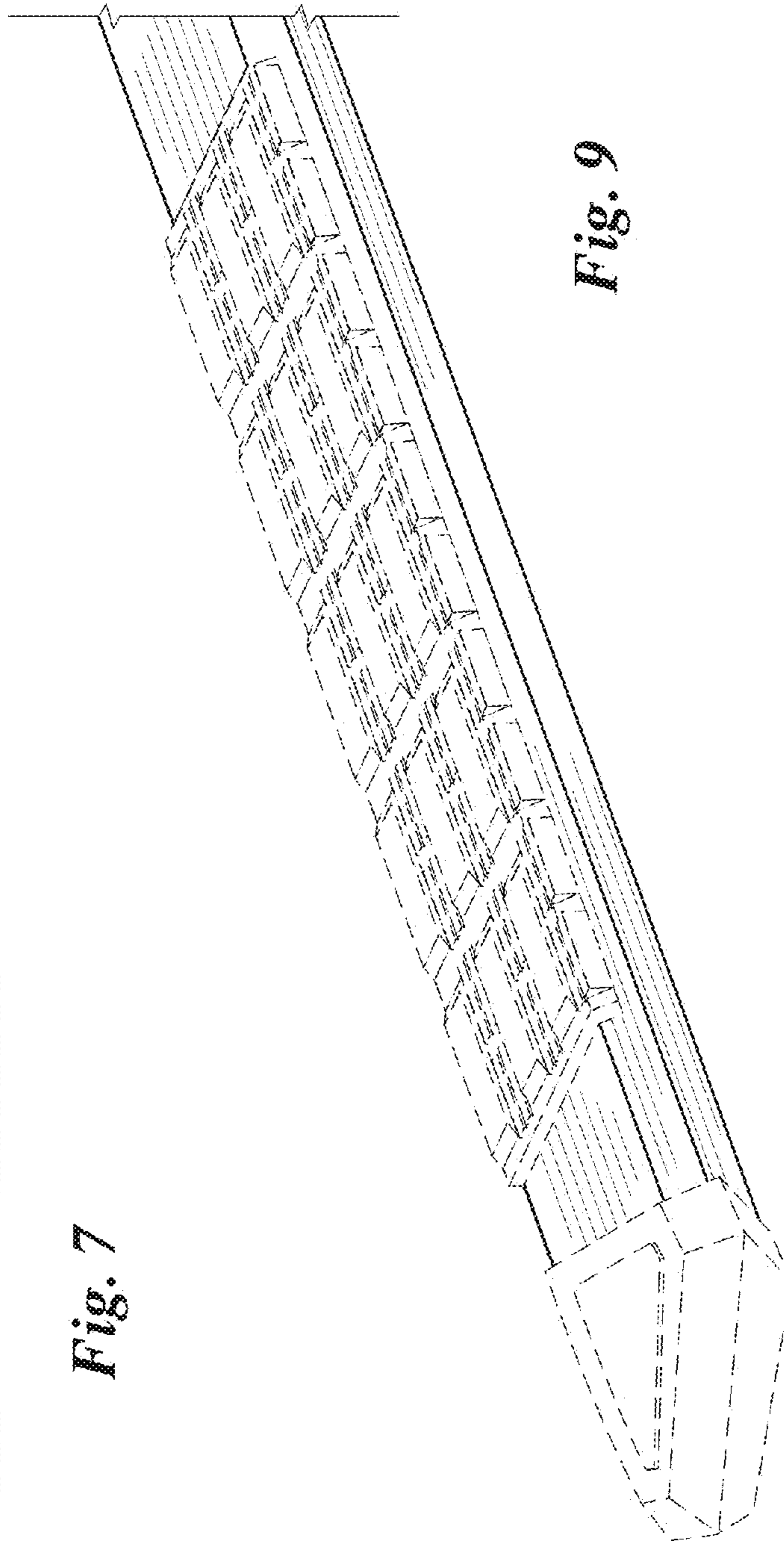

Fig. 9

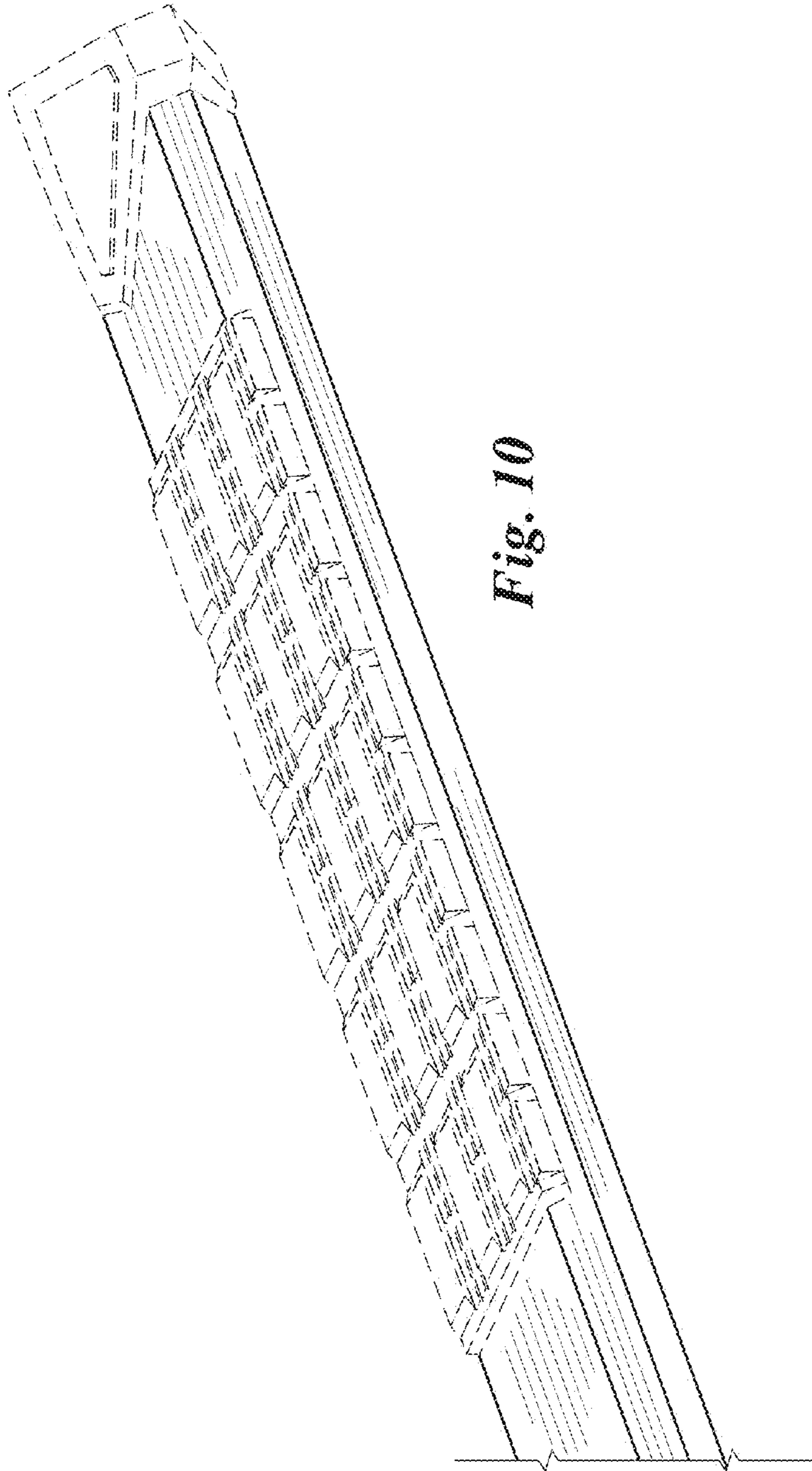

Fig. 10

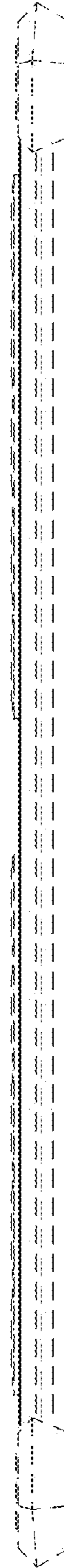

Fig. 8

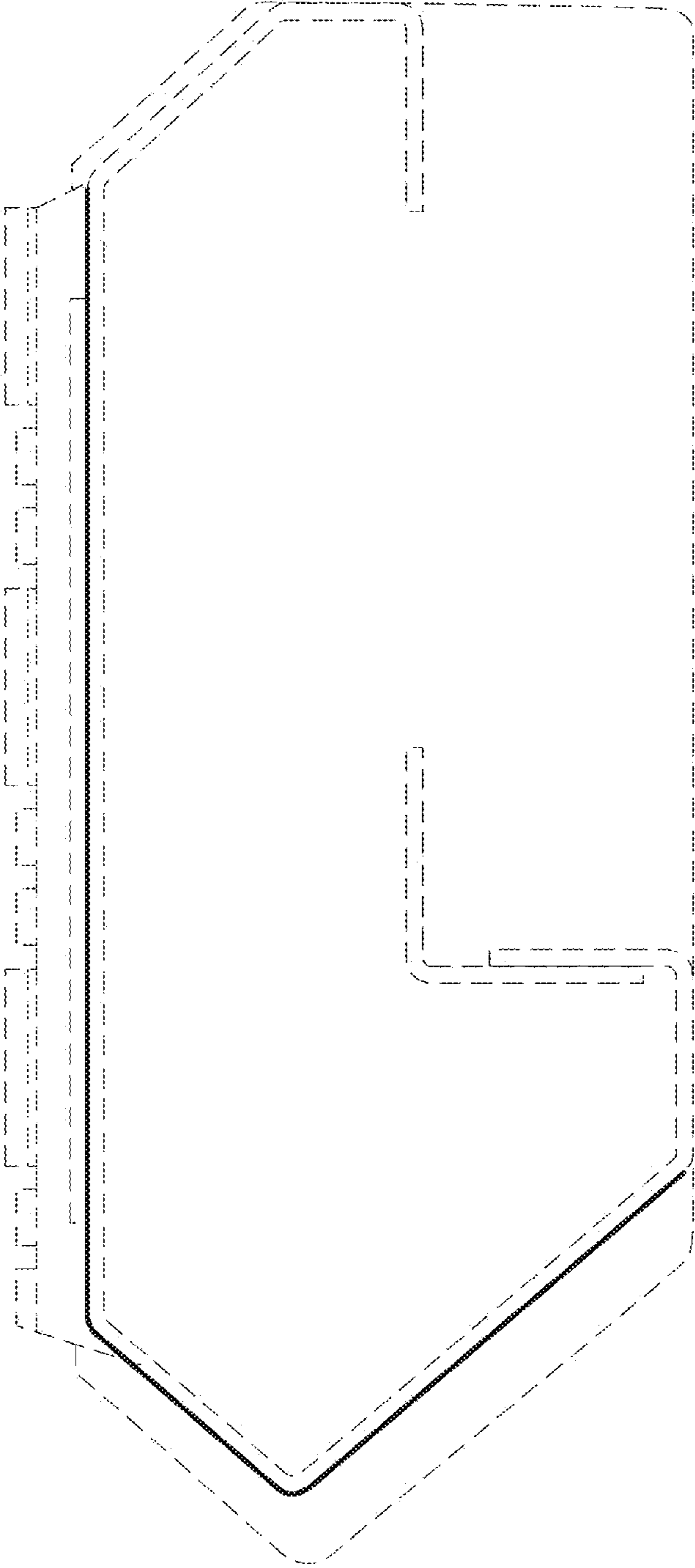

Fig. 11