



US00D739779S

(12) **United States Design Patent**
McKinney

(10) **Patent No.:** **US D739,779 S**
(45) **Date of Patent:** **** Sep. 29, 2015**

- (54) **MERCHANDISE DISPLAY STAND**
- (71) Applicant: **InVue Security Products Inc.,**
Charlotte, NC (US)
- (72) Inventor: **Larry T. McKinney,** Huntersville, NC
(US)
- (73) Assignee: **InVue Security Products Inc.,**
Charlotte, NC (US)
- (**) Term: **14 Years**
- (21) Appl. No.: **29/440,180**
- (22) Filed: **Dec. 19, 2012**
- (51) **LOC (10) Cl.** **10-05**
- (52) **U.S. Cl.**
USPC **D10/106.9**
- (58) **Field of Classification Search**
None
See application file for complete search history.

(56) **References Cited**

U.S. PATENT DOCUMENTS

| | | | | | |
|-----------|------|---------|------------------|-------|------------|
| 5,235,168 | A * | 8/1993 | Bobba | | 235/462.43 |
| 6,027,277 | A * | 2/2000 | Leyden et al. | | 403/291 |
| D459,670 | S * | 7/2002 | Bergstrom | | D10/104.1 |
| 7,522,047 | B2 * | 4/2009 | Belden et al. | | 340/568.1 |
| D616,778 | S * | 6/2010 | Marszalek et al. | | D10/106.9 |
| D669,380 | S * | 10/2012 | Kong et al. | | D10/104.1 |

2009/0058643 A1* 3/2009 Groth 340/568.1
* cited by examiner

Primary Examiner — George D Kirschbaum
(74) *Attorney, Agent, or Firm* — InVue Security Products Inc.

(57) **CLAIM**
The ornamental design for a merchandise display stand, as shown and described.

DESCRIPTION

FIG. 1 is a right front perspective view of a merchandise display stand, showing my new design.
 FIG. 2 is a right side elevation view of the merchandise display stand of FIG. 1.
 FIG. 3 is a left side elevation view of the merchandise display stand of FIG. 1.
 FIG. 4 is a front elevation view of the merchandise display stand of FIG. 1.
 FIG. 5 is a rear elevation view of the merchandise display stand of FIG. 1.
 FIG. 6 is a top plan view of the merchandise display stand of FIG. 1; and,
 FIG. 7 is a bottom plan view of the merchandise display stand of FIG. 1.
 In the drawings, the broken line showing of a cell phone, as well as elements of a merchandise display stand, depict environmental subject matter and form no part of the claimed design. The dash-dot-dash lines represent the boundaries of the claimed design.

1 Claim, 7 Drawing Sheets

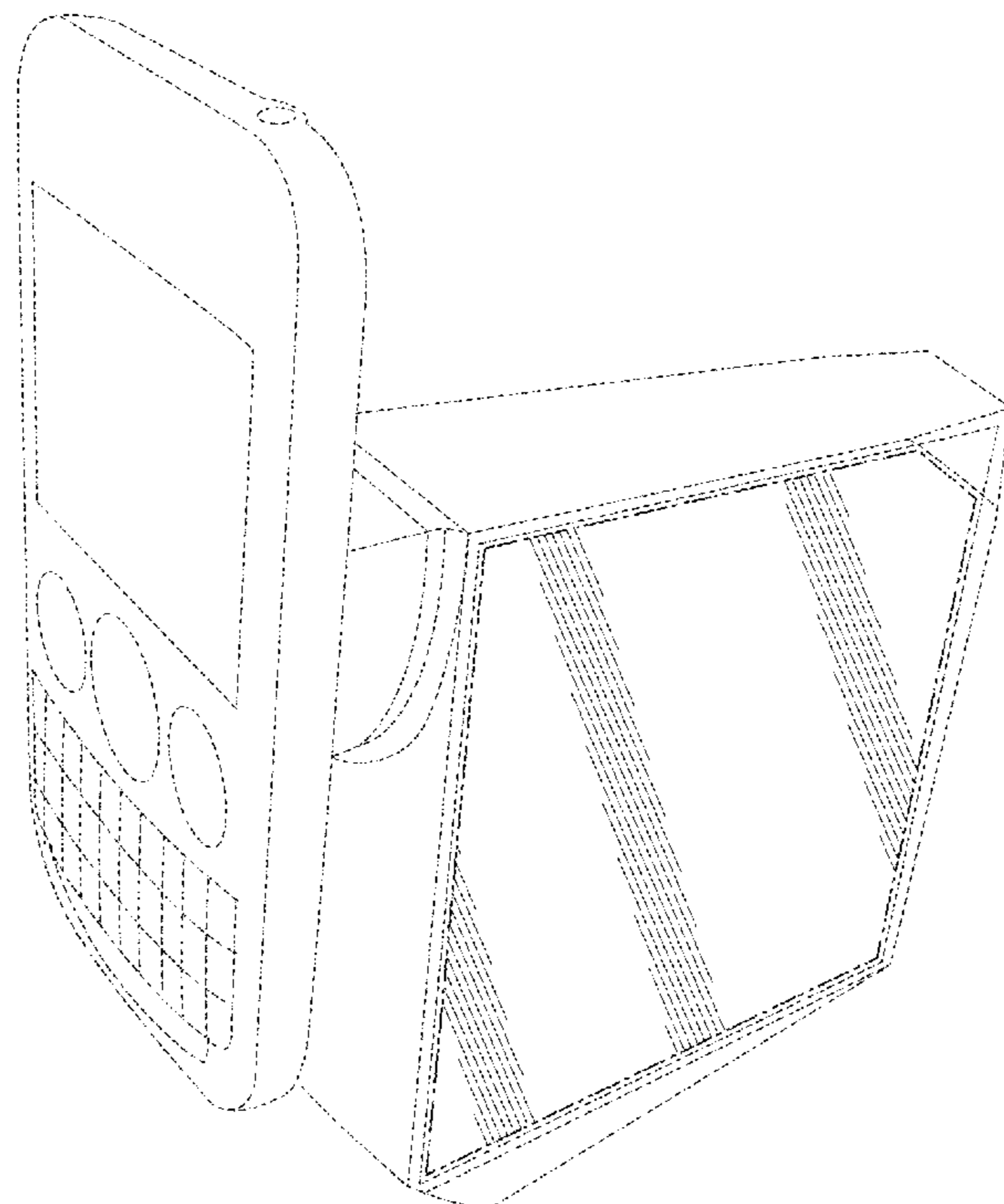

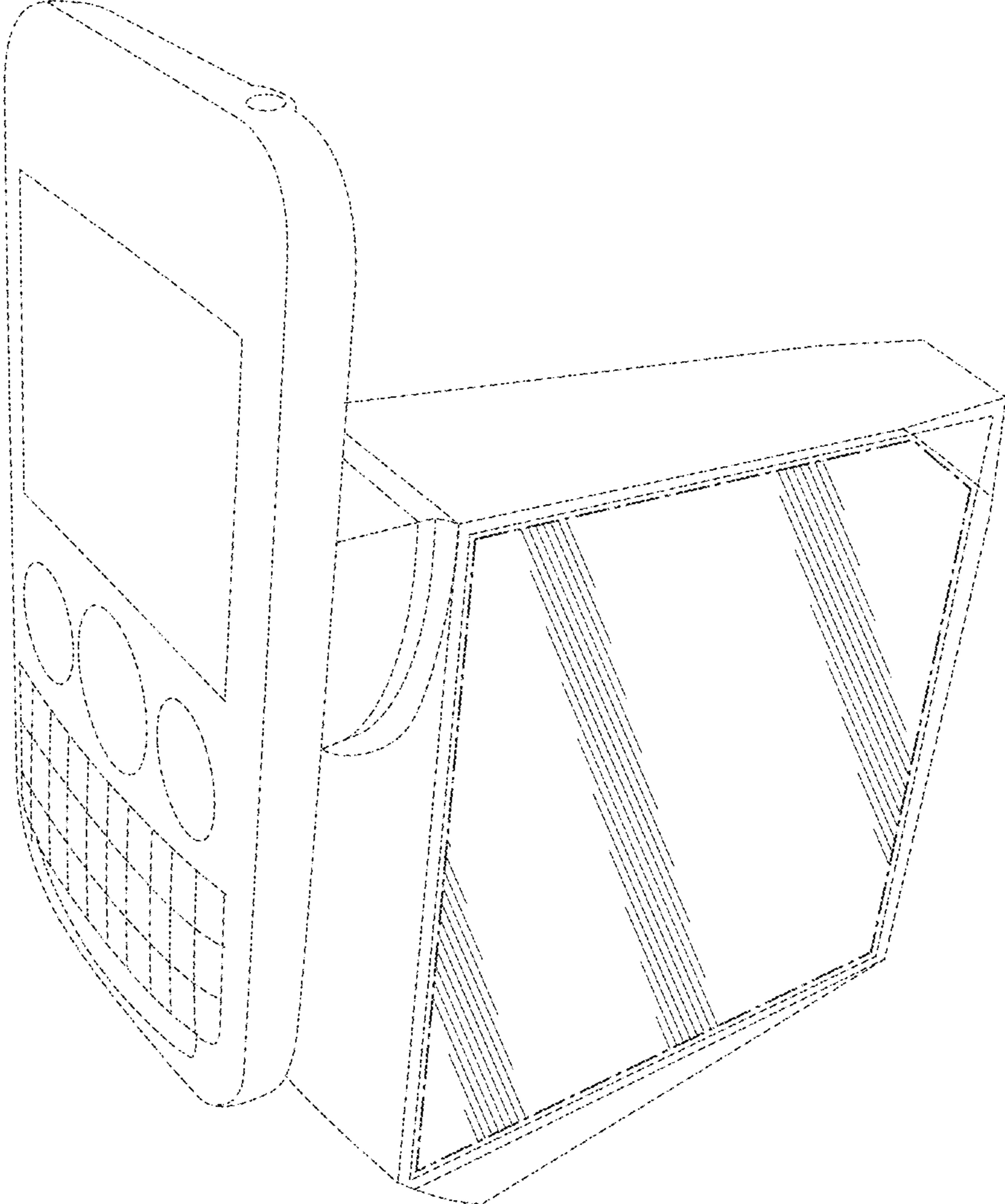

FIG. 1

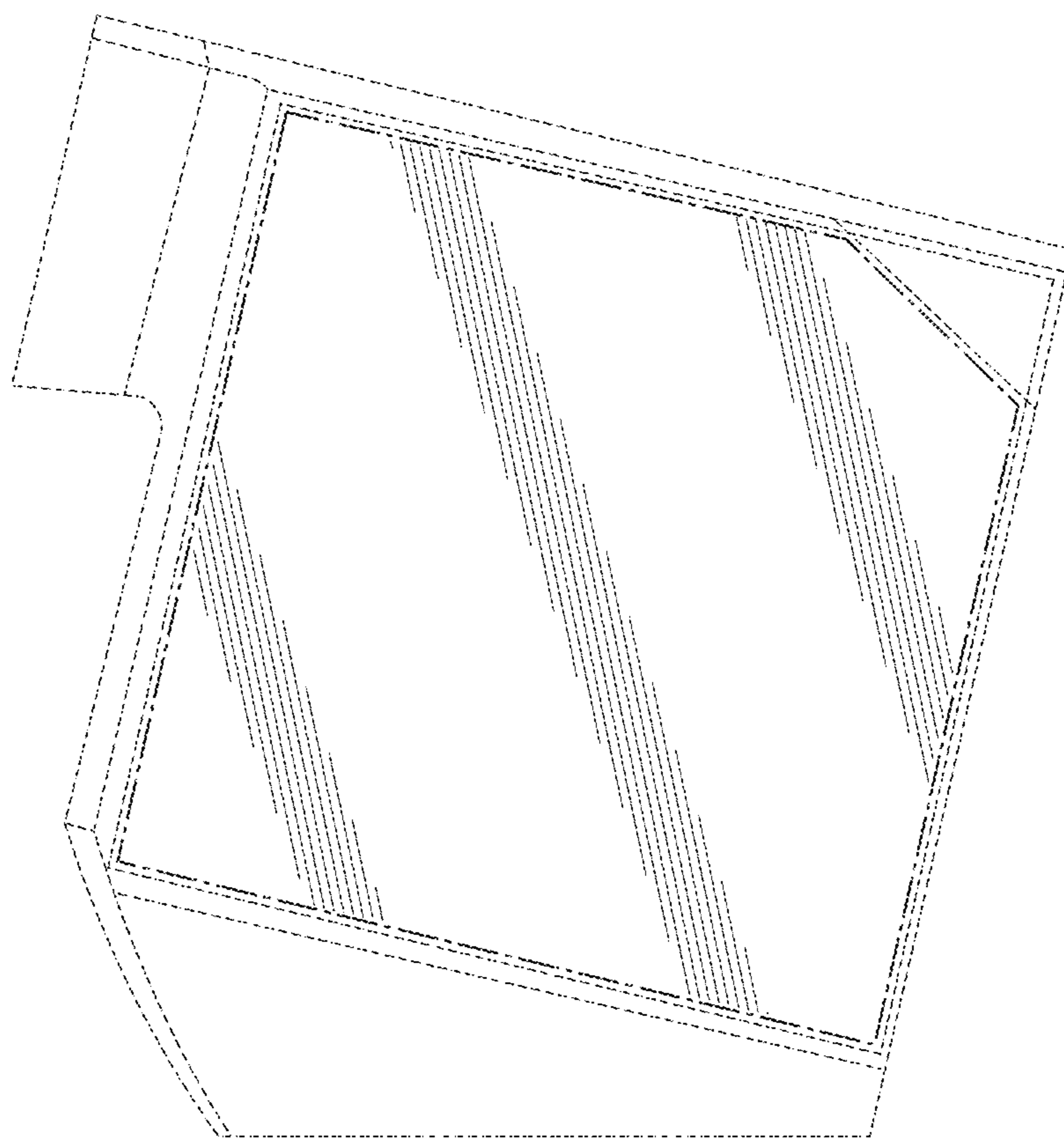

FIG. 2

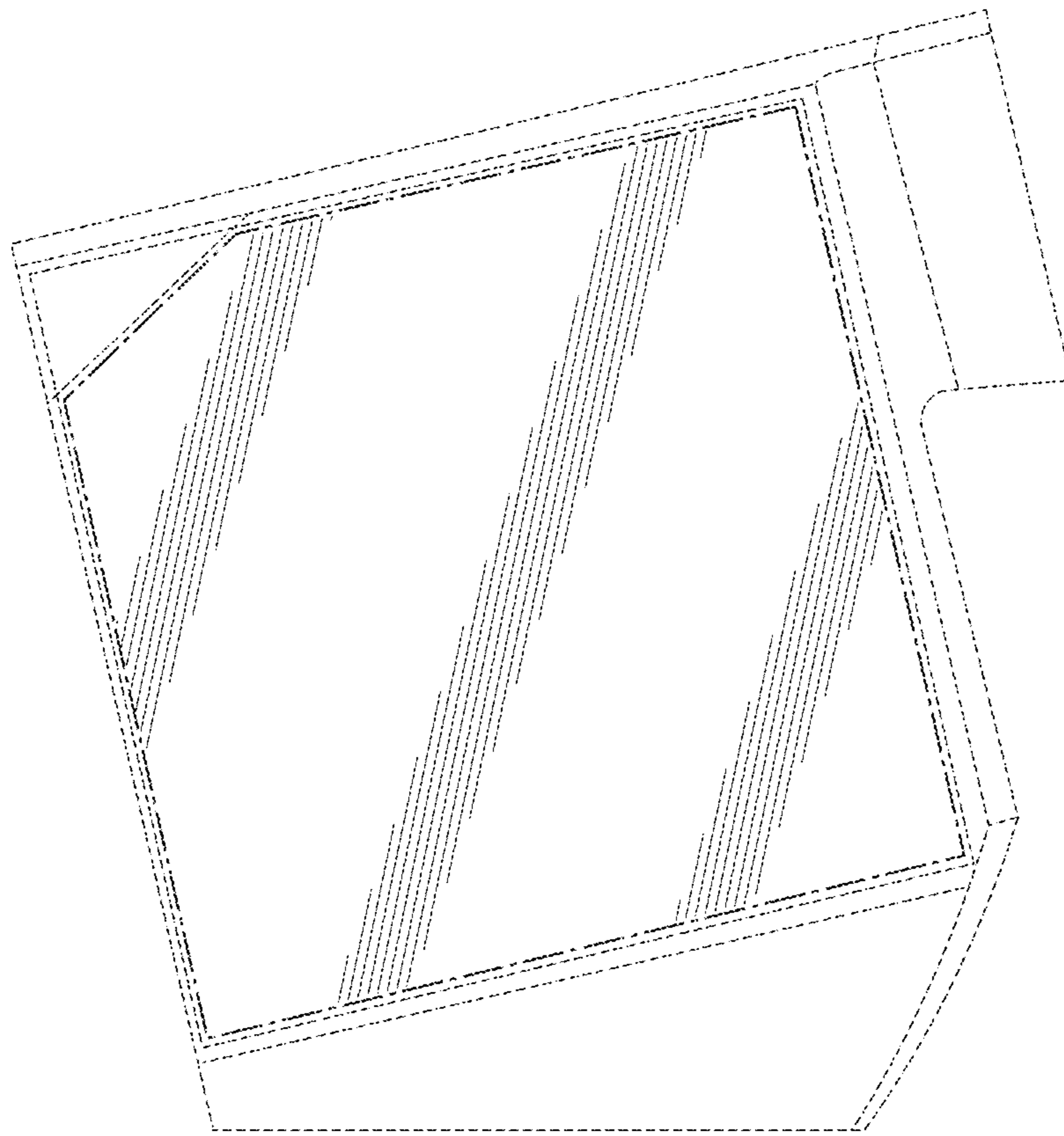

FIG. 3

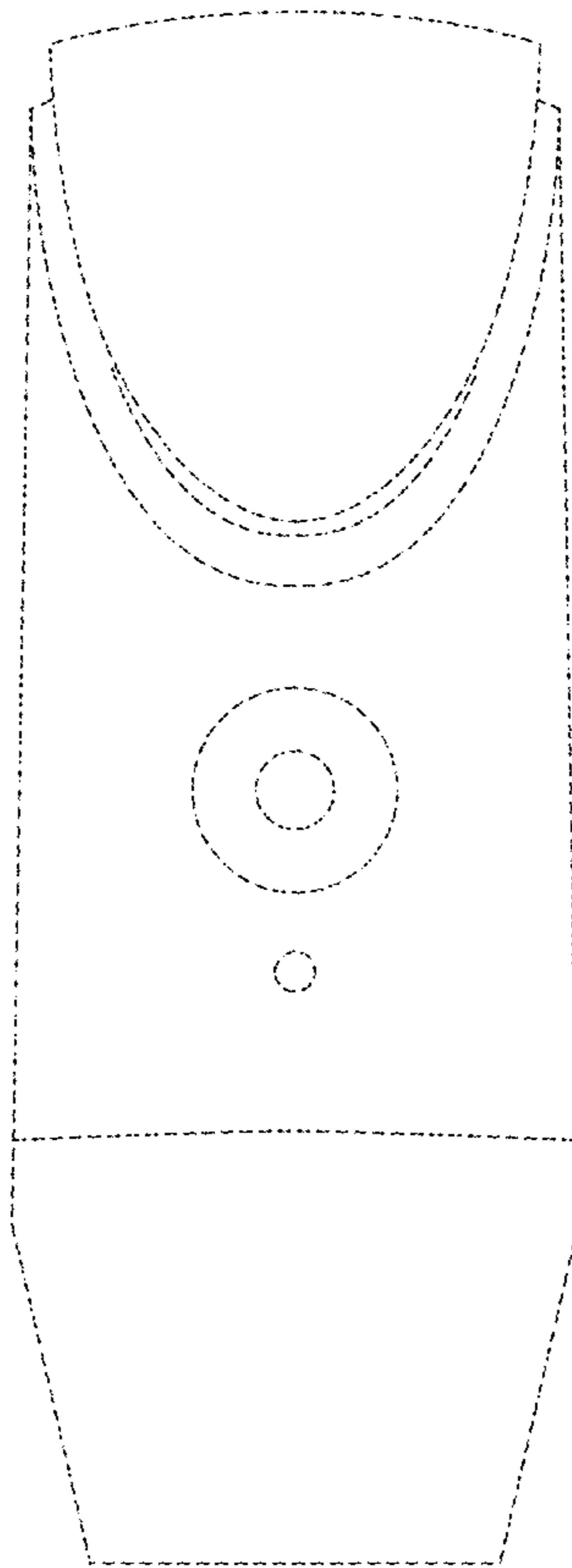

FIG. 4

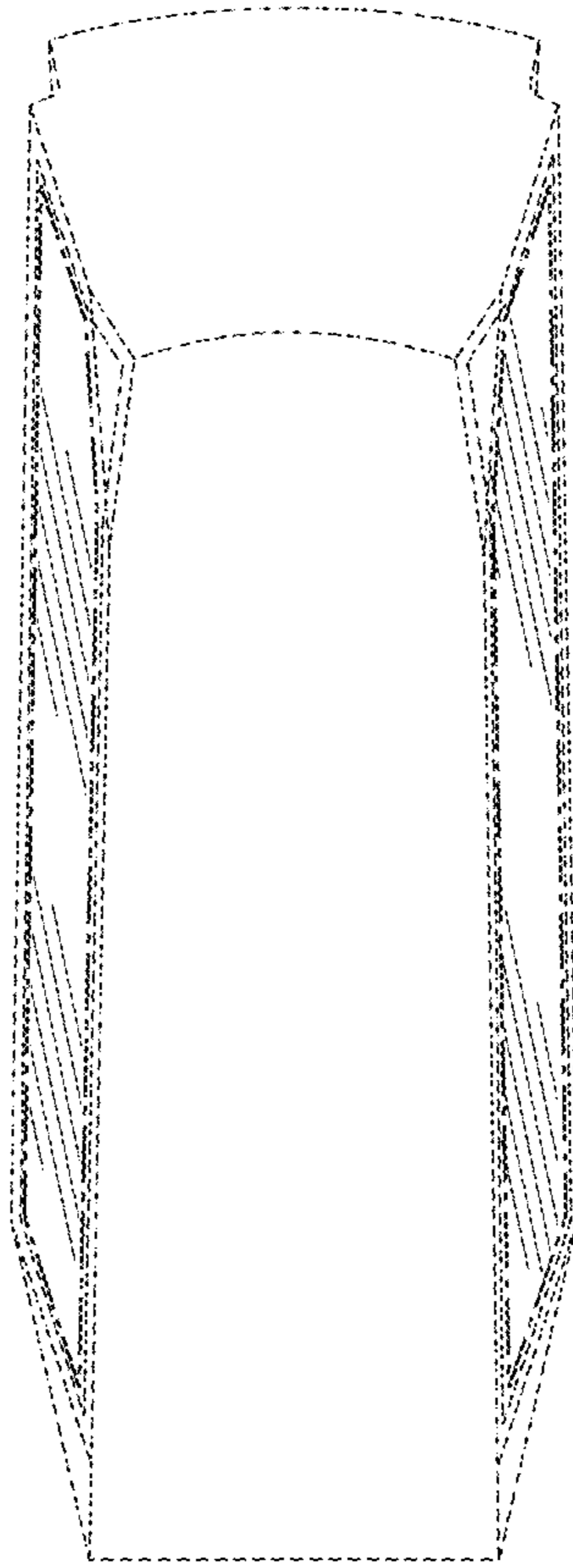

FIG. 5

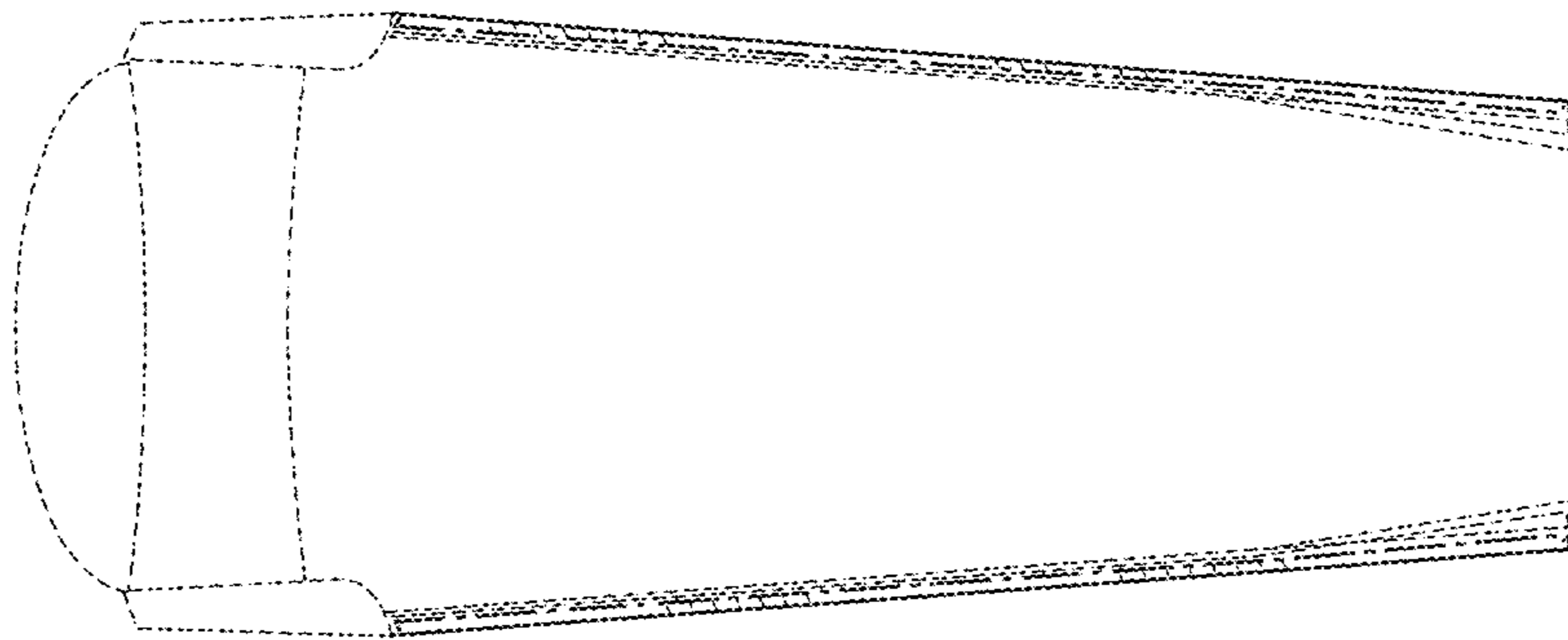

FIG. 6

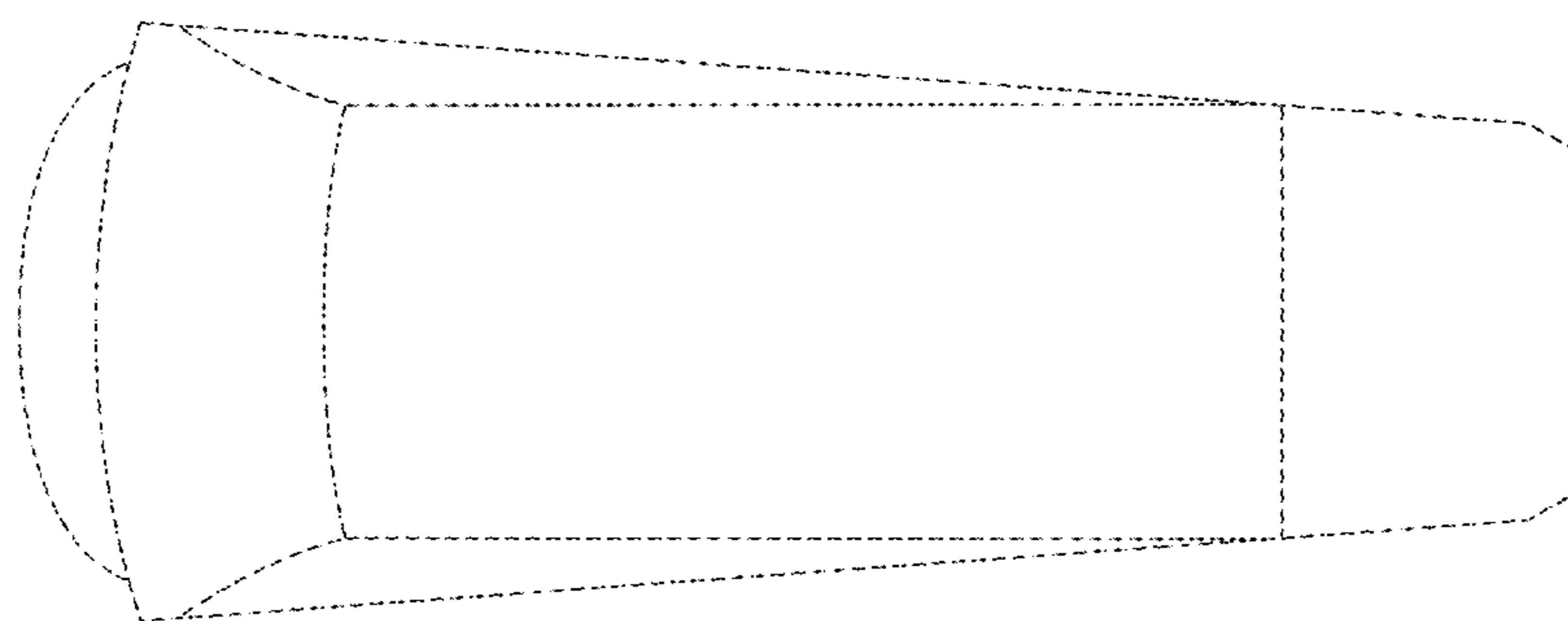

FIG. 7