

US00D739728S

(12) **United States Design Patent**
Schorre

(10) **Patent No.:** **US D739,728 S**

(45) **Date of Patent:** **** Sep. 29, 2015**

(54) **PULL TAB**

(71) Applicant: **Christopher P Schorre**, Austin, TX
(US)

(72) Inventor: **Christopher P Schorre**, Austin, TX
(US)

(73) Assignee: **Christopher P Schorre**, Austin, TX
(US)

(**) Term: **14 Years**

(21) Appl. No.: **29/467,506**

(22) Filed: **Sep. 19, 2013**

Related U.S. Application Data

(63) Continuation of application No. 13/305,097, filed on
Nov. 28, 2011, now Pat. No. 8,695,245.

(51) **LOC (10) Cl.** **09-07**

(52) **U.S. Cl.**

USPC **D9/438**

(58) **Field of Classification Search**

USPC D9/434, 435, 438, 499; D7/396.2,
D7/392.1, 541, 553.2, 605, 627; 220/272,
220/470; 229/123.2, 406

See application file for complete search history.

(56) **References Cited**

U.S. PATENT DOCUMENTS

2,870,935	A *	1/1959	Houghtelling	220/270
3,822,496	A	7/1974	Minder		
5,316,166	A	5/1994	Pavely et al.		
D385,493	S *	10/1997	Zhang	D9/449
5,799,815	A	9/1998	Lang		
D474,967	S	5/2003	Kaneko		
D535,877	S *	1/2007	Tanninen et al.	D9/438
D556,036	S *	11/2007	Lohrman et al.	D9/438
D625,184	S *	10/2010	Forrest et al.	D9/438

8,146,758	B1 *	4/2012	Peres	215/6
8,695,245	B2 *	4/2014	Schorre	40/307
2005/0258175	A1	11/2005	Robertson		
2006/0196875	A1	9/2006	Cherian		
2010/0193519	A1	8/2010	Forrest		
2012/0273492	A1	11/2012	Werth et al.		

FOREIGN PATENT DOCUMENTS

JP	59 133441	B1	9/1984
JP	3 014455	B1	1/1991

OTHER PUBLICATIONS

“New Aluminum Can Pull Tab Design Opens Exciting Possibilities
for Beverage Producers and Brand Marketers”, article in PRWeb.
May 7, 2014, 2 pages. Found online at <http://www.prweb.com/releases/2014/05/prweb11827176.htm>.*

WingTab: Wide format pull tabs for beverage brand promotion—
“Take advantage of your top marketing asset”, thewingtab.com, ©
2014, 3 pages. Found online at <http://www.thewingtab.com/beverage-companies/>.*

ISR/WO for related PCT/IB2012/056729, mailed on Mar. 13, 2013.

* cited by examiner

Primary Examiner — Robert M Spear

(74) *Attorney, Agent, or Firm* — Pierson IP, PLLC

(57) **CLAIM**

The ornamental design for a pull tab, as shown and described.

DESCRIPTION

FIG. 1 is a top perspective view of a pull tab showing my new
design thereof;

FIG. 2 is a second top perspective view thereof;

FIG. 3 is a bottom perspective view thereof; and,

FIG. 4 is a top plan view thereof shown in an environment of
use on a beverage can.

Elements shown in broken lines show environmental struc-
tures of a beverage can and form no part of my design.

1 Claim, 4 Drawing Sheets

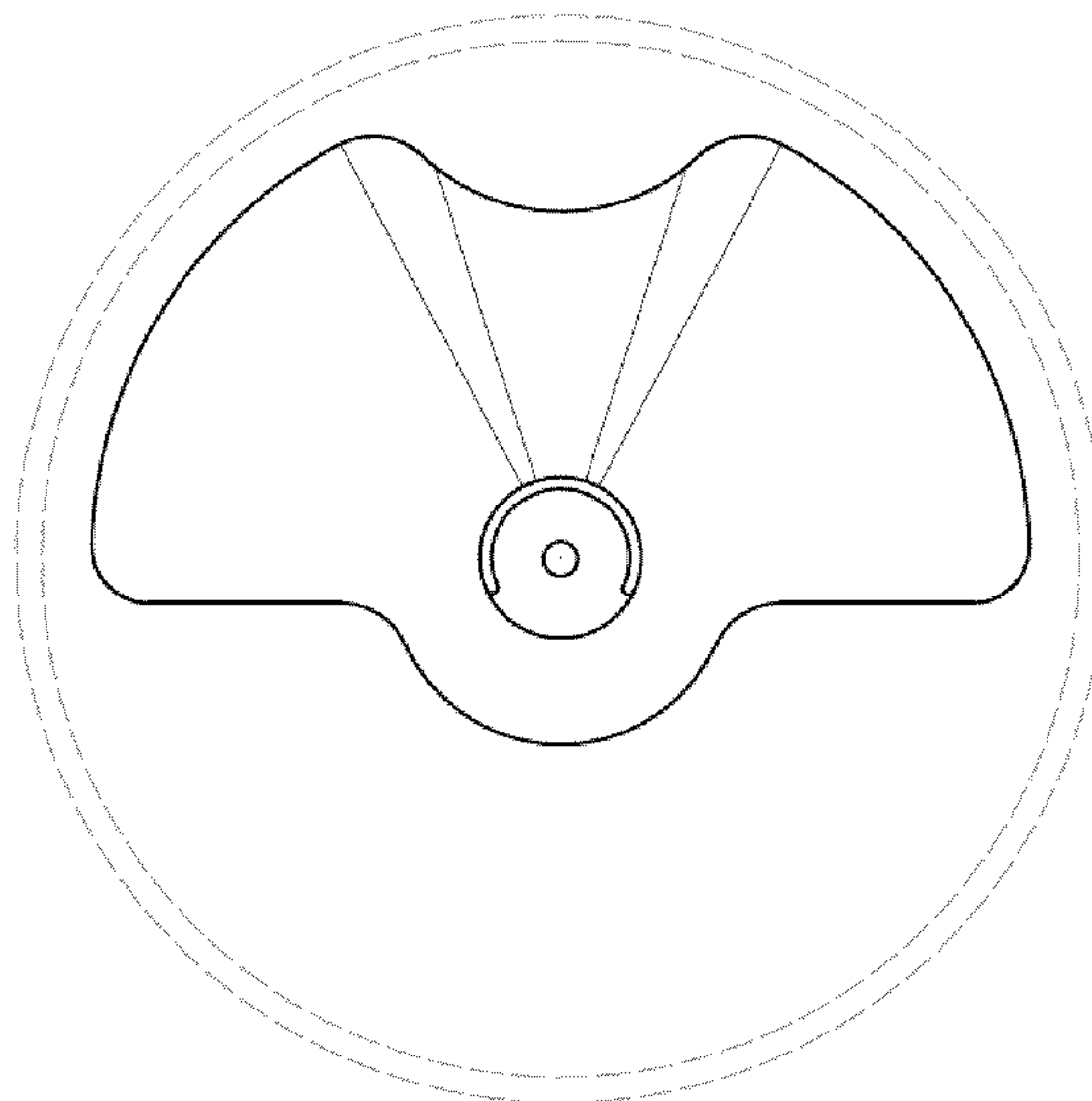
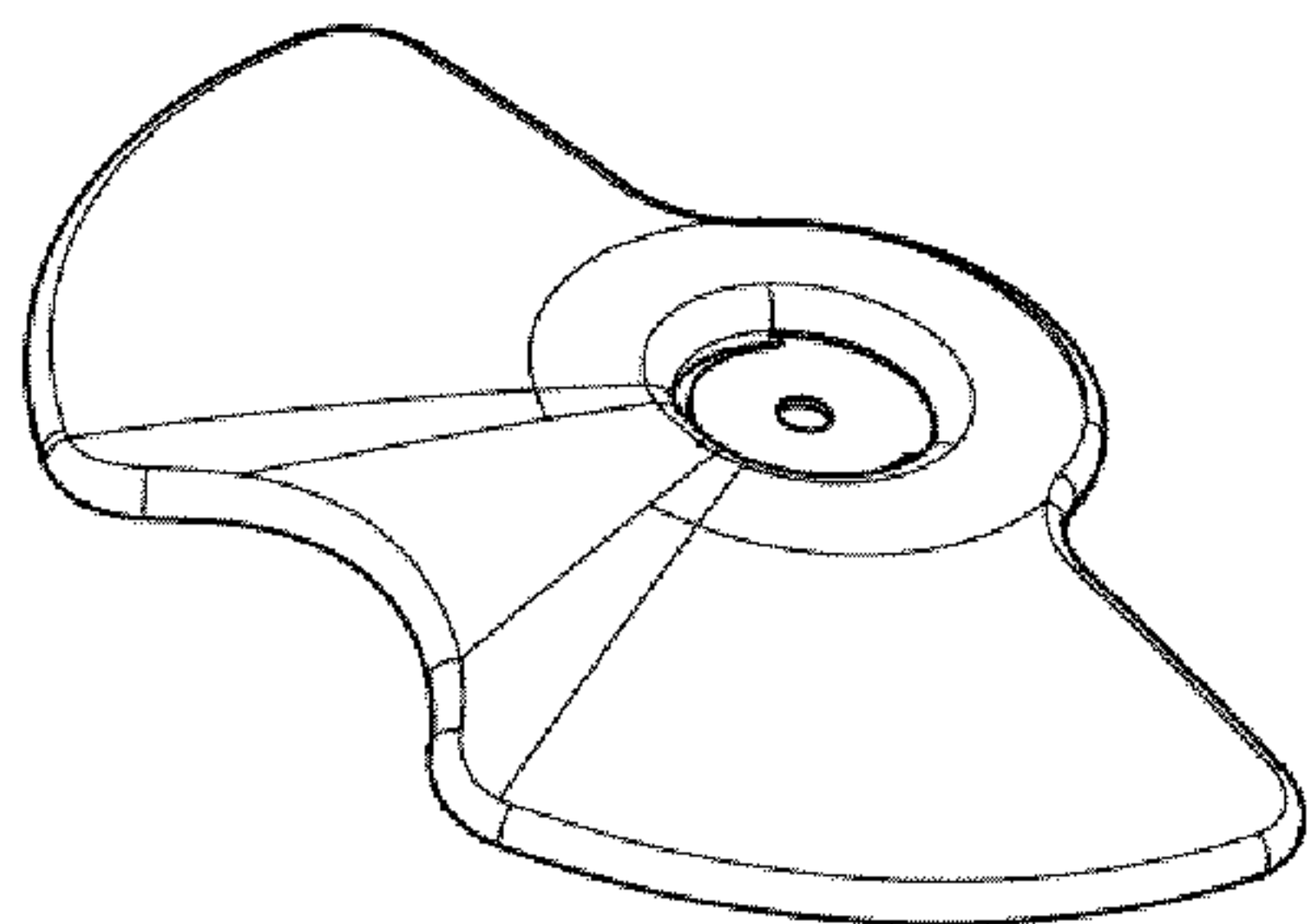

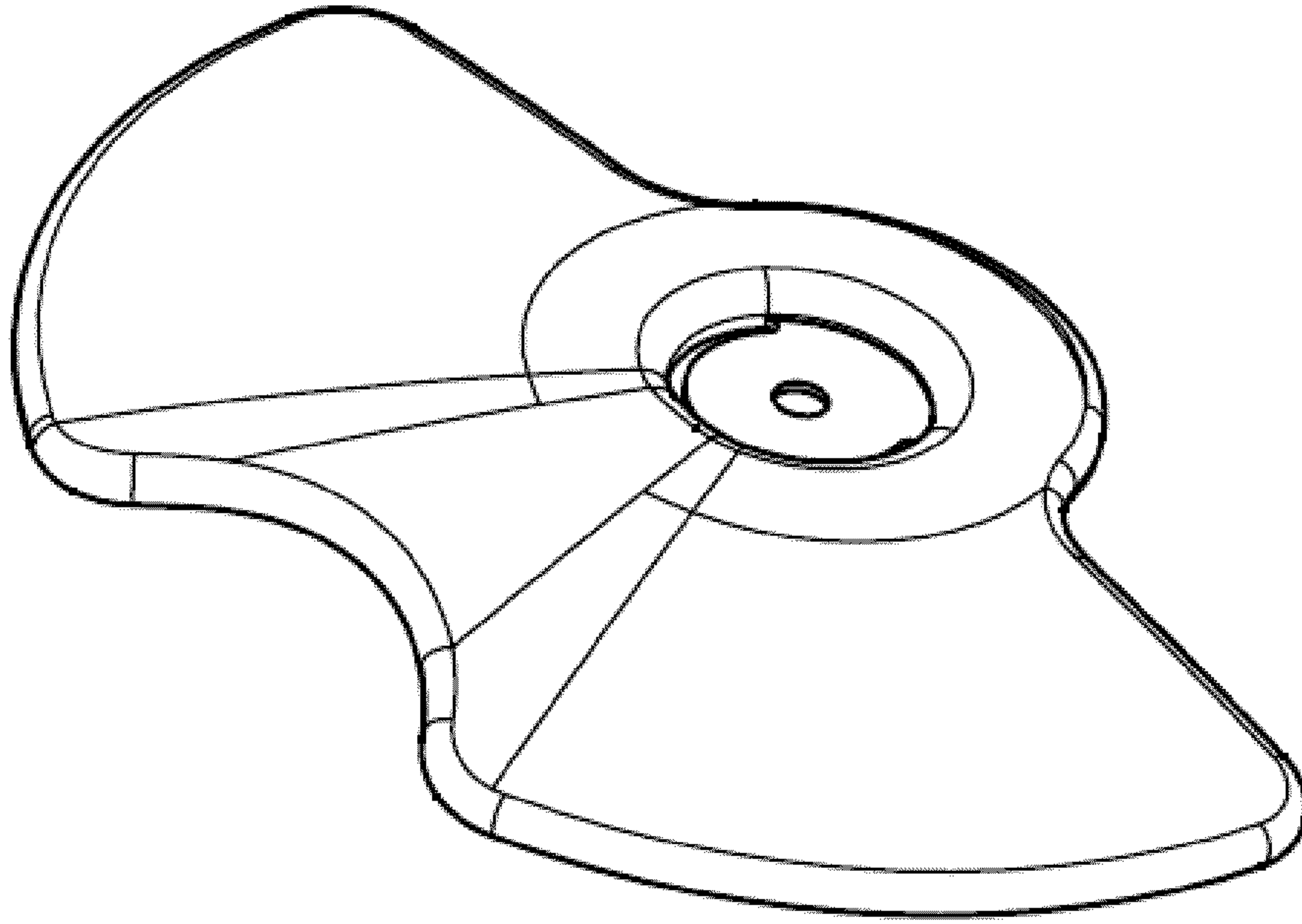

FIGURE 1

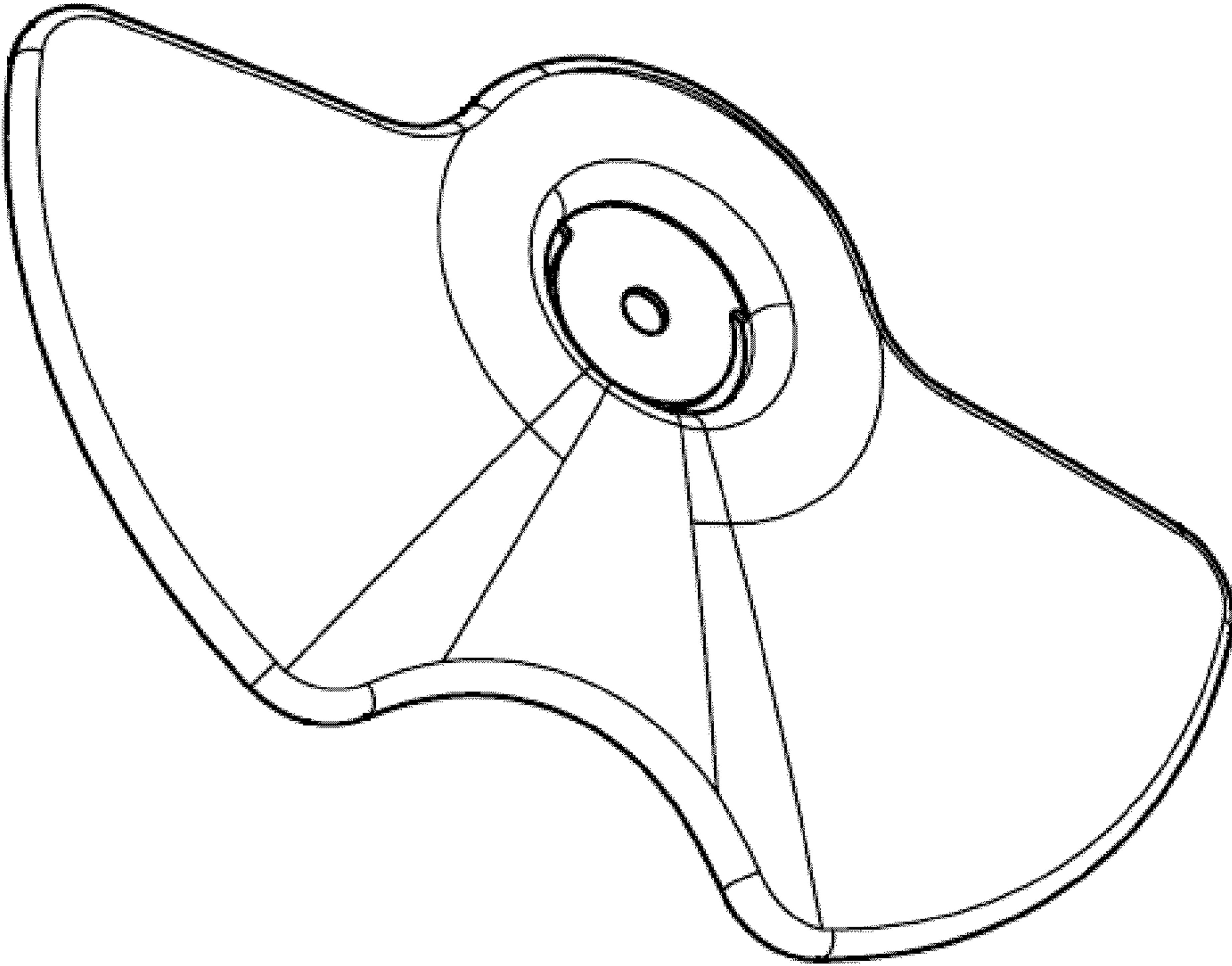

FIGURE 2

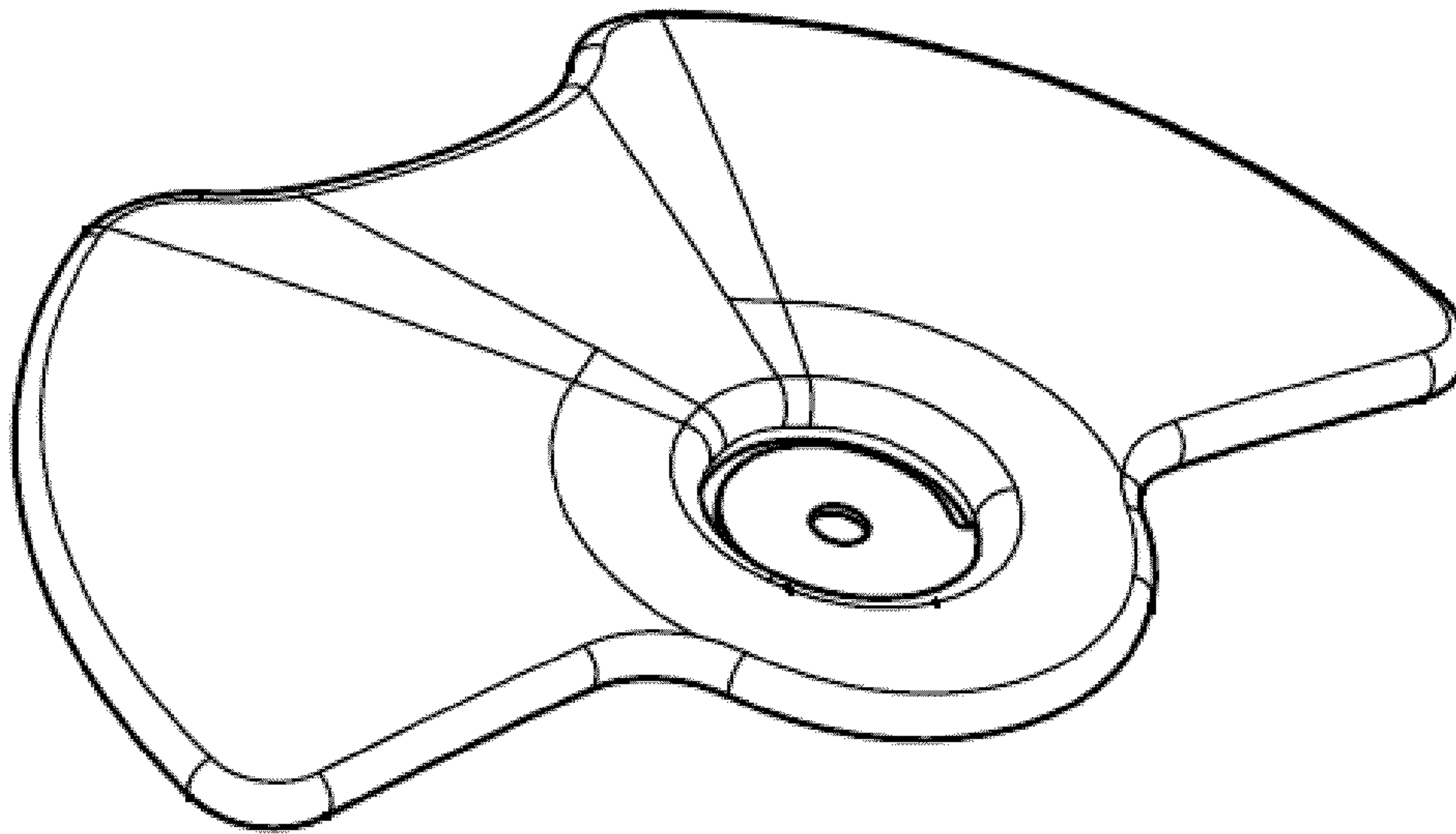

FIGURE 3

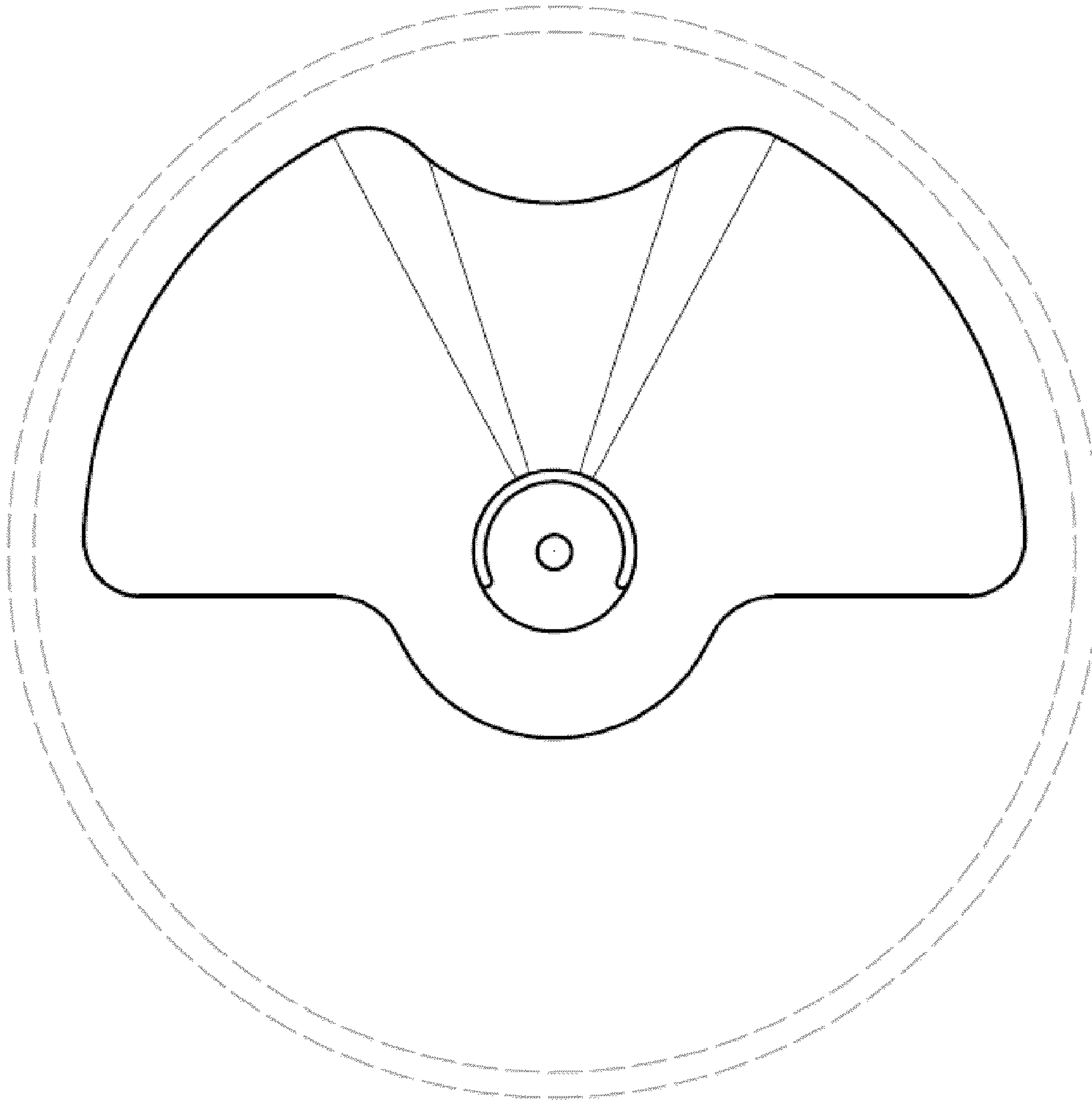

FIGURE 4