



US00D739577S

(12) **United States Design Patent**
Kani

(10) **Patent No.:** **US D739,577 S**

(45) **Date of Patent:** **** Sep. 22, 2015**

(54) **LAMP FOR A VEHICLE**

FOREIGN PATENT DOCUMENTS

(71) Applicant: **PIAA CORPORATION**, Bunkyo-ku,
Tokyo (JP)

CN 302156584 S 10/2012
JP 1443959 5/2012
RU 84765 S 5/2012

(72) Inventor: **Gen Kani**, Tokyo (JP)

* cited by examiner

(73) Assignee: **PIAA CORPORATION**, Tokyo (JP)

Primary Examiner — Wan Laymon

(**) Term: **14 Years**

(74) *Attorney, Agent, or Firm* — Nath, Goldberg & Meyer;
Jerald L. Meyer

(21) Appl. No.: **29/466,975**

(57) **CLAIM**

The ornamental design for the lamp for a vehicle, as shown and described.

(22) Filed: **Sep. 13, 2013**

(51) **LOC (10) Cl.** **26-06**

(52) **U.S. Cl.**
USPC **D26/28**

DESCRIPTION

(58) **Field of Classification Search**
USPC D26/28-31, 34-36, 63; 362/459-460,
362/464-465, 467, 475-478, 485-487, 427,
362/285, 507, 512, 523
CPC . F21Y 2113/00; F21Y 2103/02; H01L 33/54;
F21S 48/10; F21S 48/1104; F21S 48/1305;
F21V 15/01; F21V 21/14; B60Q 1/18; B60Q
1/0683; B60Q 1/0433; B60Q 1/2626; B60Q
1/04; B62J 6/02; B62J 6/04
See application file for complete search history.

FIG. 1 is a front perspective view of a lamp for a vehicle according to the present invention;
FIG. 2 is a front view thereof;
FIG. 3 is a rear view thereof;
FIG. 4 is a left side view thereof;
FIG. 5 is a right side view thereof;
FIG. 6 is a top plan view thereof;
FIG. 7 is a bottom plan view thereof;
FIG. 8 is a front perspective view of a second embodiment of a lamp for a vehicle according to the present invention;
FIG. 9 is a front view thereof;
FIG. 10 is a rear view thereof;
FIG. 11 is a left side view thereof;
FIG. 12 is a right side view thereof;
FIG. 13 is a top plan view thereof; and,
FIG. 14 is a bottom plan view thereof.
The broken lines in FIGS. 3 and 10 are included for the purpose of illustrating a portion of the lamp for a vehicle that forms no part of the claimed design.

(56) **References Cited**

U.S. PATENT DOCUMENTS

| | | | | |
|--------------|---------|----------------|-------|--------|
| D233,778 S * | 11/1974 | Kennedy et al. | | D26/63 |
| D357,329 S * | 4/1995 | Iacovelli | | D26/28 |
| D510,636 S * | 10/2005 | Yamamoto | | D26/28 |
| D570,009 S * | 5/2008 | Kani et al. | | D26/28 |
| D585,575 S * | 1/2009 | Crispin et al. | | D26/28 |
| D688,400 S * | 8/2013 | Haumann | | D26/28 |
| D708,373 S * | 7/2014 | Kani | | D26/28 |

1 Claim, 12 Drawing Sheets

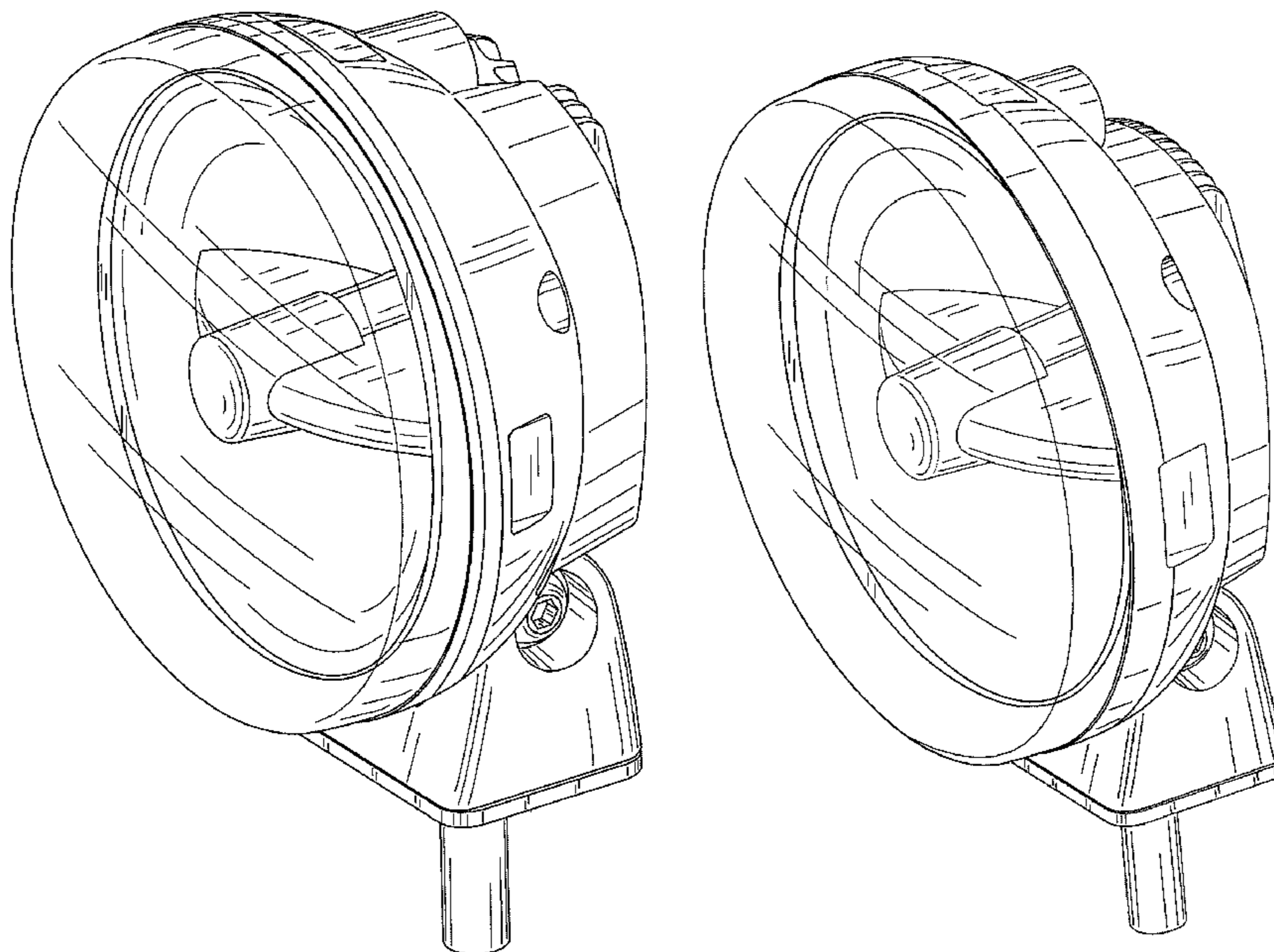

Fig.1

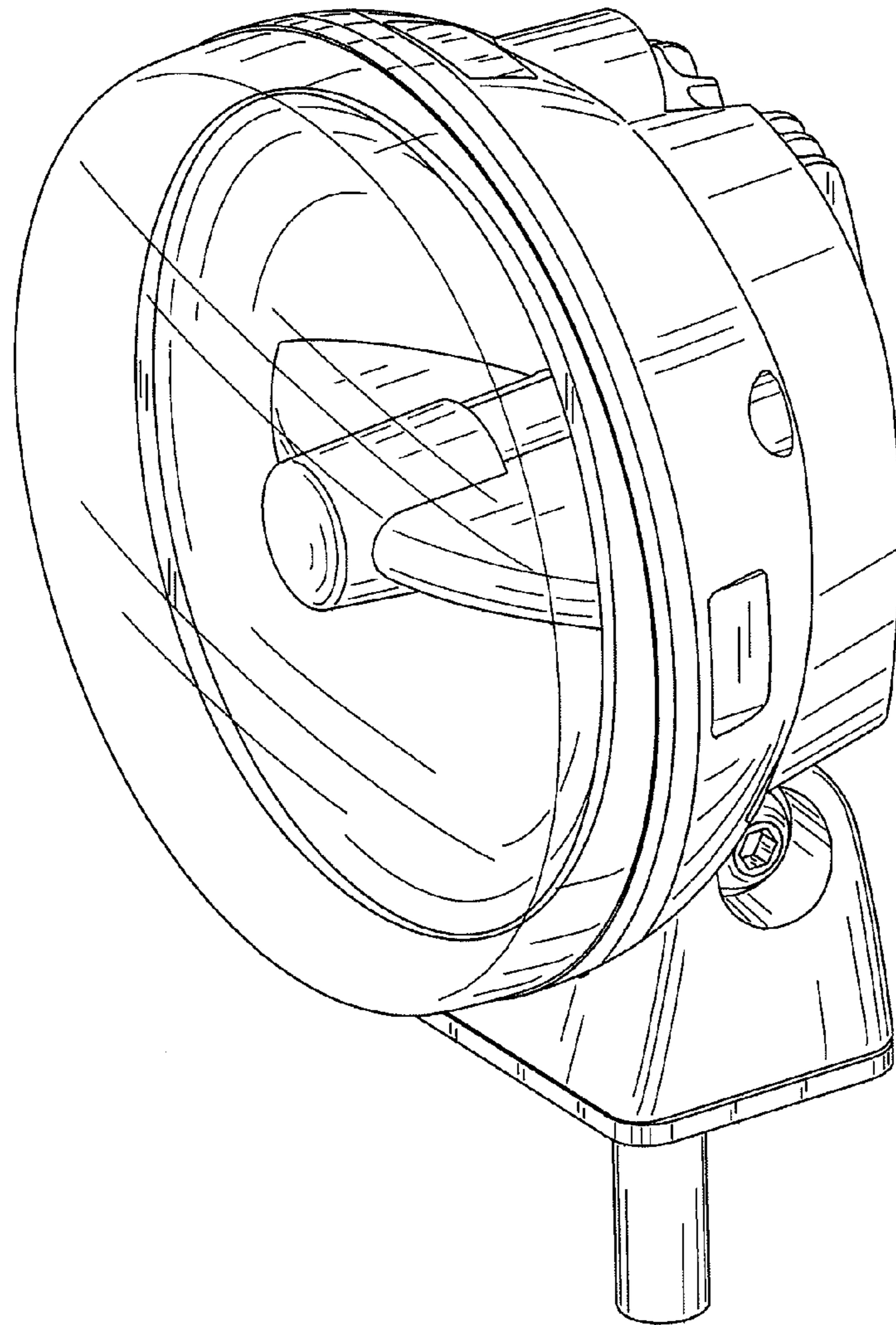

Fig.2

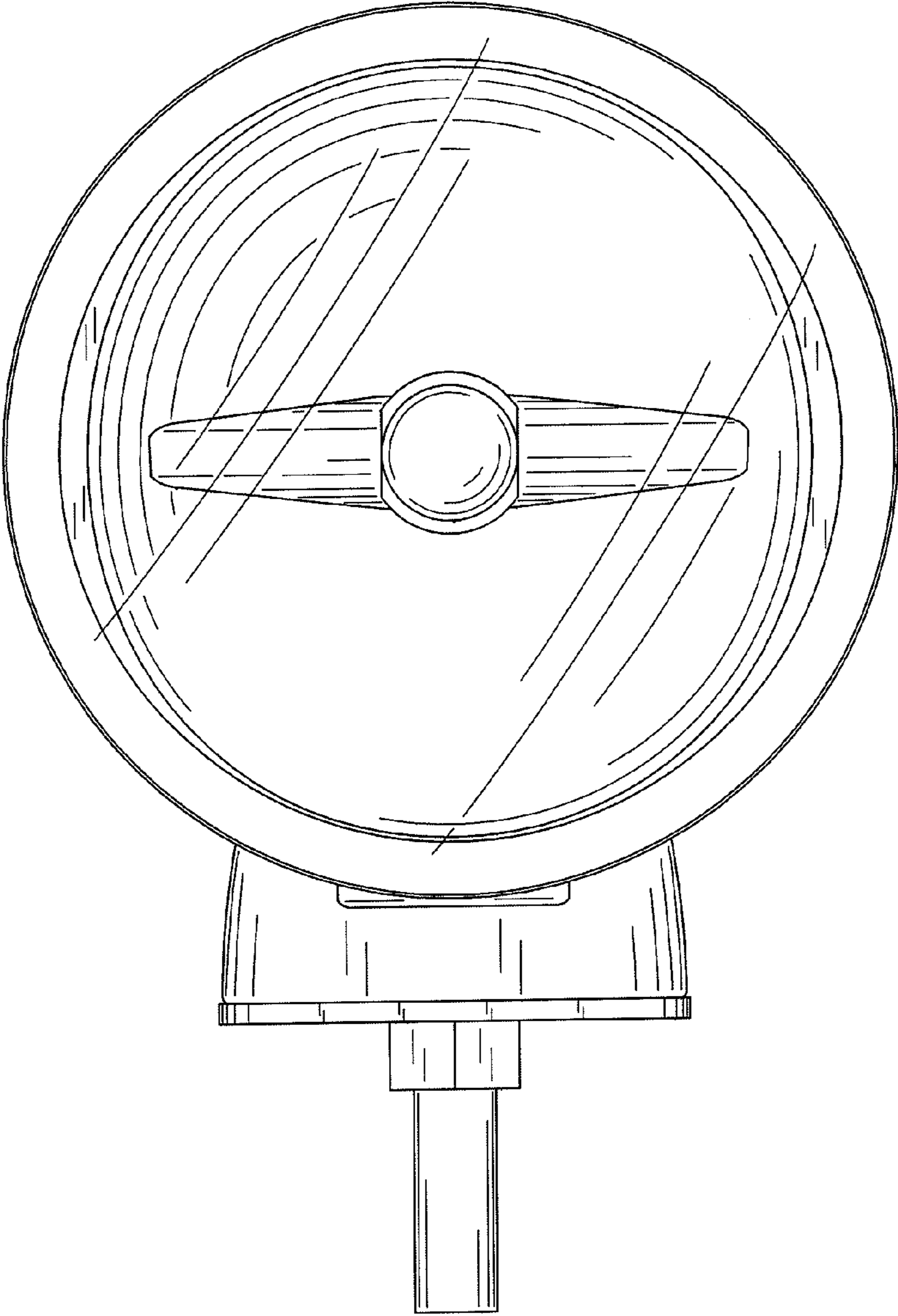

Fig.3

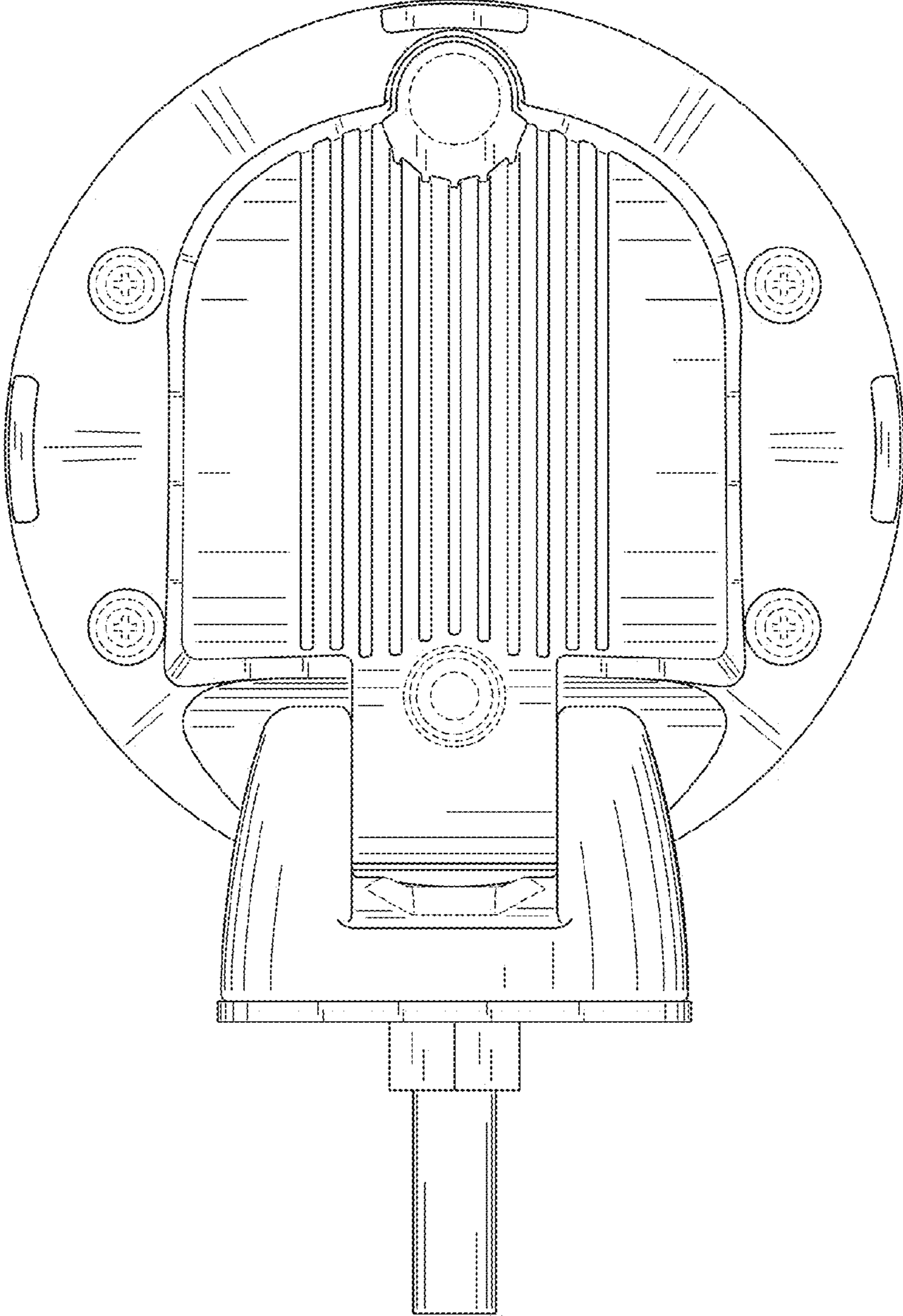

Fig.4

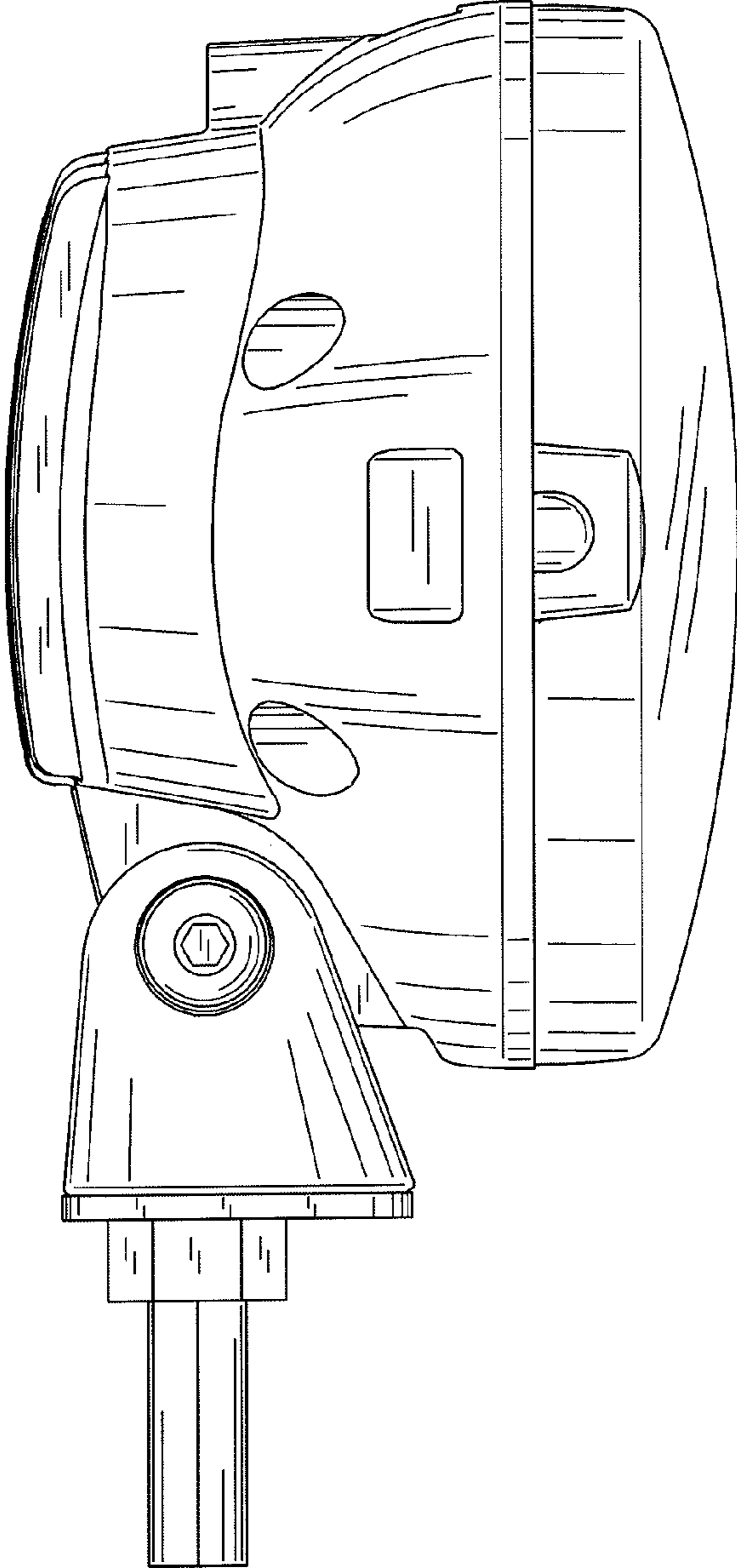

Fig.5

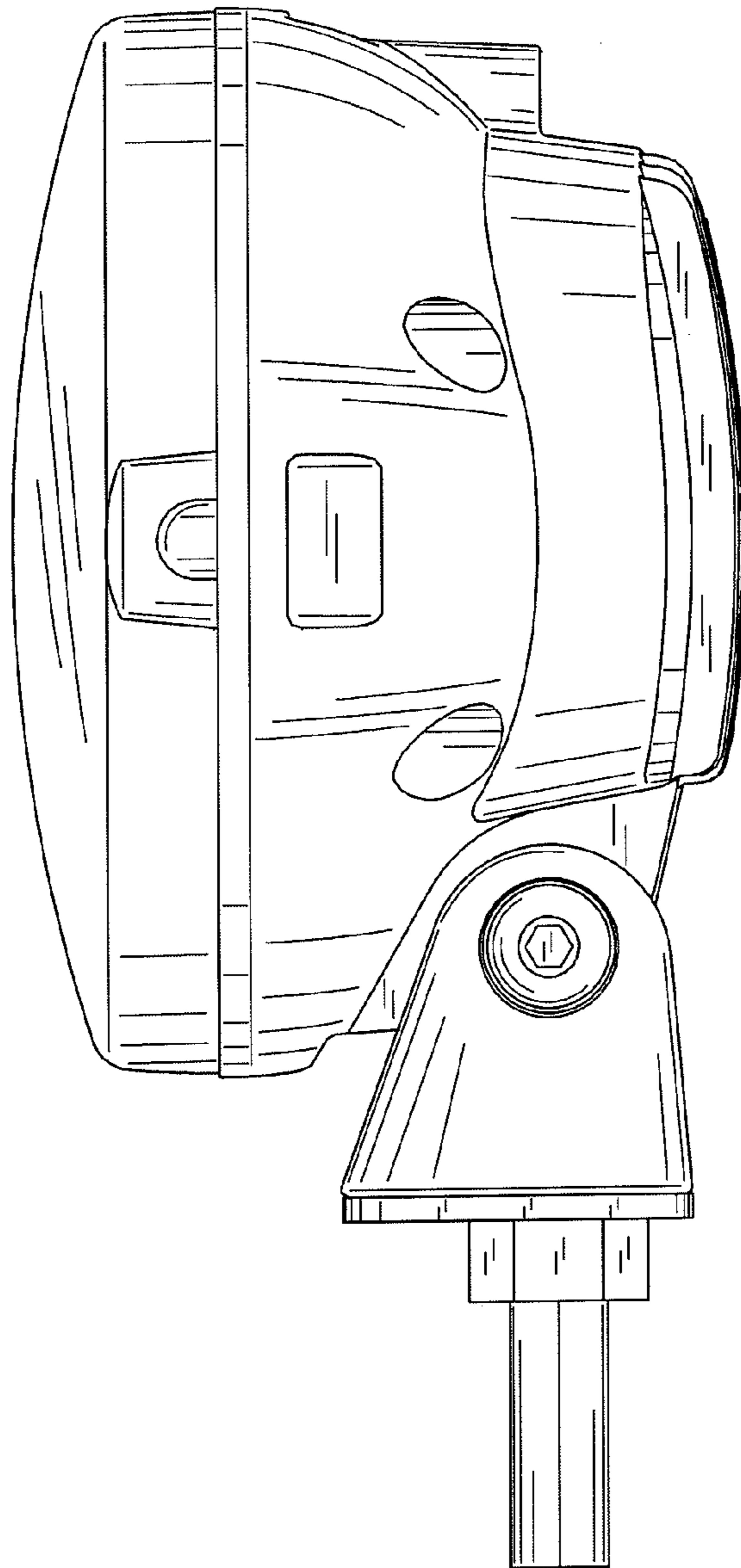

Fig.6

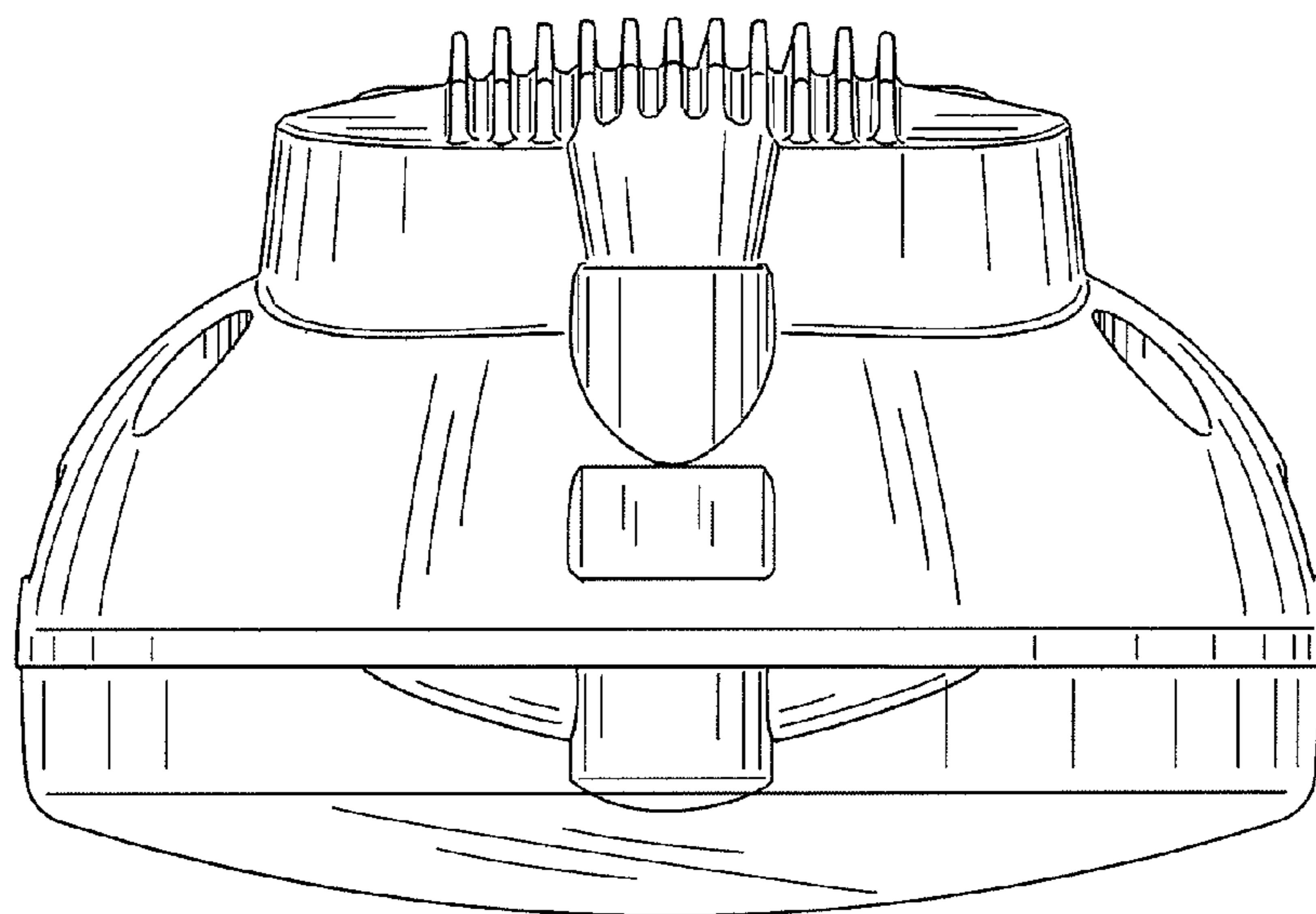

Fig.7

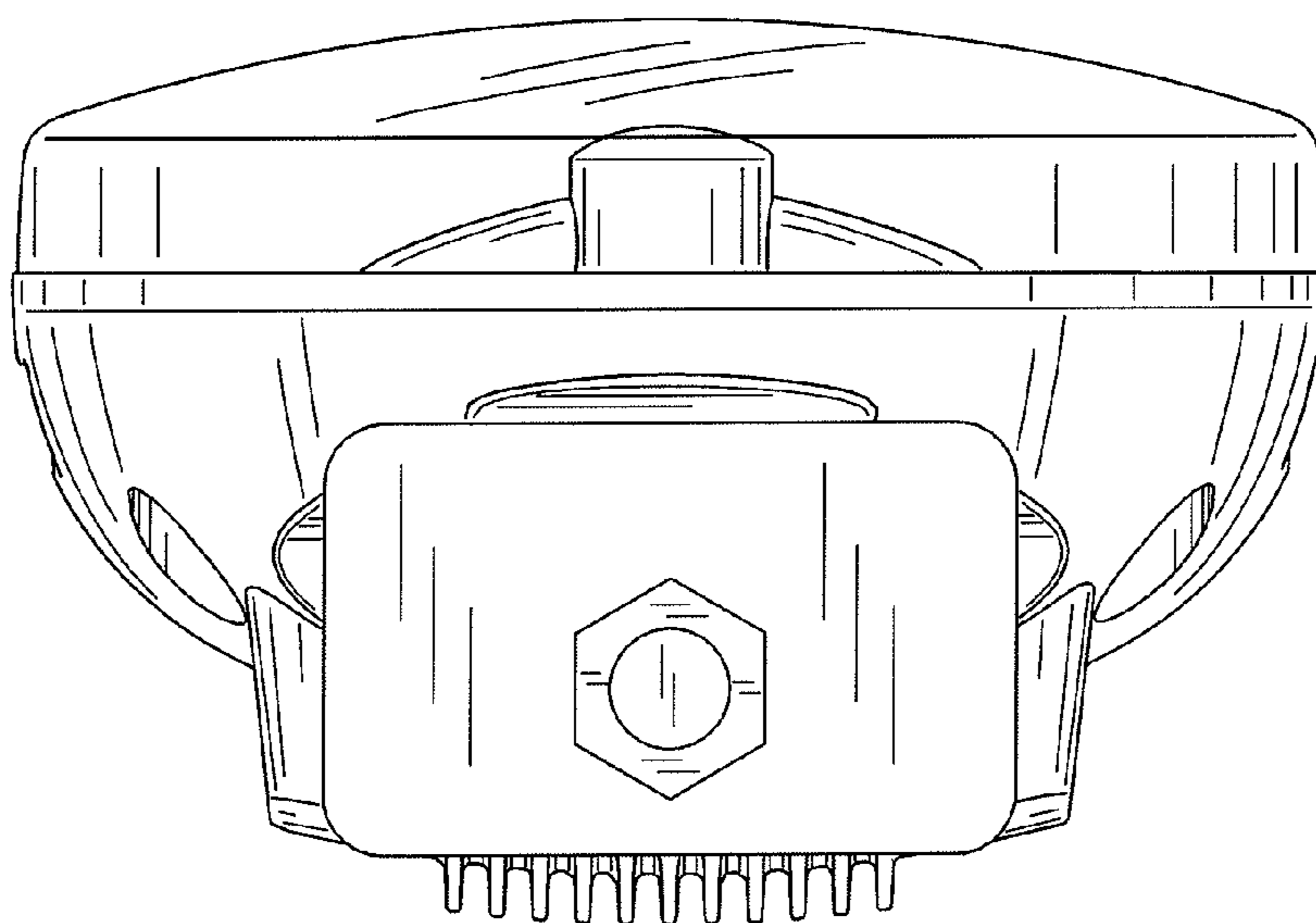

Fig.8

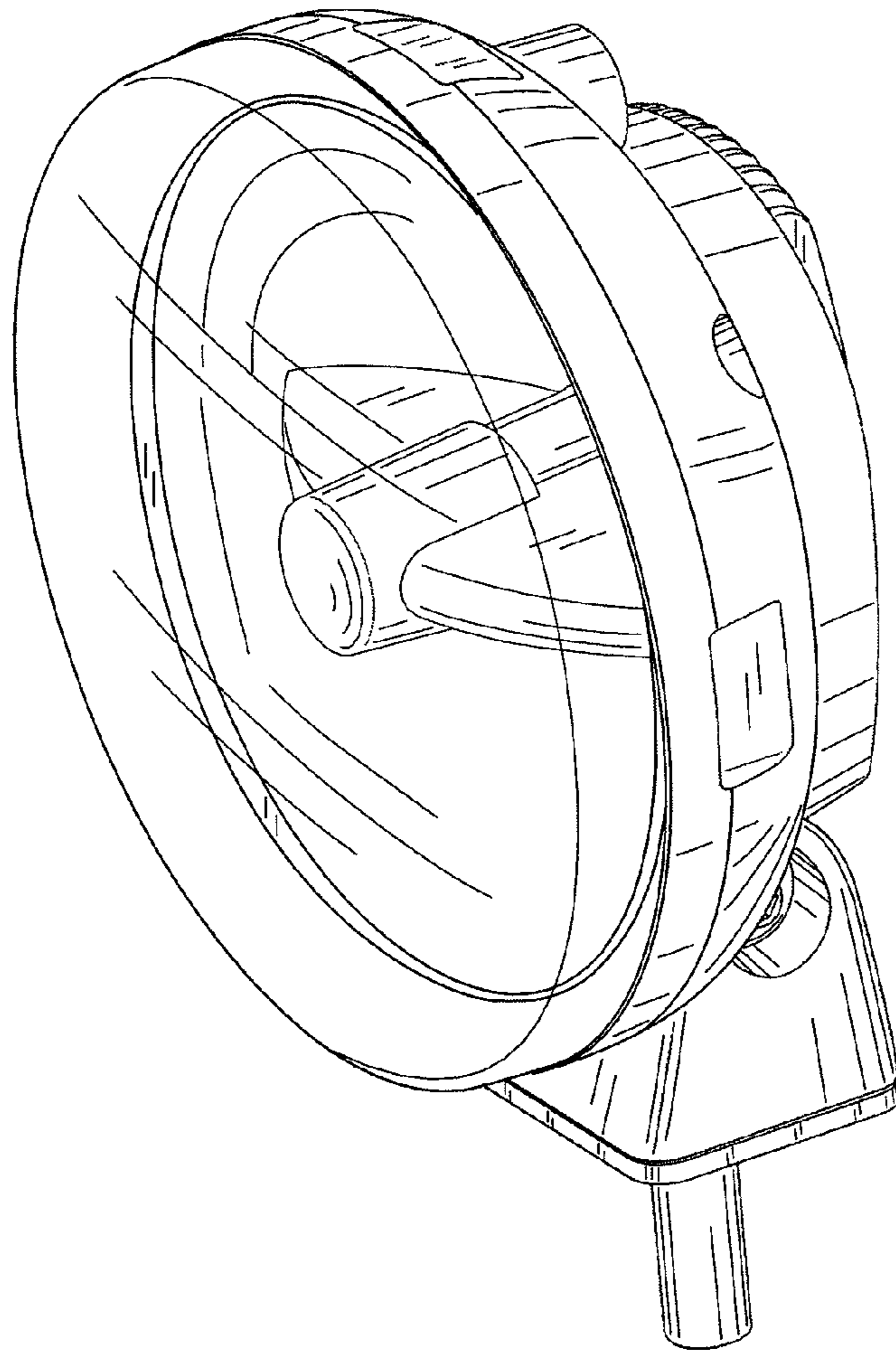

Fig.9

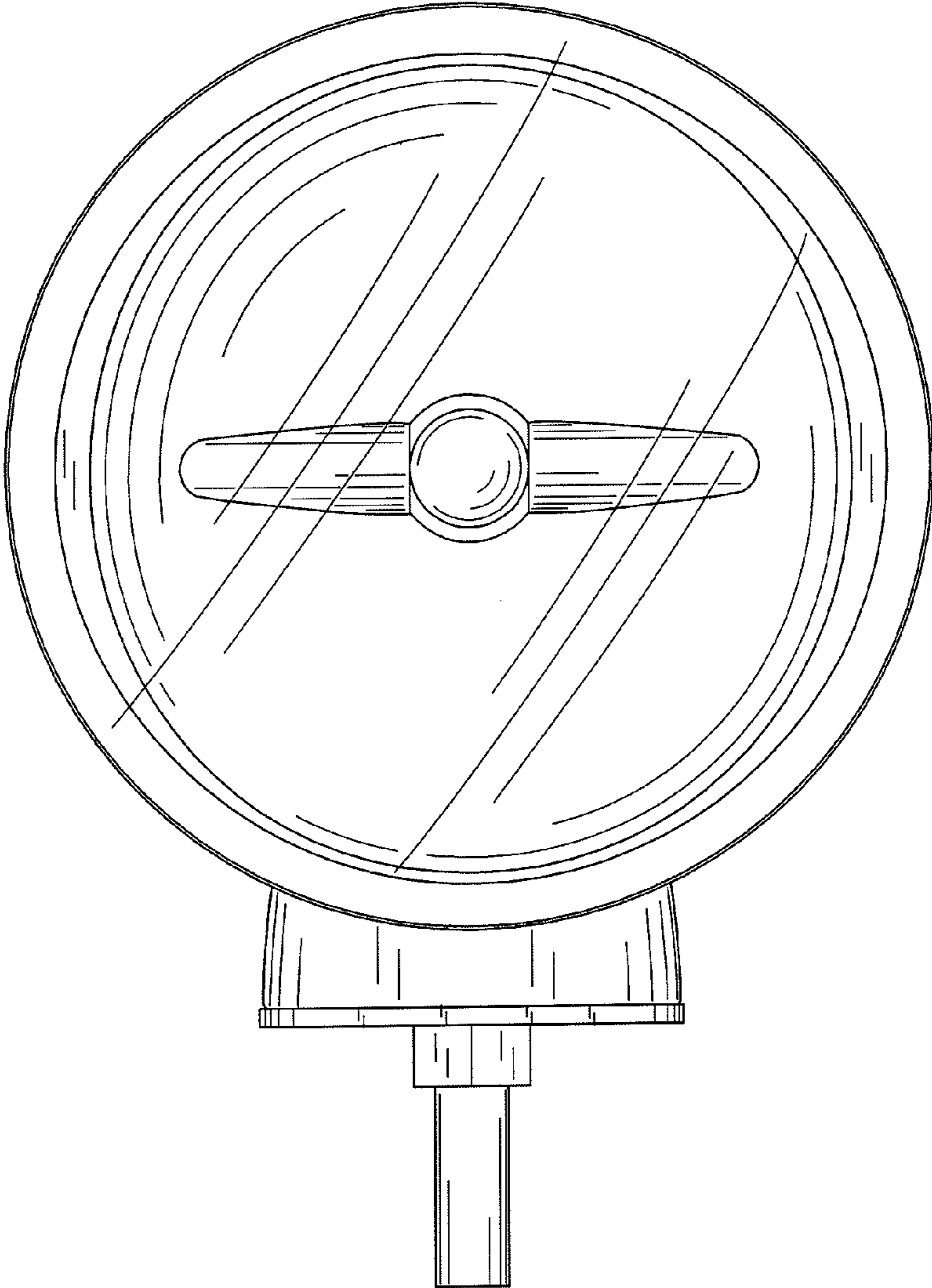

Fig.10

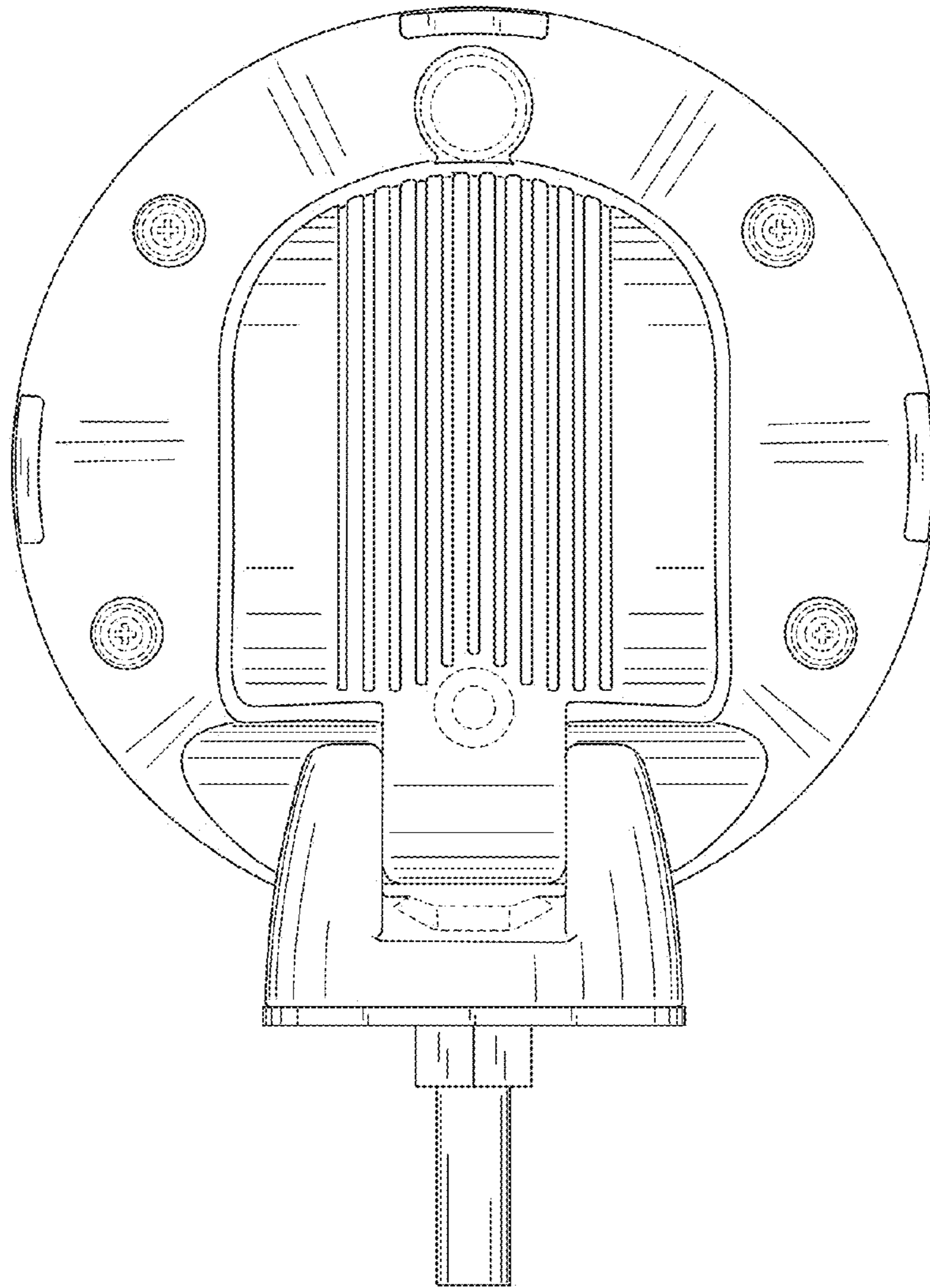

Fig.11

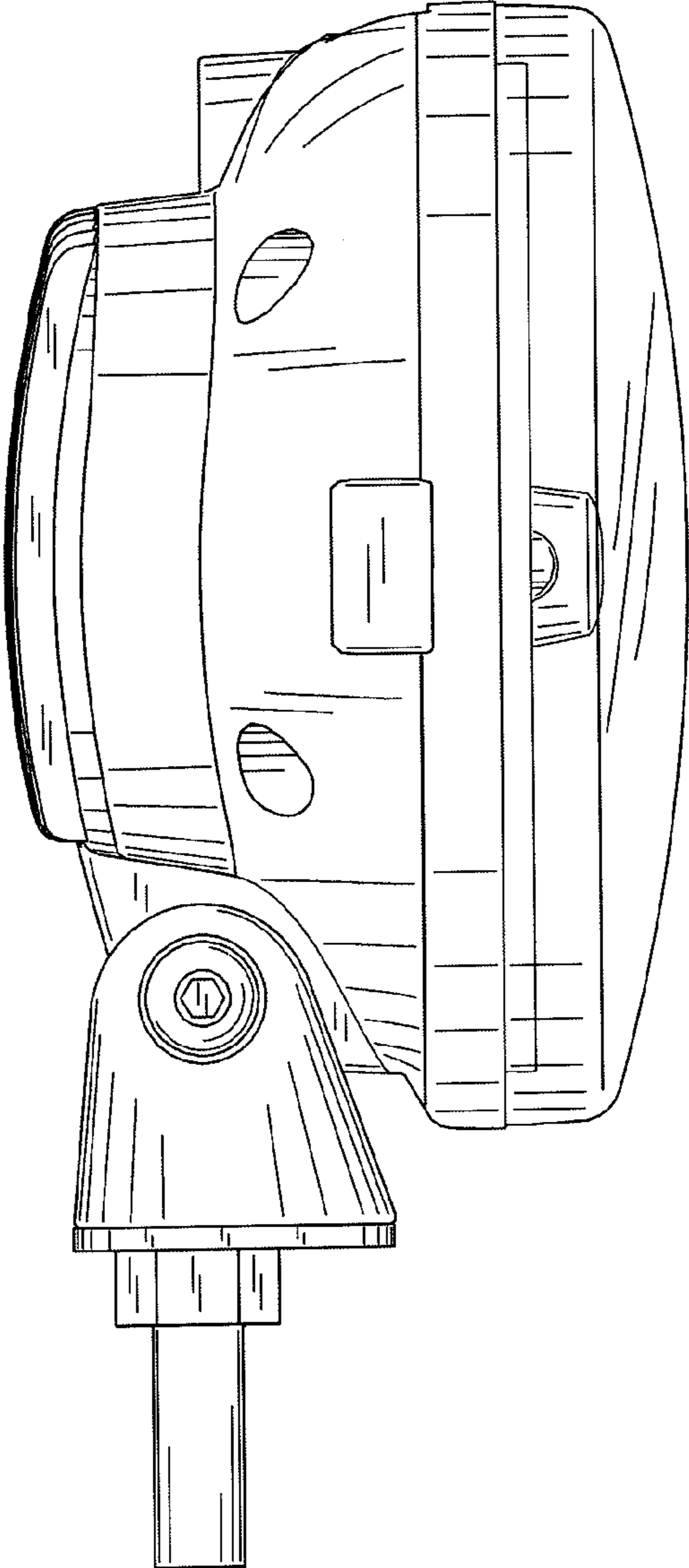

Fig.12

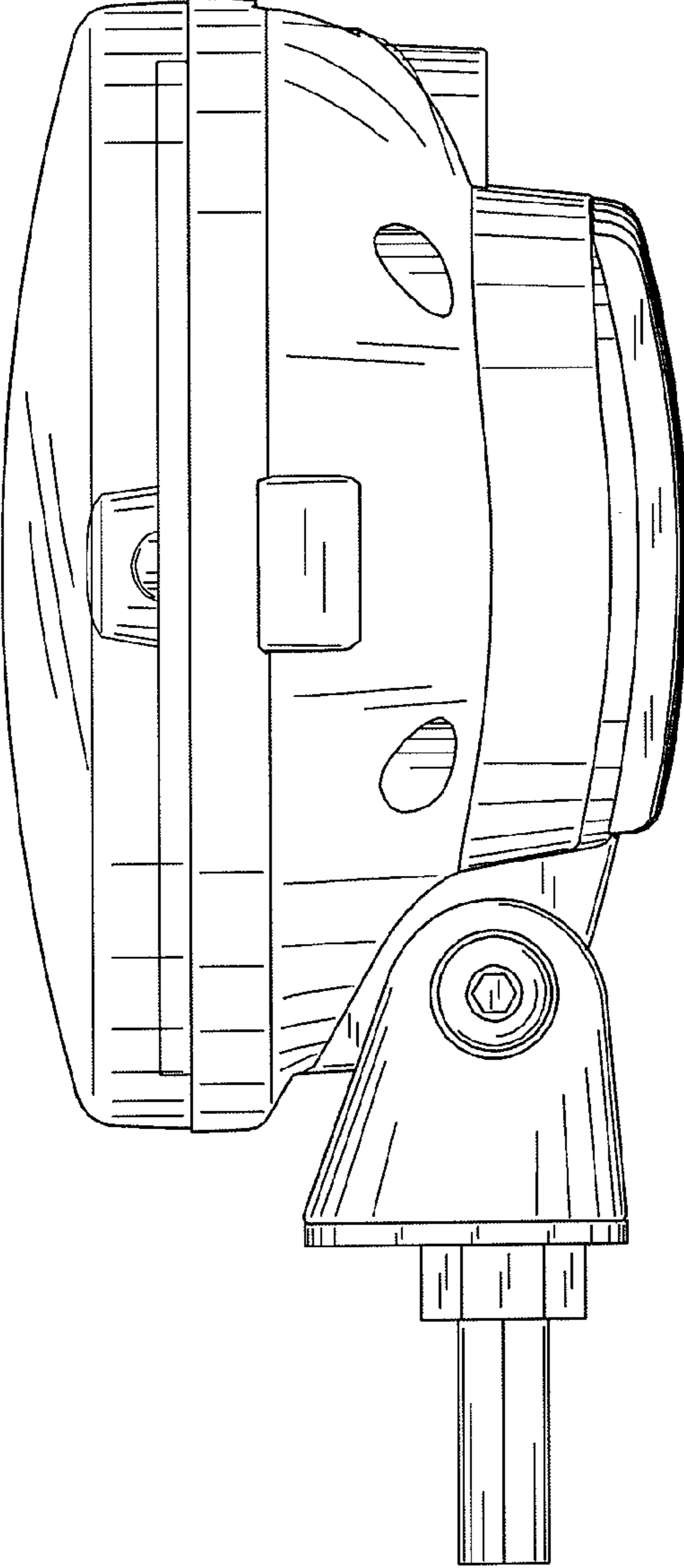

Fig.13

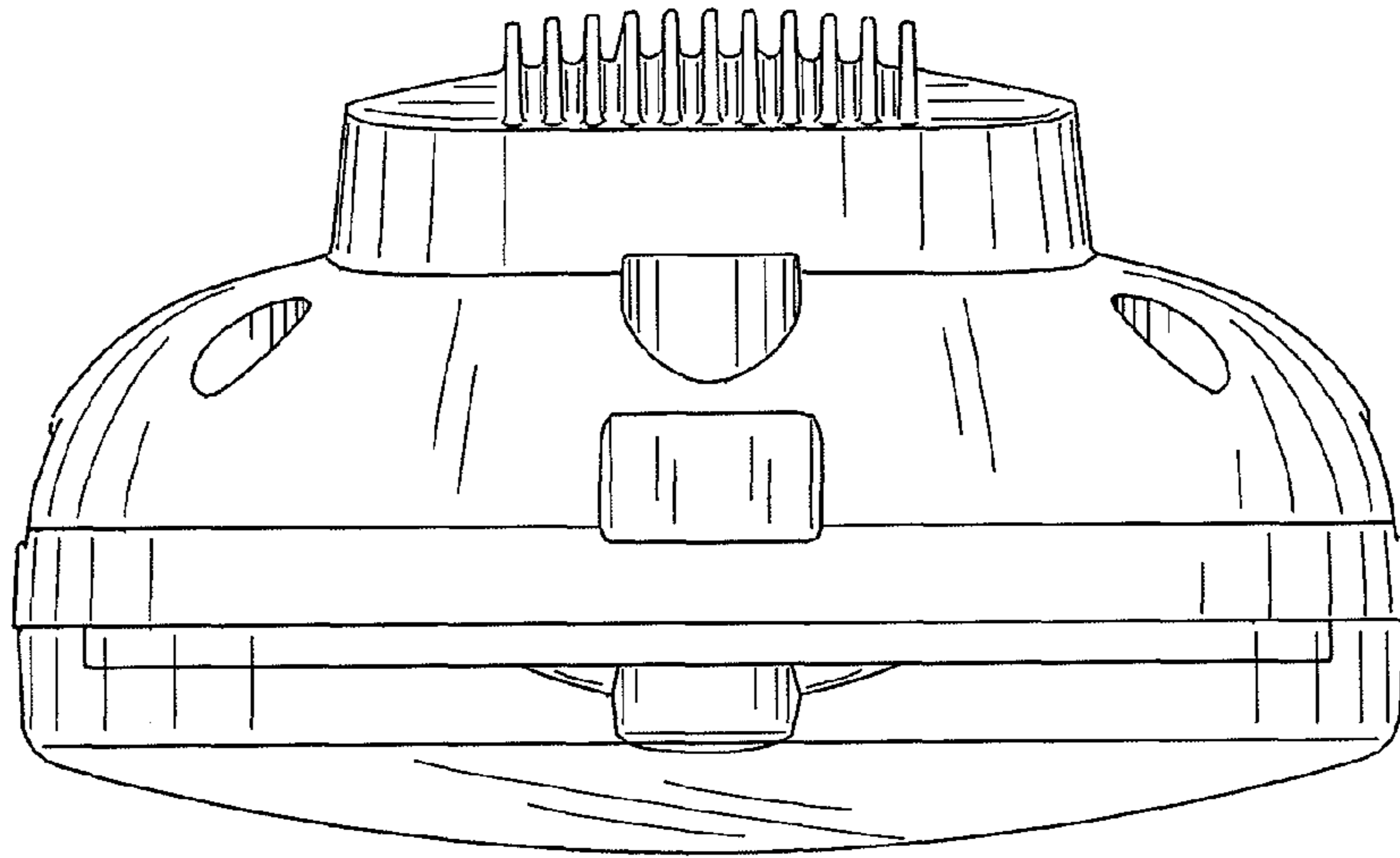

Fig.14

