



US00D739441S

(12) **United States Design Patent**  
**Harkness et al.**

(10) **Patent No.:** **US D739,441 S**  
(45) **Date of Patent:** **\*\* Sep. 22, 2015**

(54) **DUAL NOZZLE PORTABLE AIR COMPRESSOR**

**DESCRIPTION**

(71) Applicants: **Peter J Harkness**, Sterling, IL (US);  
**Keith W Dirks**, Sterlin, IL (US)

(72) Inventors: **Peter J Harkness**, Sterling, IL (US);  
**Keith W Dirks**, Sterlin, IL (US)

(\*\*) Term: **14 Years**

(21) Appl. No.: **29/484,136**

(22) Filed: **Mar. 6, 2014**

(51) **LOC (10) Cl.** ..... **15-02**

(52) **U.S. Cl.**  
USPC ..... **D15/7**

(58) **Field of Classification Search**

USPC ..... D15/7-9; D23/231, 232, 225; 417/60,  
417/235, 265, 321, 355, 358, 363, 359,  
417/410.1, 415-416, 405, 900, 360;  
60/408, 412; 184/26-37; 415/140-147;  
123/495, 509

CPC ..... F04B 25/00; F04B 27/00; F04B 33/00;  
F04B 35/00; F04B 37/00; F04B 39/00;  
F04B 39/12; F04B 41/00; F04B 7/00; F04B  
9/08; F04B 43/00; F04B 43/04; F04B 43/06

See application file for complete search history.

(56) **References Cited**

**U.S. PATENT DOCUMENTS**

D531,194 S *	10/2006	Hertenstein et al. ....	D15/9
D630,229 S *	1/2011	Dreifert .....	D15/7
D668,684 S *	10/2012	Noguchi .....	D15/9
D684,197 S *	6/2013	Kienzle et al. ....	D15/9
D690,324 S *	9/2013	Kienzle et al. ....	D15/9
D698,369 S *	1/2014	Meza et al. ....	D15/7

\* cited by examiner

*Primary Examiner* — Ralf Seifert

(57) **CLAIM**

The ornamental design for a dual nozzle portable air compressor, as shown and described.

FIG. 1 is perspective front view of a dual nozzle portable air compressor with filling nozzles located opposite ends of body, coiled hose for each nozzle, internal power cord storage, pressure gauge, adjustable pressure selection button, with optional attached base and optional attached hanger/handle.

FIG. 2 is perspective back view of a dual nozzle portable air compressor with filling nozzles located opposite ends of body, coiled hose for each nozzle, internal power cord storage, with optional attached base and optional attached hanger/handle.

FIG. 3 is a left elevation view thereof.

FIG. 4 is a back elevation view thereof.

FIG. 5 is a bottom elevation view thereof.

FIG. 6 is a top elevation view thereof.

FIG. 7 is a right elevation view thereof.

FIG. 8 is a front elevation view thereof.

FIG. 9 is perspective front view of a dual nozzle air compressor with filling nozzles located opposite ends of body, coiled hose for each nozzle, internal power cord storage, pressure gauge, adjustable pressure selection button and optional attached hanger/handle and with the optional base removed.

FIG. 10 is perspective back view of FIG. 9 showing a dual nozzle portable air compressor with filling nozzles located opposite ends of body, coiled hose for each nozzle, internal power cord storage, pressure gauge, adjustable pressure selection button and optional hanger/handle and with the optional base removed.

FIG. 11 is a left elevation view of FIG. 9.

FIG. 12 is a back elevation view of FIG. 9.

FIG. 13 is a bottom elevation view of FIG. 9.

FIG. 14 is a top elevation view of FIG. 9.

FIG. 15 is a right elevation view of FIG. 9.

FIG. 16 is a front elevation view of FIG. 9.

FIG. 17 is perspective front view of a dual nozzle air compressor with filling nozzles located opposite ends of body, coiled hose for each nozzle, internal power cord storage, pressure gauge, adjustable pressure selection button and optional attached base and with the optional hanger/handle removed.

FIG. 18 is perspective back view of FIG. 17 showing a dual nozzle portable air compressor with filling nozzles located

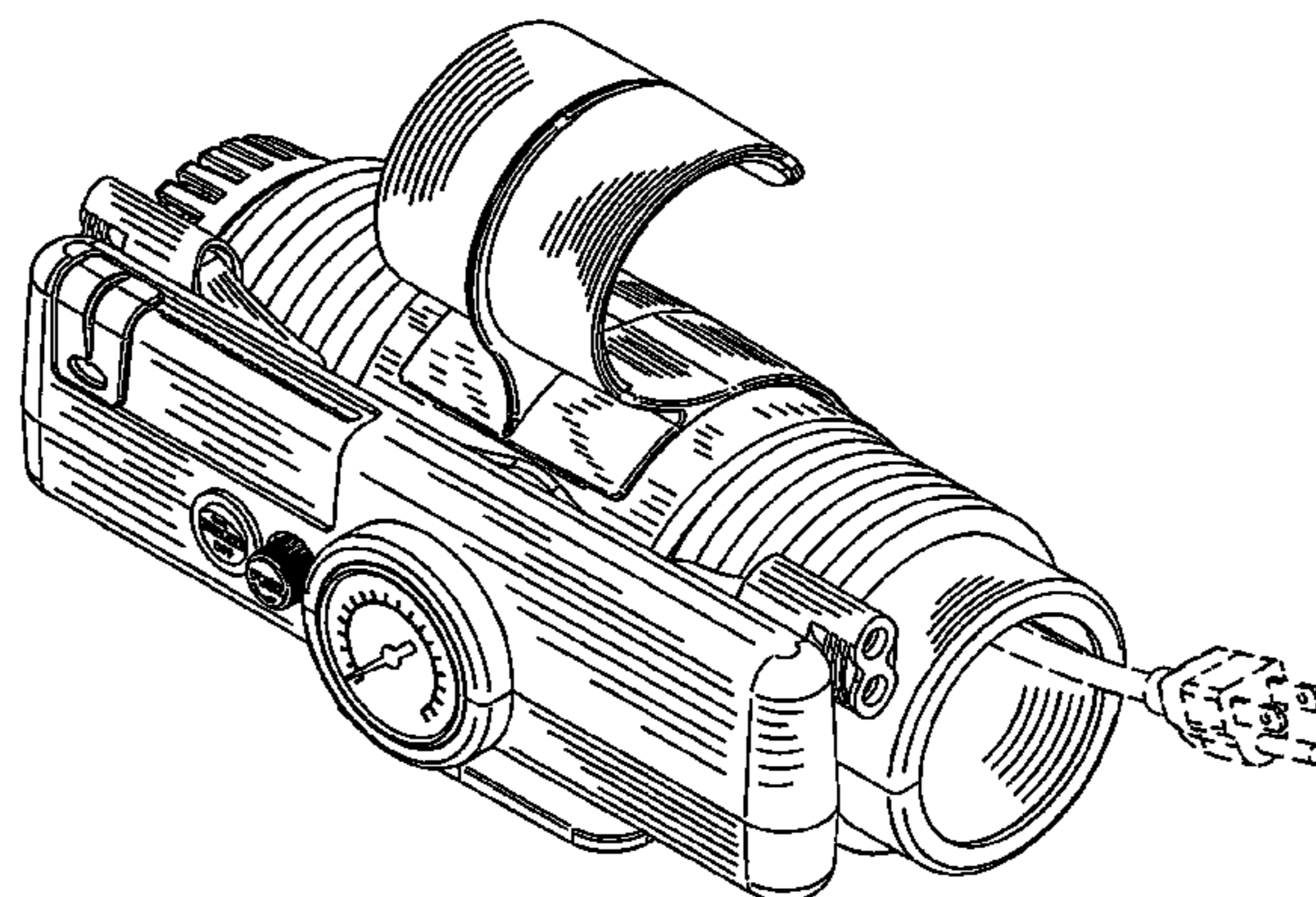

opposite ends of body, coiled hose for each nozzle, internal power cord storage, pressure gauge, adjustable pressure selection button and optional attached base and with the optional hanger/handle removed.

FIG. 19 is a left elevation view of FIG. 17.

FIG. 20 is a back elevation view of FIG. 17.

FIG. 21 is a bottom elevation view of FIG. 17.

FIG. 22 is a top elevation view of FIG. 17.

FIG. 23 is a right elevation view of FIG. 17.

FIG. 24 is a front elevation view of FIG. 17.

FIG. 25 is perspective front view of a dual nozzle portable air compressor with filling nozzles located opposite ends of body, coiled hose for each nozzle, internal power cord storage, pressure gauge, adjustable pressure selection button with the optional base and hanger/handle removed.

FIG. 26 is perspective back view of FIG. 25 showing a dual nozzle portable air compressor with filling nozzles located opposite ends of body, coiled hose for each nozzle, internal power cord storage, pressure gauge, adjustable pressure selection button with the optional base and hanger/handle removed.

FIG. 27 is a left elevation view of FIG. 25.

FIG. 28 is a back elevation view of FIG. 25.

FIG. 29 is a bottom elevation view of FIG. 25.

FIG. 30 is a top elevation view of FIG. 25.

FIG. 31 is a right elevation view of FIG. 25.

FIG. 32 is a front elevation view of FIG. 25.

FIG. 33 is a detail, perspective front view of hanger/handle which is shown detached for the ease of illustration.

FIG. 34 is perspective back view of FIG. 33.

FIG. 35 is a top elevation view of FIG. 33.

FIG. 36 is a front elevation view of FIG. 33.

FIG. 37 is a right side elevation view of FIG. 33.

FIG. 38 is a back elevation view of FIG. 33.

FIG. 39 is a bottom elevation view of FIG. 33.

FIG. 40 is a detail, perspective front view of base, which is shown detached for ease of illustration.

FIG. 41 is perspective back view of FIG. 40.

FIG. 42 is a top elevation view of FIG. 40.

FIG. 43 is a front elevation view of FIG. 40.

FIG. 44 is a right side elevation view of FIG. 40.

FIG. 45 is a back elevation view of FIG. 40; and,

FIG. 46 is a bottom elevation view of FIG. 40.

**1 Claim, 14 Drawing Sheets**

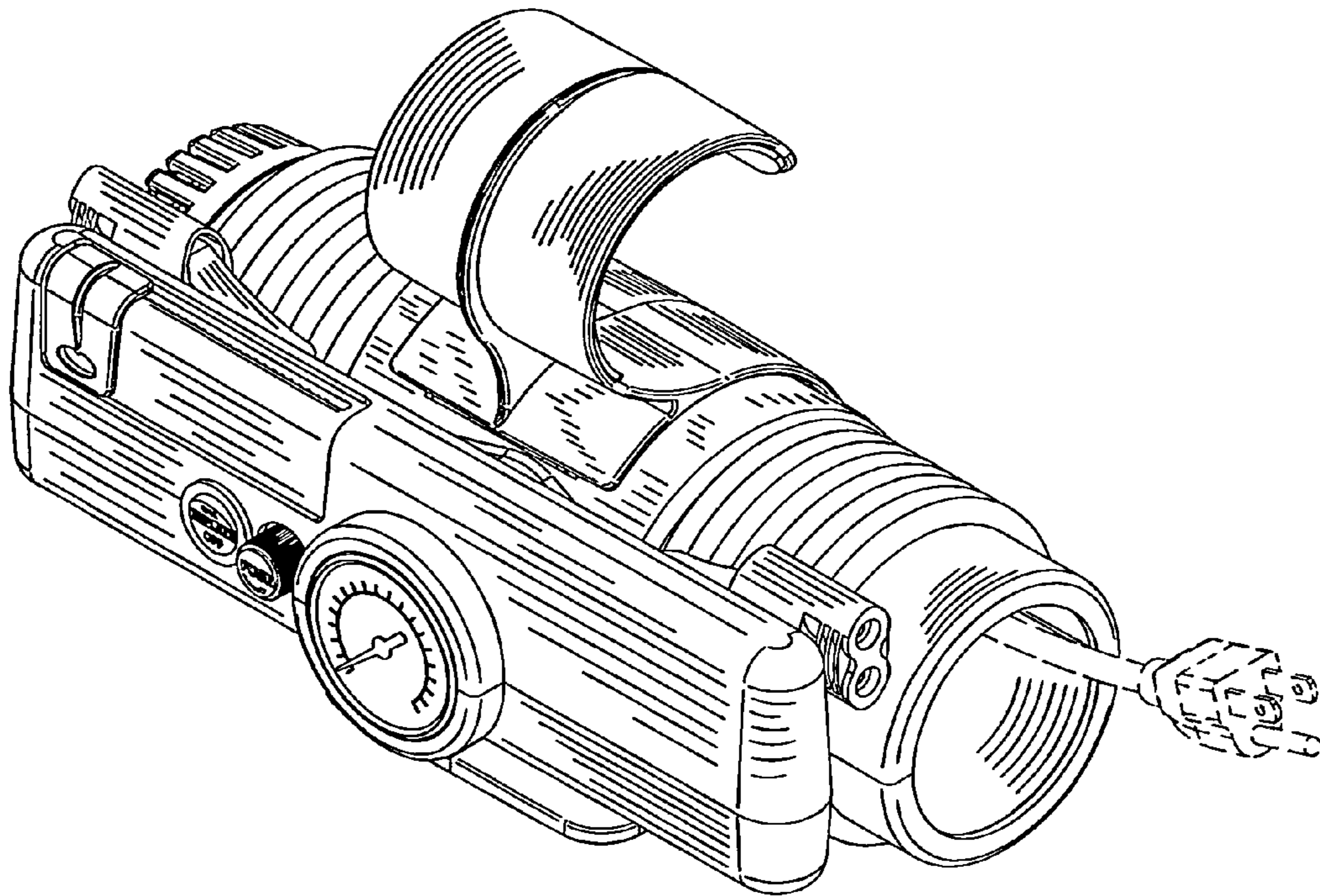

FIG. 1

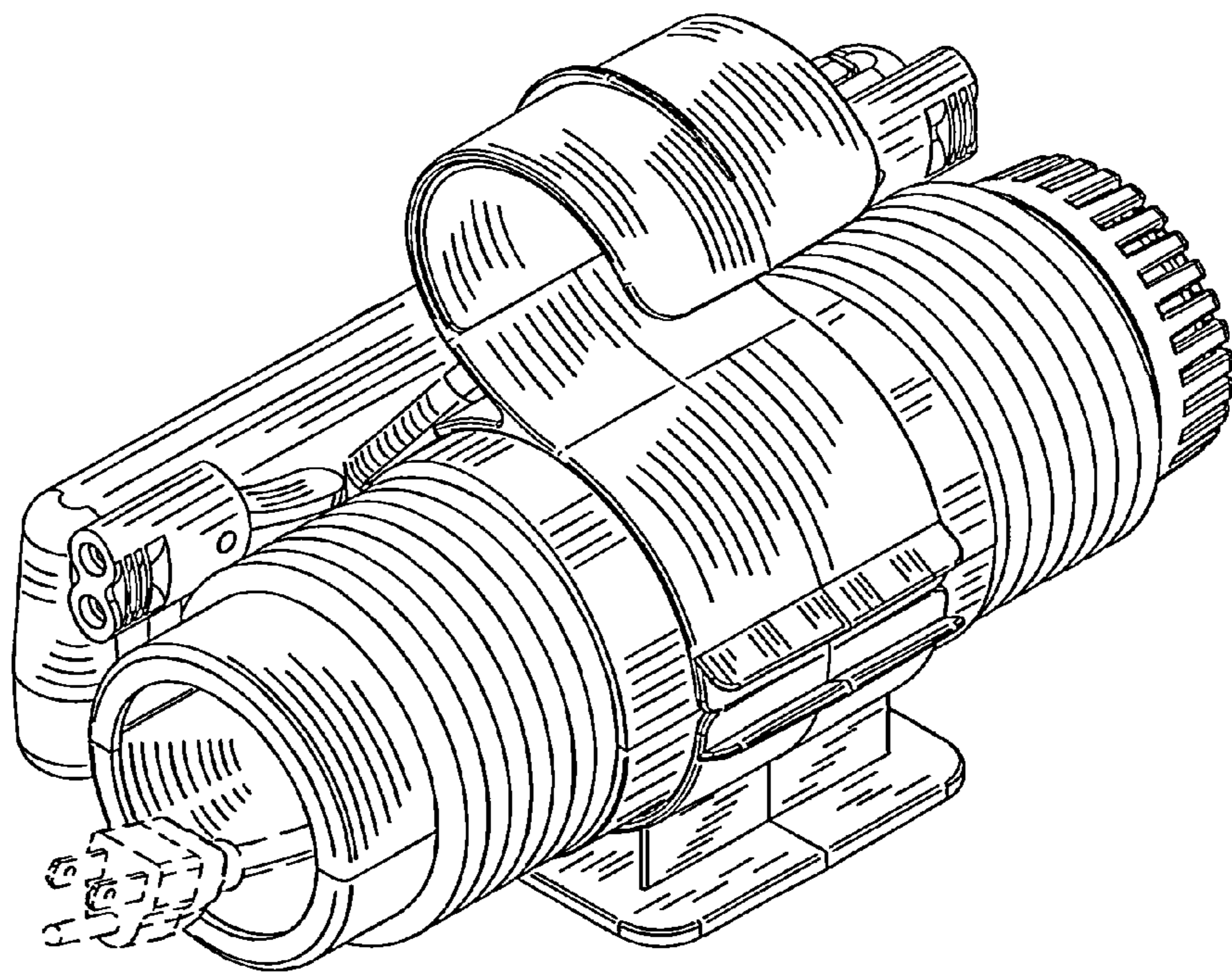

FIG. 2

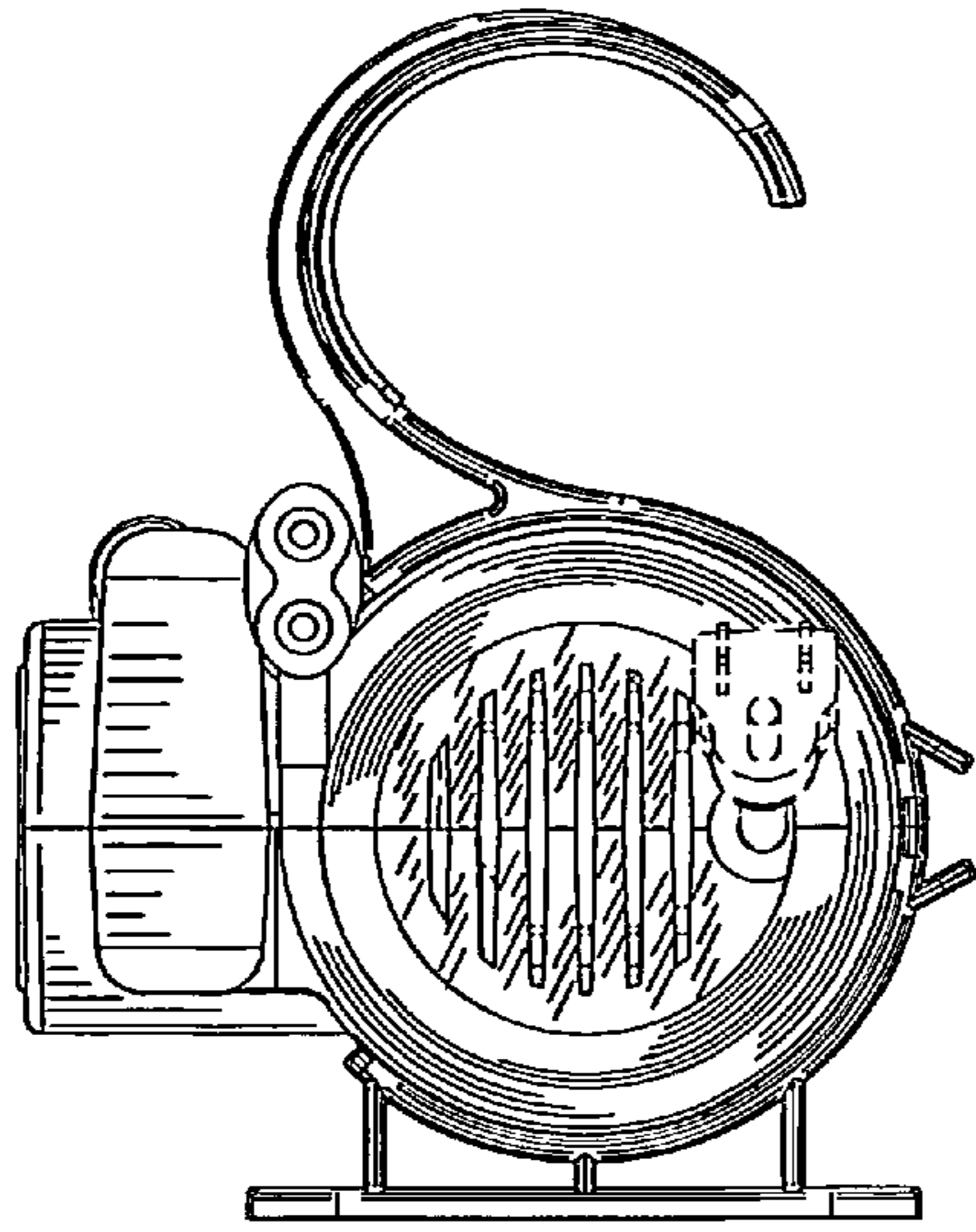

FIG. 3

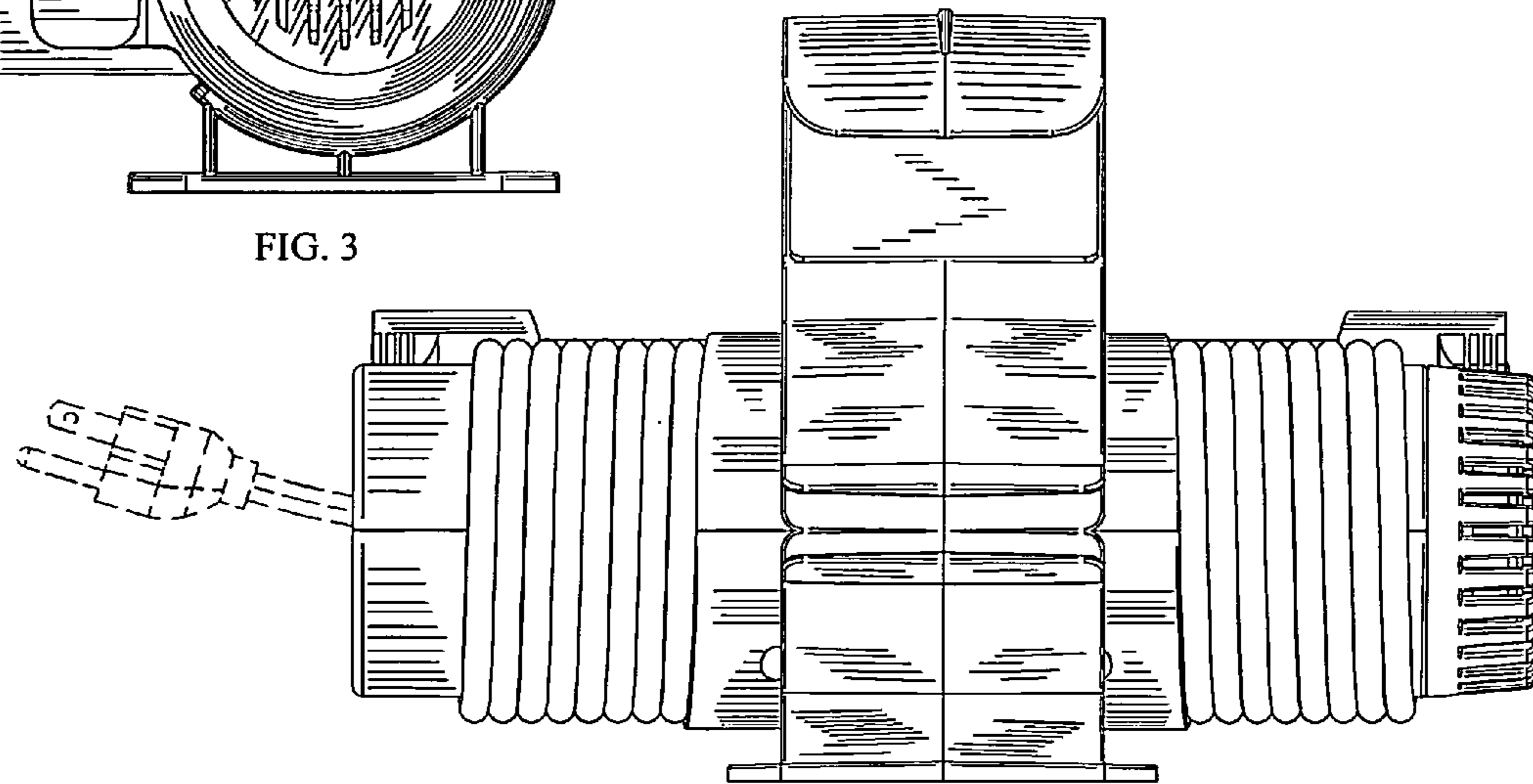

FIG. 4

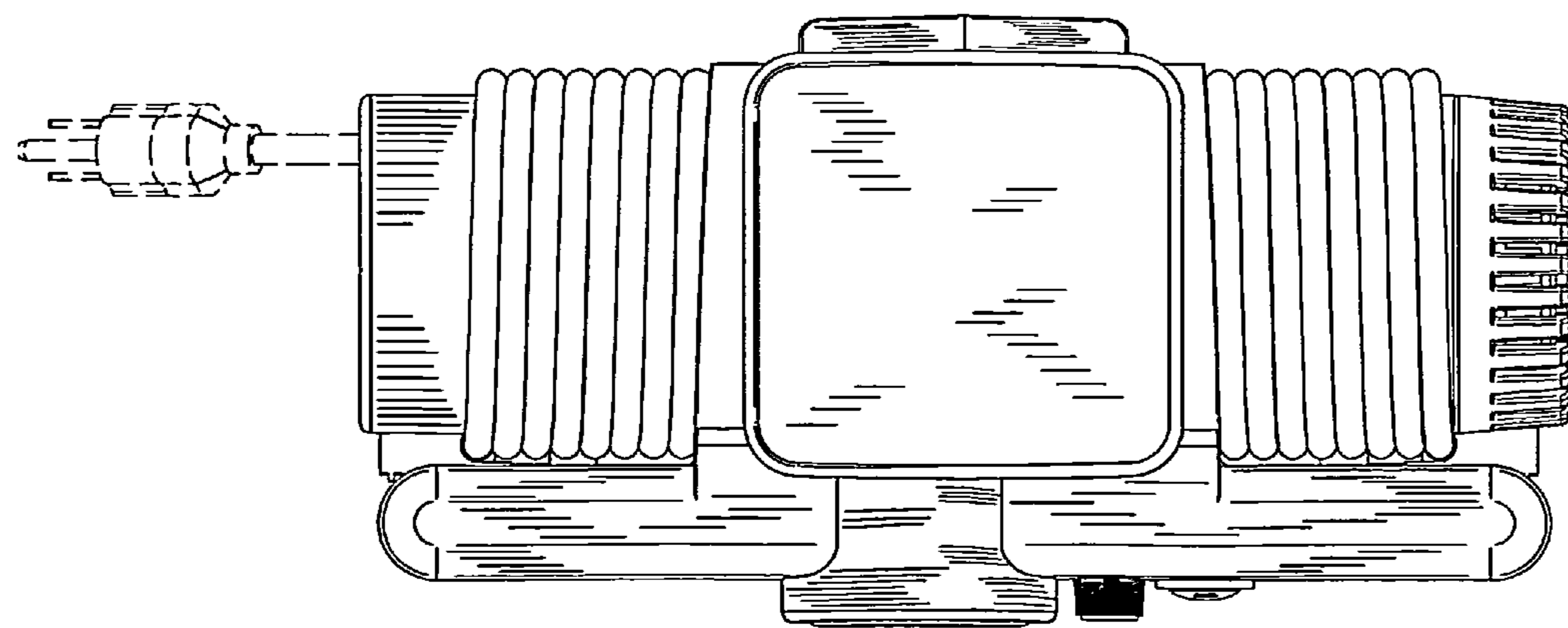

FIG. 5

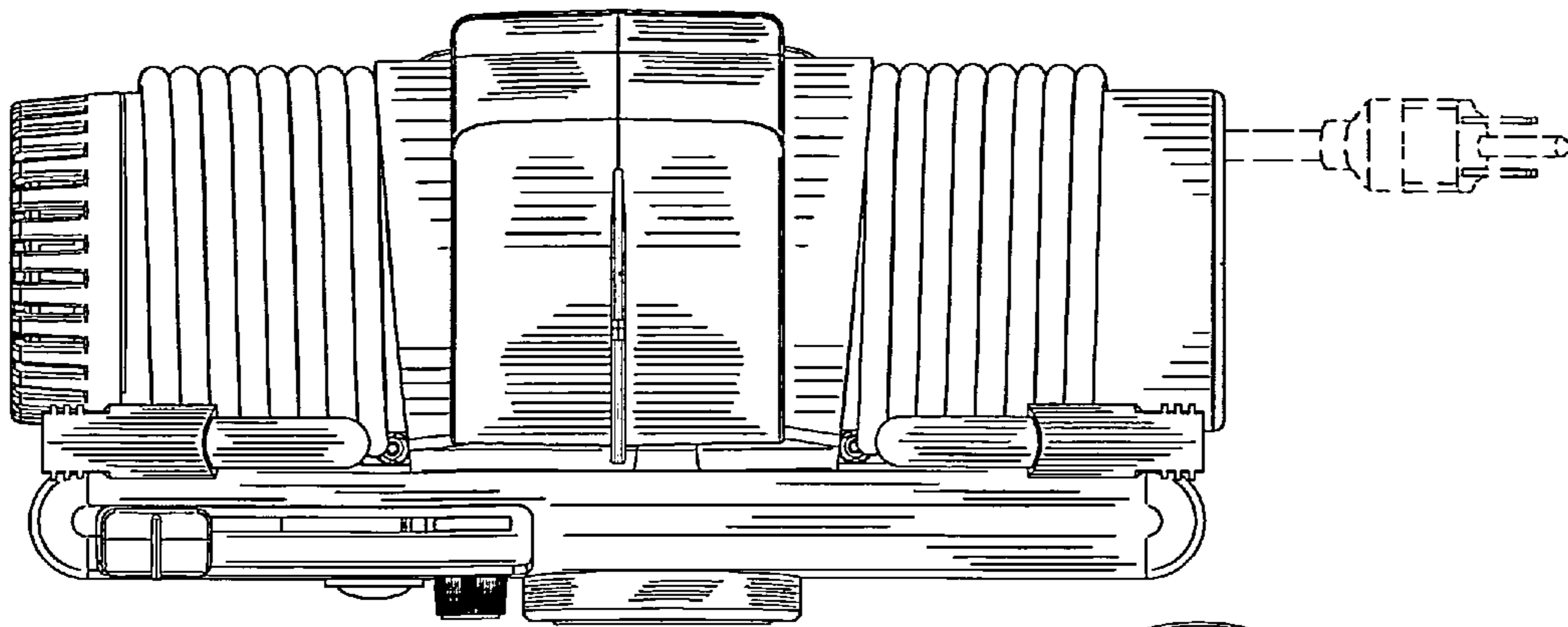

FIG. 6

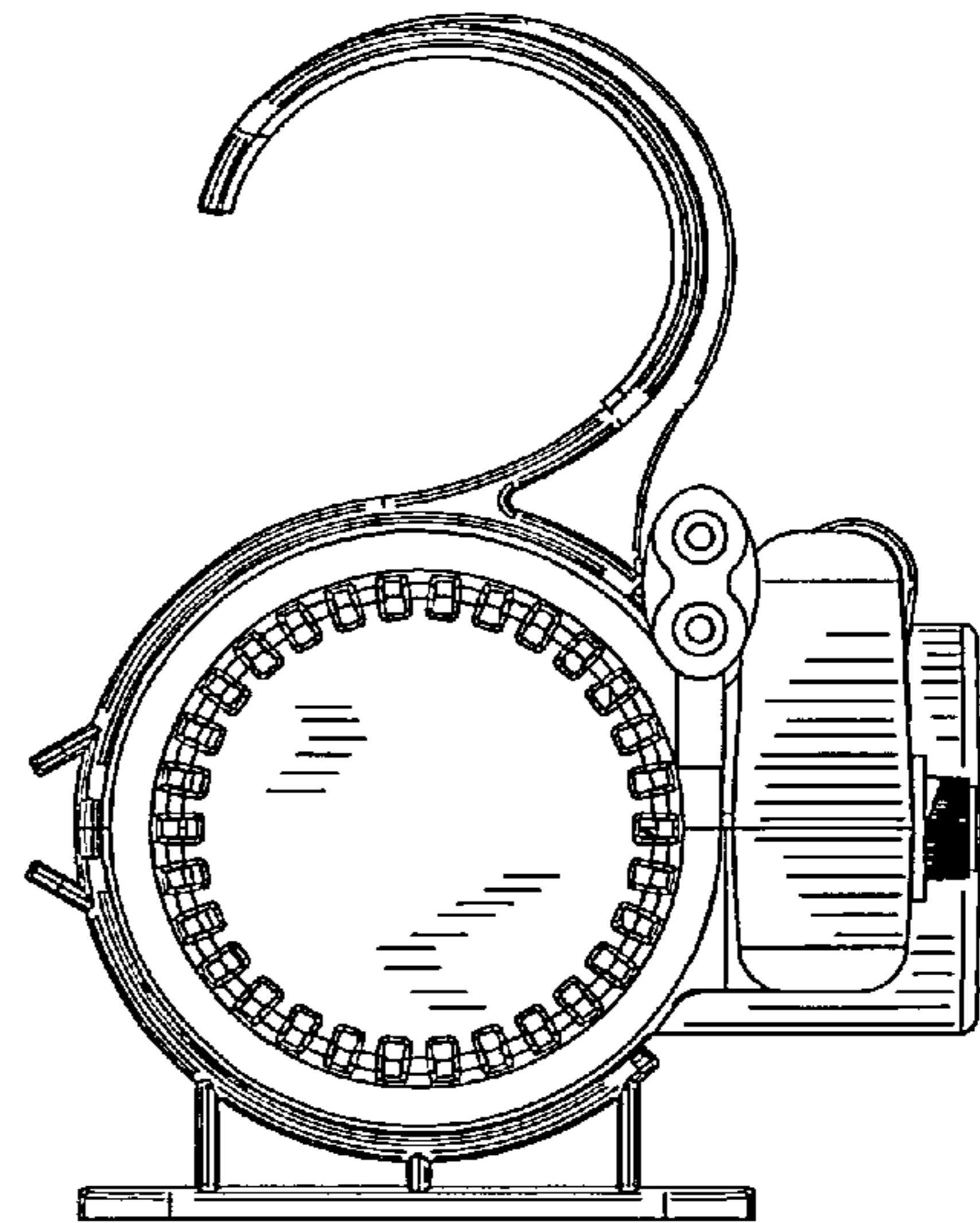

FIG. 7

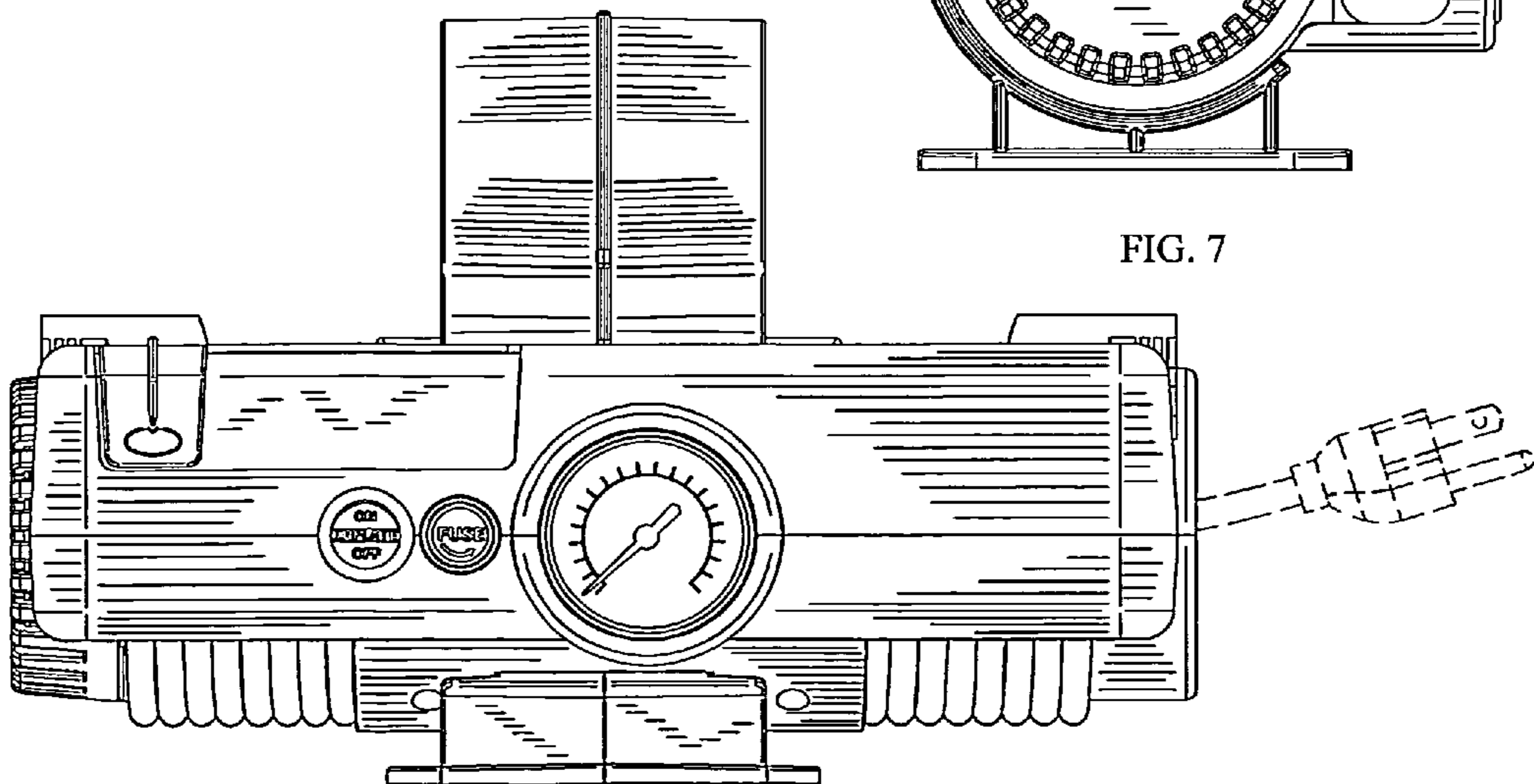

FIG. 8

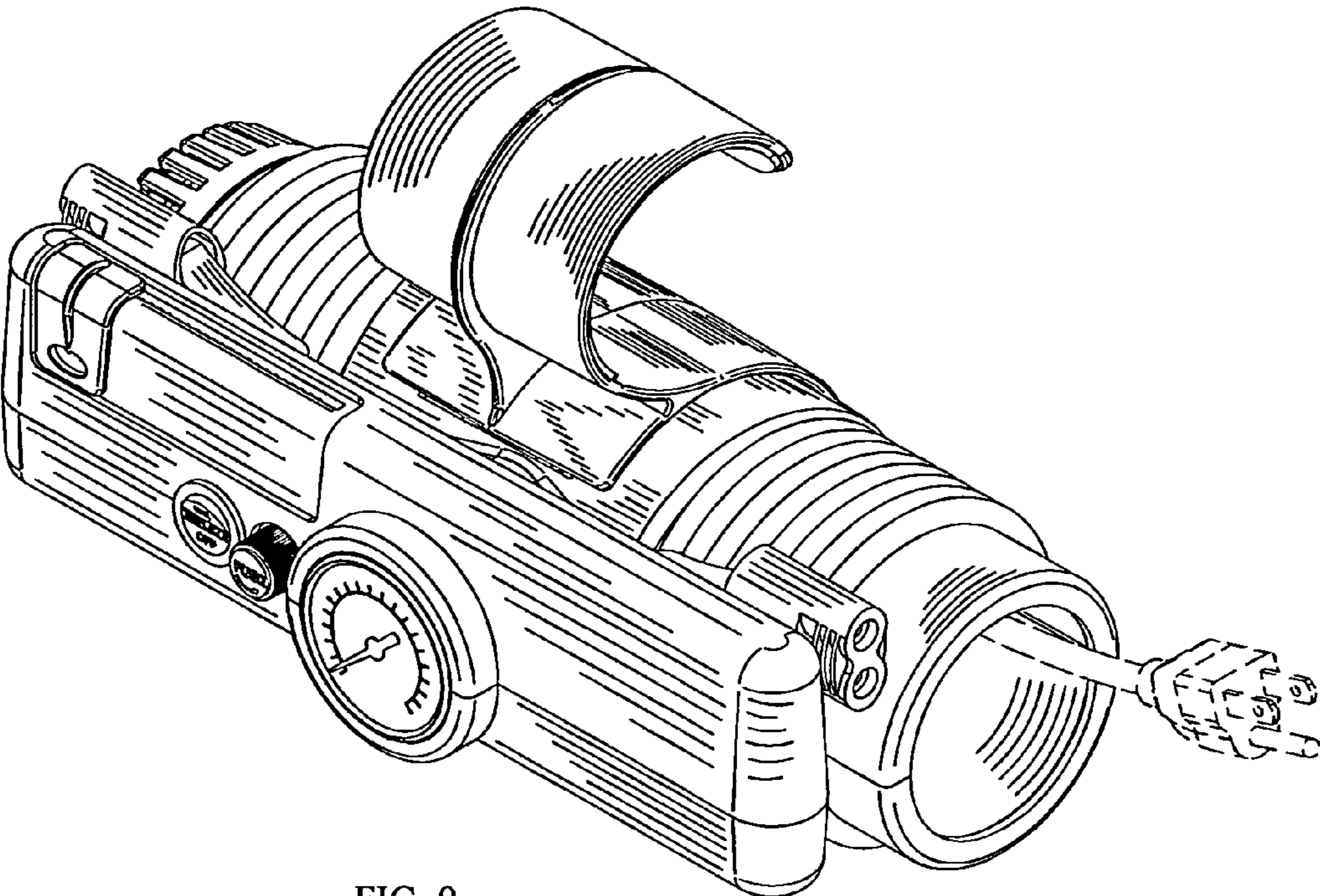

FIG. 9

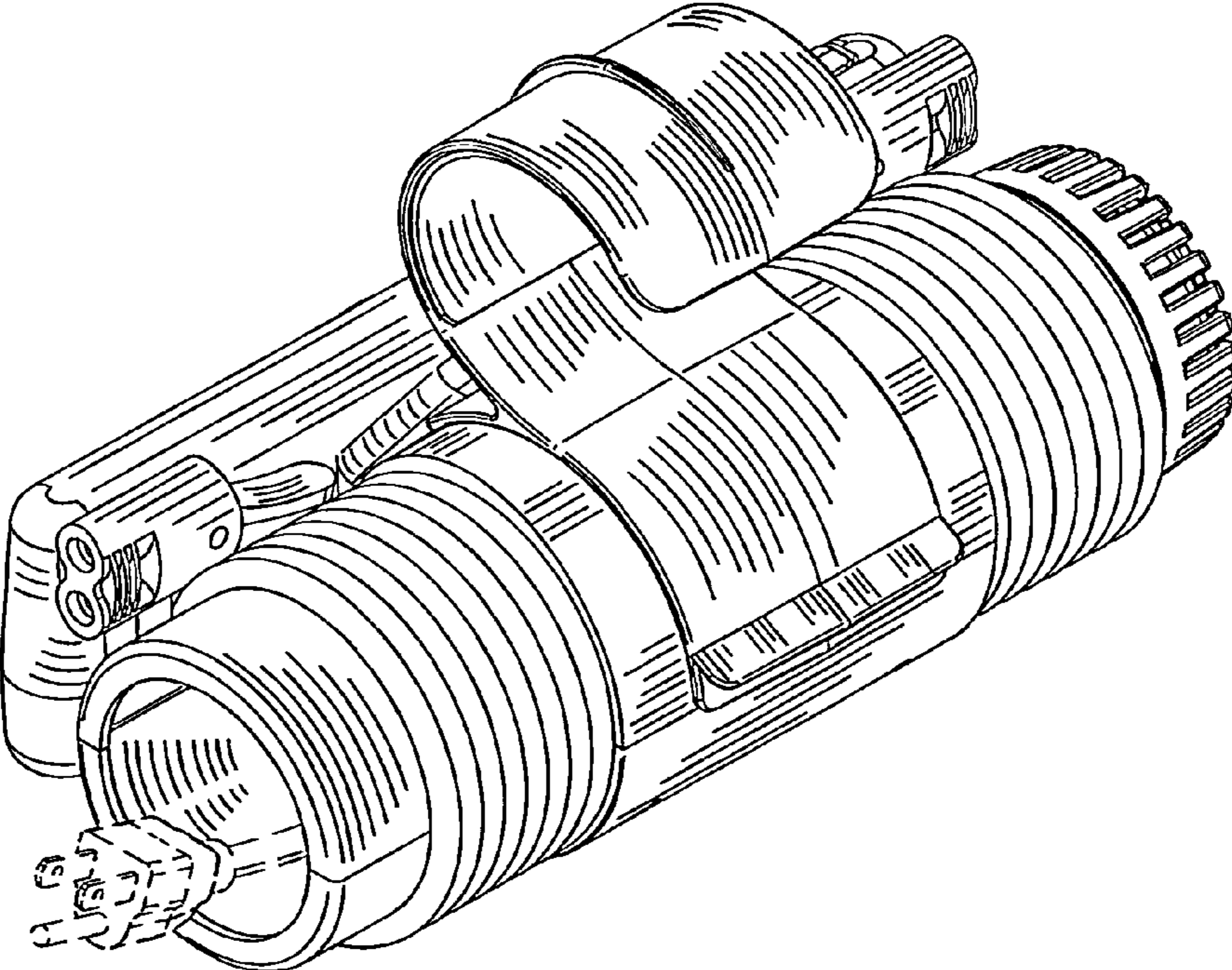

FIG. 10

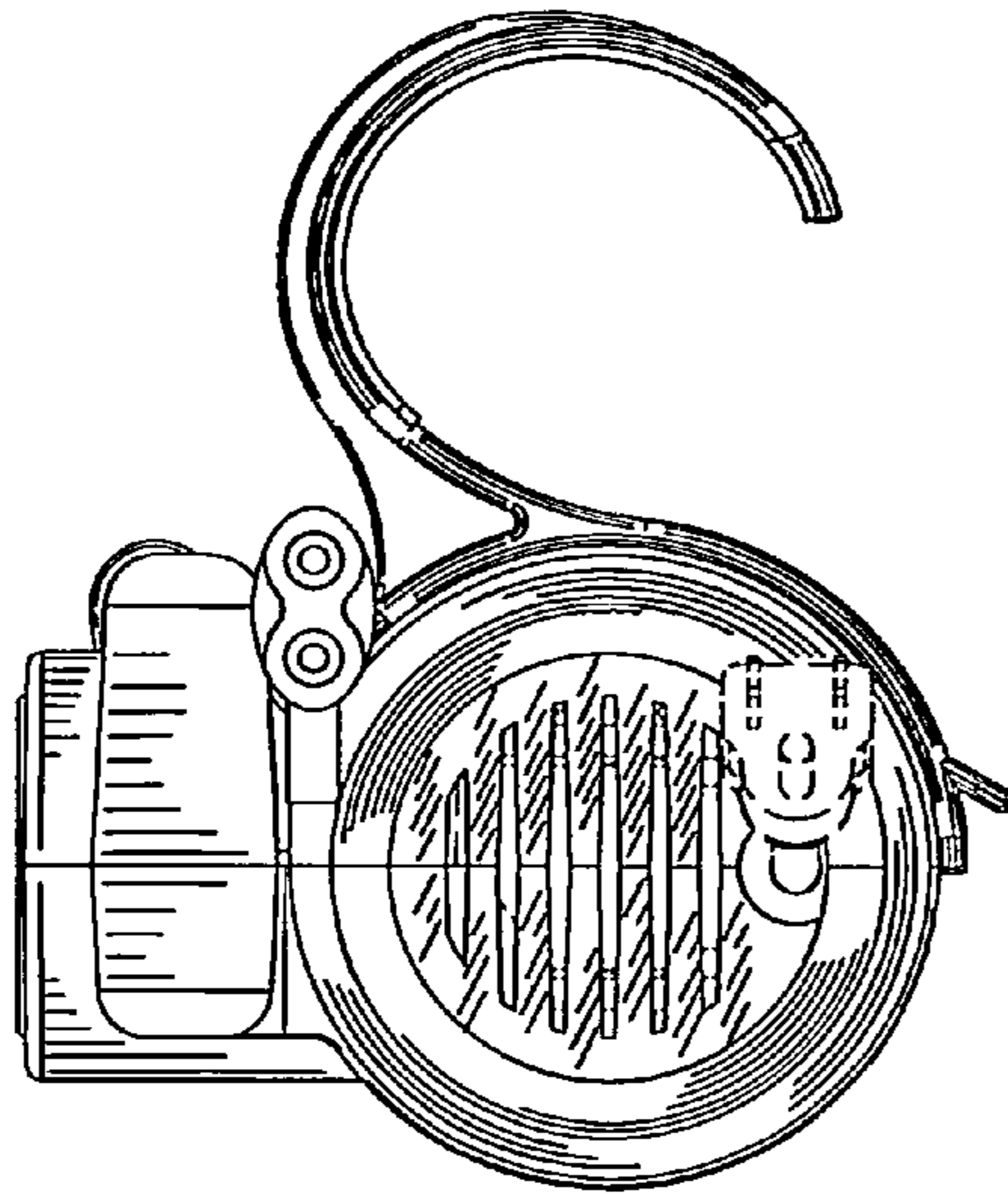

FIG. 11

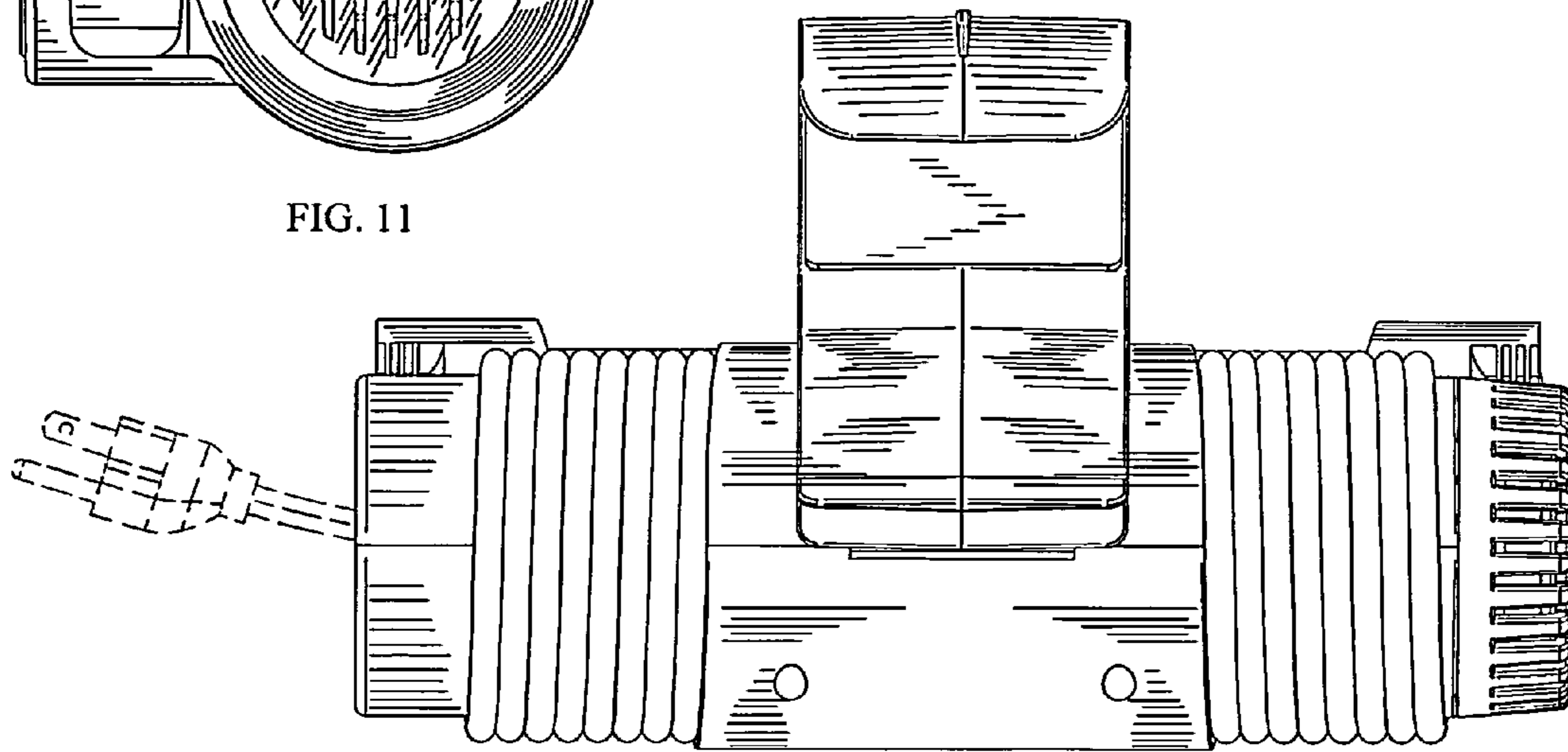

FIG. 12

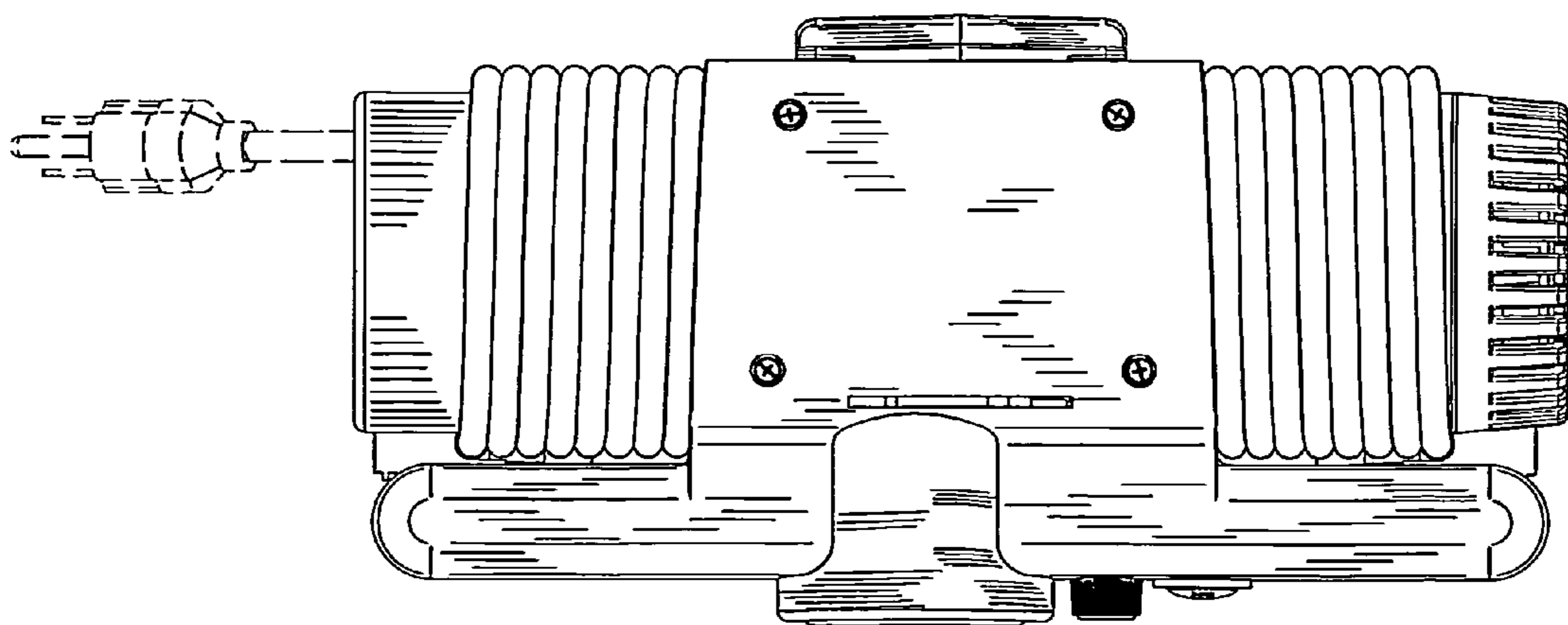

FIG. 13



FIG. 14

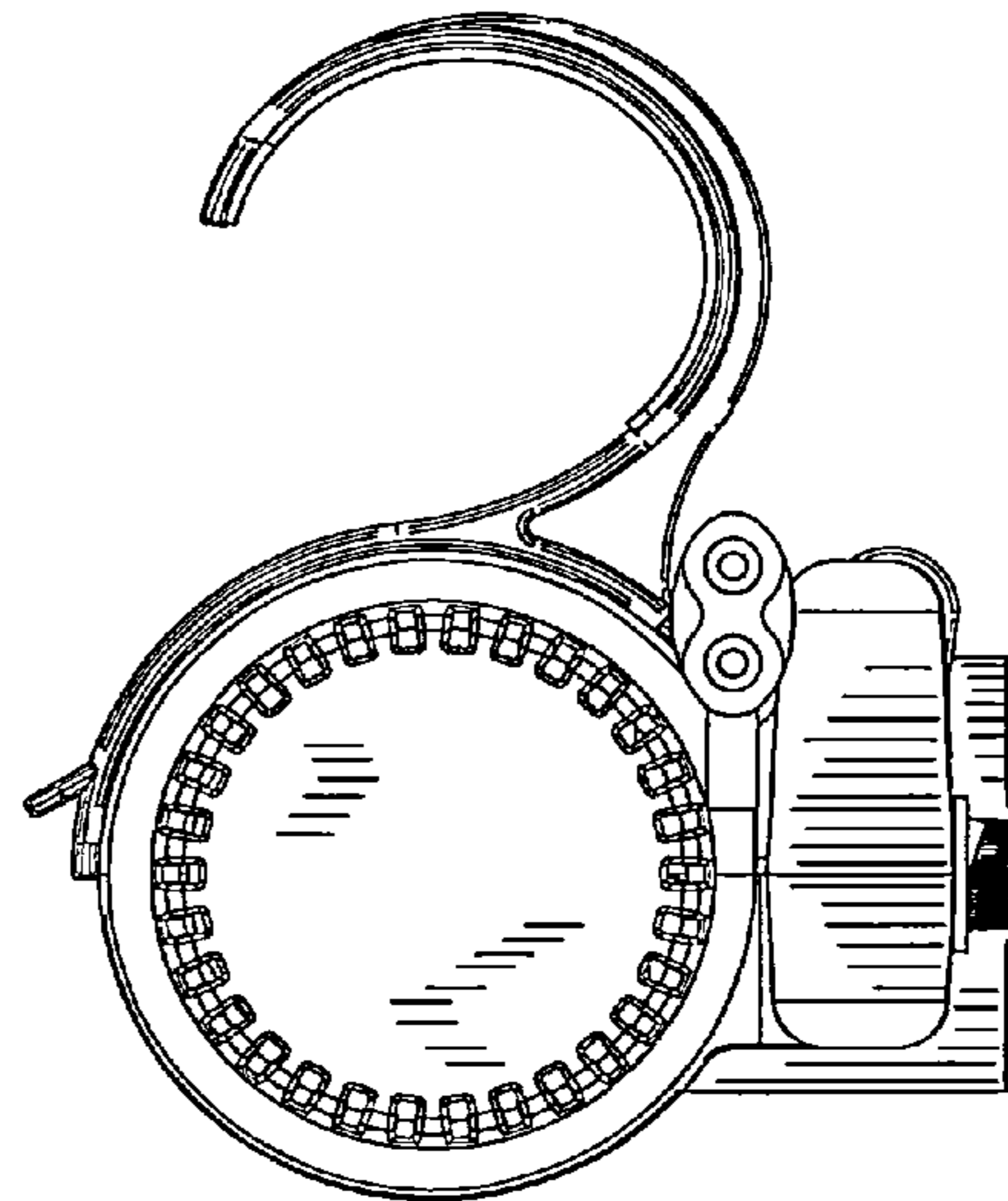

FIG. 15

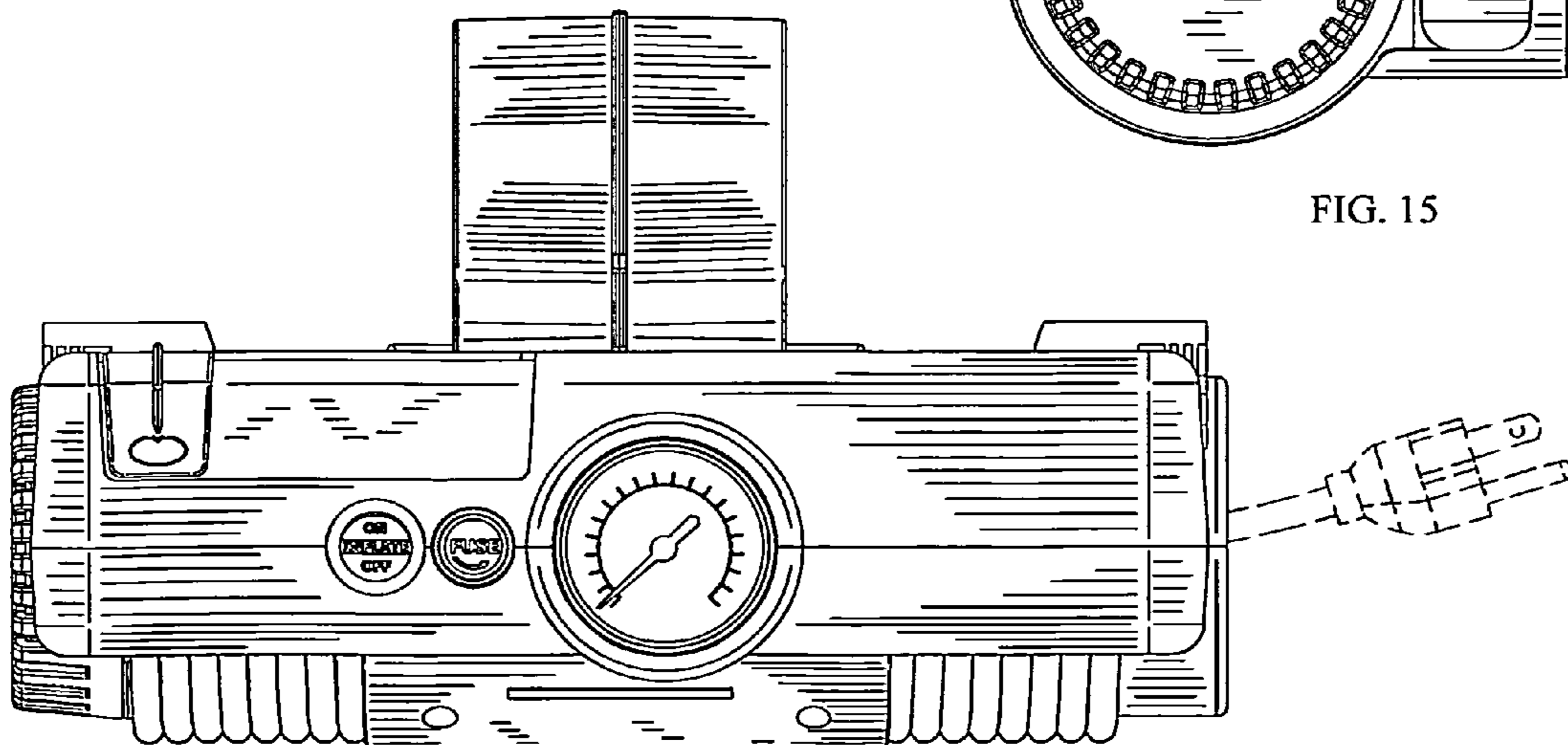

FIG. 16



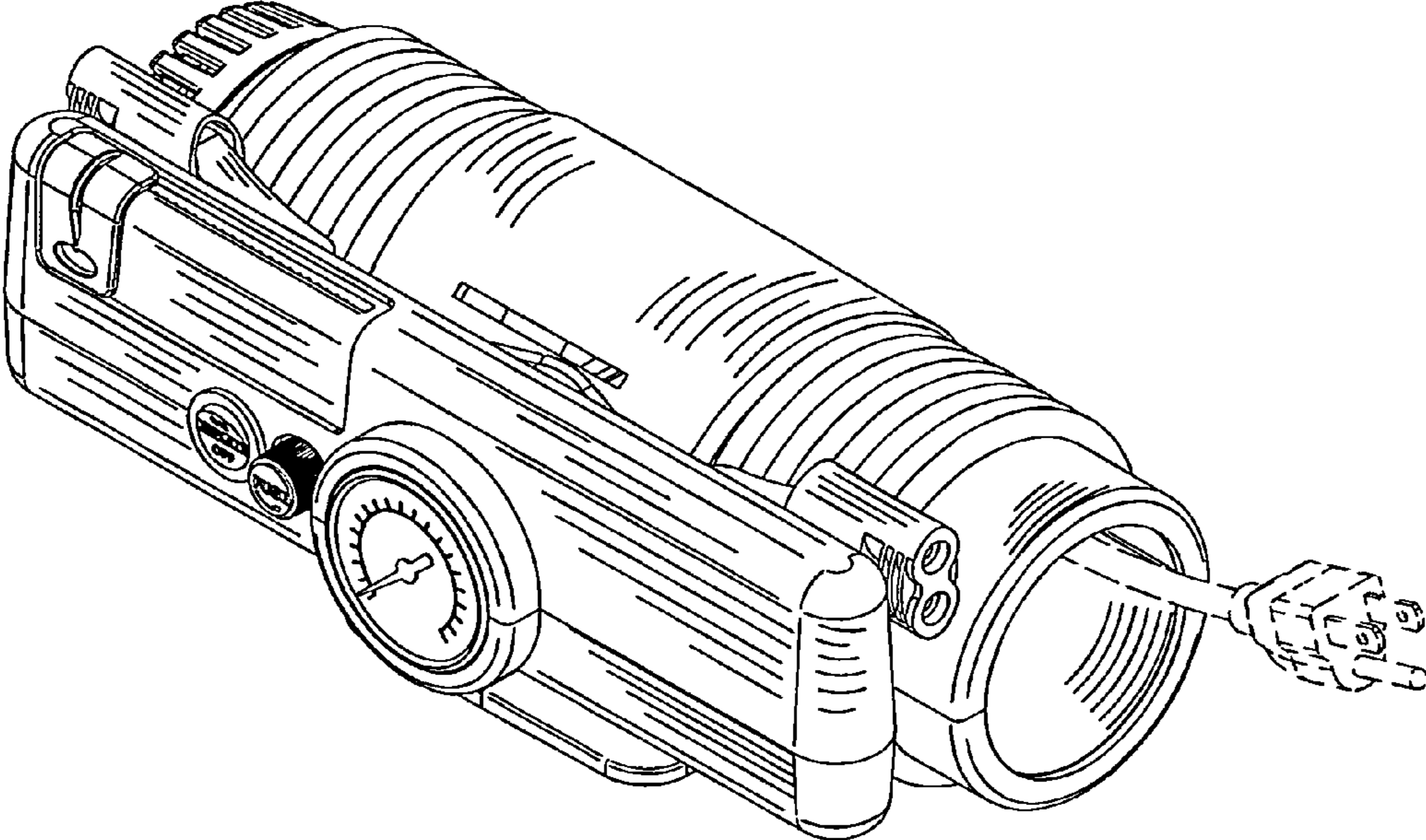

FIG. 17

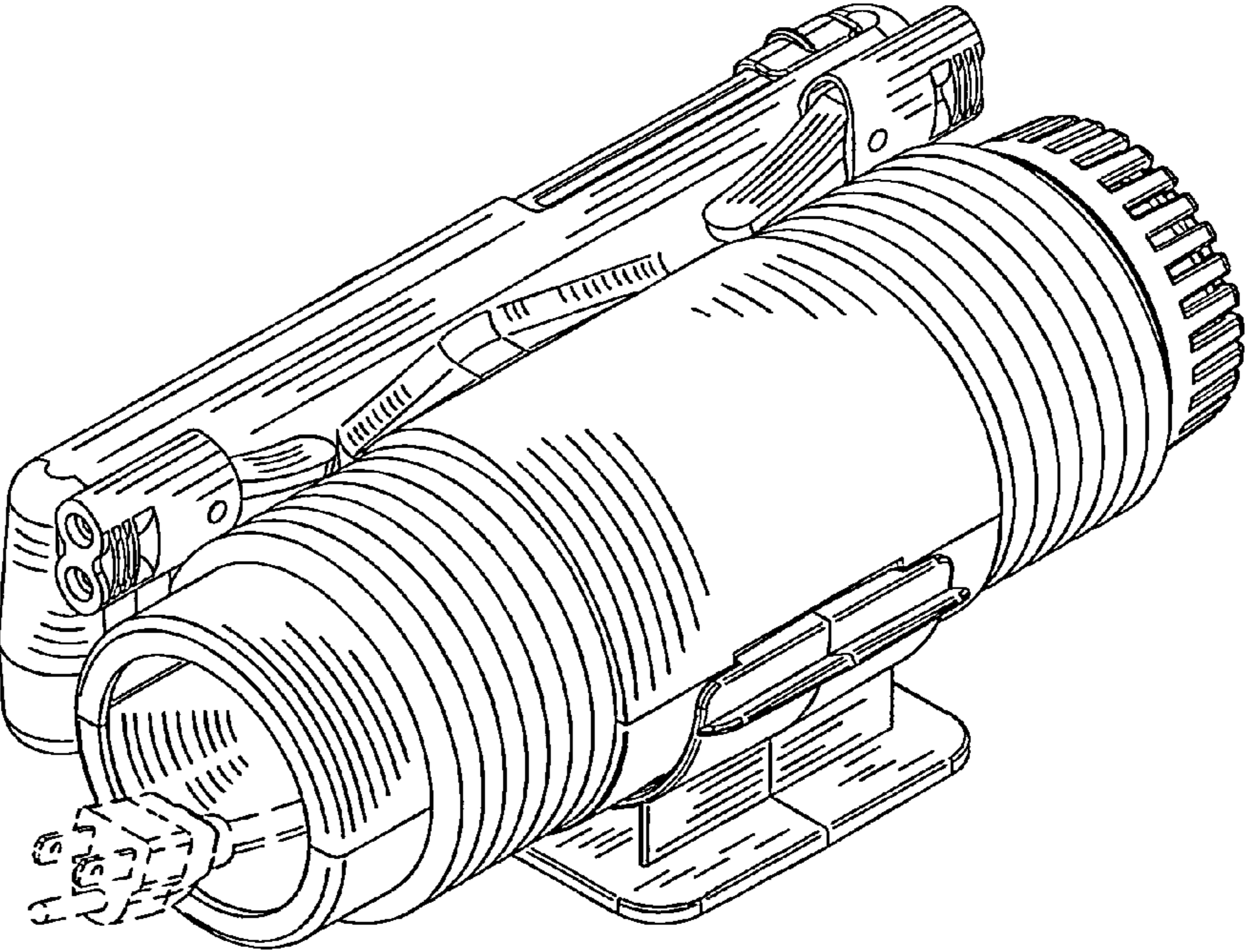

FIG. 18

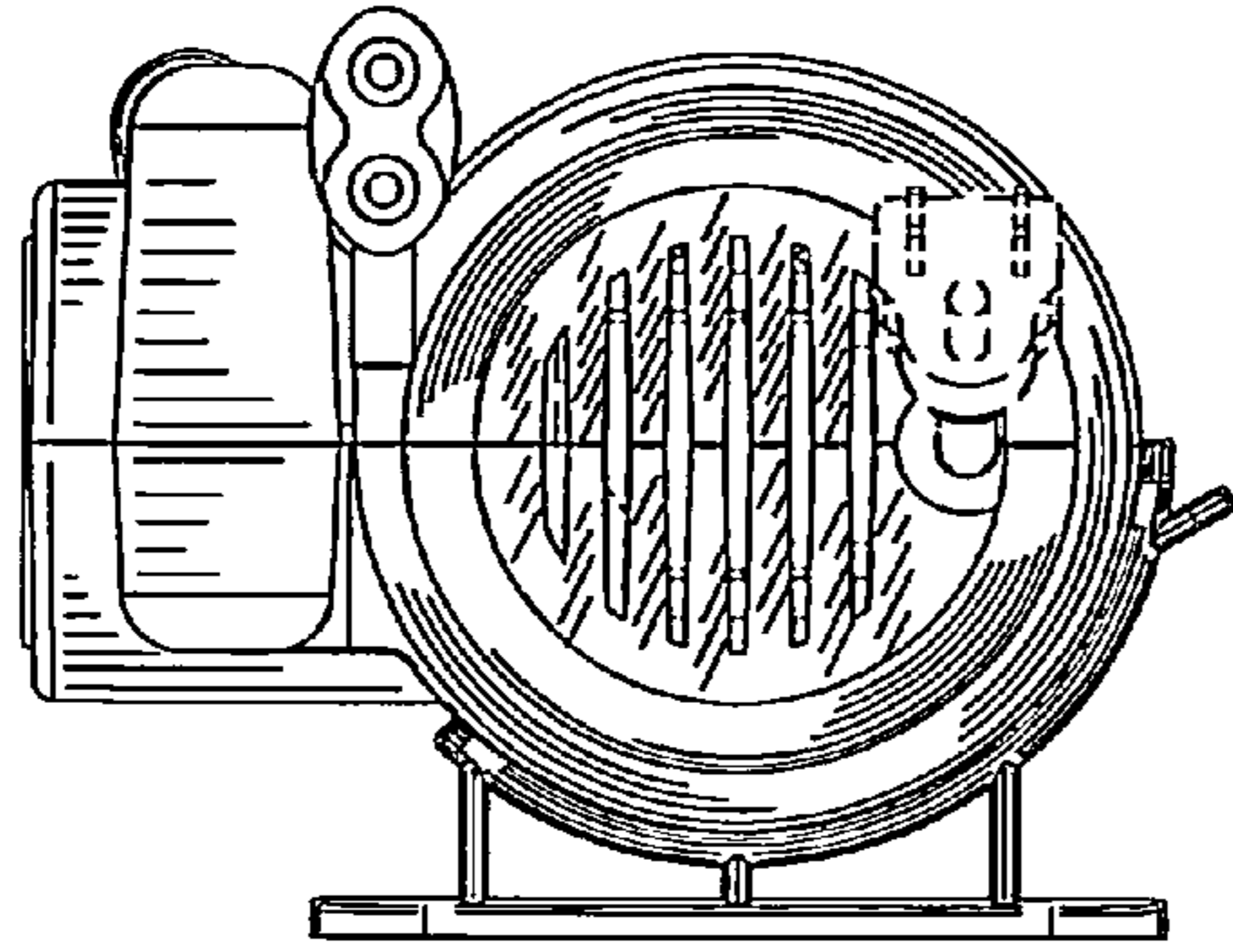

FIG. 19

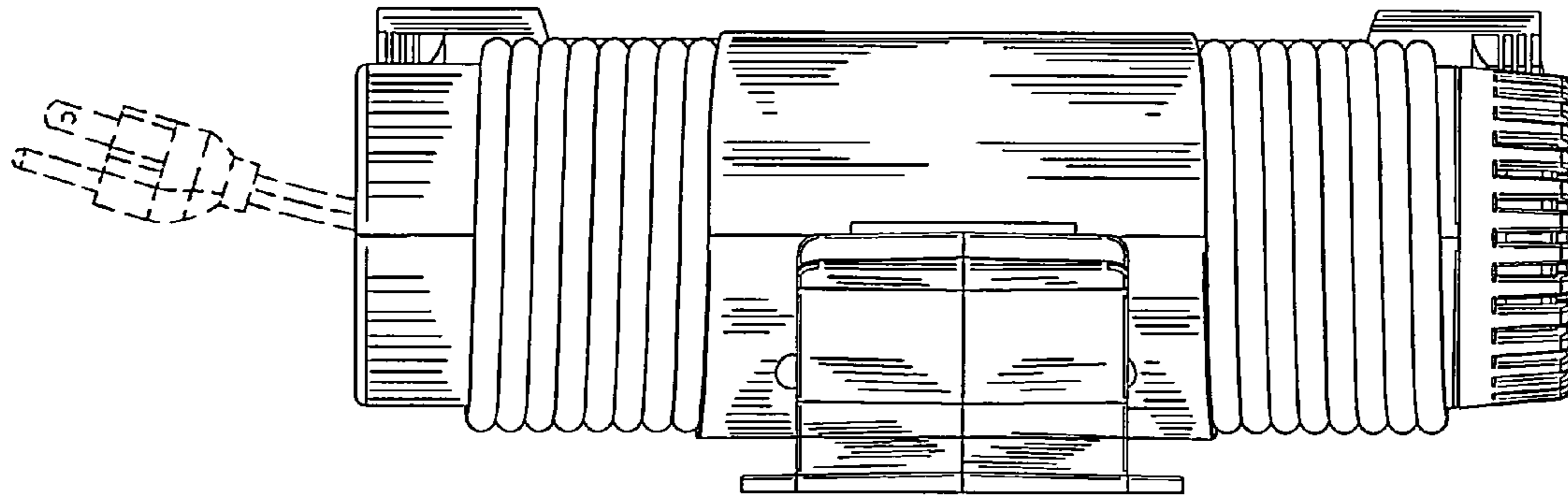

FIG. 20

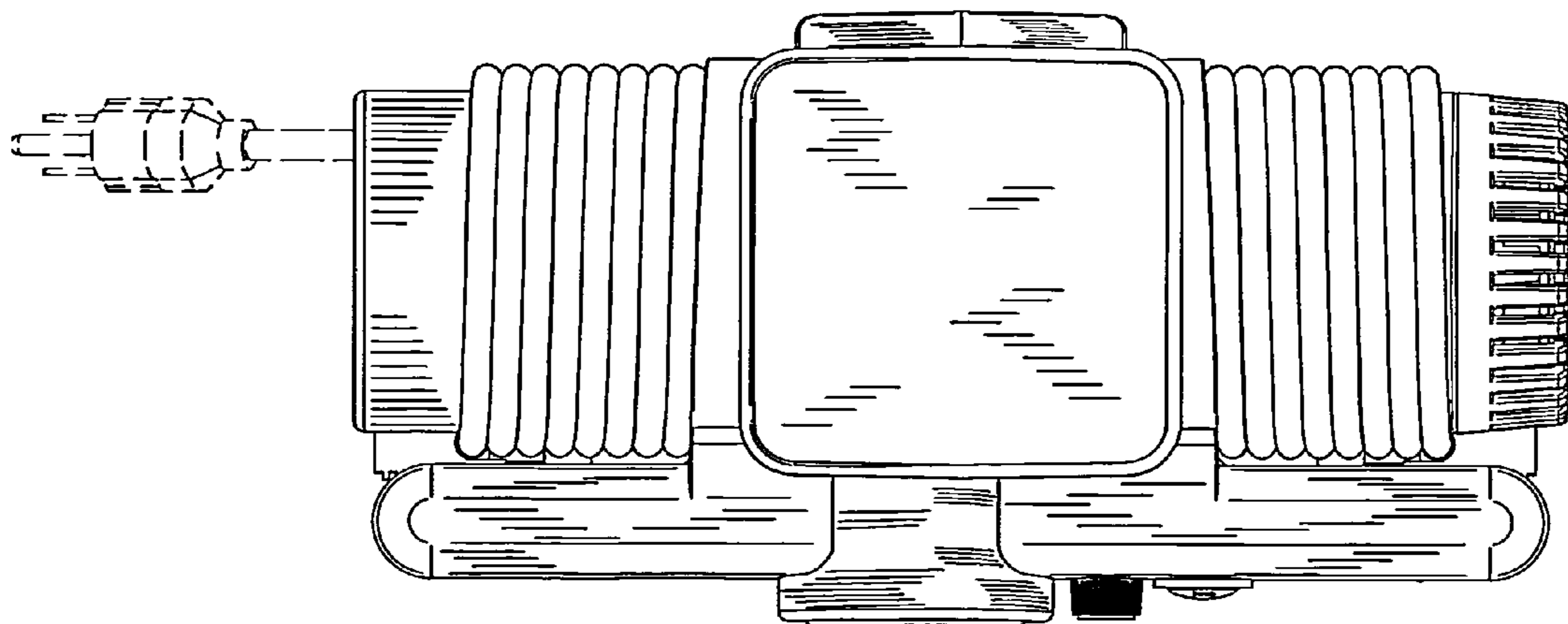

FIG. 21

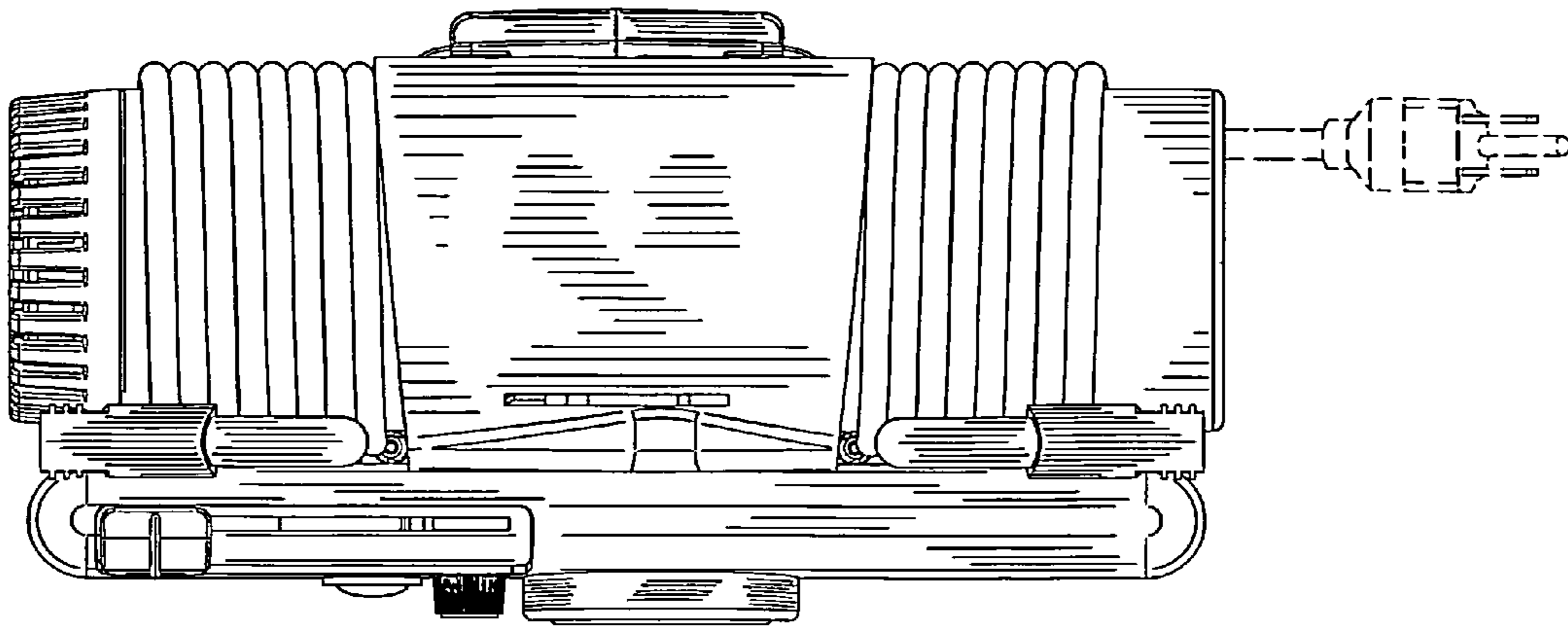

FIG. 22

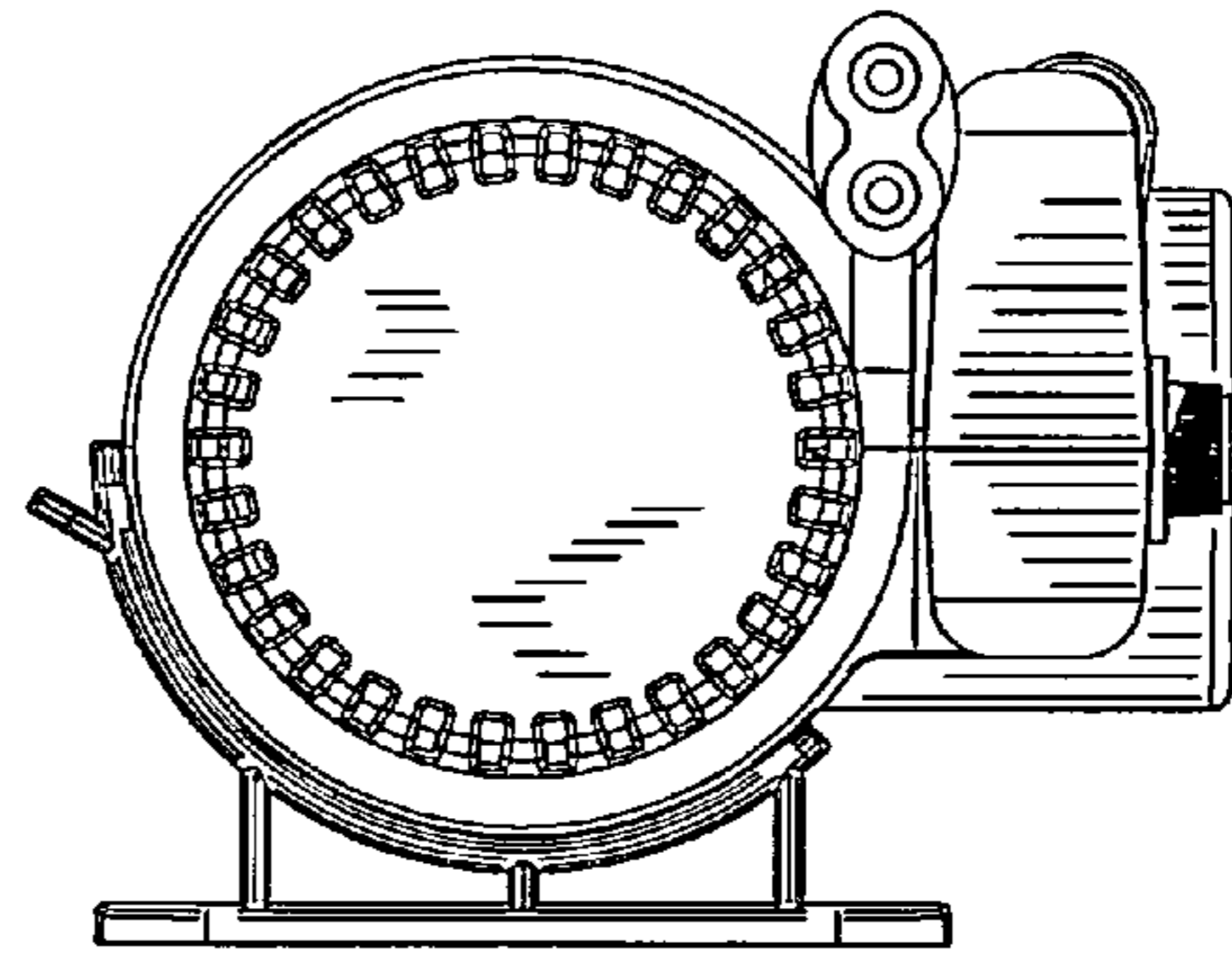

FIG. 23

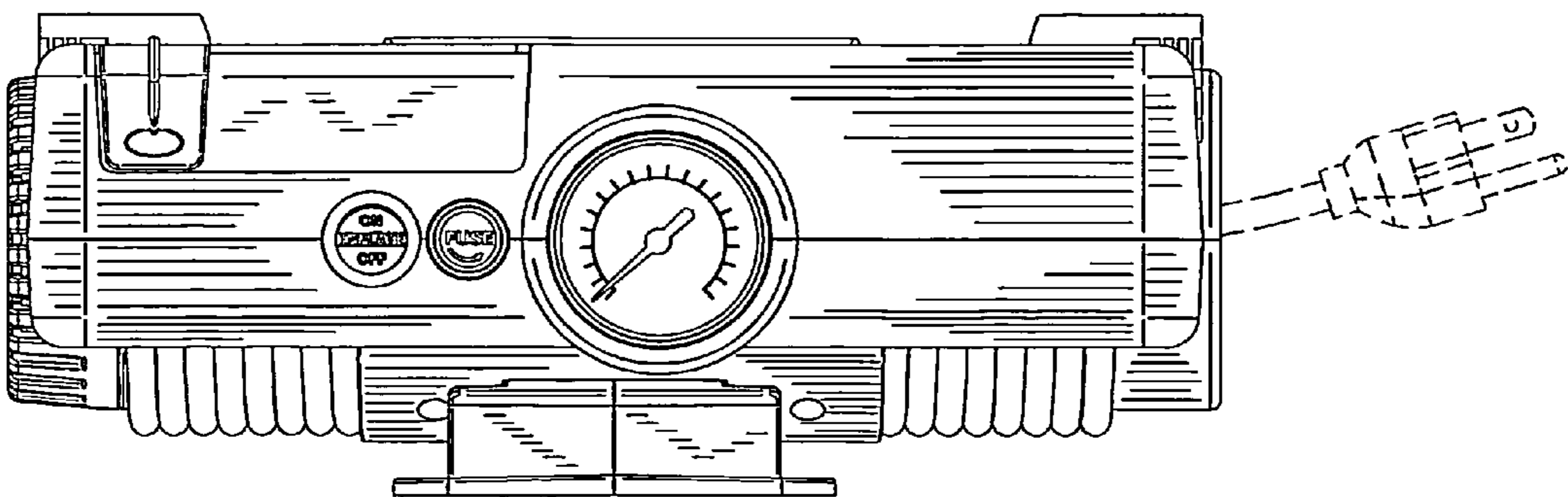

FIG. 24

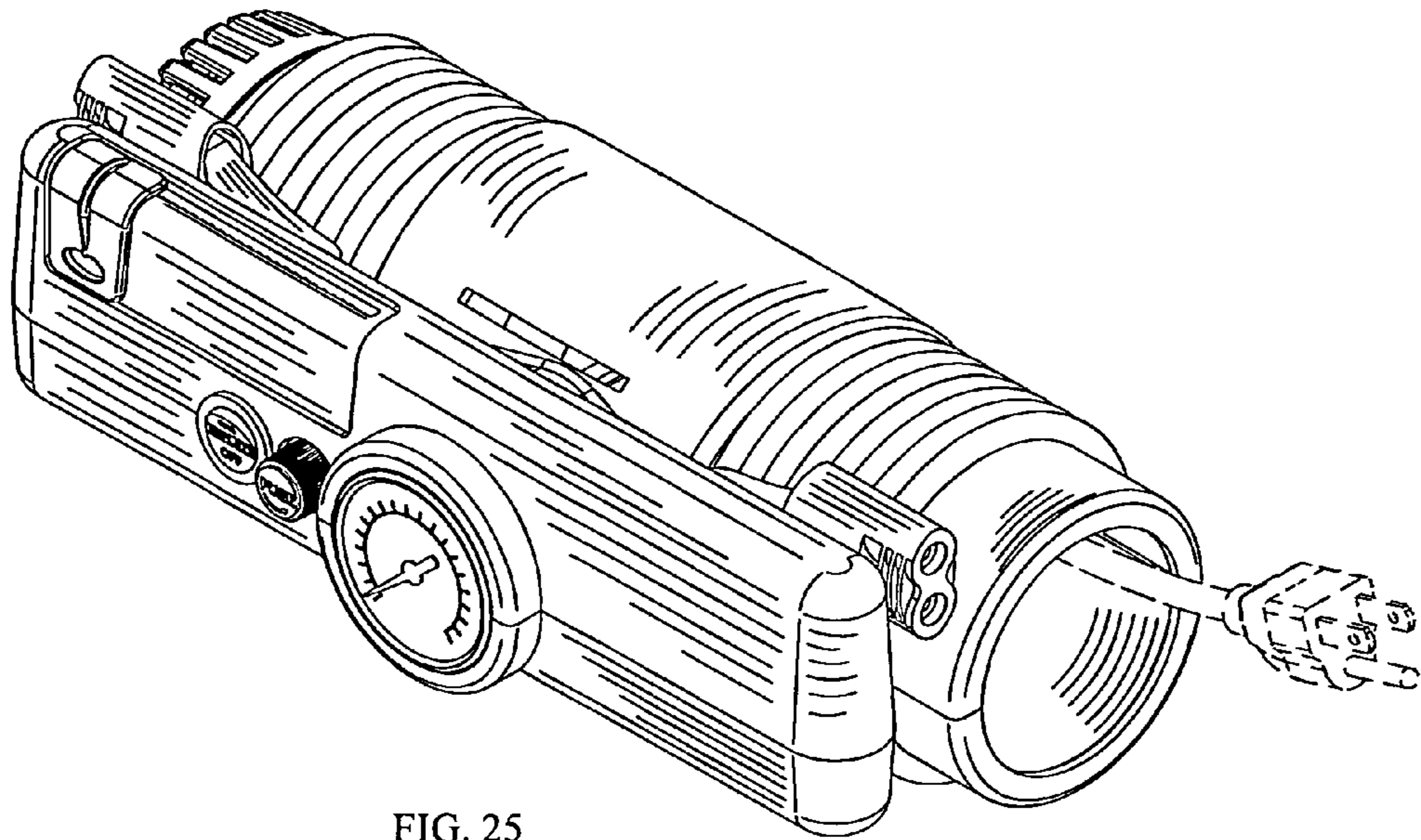

FIG. 25

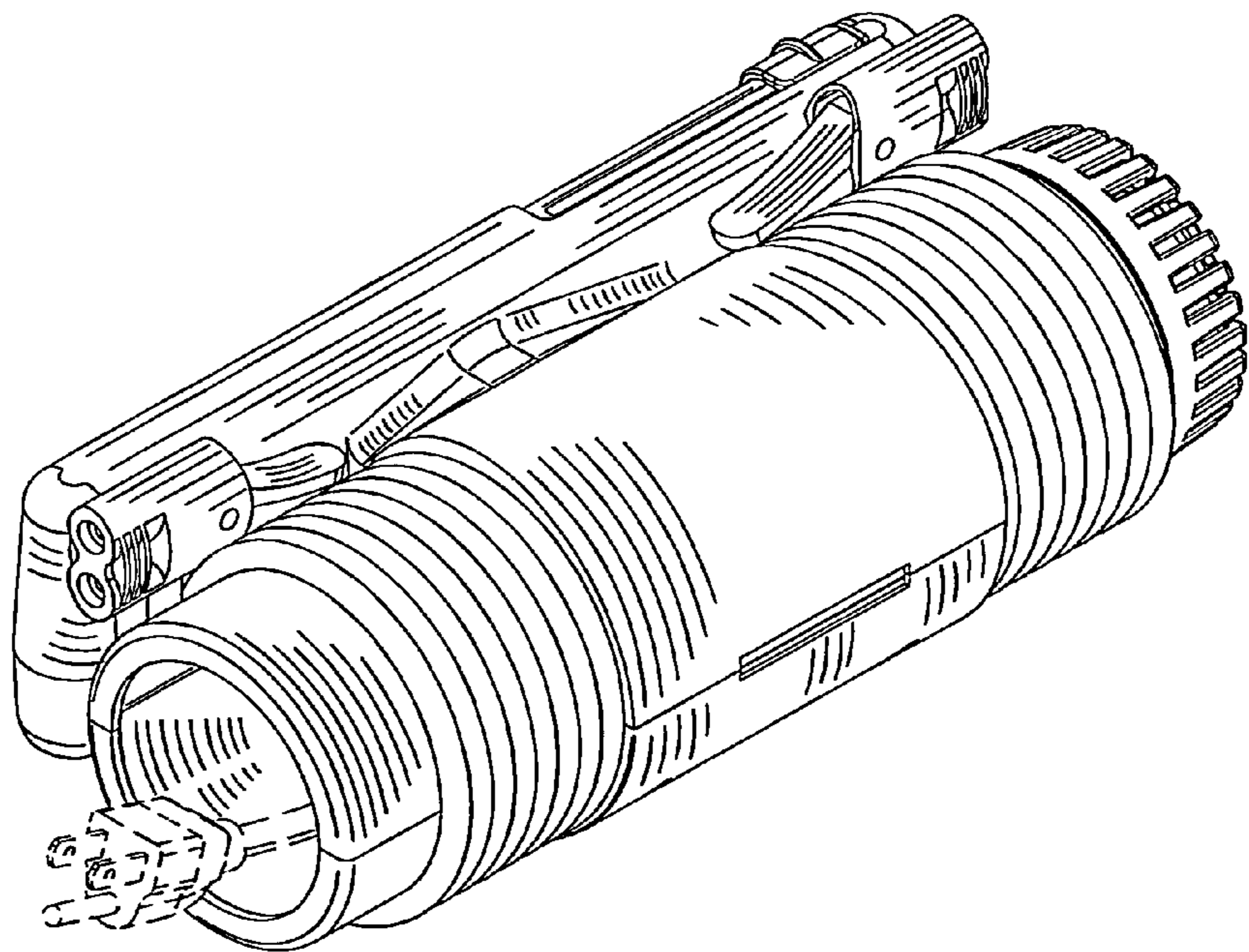

FIG. 26

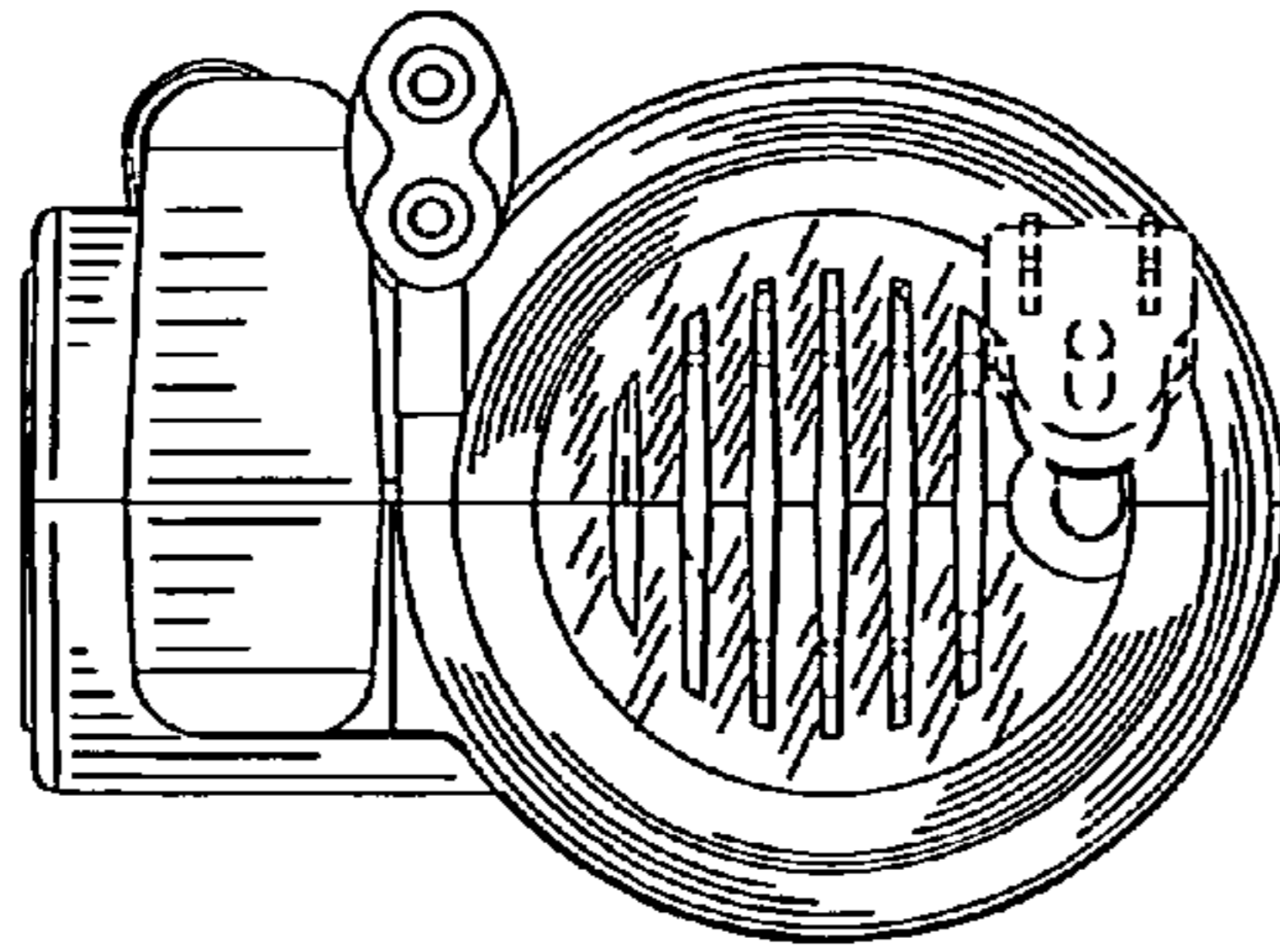

FIG. 27

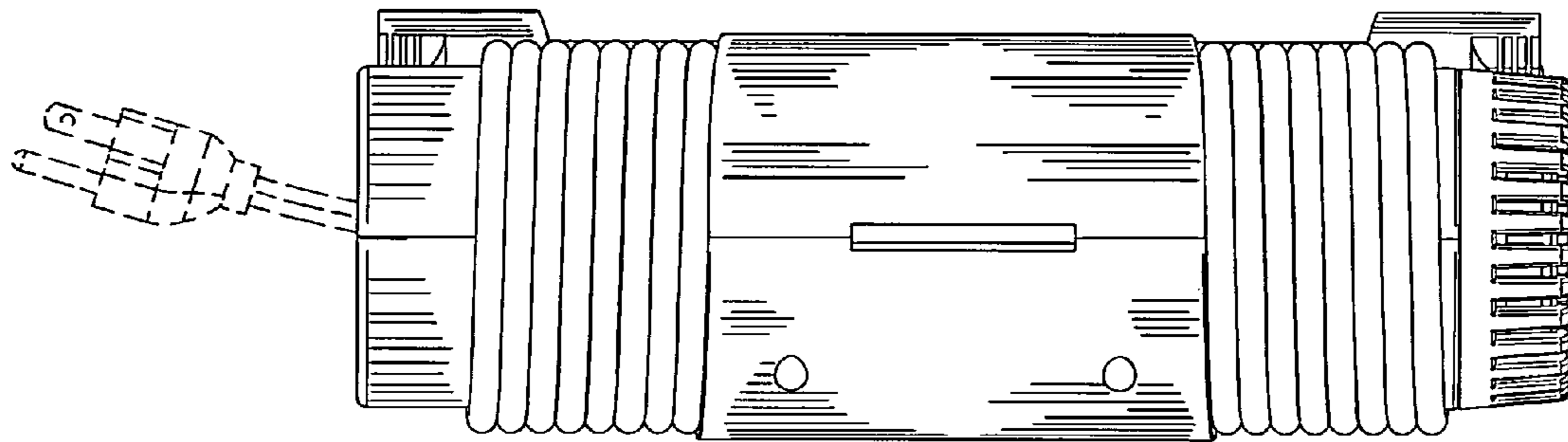

FIG. 28

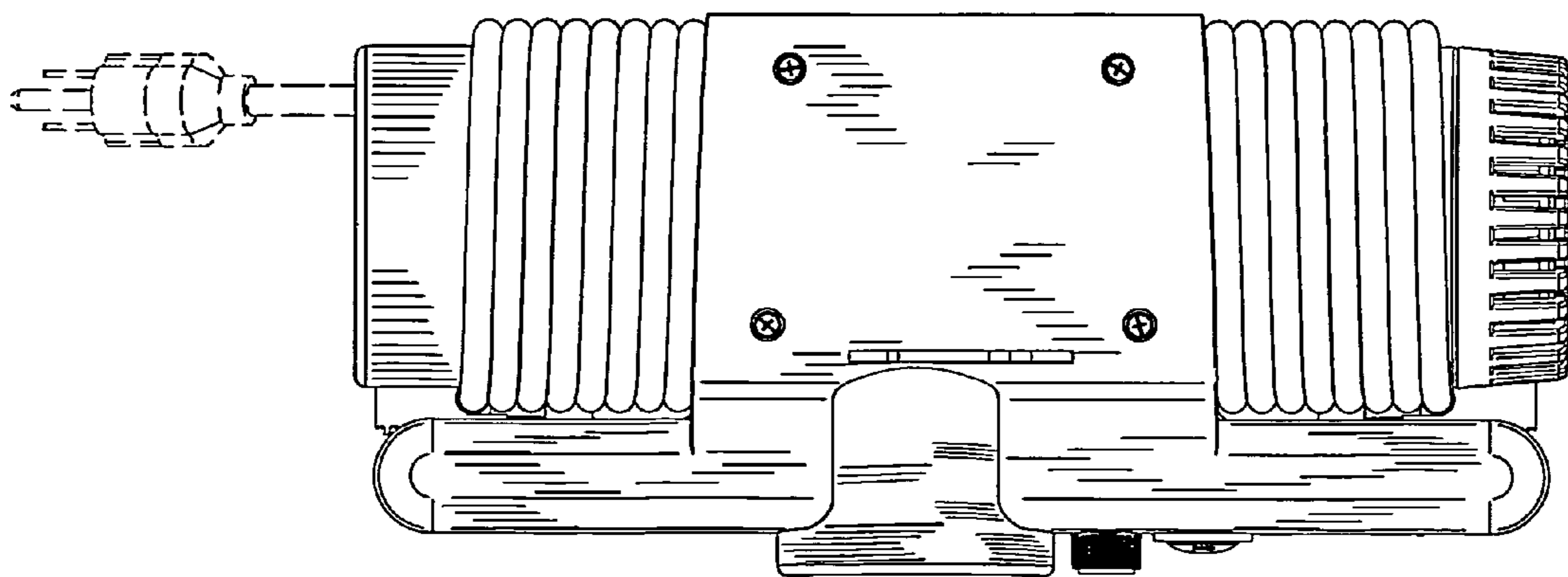

FIG. 29

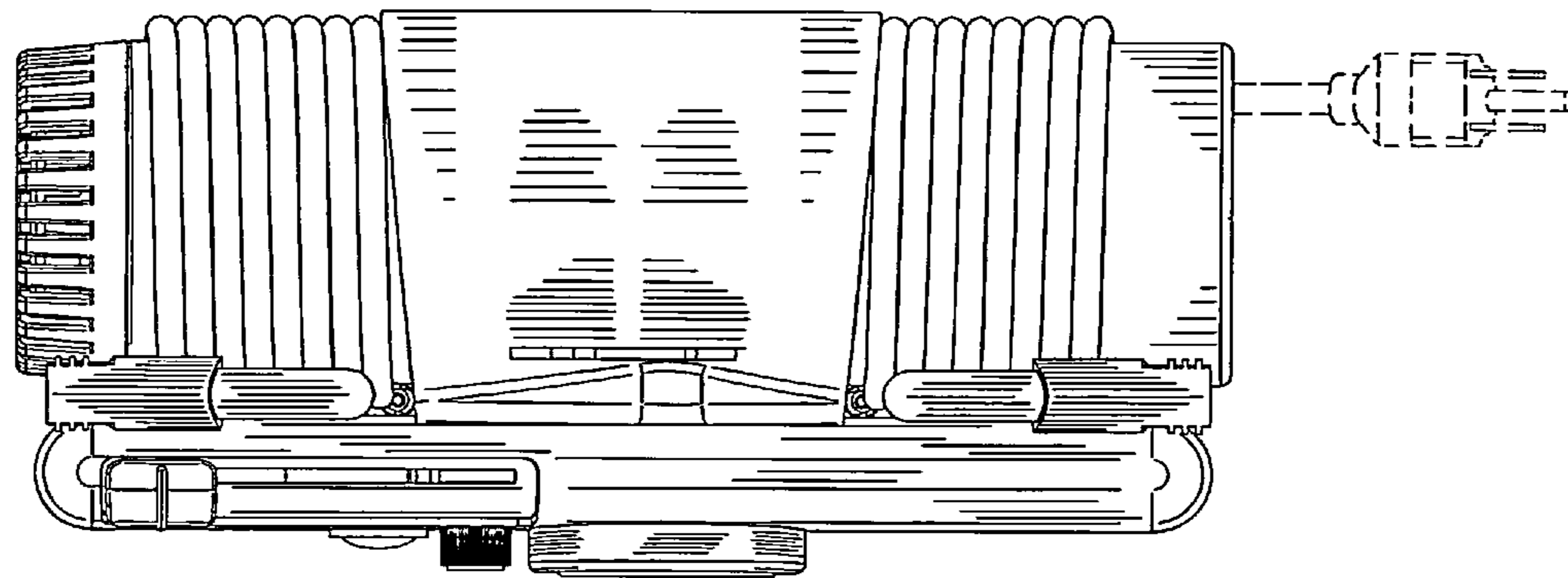

FIG. 30

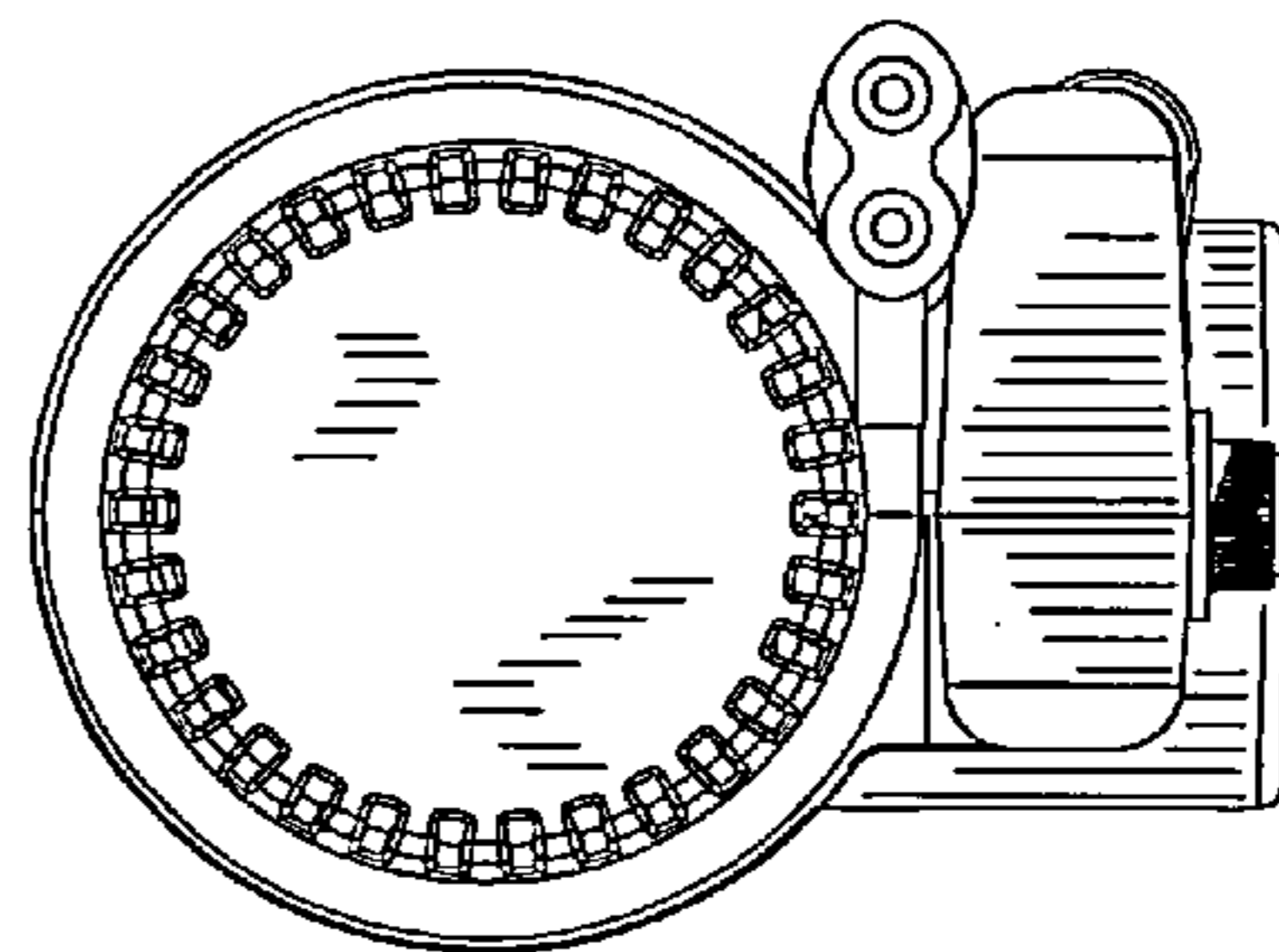

FIG. 31

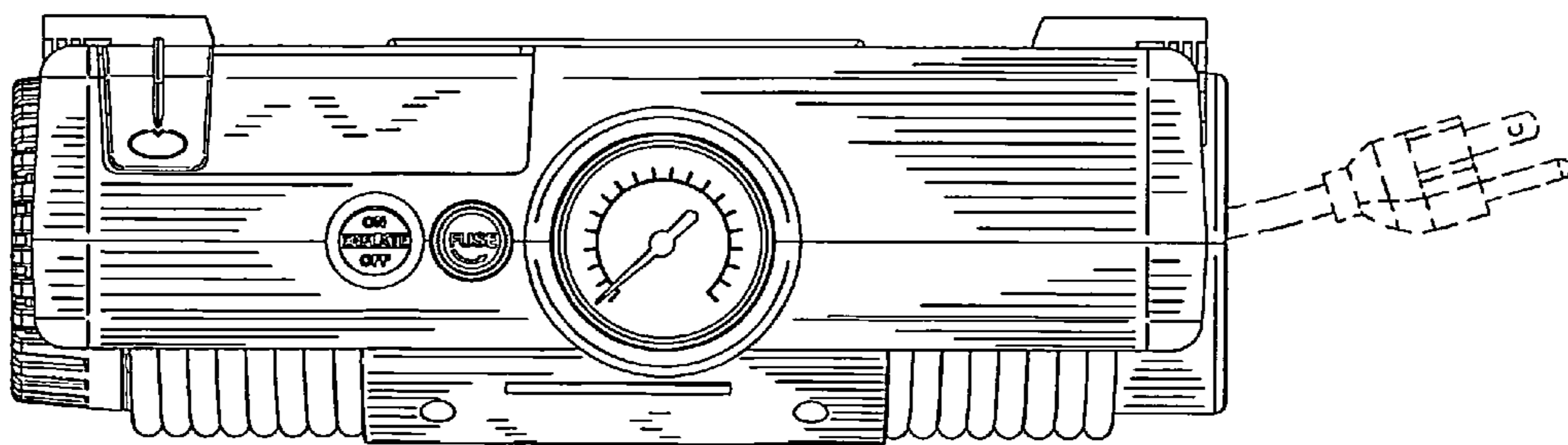

FIG. 32

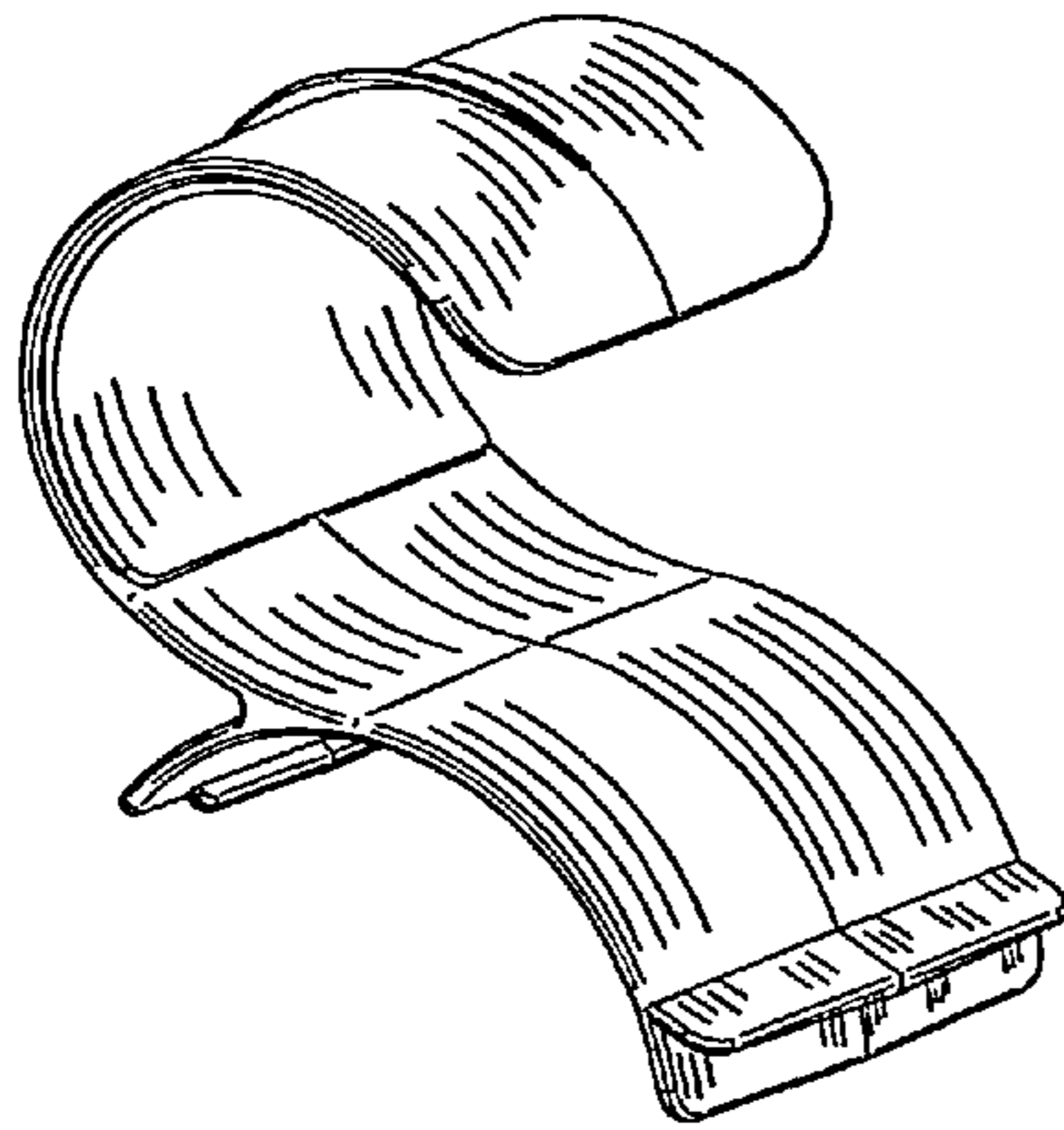

FIG. 33

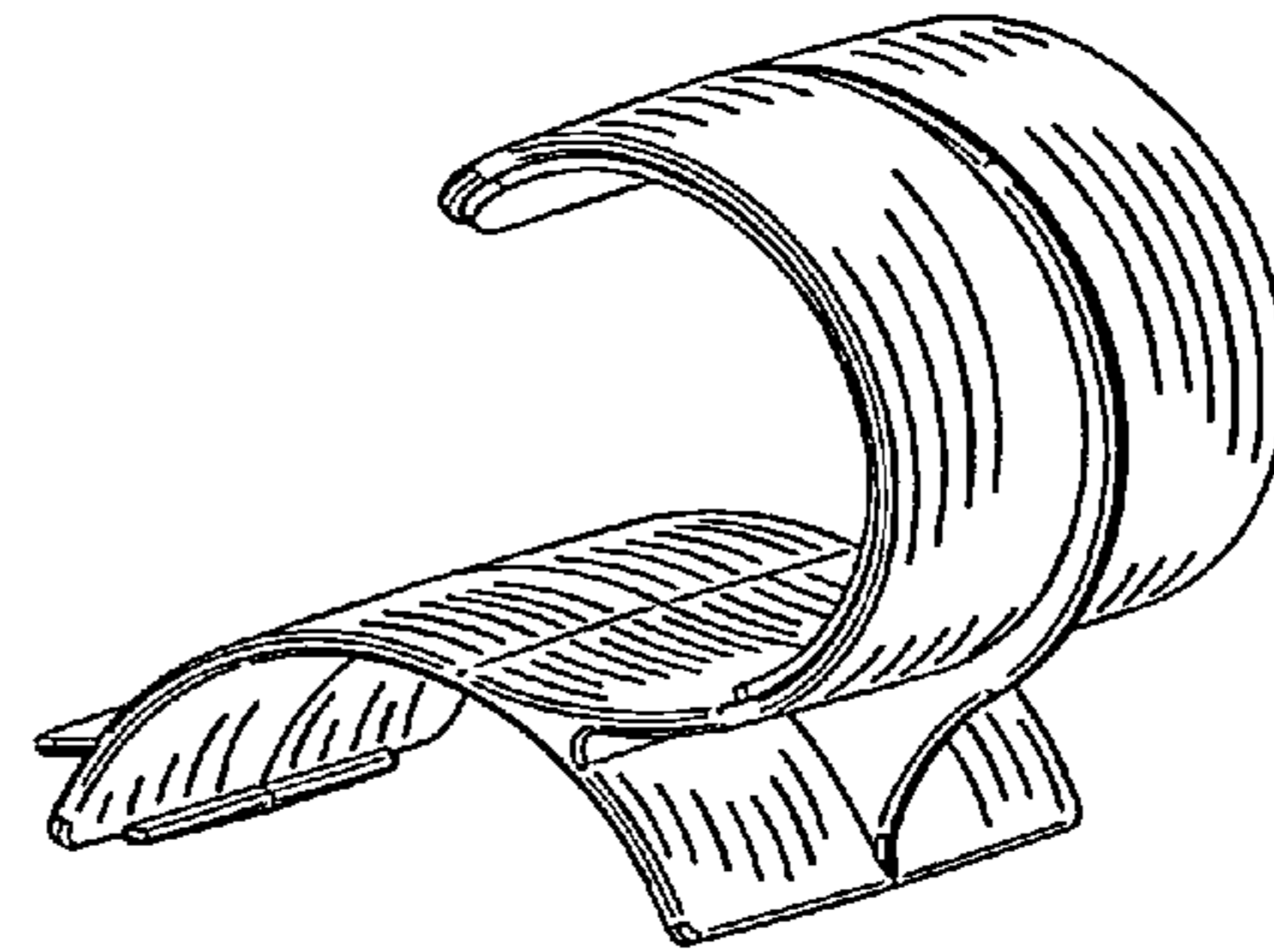

FIG. 34

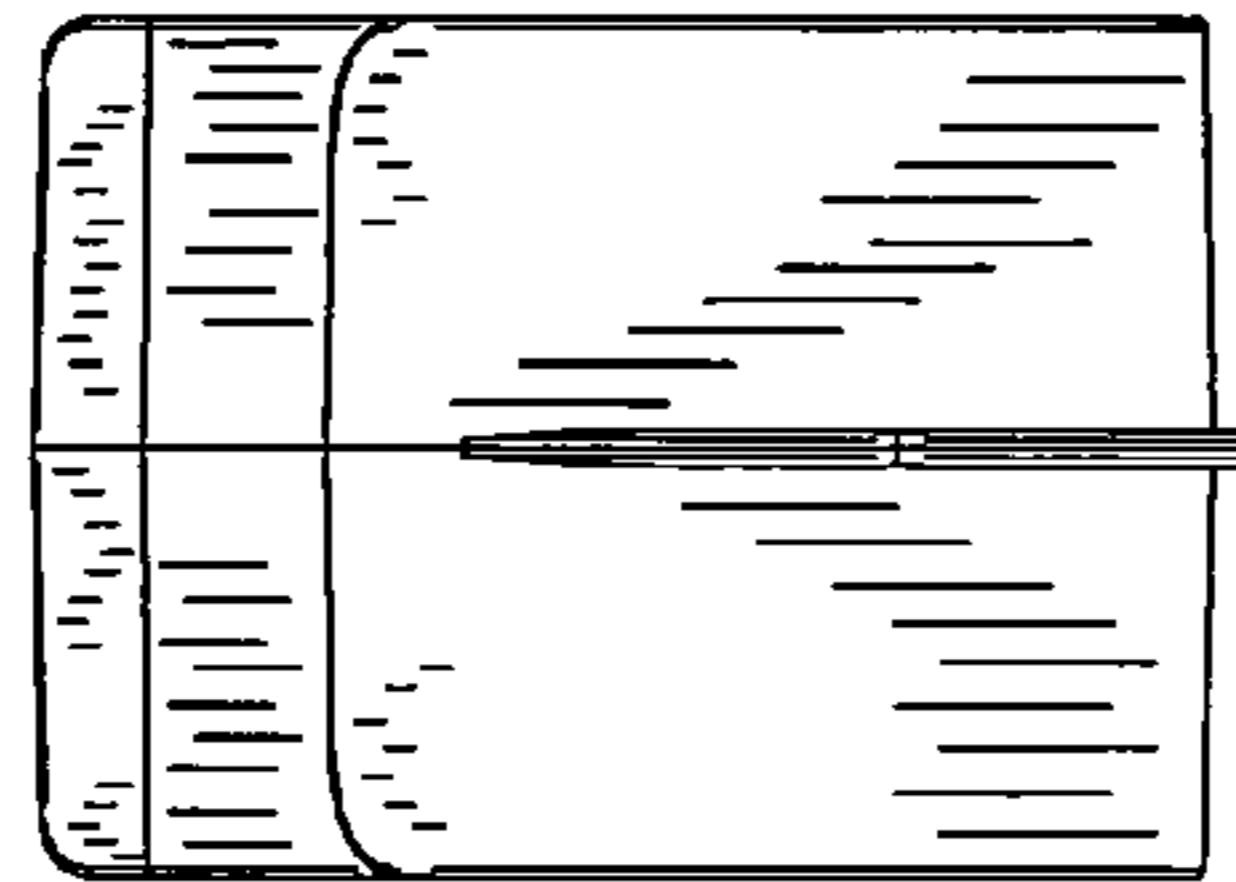

FIG. 35

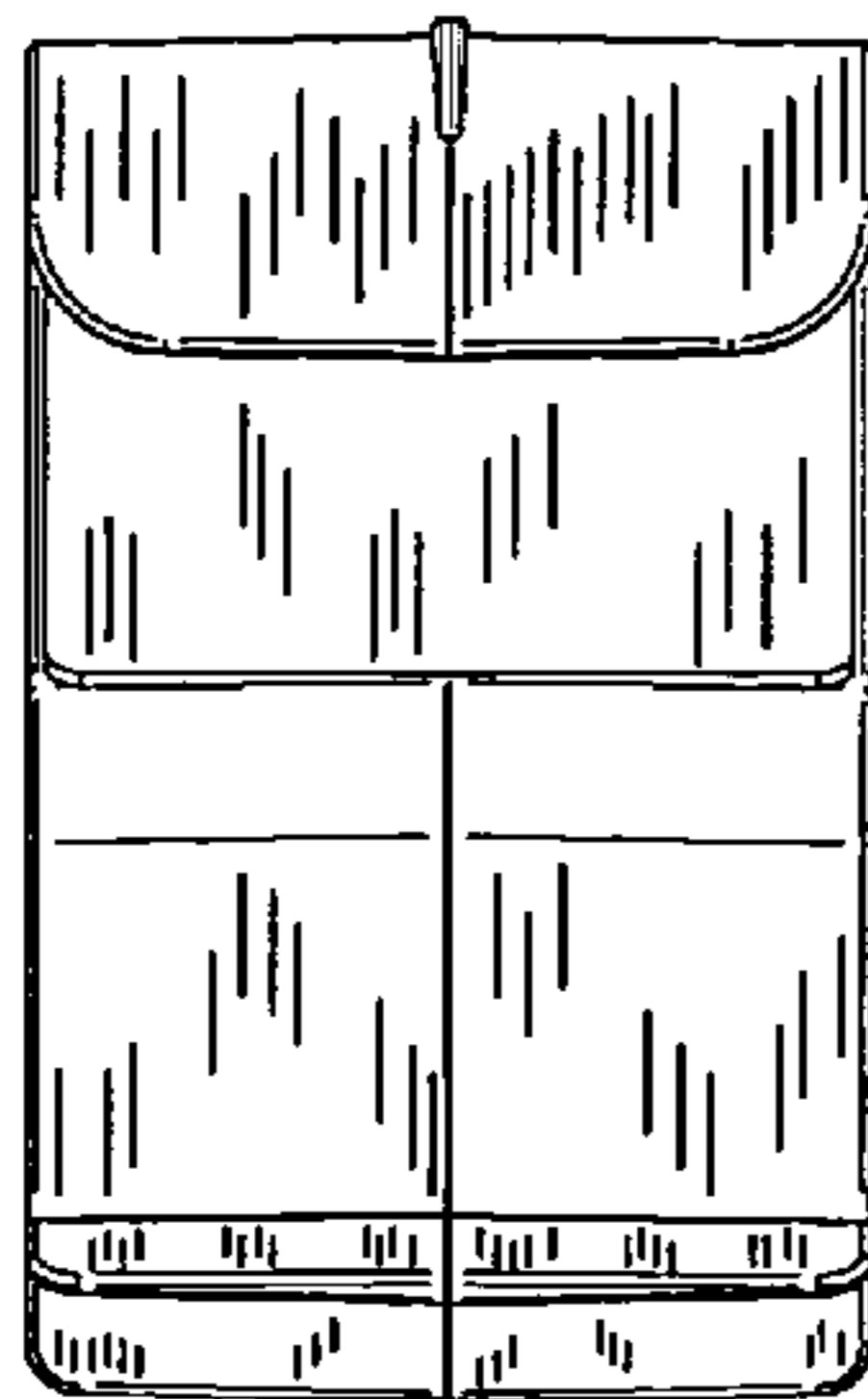

FIG. 36

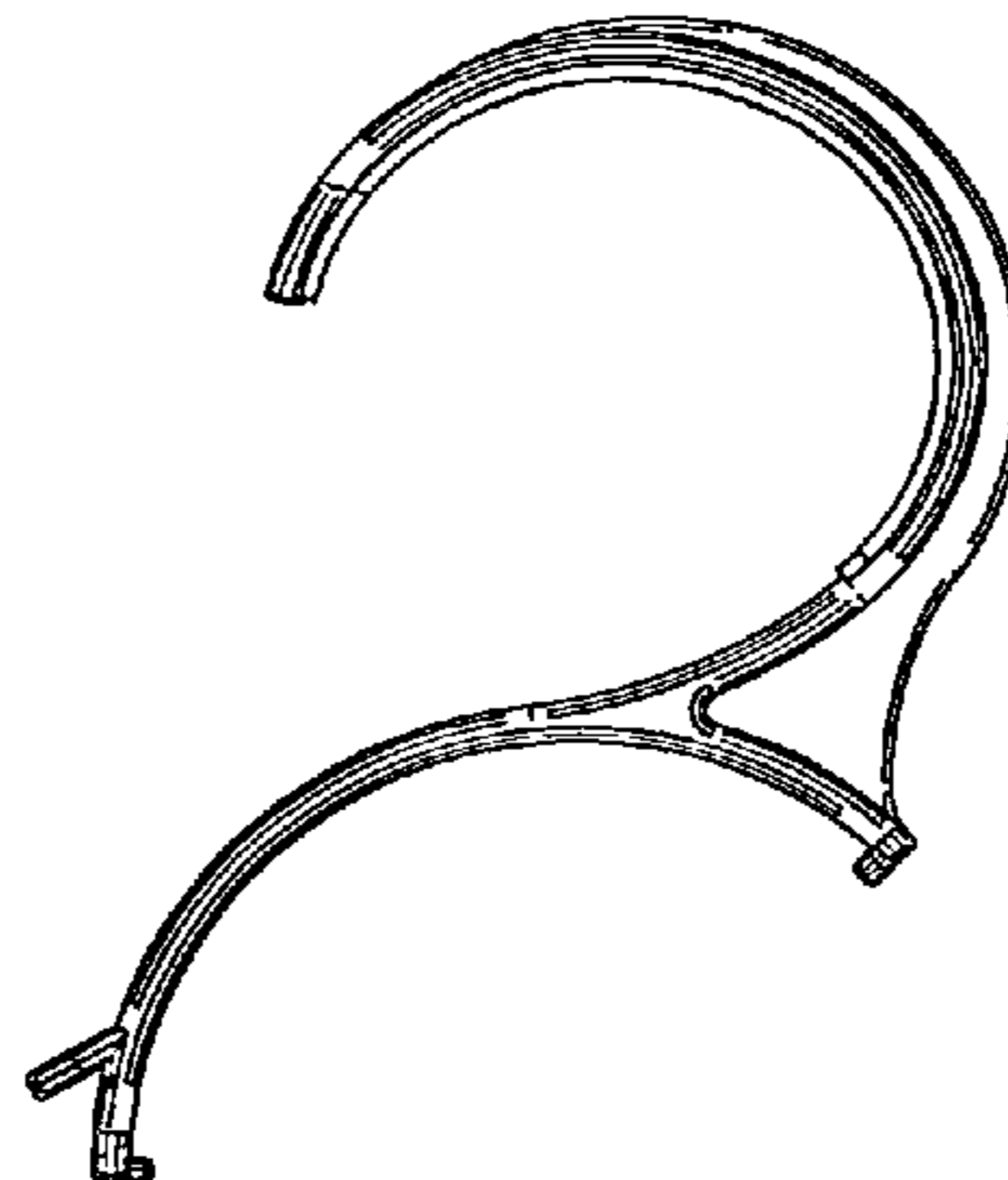

FIG. 37

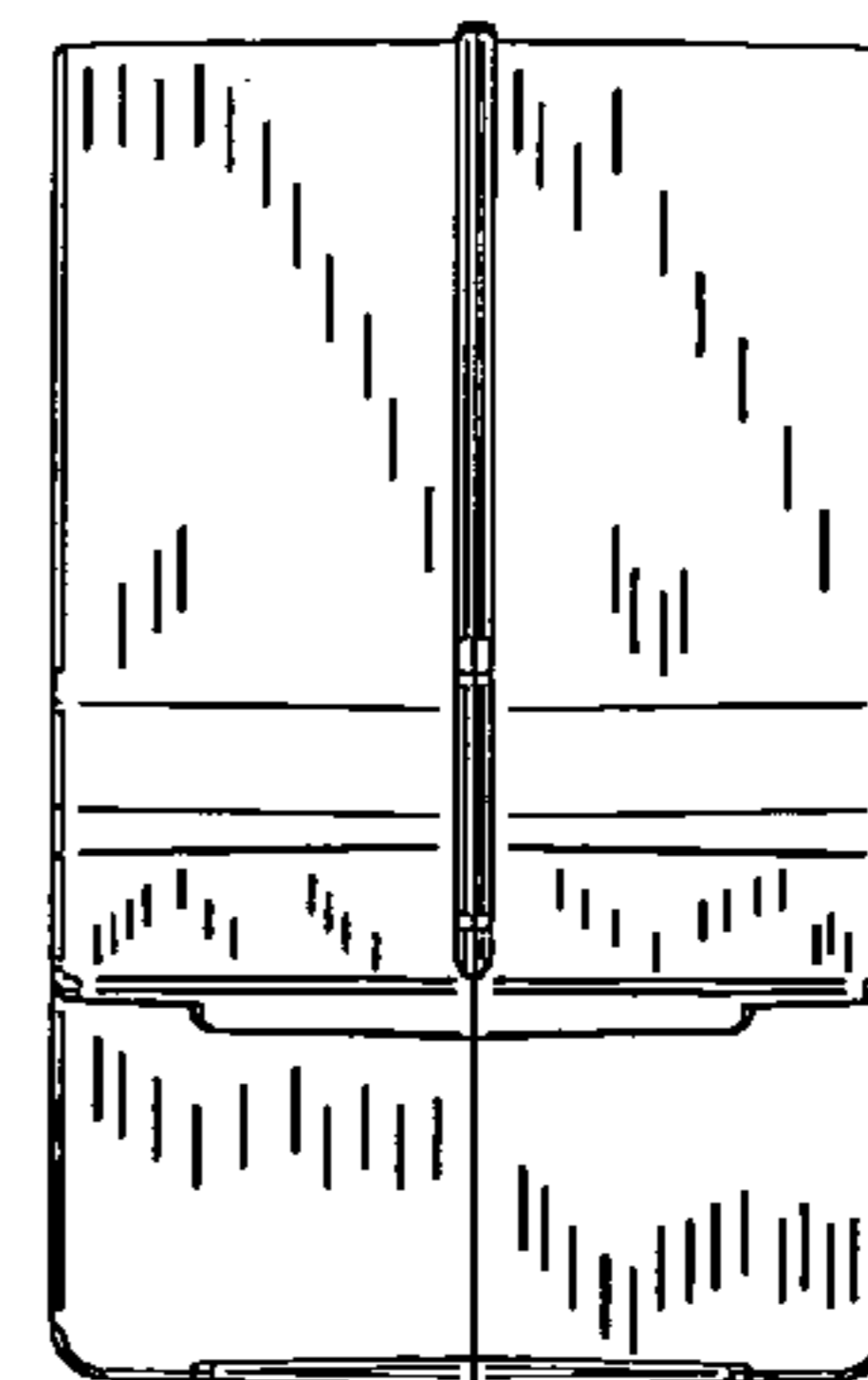

FIG. 38

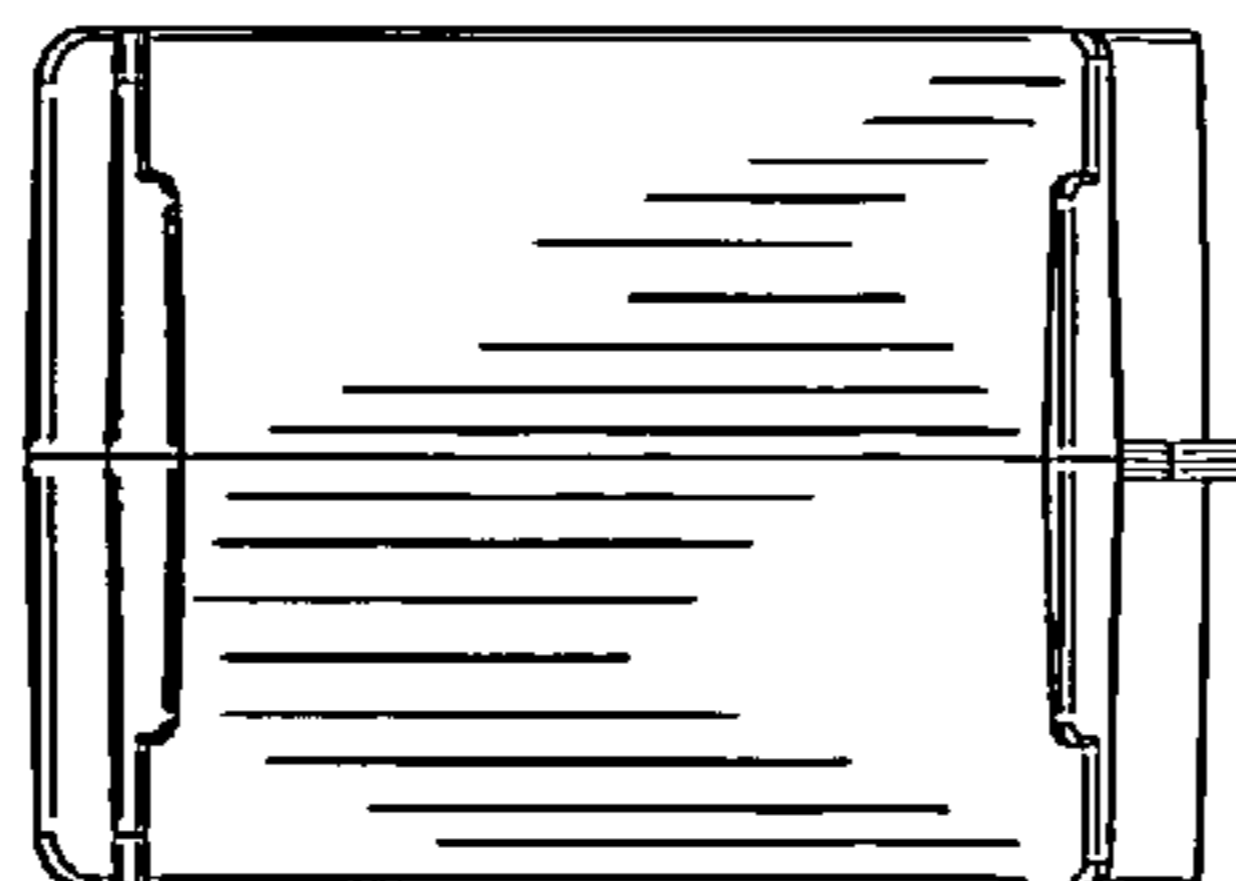

FIG. 39

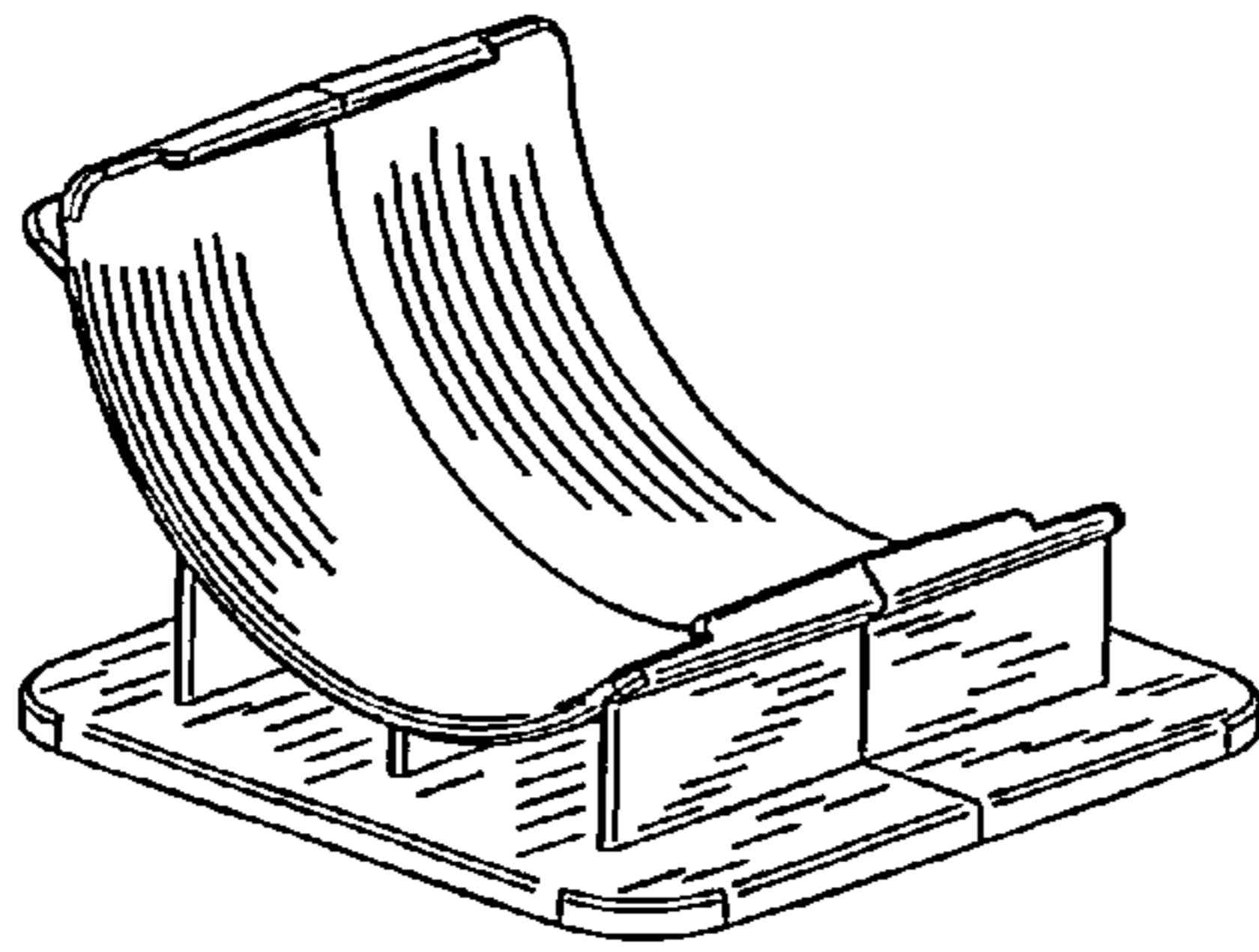

FIG. 40

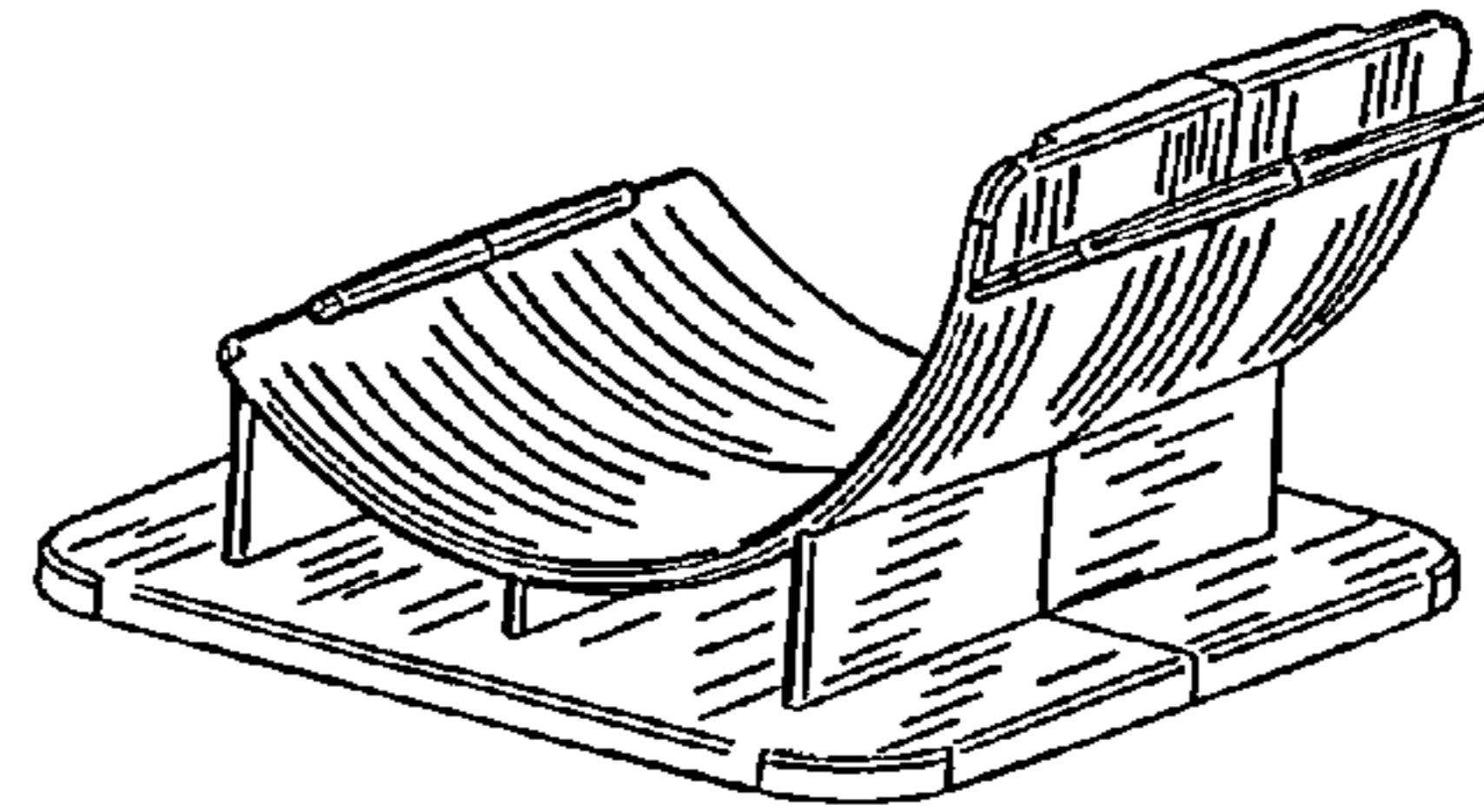

FIG. 41

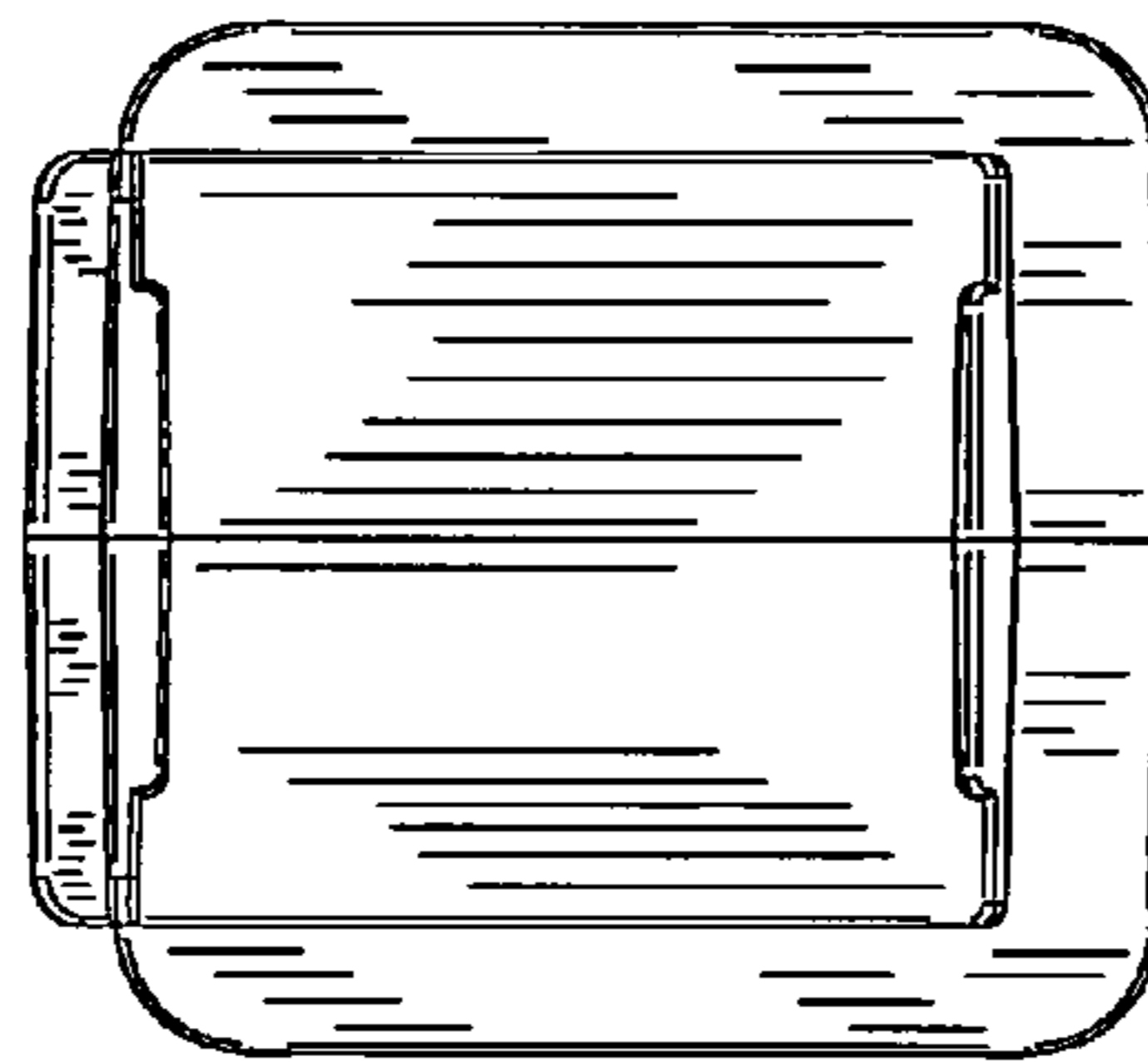

FIG. 42

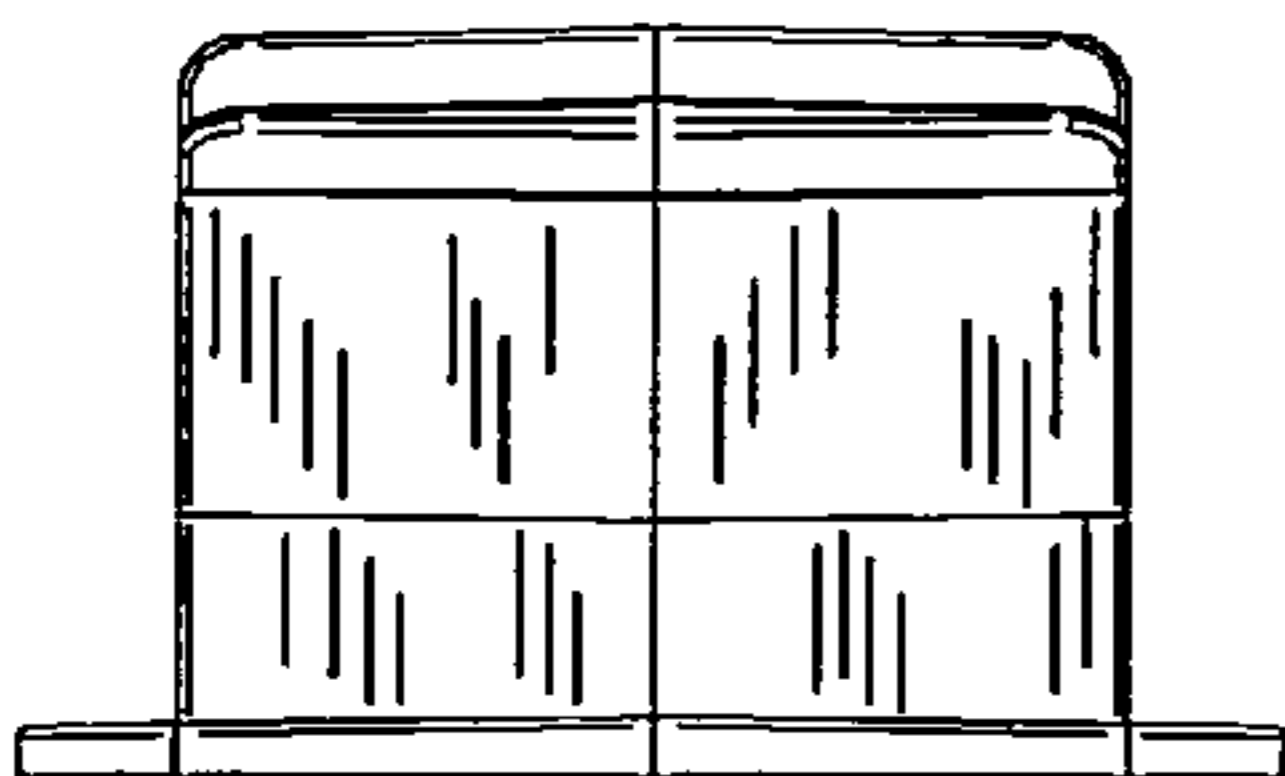

FIG. 43

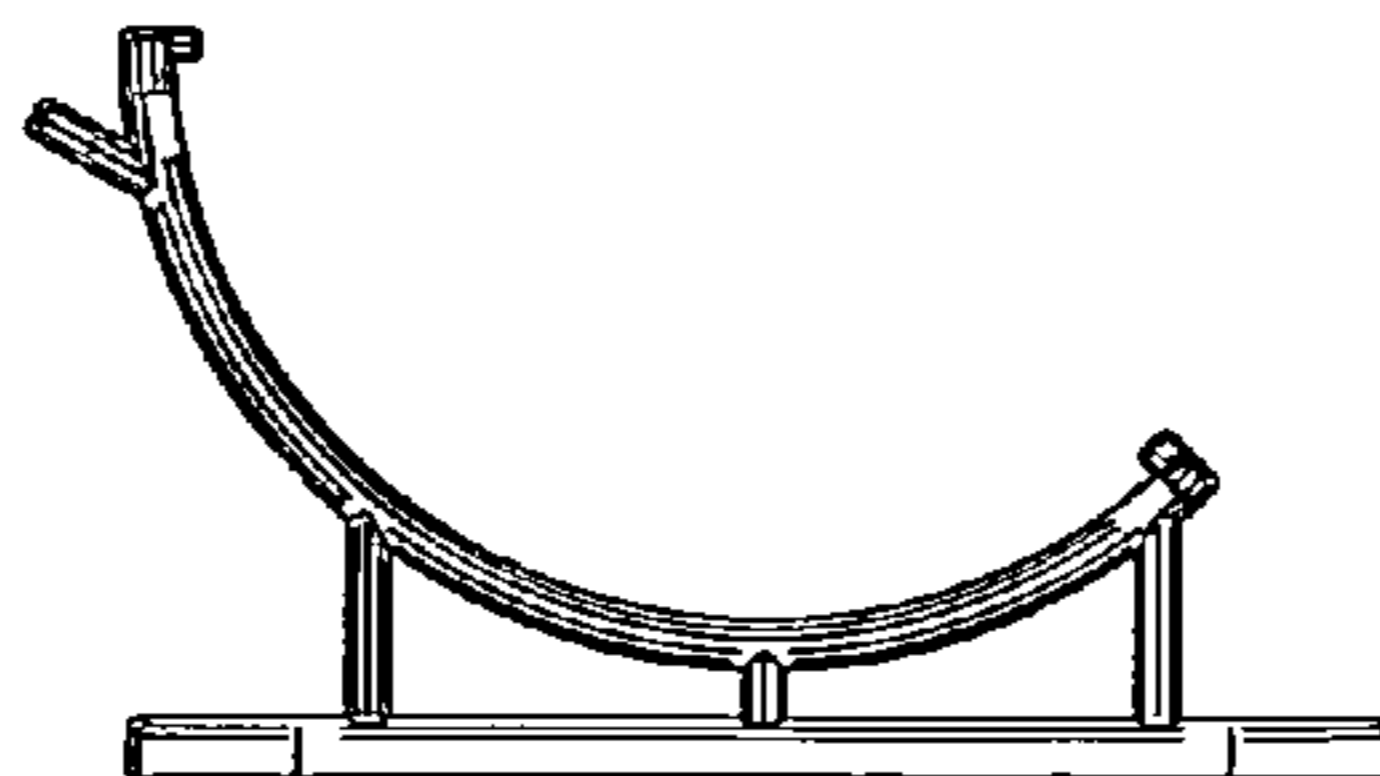

FIG. 44

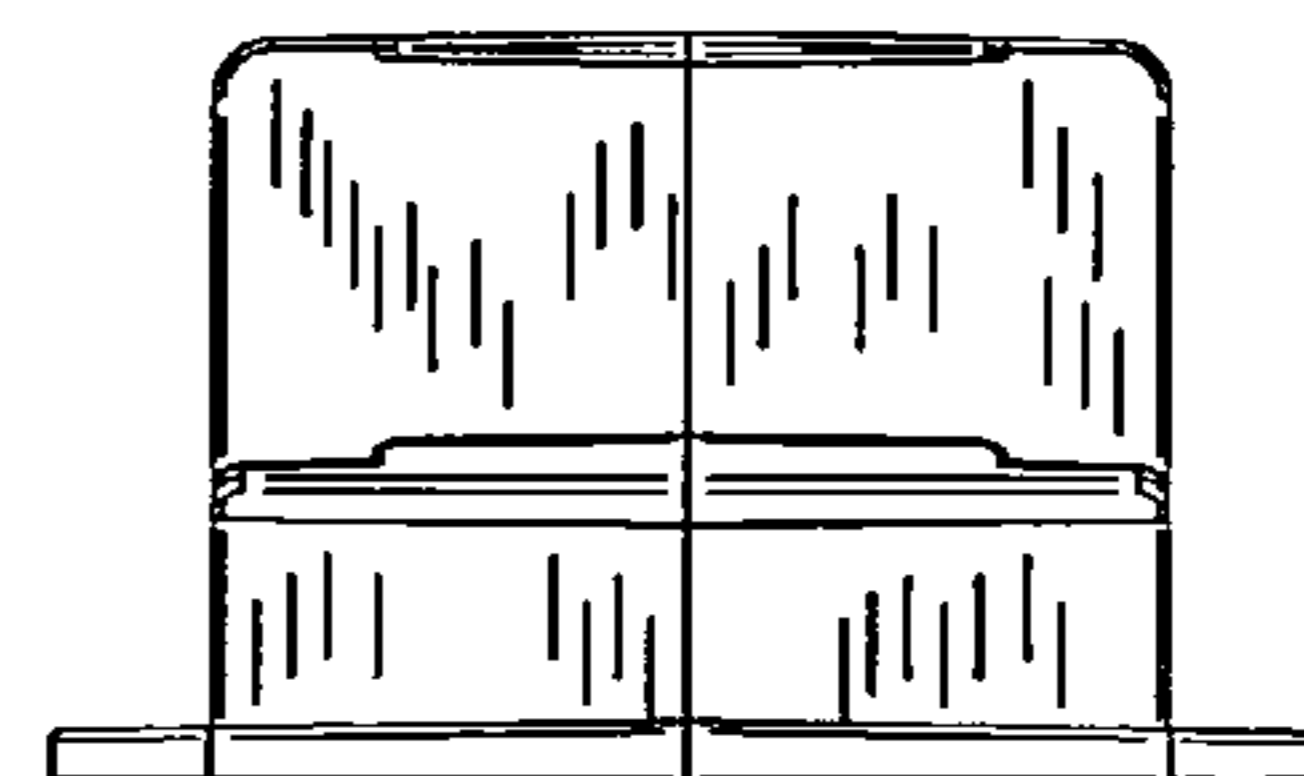

FIG. 45

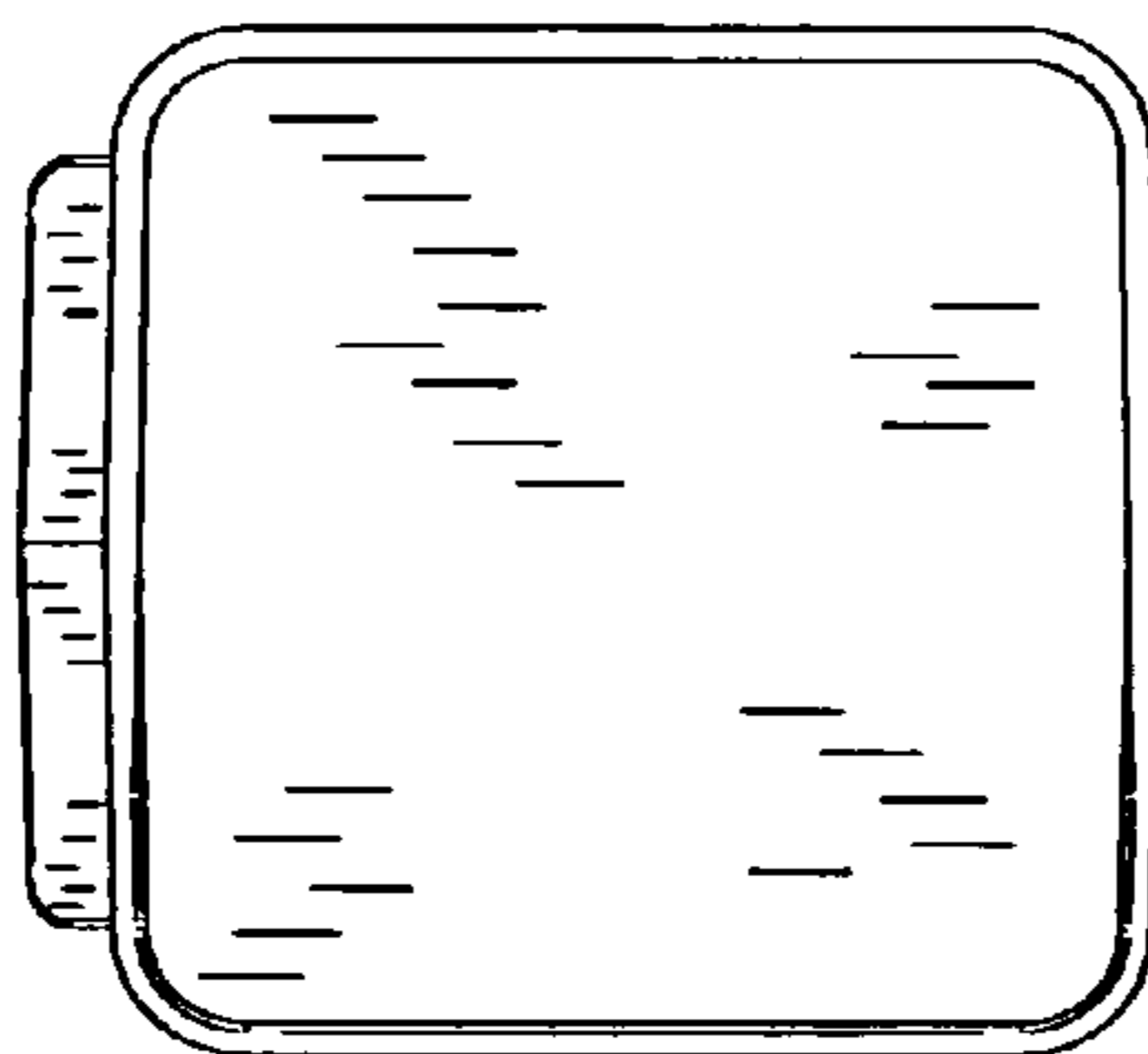

FIG. 46