



US00D739311S

(12) **United States Design Patent**
Schanz et al.

(10) **Patent No.:** **US D739,311 S**

(45) **Date of Patent:** **** Sep. 22, 2015**

(54) **ENGINE GUARD FOR MOTORCYCLE**

(71) Applicant: **Touratech AG**, Niedereschach (DE)

(72) Inventors: **Jochen Schanz**, Niedereschach (DE);
Herbert Schwarz, Niedereschach (DE)

(73) Assignee: **TOURATECH AG**, Niedereschach (DE)

(**) Term: **14 Years**

(21) Appl. No.: **29/460,578**

(22) Filed: **Jul. 12, 2013**

(30) **Foreign Application Priority Data**

Jan. 14, 2013 (EP) 001357297 0001

(51) **LOC (10) Cl.** **12-11**

(52) **U.S. Cl.**
USPC **D12/114**

(58) **Field of Classification Search**
USPC 181/231; 180/219, 220, 311, 231;
280/124, 128, 304.3; 303/115.4;
D12/126, 190, 114; 296/198; 74/607;
192/70.11; 362/473; 60/533, 585;
188/344; 340/438; 123/196 R, 90.1;
211/21
CPC B62K 11/04; B62K 2202/00; B62K
2204/00; B62K 5/01; B62K 11/00; B60T
8/4225

See application file for complete search history.

(56) **References Cited**

U.S. PATENT DOCUMENTS

D297,229 S * 8/1988 Sermersheim D12/190
D488,415 S * 4/2004 Gough D12/190

7,464,954 B2 * 12/2008 Grow 280/304.3
D637,529 S * 5/2011 Burns et al. D12/126
2002/0185323 A1 * 12/2002 Tsutsumi et al. 180/219
2007/0266968 A1 * 11/2007 Hanold et al. 123/90.1
2007/0266987 A1 * 11/2007 Hanold et al. 123/196 R
2008/0054597 A1 * 3/2008 Becker 280/304.3
2008/0079310 A1 * 4/2008 Yamakura et al. 303/115.4
2009/0001031 A1 * 1/2009 Hutchinson, II 211/21
2009/0058030 A1 * 3/2009 Fujita et al. 280/124.128
2010/0126306 A1 * 5/2010 Ito et al. 74/607
2010/0194149 A1 * 8/2010 Yamamoto 296/198
2011/0017560 A1 * 1/2011 Van Dyke et al. 188/344
2011/0088967 A1 * 4/2011 Tabata 181/231
2012/0073893 A1 * 3/2012 Muroo et al. 180/311
2012/0186245 A1 * 7/2012 Schmitt et al. 60/533
2013/0081894 A1 * 4/2013 Ishikawa et al. 180/220
2013/0168173 A1 * 7/2013 Kikuchi 180/220
2014/0060952 A1 * 3/2014 Mizukura 180/231
2014/0098552 A1 * 4/2014 Aron 362/473
2014/0102846 A1 * 4/2014 Raber et al. 192/70.11

* cited by examiner

Primary Examiner — Robert M Spear

Assistant Examiner — Ryan Harvey

(74) *Attorney, Agent, or Firm* — Tarolli, Sundheim, Covell
& Tummino LLP

(57) **CLAIM**

We claim the ornamental design for a engine guard for motor-
cycle, as shown and described.

DESCRIPTION

FIG. 1 is a perspective top view of a engine guard for motor-
cycle;

FIG. 2 is a bottom view of the guard; and,

FIG. 3 is a right hand side view of the guard.

1 Claim, 3 Drawing Sheets

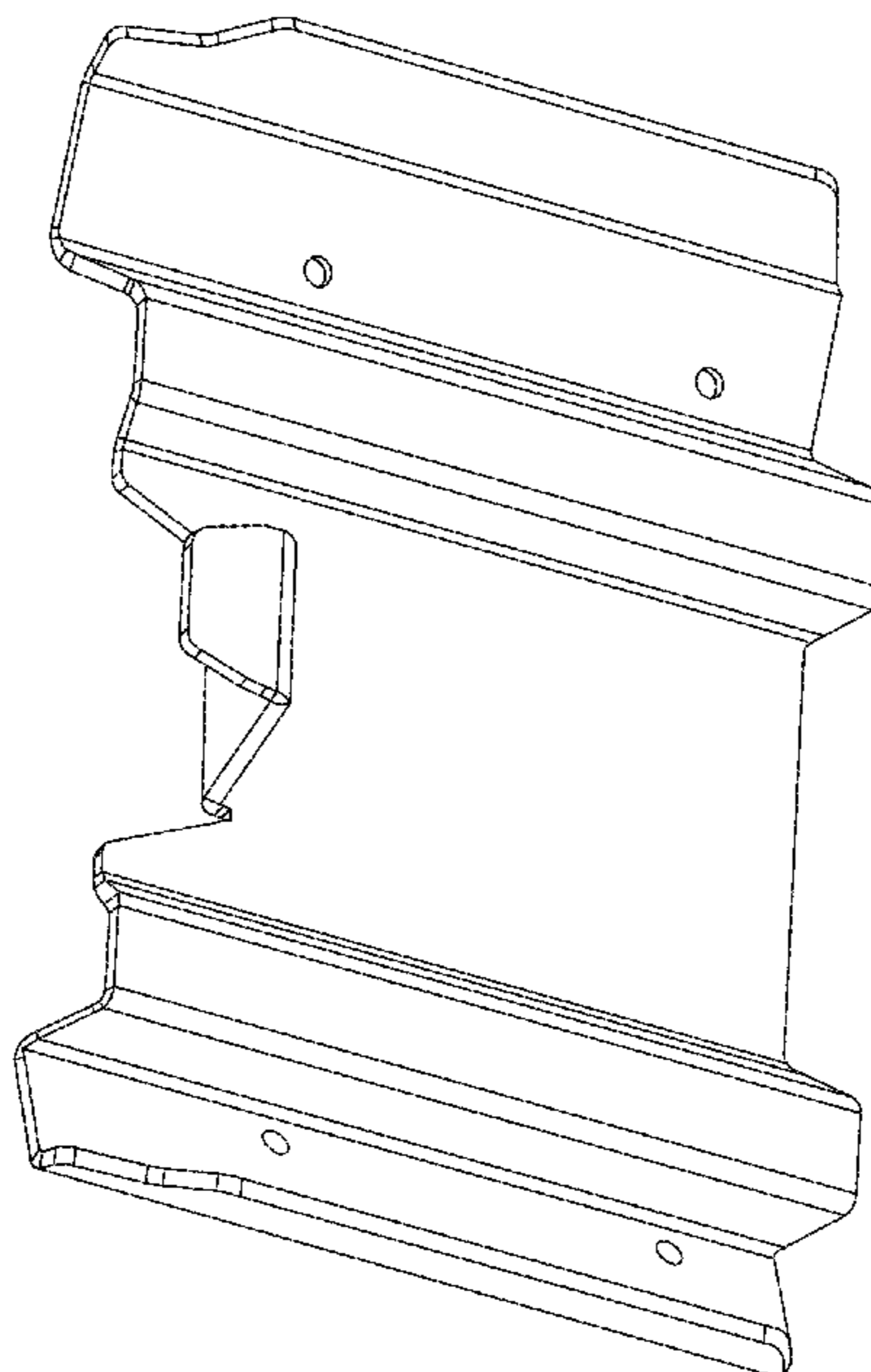

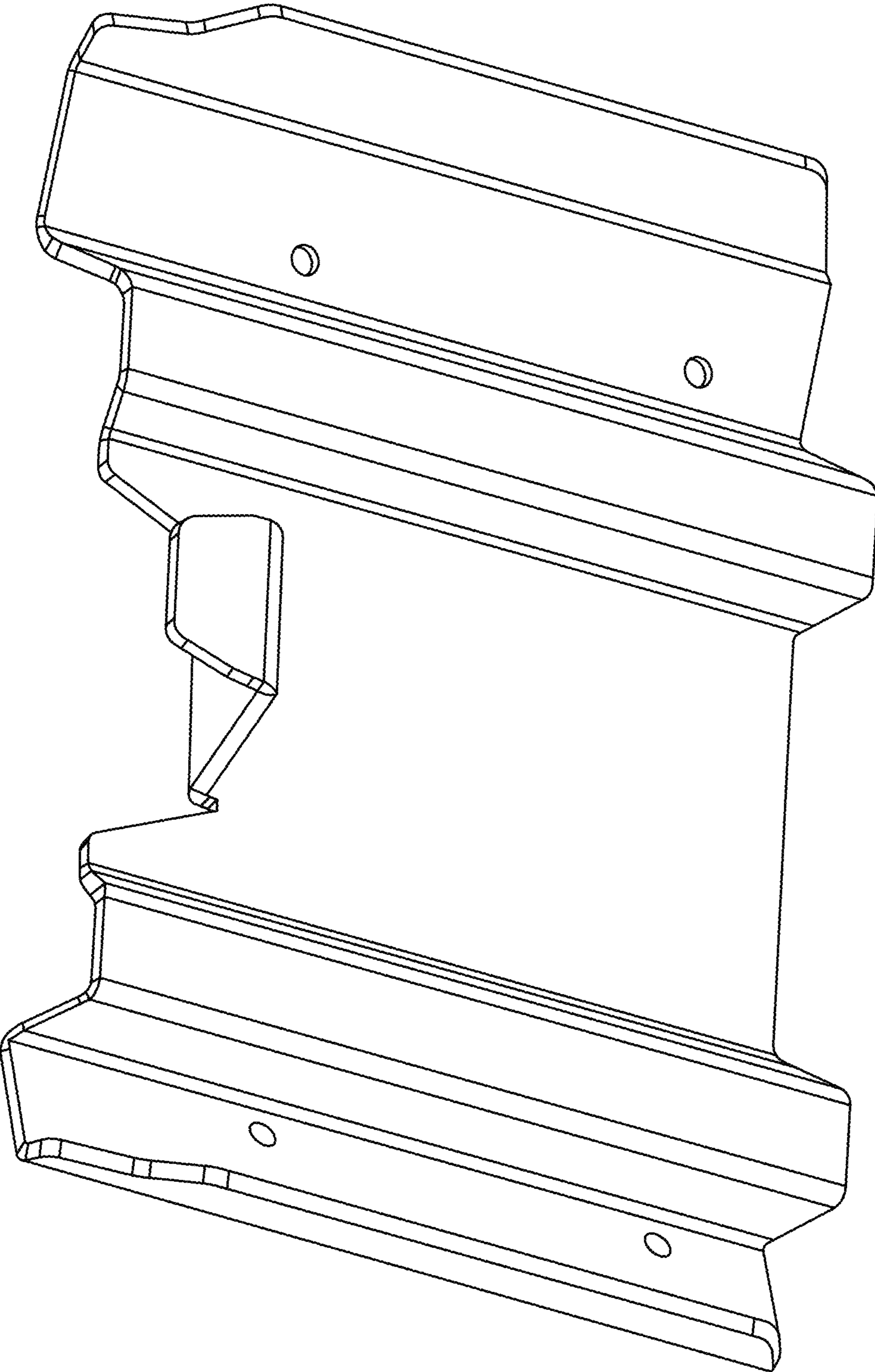

FIG. 1

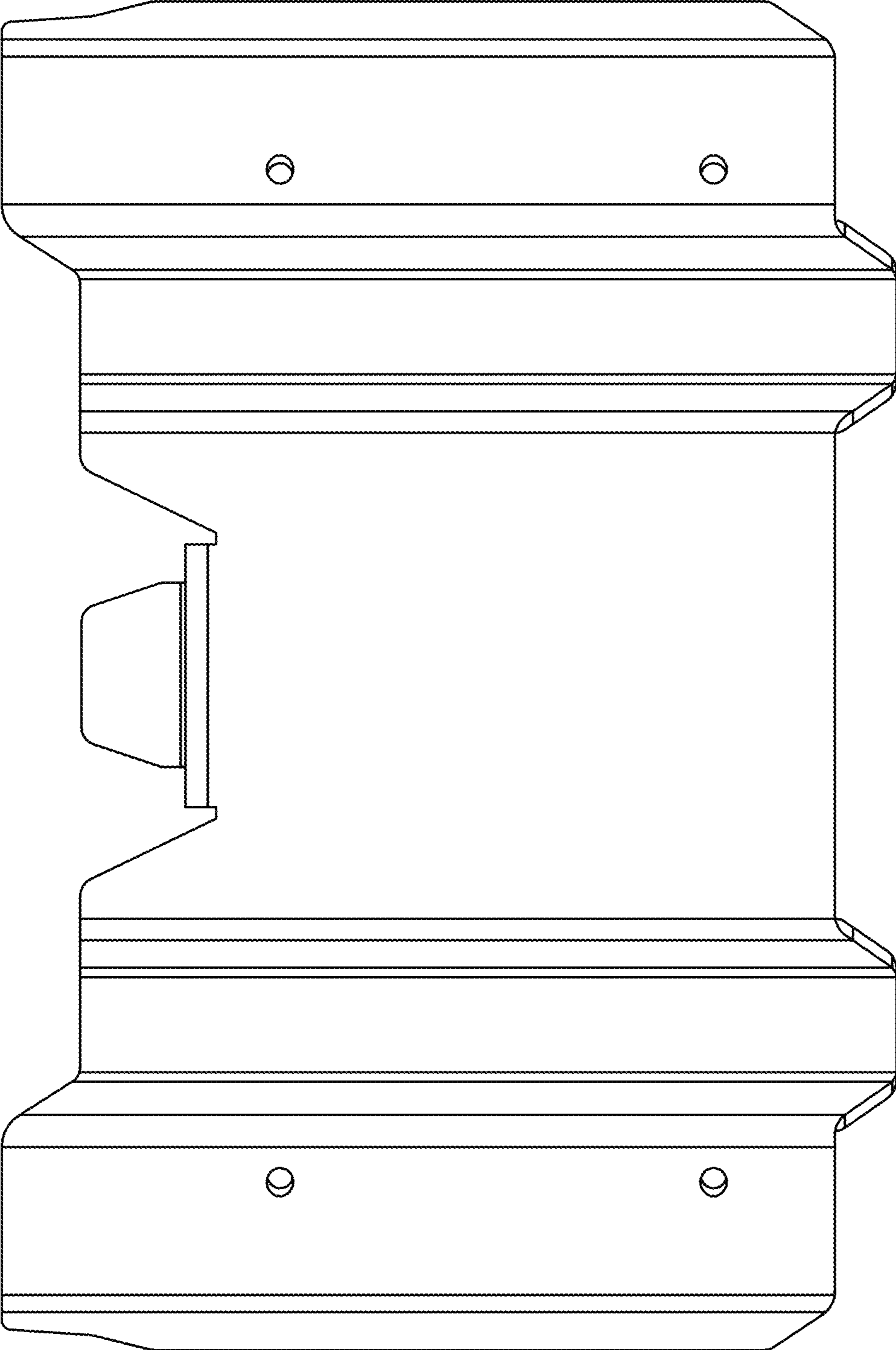

FIG. 2

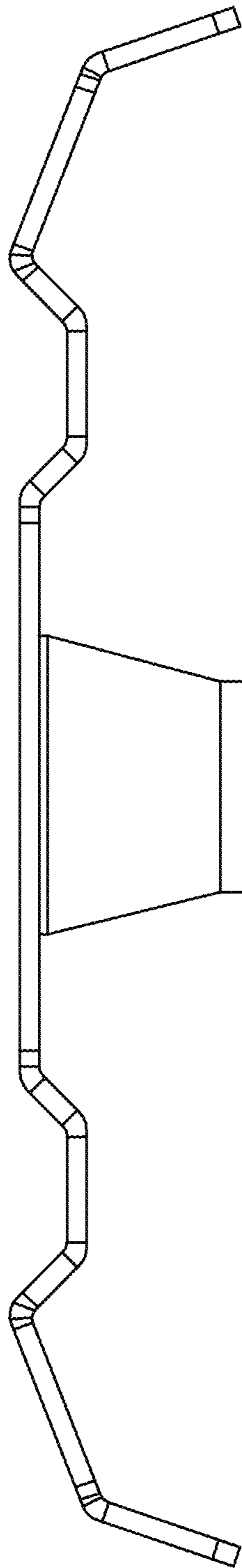

FIG. 3