

US00D739283S

(12) **United States Design Patent**
Kagan

(10) **Patent No.:** **US D739,283 S**
(45) **Date of Patent:** **** Sep. 22, 2015**

- (54) **ELECTRONIC METER**
- (71) Applicant: **Electro Industries/GaugeTech,**
Westbury, NY (US)
- (72) Inventor: **Erran Kagan,** Great Neck, NY (US)
- (73) Assignee: **Electro Industries/Gauge Tech,**
Westbury, NY (US)
- (**) Term: **14 Years**
- (21) Appl. No.: **29/496,764**
- (22) Filed: **Jul. 17, 2014**

3,989,334 A	11/1976	Fortino
D273,574 S	4/1984	Overs
4,609,247 A	9/1986	Annoot
5,014,213 A	5/1991	Edwards et al.
D332,923 S	2/1993	Polydoris et al.
D343,786 S	2/1994	Hines et al.
D348,019 S	6/1994	Kocol et al.
D366,434 S	1/1996	Brown, III et al.
5,581,470 A	12/1996	Pawloski
5,897,661 A	4/1999	Baranovsky et al.
D427,533 S	7/2000	Cowan et al.
D429,655 S	8/2000	Cowan et al.
D435,471 S	12/2000	Simbeck et al.
6,183,274 B1	2/2001	Allum
D439,535 S	3/2001	Cowan et al.
D443,541 S	6/2001	Hancock et al.
D455,066 S	4/2002	Kolinen
D458,863 S	6/2002	Harding et al.
D459,259 S	6/2002	Harding et al.
6,476,595 B1	11/2002	Heuell et al.
6,476,729 B1	11/2002	Liu
6,513,091 B1	1/2003	Blackmon et al.
6,654,842 B1	11/2003	Park
6,745,138 B2	6/2004	Przydatek et al.
D525,893 S	8/2006	Kagan et al.
D526,920 S	8/2006	Kagan et al.
D545,181 S	6/2007	Kagan et al.
7,271,996 B2	9/2007	Kagan et al.
7,417,419 B2	8/2008	Tate
D615,895 S	5/2010	Beattie
7,868,782 B2	1/2011	Ehrke et al.
D642,083 S	7/2011	Blanc et al.
D653,572 S	2/2012	Ohtani et al.
8,176,174 B2	5/2012	Kagan
D666,933 S	9/2012	Hoffman et al.
8,310,403 B2	11/2012	Nahar
8,325,057 B2	12/2012	Salter
D682,720 S	5/2013	Kagan et al.
D682,721 S	5/2013	Kagan et al.
8,587,949 B2	11/2013	Banhegyesi et al.
8,947,246 B2*	2/2015	Aiken 340/635
2001/0027500 A1	10/2001	Matsunaga
2002/0162014 A1	10/2002	Przydatek et al.
2003/0175025 A1	9/2003	Watanabe et al.
2004/0138786 A1	7/2004	Blackett et al.
2004/0193329 A1	9/2004	Ransom et al.
2005/0273281 A1	12/2005	Wall et al.
2006/0070416 A1	4/2006	Teratani
2007/0067119 A1	3/2007	Loewen et al.

Related U.S. Application Data

- (63) Continuation-in-part of application No. 29/449,582, filed on Mar. 15, 2013, now Pat. No. Des. 712,289, which is a continuation of application No. 13/834,737, filed on Mar. 15, 2013, which is a continuation-in-part of application No. 12/628,636, filed on Dec. 1, 2009.
- (51) **LOC (10) Cl.** **10-04**
- (52) **U.S. Cl.**
USPC **D10/100; D10/103**
- (58) **Field of Classification Search**
USPC D10/99, 100, 103; 324/74, 142;
340/870.02, 870.05; 361/736, 668;
702/61
CPC G01R 22/065; G01R 22/06; G01R 21/133;
G01D 4/002; H05K 7/1424; Y02B 90/246;
Y02B 70/3266; Y02B 90/241; Y04S 20/32;
Y04S 20/242; Y04S 20/46
See application file for complete search history.

(56) **References Cited**

U.S. PATENT DOCUMENTS

D56,045 S	8/1920	White
D76,149 S	2/1924	Olsen
1,705,301 A	3/1929	Miller
D187,740 S	4/1960	Littlejohn
D199,808 S	12/1964	Gazzam, III
D201,100 S	5/1965	Little et al.
D241,006 S	8/1976	Wallace

OTHER PUBLICATIONS

BE1-951 Multifunction Protection System, Basler Electric, Sep. 2012 pp. 1-12.

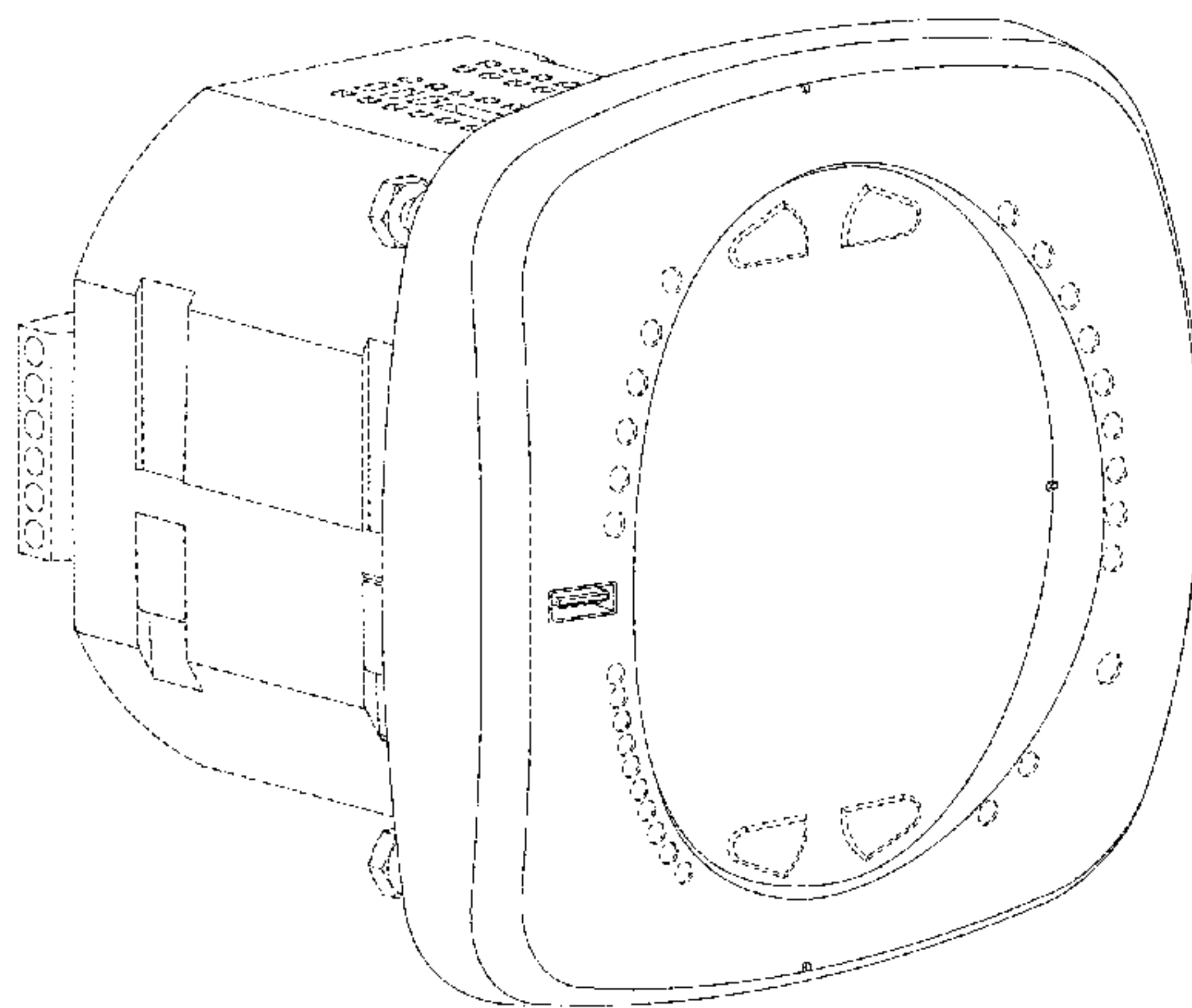

Nexus 1262/1272 High Performance Utility Billing Meters With Communication & Advanced Power Quality, Electro Industries/Gaugetech, Jun. 21, 2012 pp. 1-12.

Jemstar High Accuracy Revenue Meter for Generation, Transmission, and Industrial Power Measurement, Ametek Power Instruments, 2012, pp. 1-2.

Jemstar Retrofit for Generation, Transmission, and Industrial Power Measurement, Ametek Power Instruments, 2007, pp. 1-2.

Mark-V EMS60 Intelligent Energy Meter, Advanced High-Accuracy Meter With Integrated Data Telemetry Solutions and Power Quality Monitoring, Transdata Energy Metering and Automation, 2010, pp. 1-2.

Nexus 1262/1272 Switchboard Meter Quick Start, Electro Industries-Gaugetech, Aug. 31, 2012, pp. 1-4.

Powerlogic ION8650, Schneider Electric, 2011, pp. 1-12.

IEEE Standard Common Format for Transient Data Exchange, Oct. 15, 1999, IEEE, pp. 1-55.

Power Quality Standards Coordinating Committee, IEEE P1159. 31D9 Draft: Recommended Practice for the Transfer of Power Quality Data, Aug. 1, 2002, IEEE Standards Activities Department, pp. 1-129.

Anderson, D., USB System Architecture, Nov. 2000, Addison-Wesley Professional, 9th Printing, pp. 22-23.

* cited by examiner

Primary Examiner — Antoine D Davis

(74) *Attorney, Agent, or Firm* — Gerald E. Hespos; Michael J. Porco; Matthew T. Hespos

(57)

CLAIM

The ornamental design for an electronic meter, as shown and described.

DESCRIPTION

FIG. 1 is a front, top, left perspective view of an electronic meter according to a first embodiment of my new design;

FIG. 2 is a rear, top, left perspective view thereof;

FIG. 3 is a front elevational view thereof;

FIG. 4 is a rear elevational view thereof;

FIG. 5 is a left side elevational view thereof;

FIG. 6 is a right side elevational view thereof;

FIG. 7 is a top plan view thereof;

FIG. 8 is a bottom plan view thereof;

FIG. 9 is a front, top, left perspective view of an electronic meter according to a second embodiment of my new design;

FIG. 10 is a front elevational view of FIG. 9;

FIG. 11 is a front, top, left perspective view of an electronic meter according to a third embodiment of my new design;

FIG. 12 is a front elevational view of FIG. 11;

FIG. 13 is a front, top, left perspective view of an electronic meter according to a fourth embodiment of my new design;

FIG. 14 is a front elevational view of FIG. 13;

FIG. 15 is a front, top, left perspective view of an electronic meter according to a fifth embodiment of my new design;

FIG. 16 is a front elevational view of FIG. 15;

FIG. 17 is a front, top, left perspective view of an electronic meter according to a sixth embodiment of my new design;

FIG. 18 is a front elevational view of FIG. 17;

FIG. 19 is a front, top, left perspective view of an electronic meter according to a seventh embodiment of my new design;

FIG. 20 is a front elevational view of FIG. 19;

FIG. 21 is a front, top, left perspective view of an electronic meter according to an eighth embodiment of my new design;

FIG. 22 is a front elevational view of FIG. 21;

FIG. 23 is a front, top, left perspective view of an electronic meter according to a ninth embodiment of my new design;

FIG. 24 is a front elevational view of FIG. 23;

FIG. 25 is a front, top, left perspective view of an electronic meter according to a tenth embodiment of my new design;

FIG. 26 is a front elevational view of FIG. 25;

FIG. 27 is a front, top, left perspective view of an electronic meter according to an eleventh embodiment of my new design;

FIG. 28 is a front elevational view of FIG. 27;

FIG. 29 is a front, top, left perspective view of an electronic meter according to a twelfth embodiment of my new design;

FIG. 30 is a front elevational view of FIG. 29;

FIG. 31 is a front, top, left perspective view of an electronic meter according to a thirteenth embodiment of my new design;

FIG. 32 is a front elevational view of FIG. 31;

FIG. 33 is a front, top, left perspective view of an electronic meter according to a fourteenth embodiment of my new design;

FIG. 34 is a front elevational view of FIG. 33;

FIG. 35 is a front, top, left perspective view of an electronic meter according to a fifteenth embodiment of my new design;

FIG. 36 is a front elevational view of FIG. 35;

FIG. 37 is a front, top, left perspective view of an electronic meter according to a sixteenth embodiment of my new design;

FIG. 38 is a front elevational view of FIG. 37;

FIG. 39 is a front, top, left perspective view of an electronic meter according to a seventeenth embodiment of my new design;

FIG. 40 is a front elevational view of FIG. 39;

FIG. 41 is a front, top, left perspective view of an electronic meter according to an eighteenth second embodiment of my new design;

FIG. 42 is a front elevational view of FIG. 41;

FIG. 43 is a front, top, left perspective view of an electronic meter according to a nineteenth embodiment of my new design;

FIG. 44 is a front elevational view of FIG. 43;

FIG. 45 is a front, top, left perspective view of an electronic meter according to a twentieth embodiment of my new design;

FIG. 46 is a front elevational view of FIG. 45;

FIG. 47 is a front, top, left perspective view of an electronic meter according to a twenty-first embodiment of my new design;

FIG. 48 is a front elevational view of FIG. 47;

FIG. 49 is a front, top, left perspective view of an electronic meter according to a twenty-second embodiment of my new design;

FIG. 50 is a front elevational view of FIG. 49;

FIG. 51 is a front, top, left perspective view of an electronic meter according to a twenty-third embodiment of my new design;

FIG. 52 is a front elevational view of FIG. 51;

FIG. 53 is a front, top, left perspective view of an electronic meter according to a twenty-fourth embodiment of my new design; and,

FIG. 54 is a front elevational view of FIG. 53.

The broken line showing of structural features is included for the purpose of illustrating non-claimed subject matter and forms no part of the claimed design.

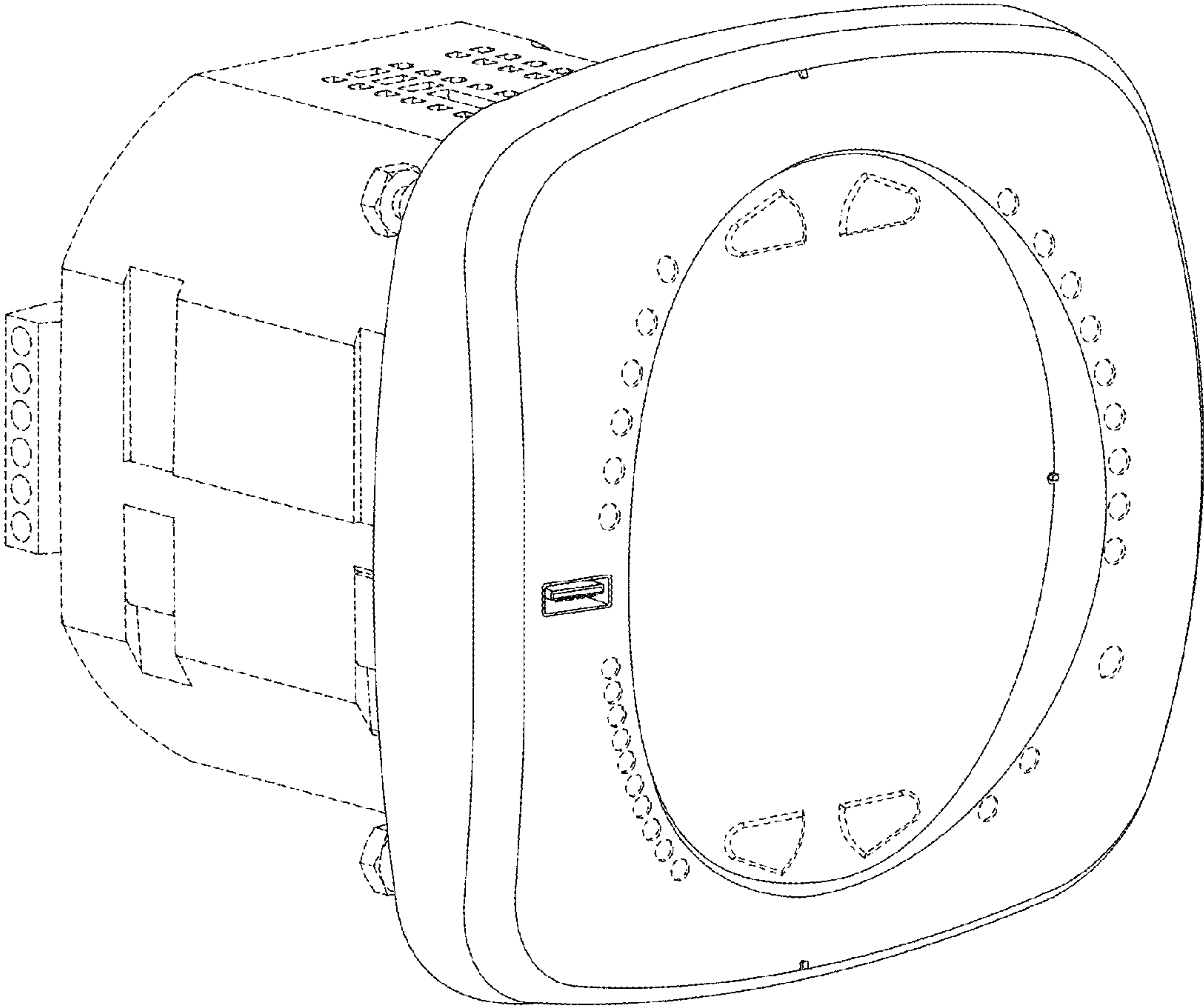

FIG. 1

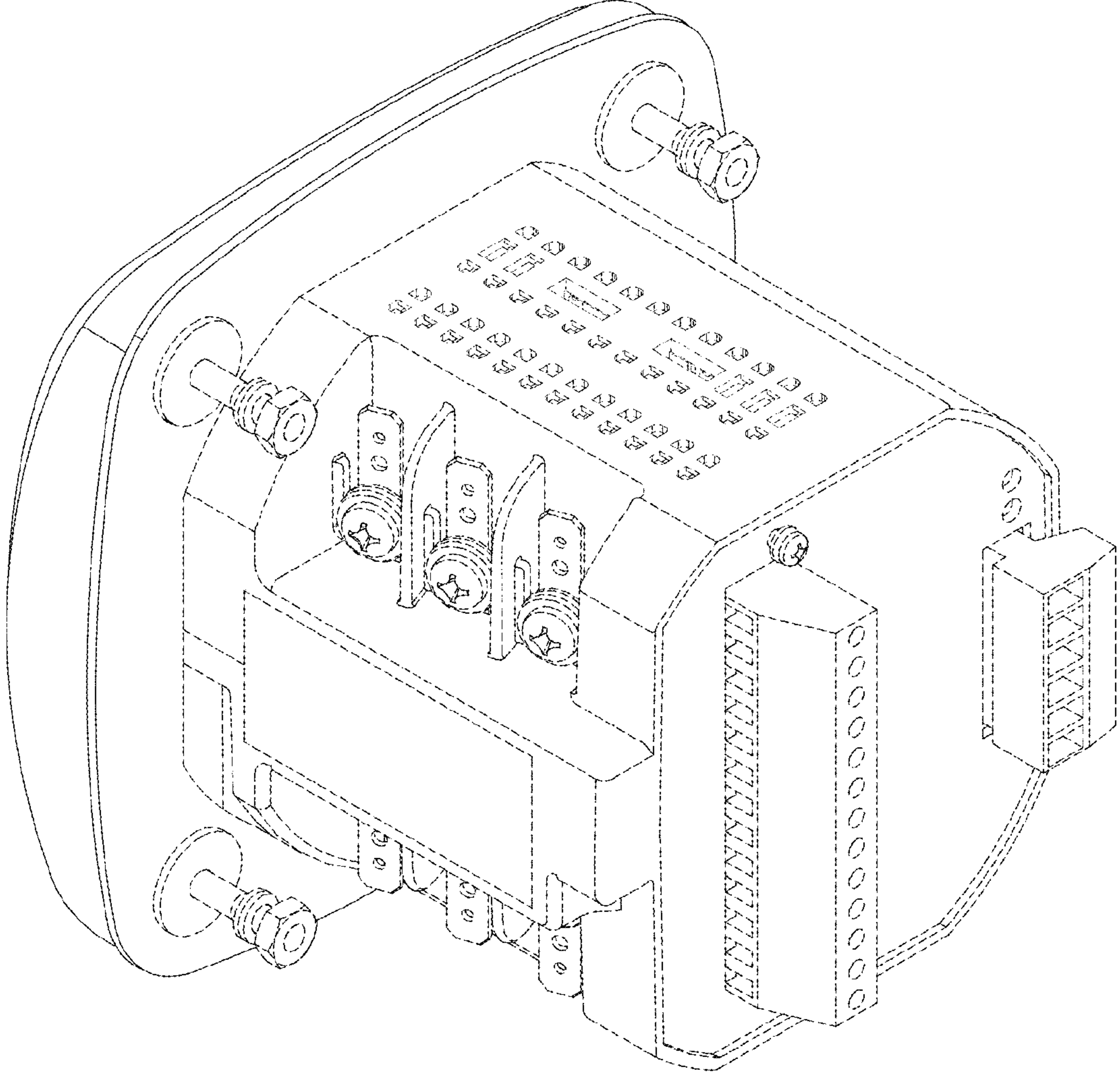

FIG. 2

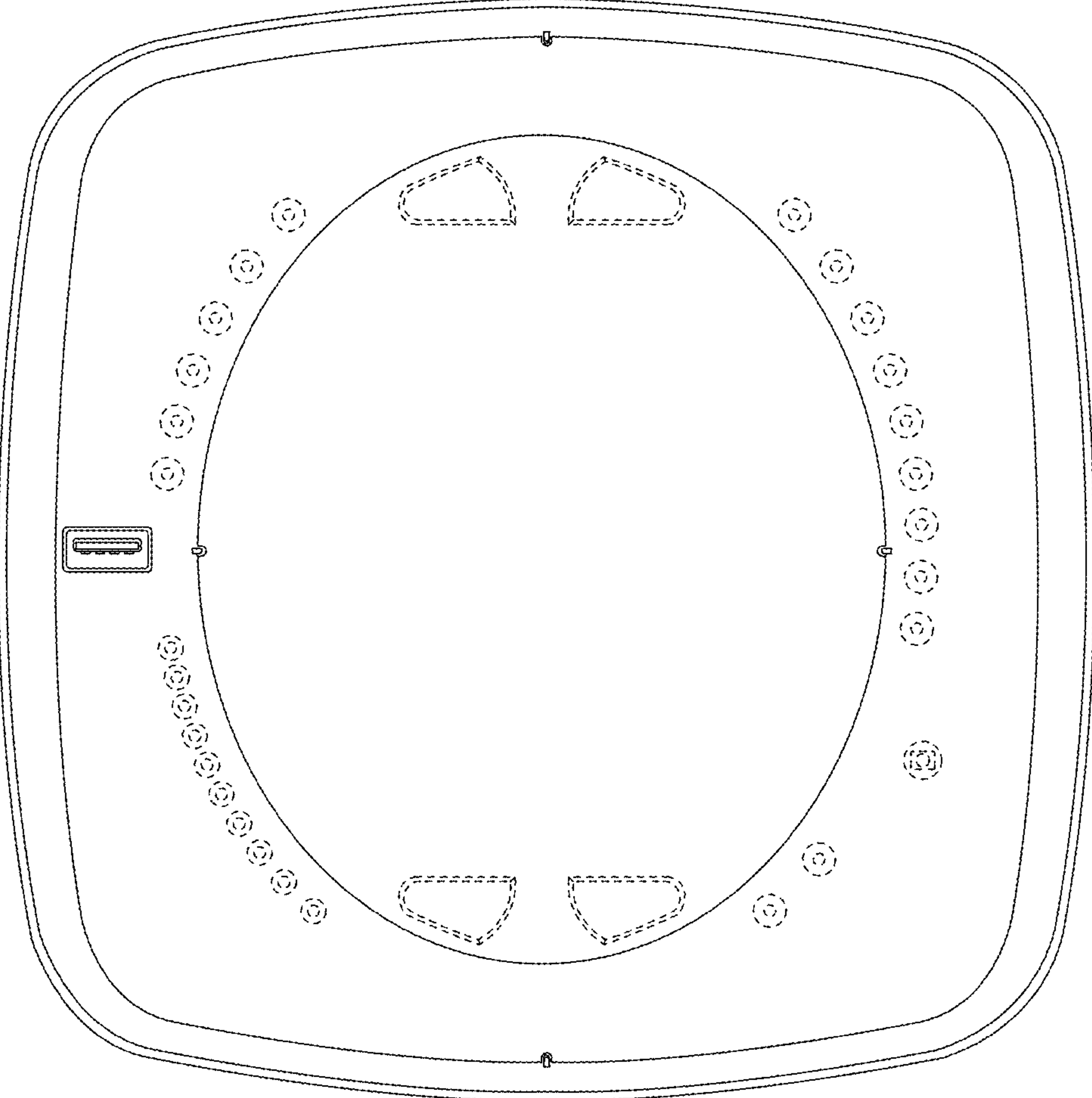

FIG. 3

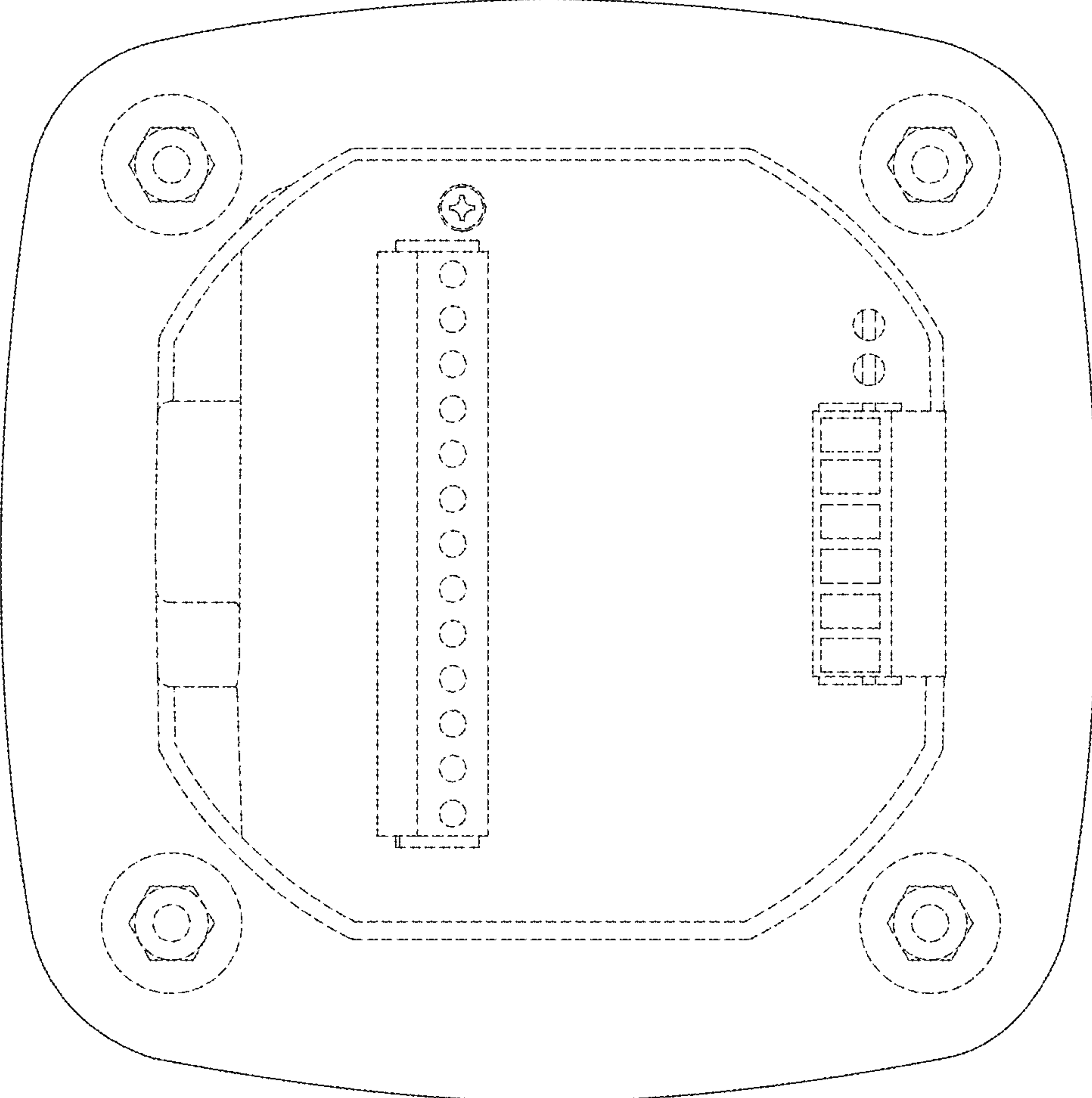

FIG. 4

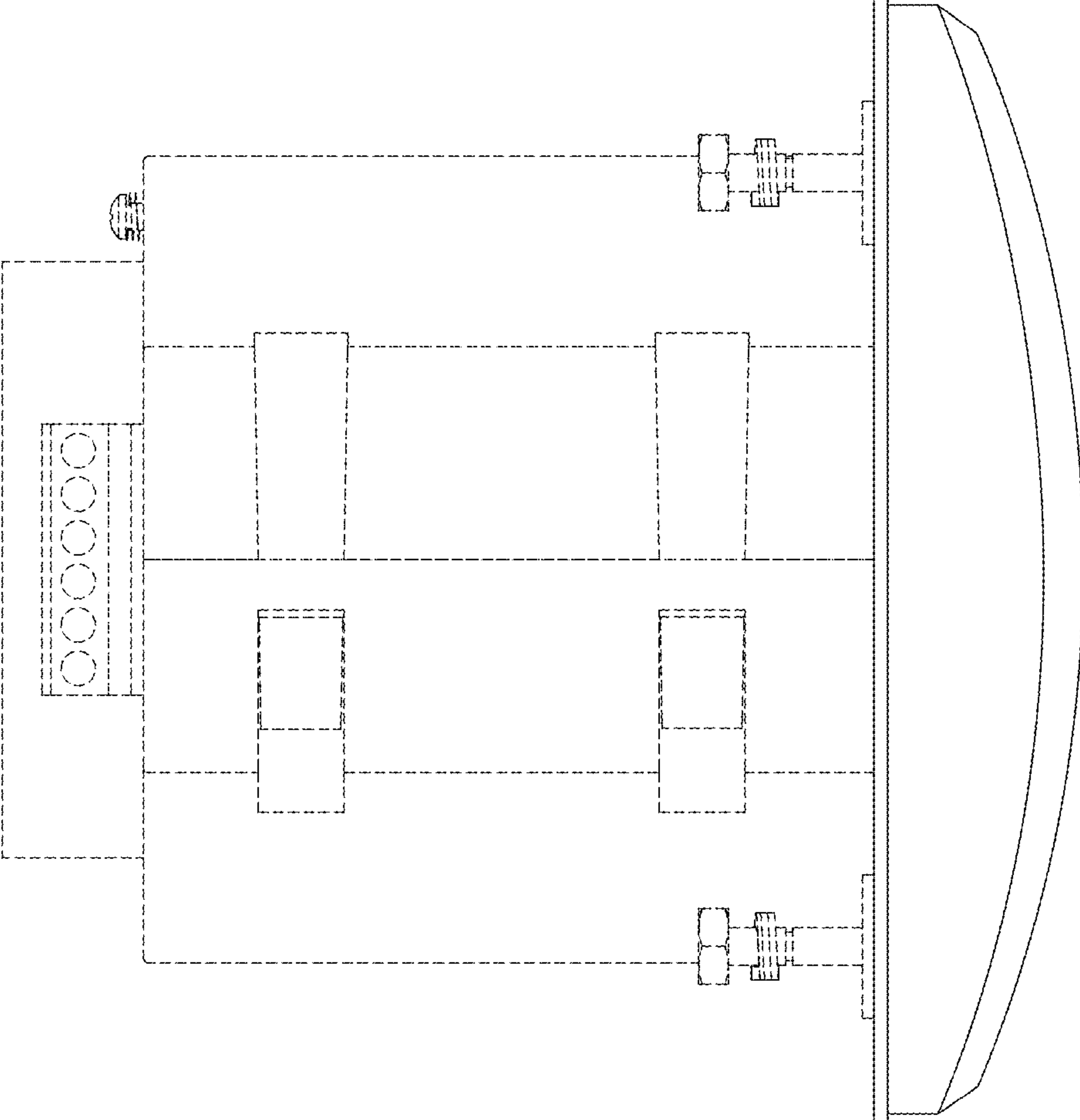

FIG. 5

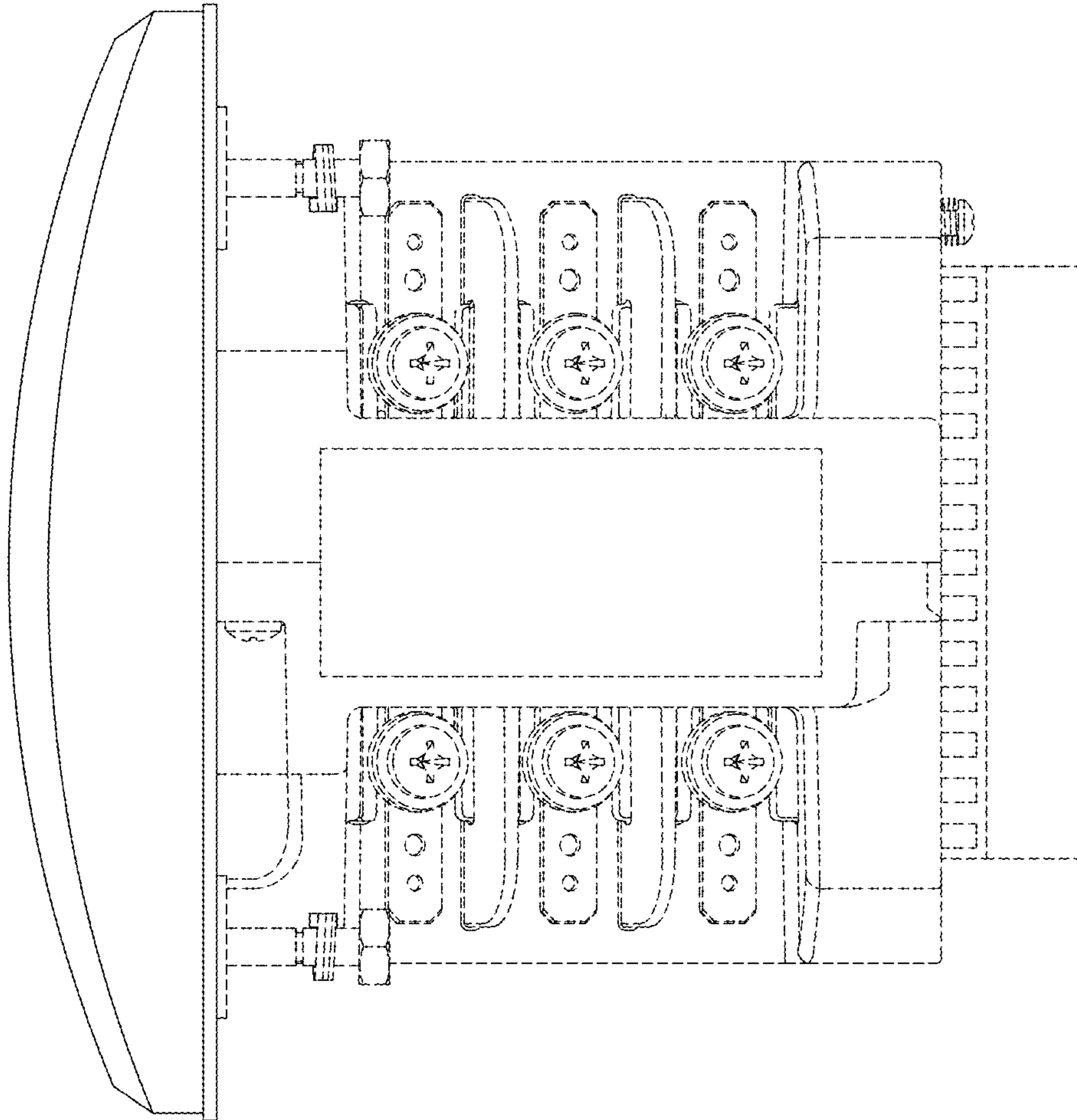

FIG. 6

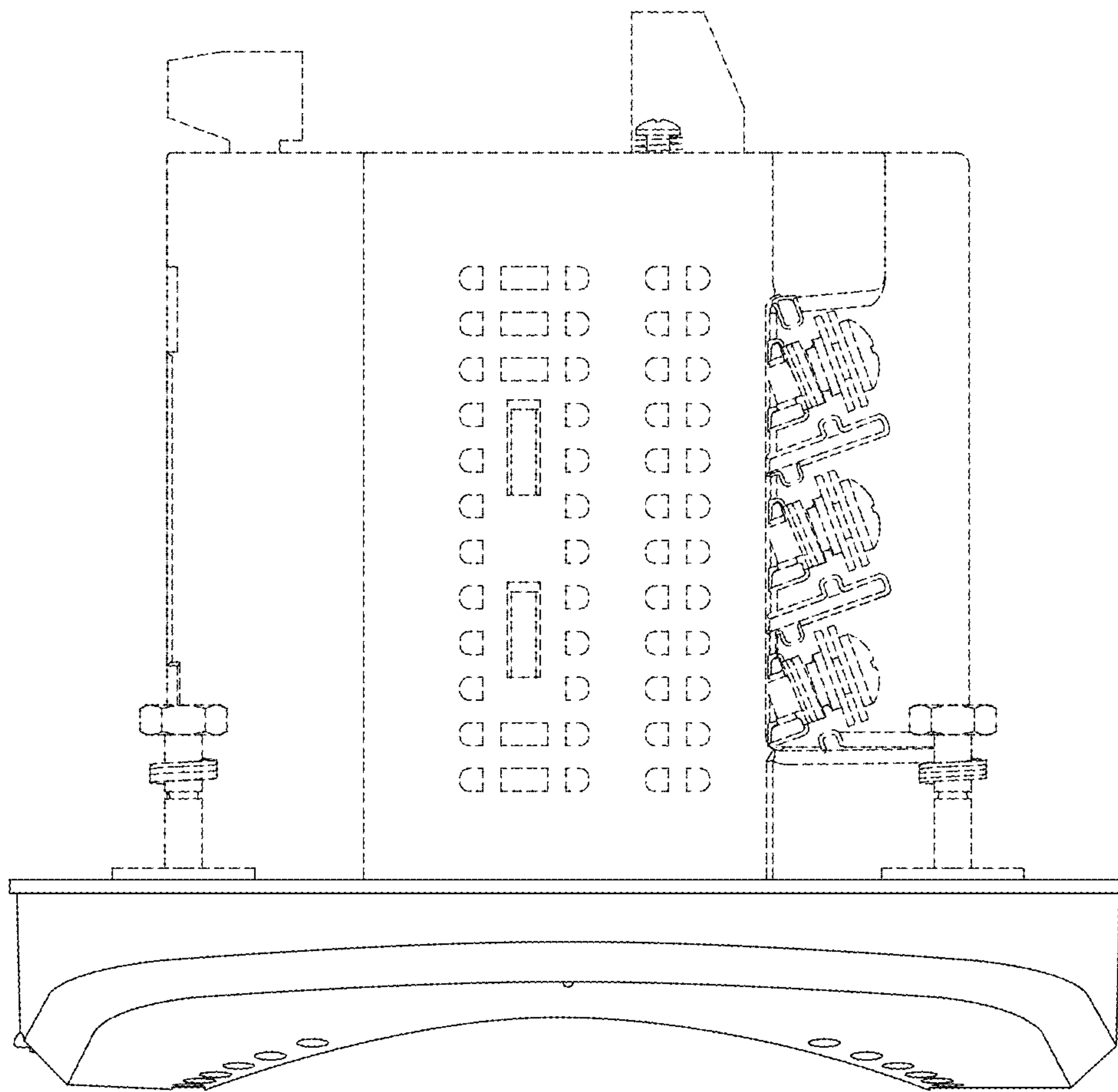

FIG. 7

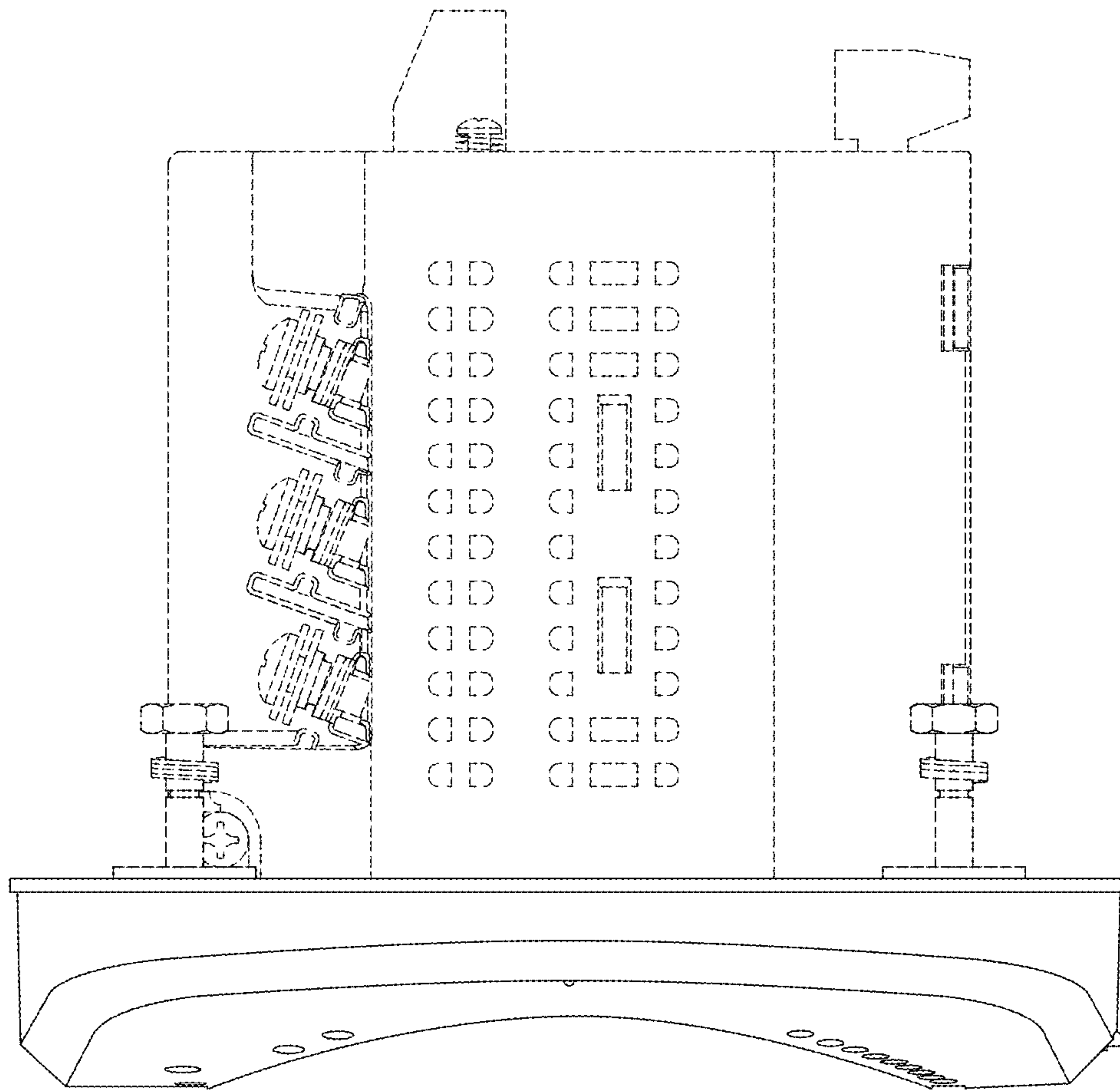

FIG. 8

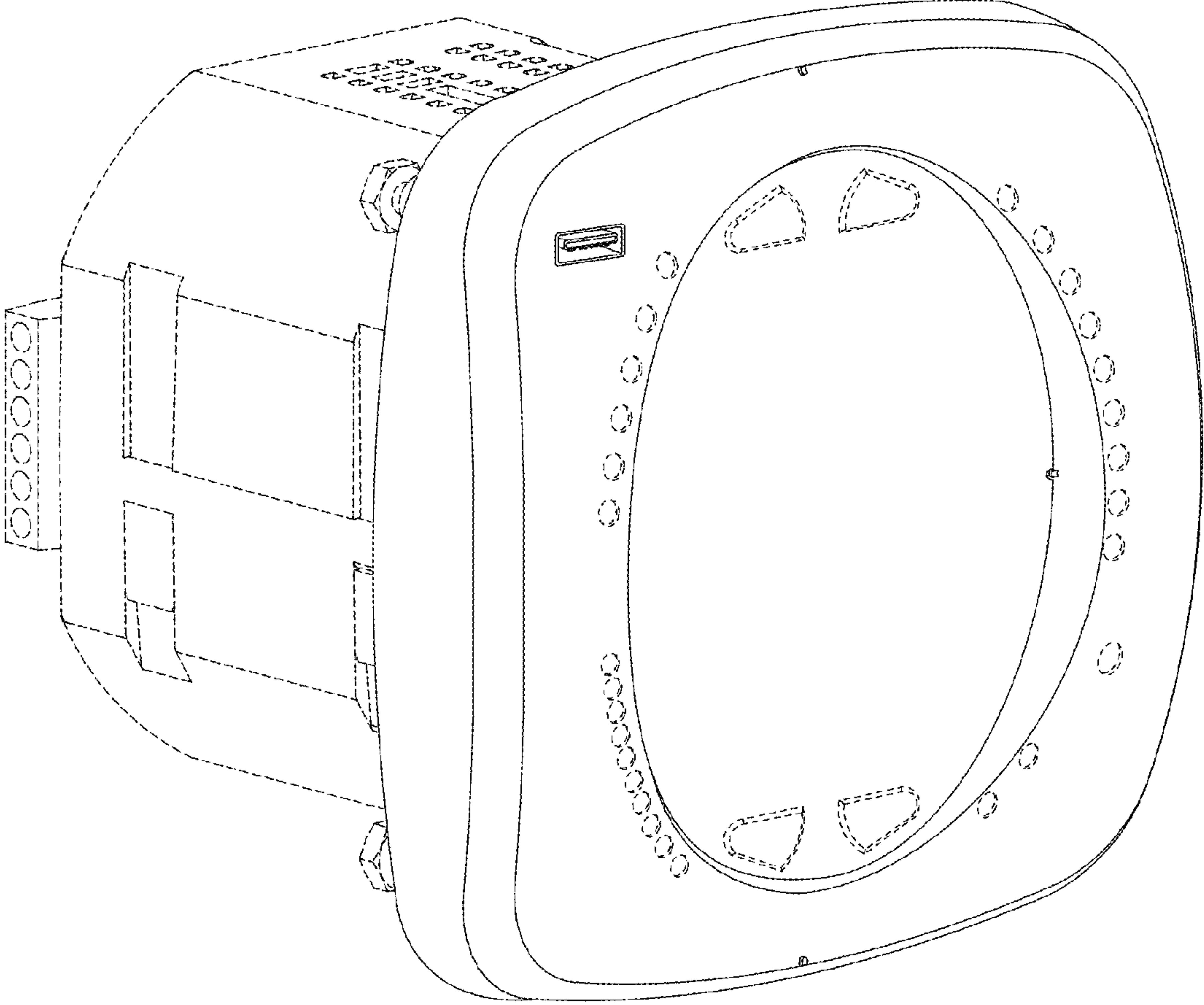

FIG. 9

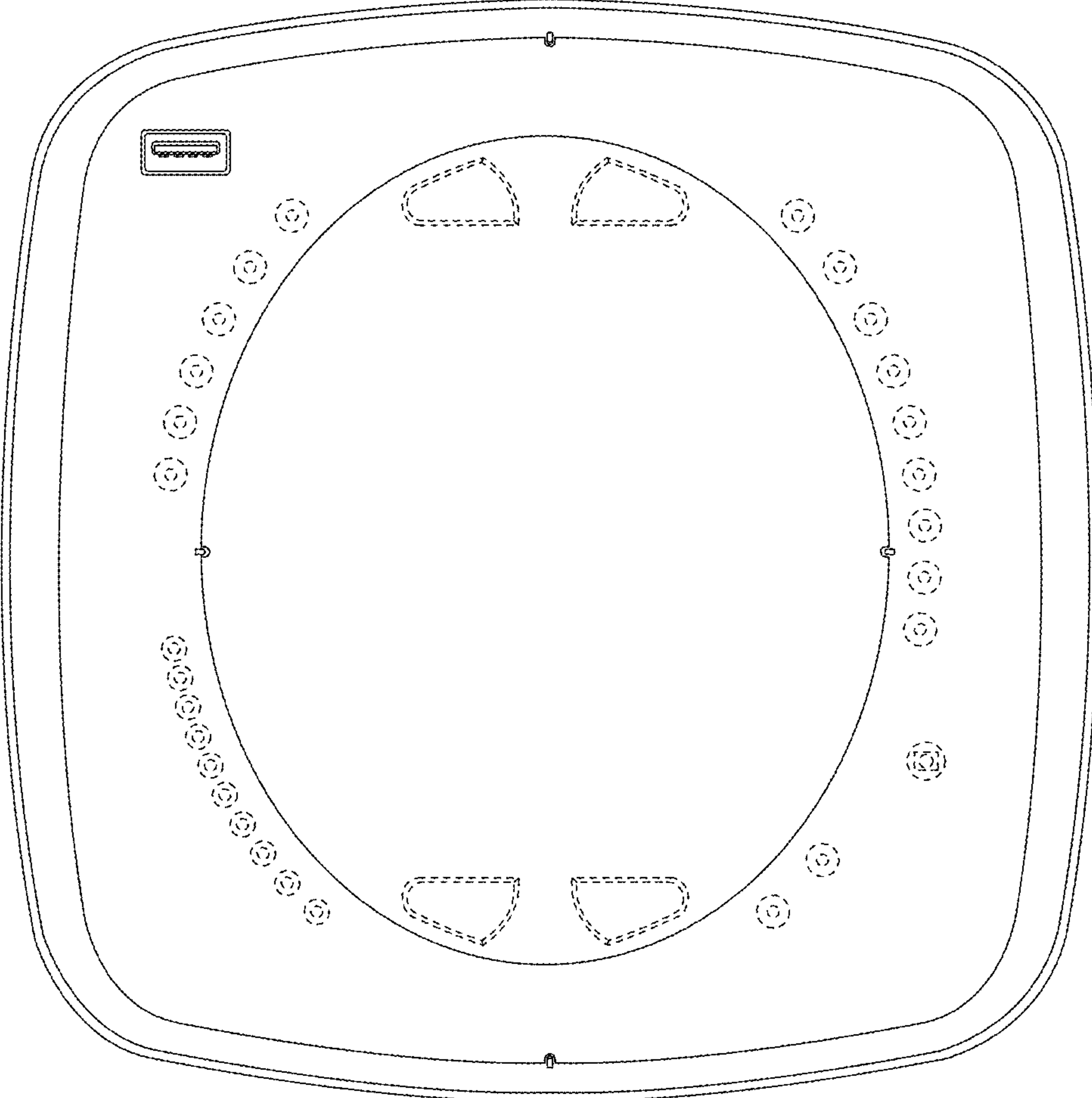

FIG. 10

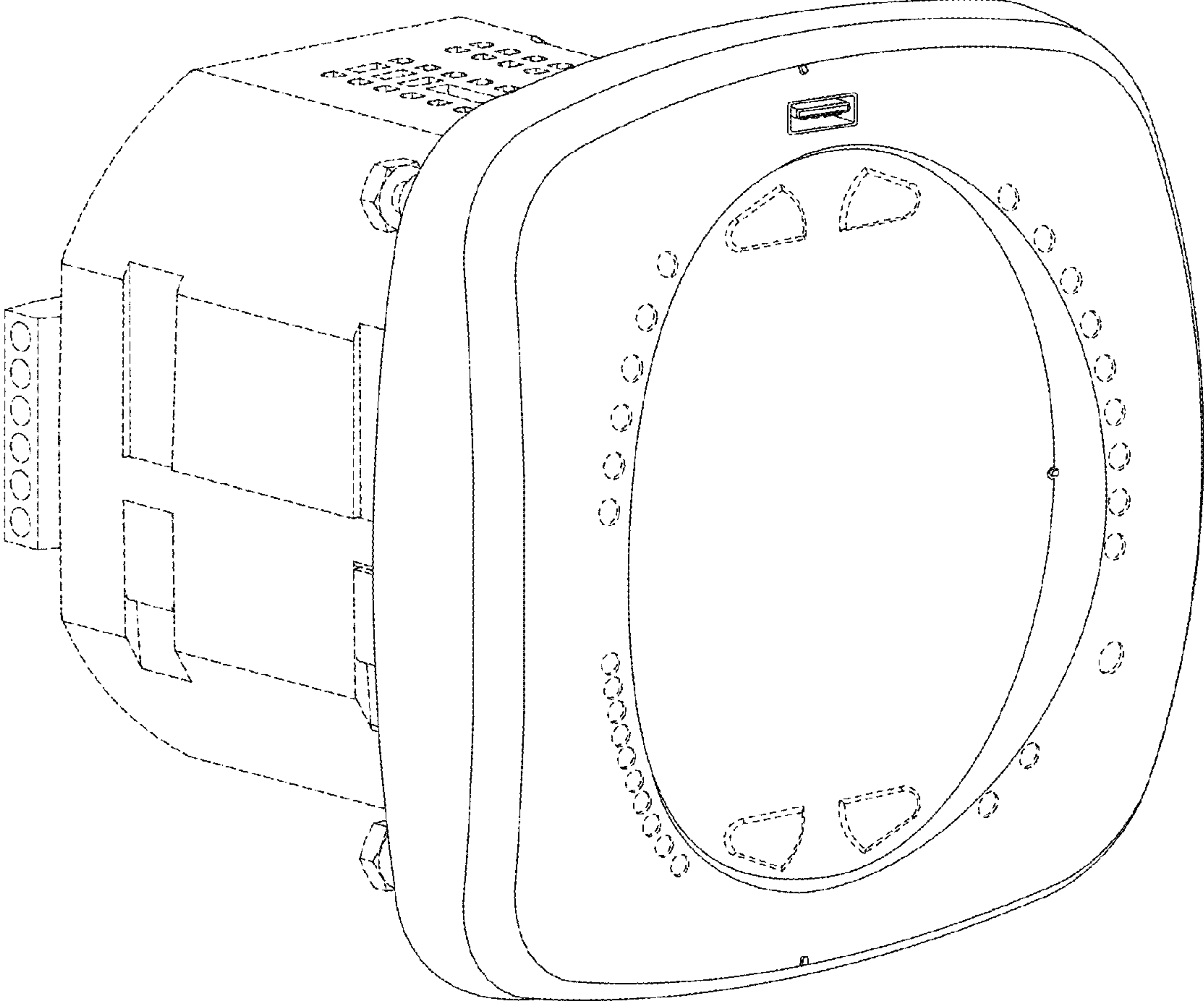

FIG. 11

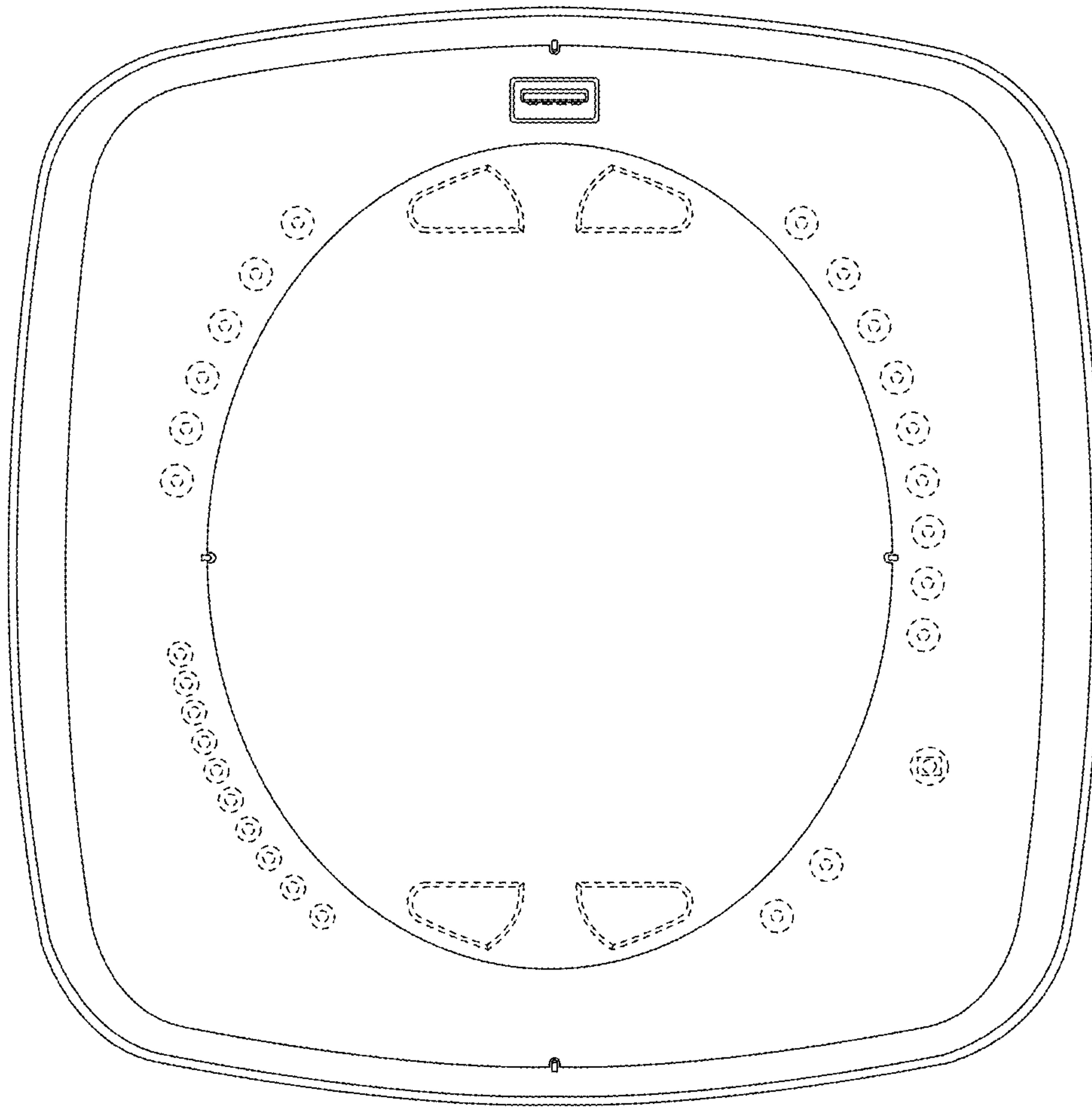

FIG. 12

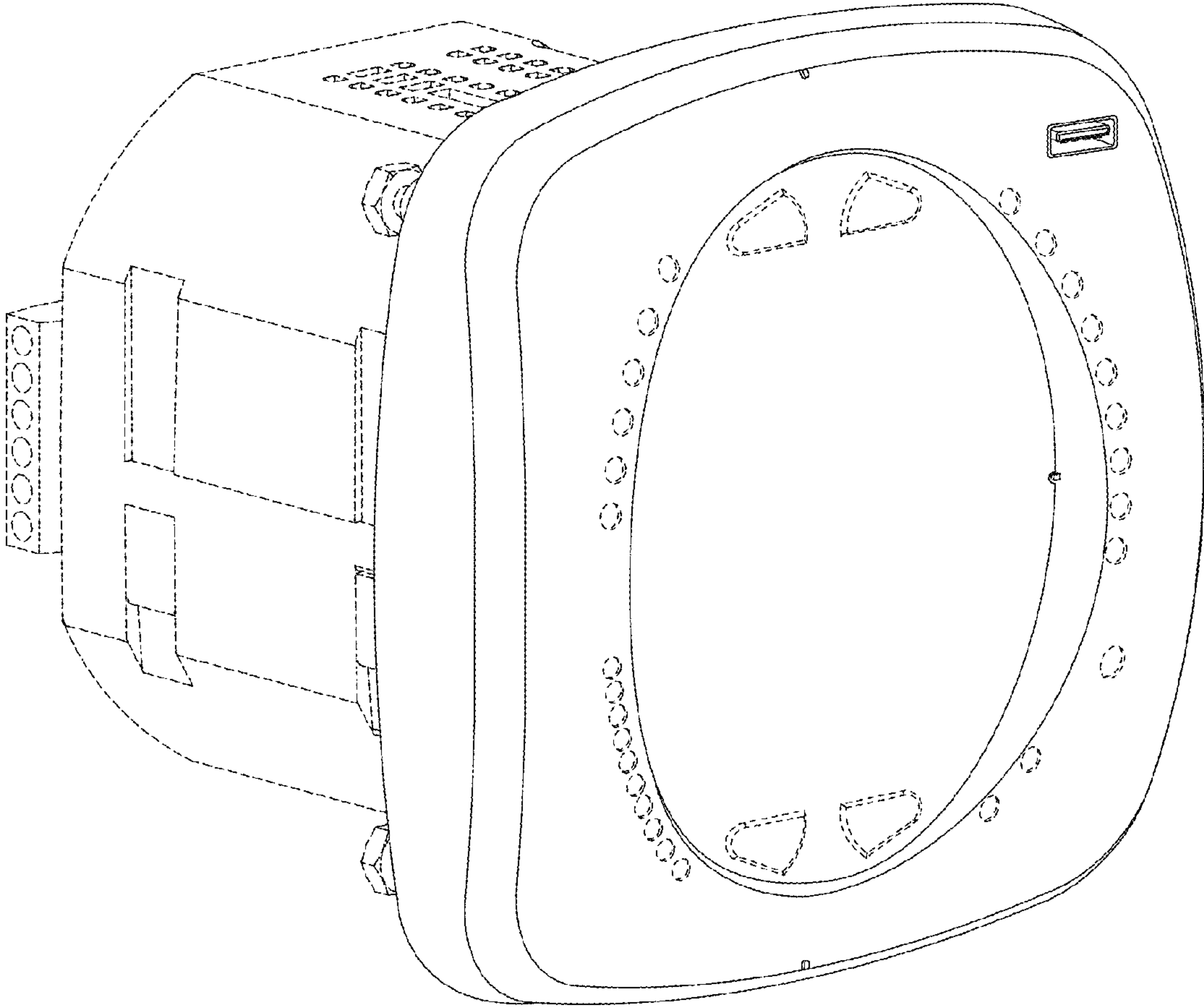

FIG. 13

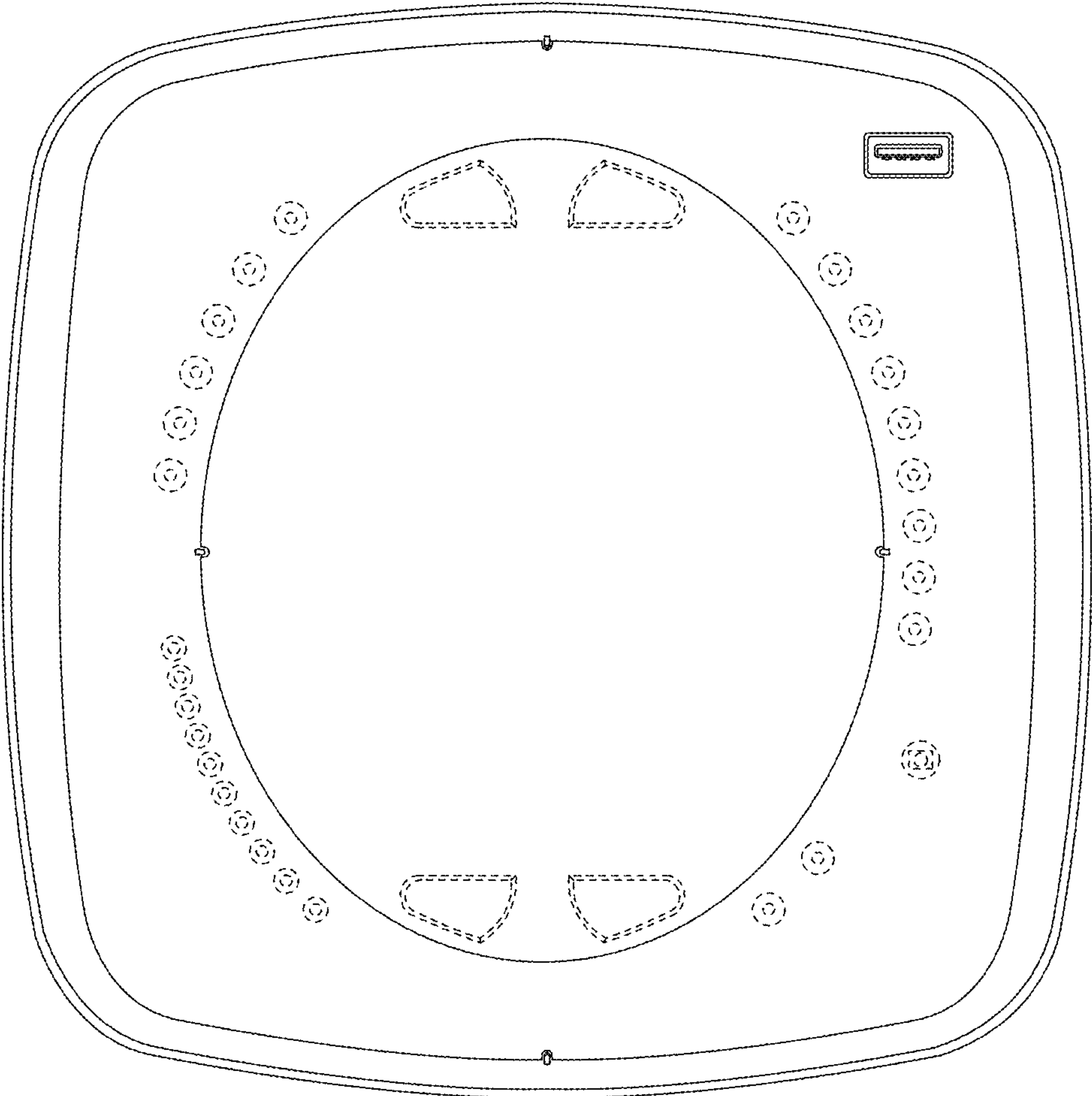

FIG. 14

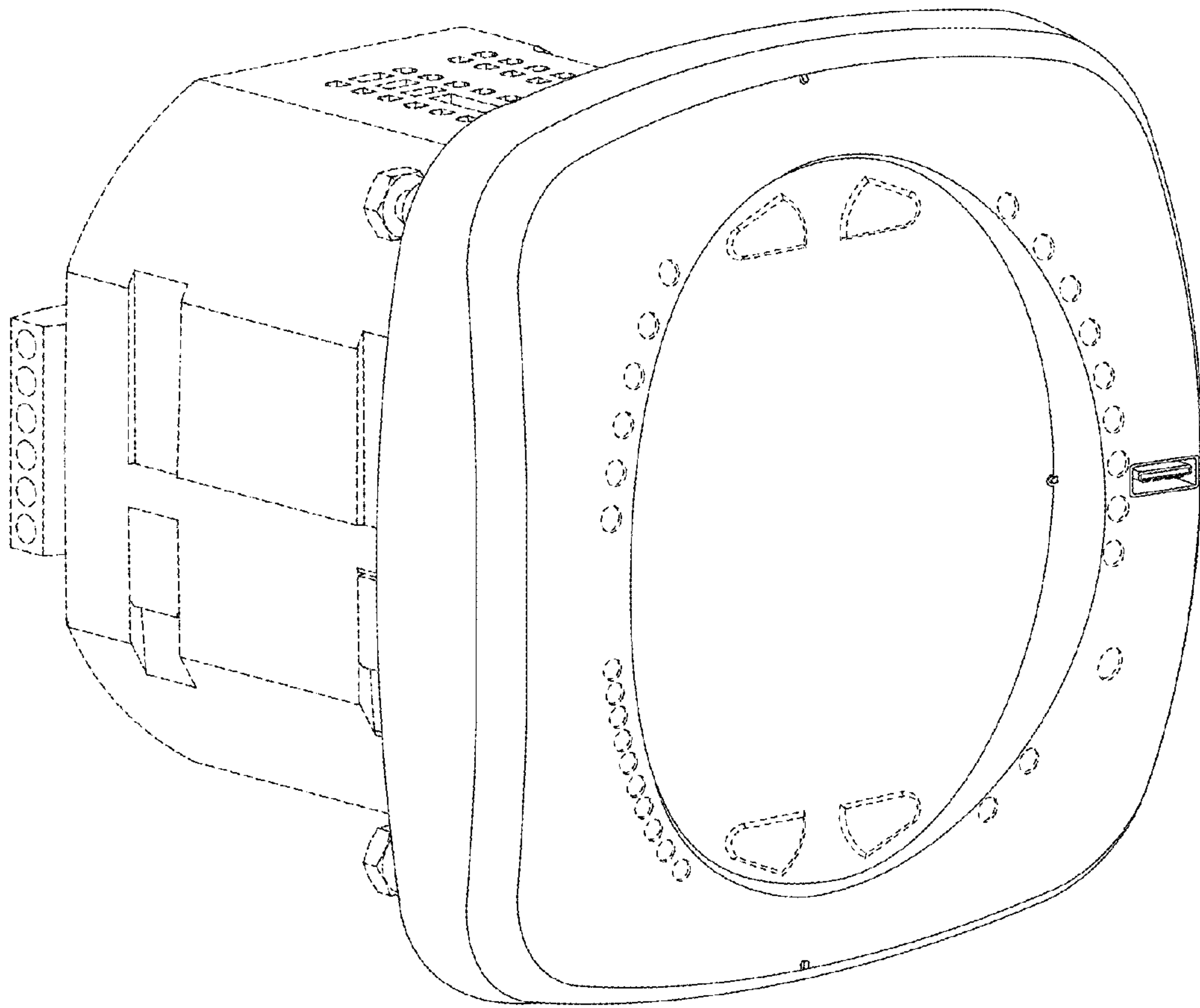

FIG. 15

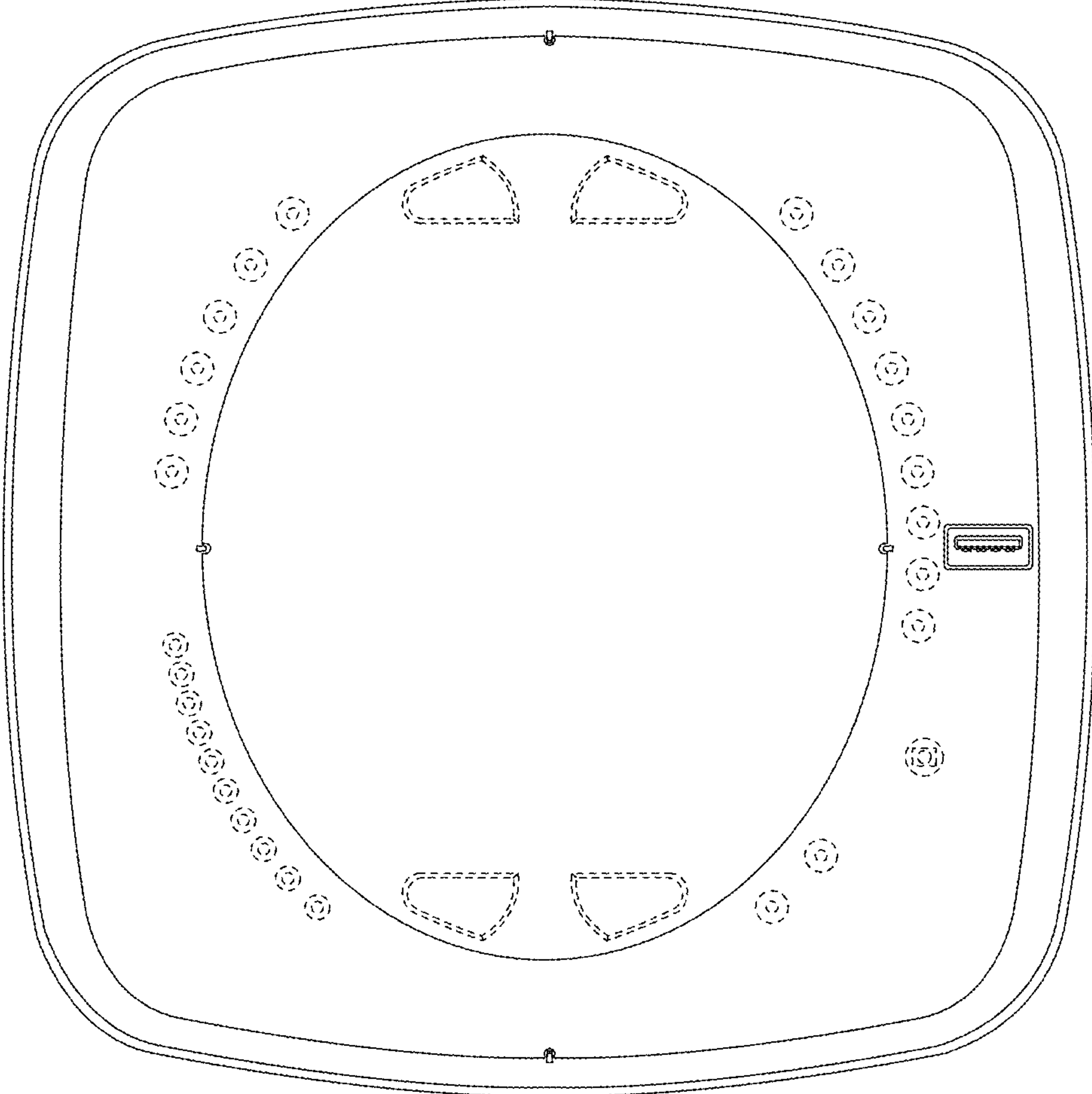

FIG. 16

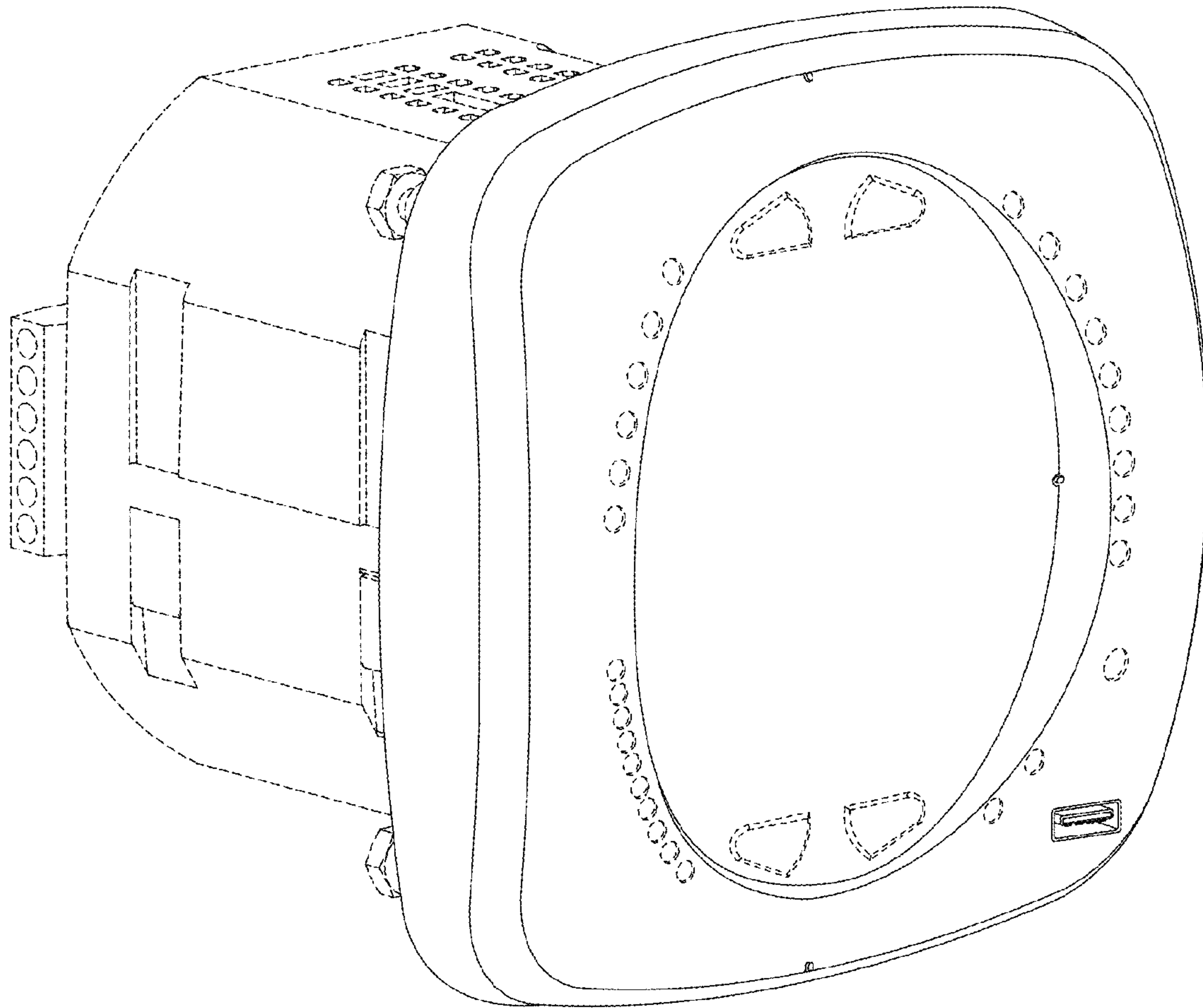

FIG. 17

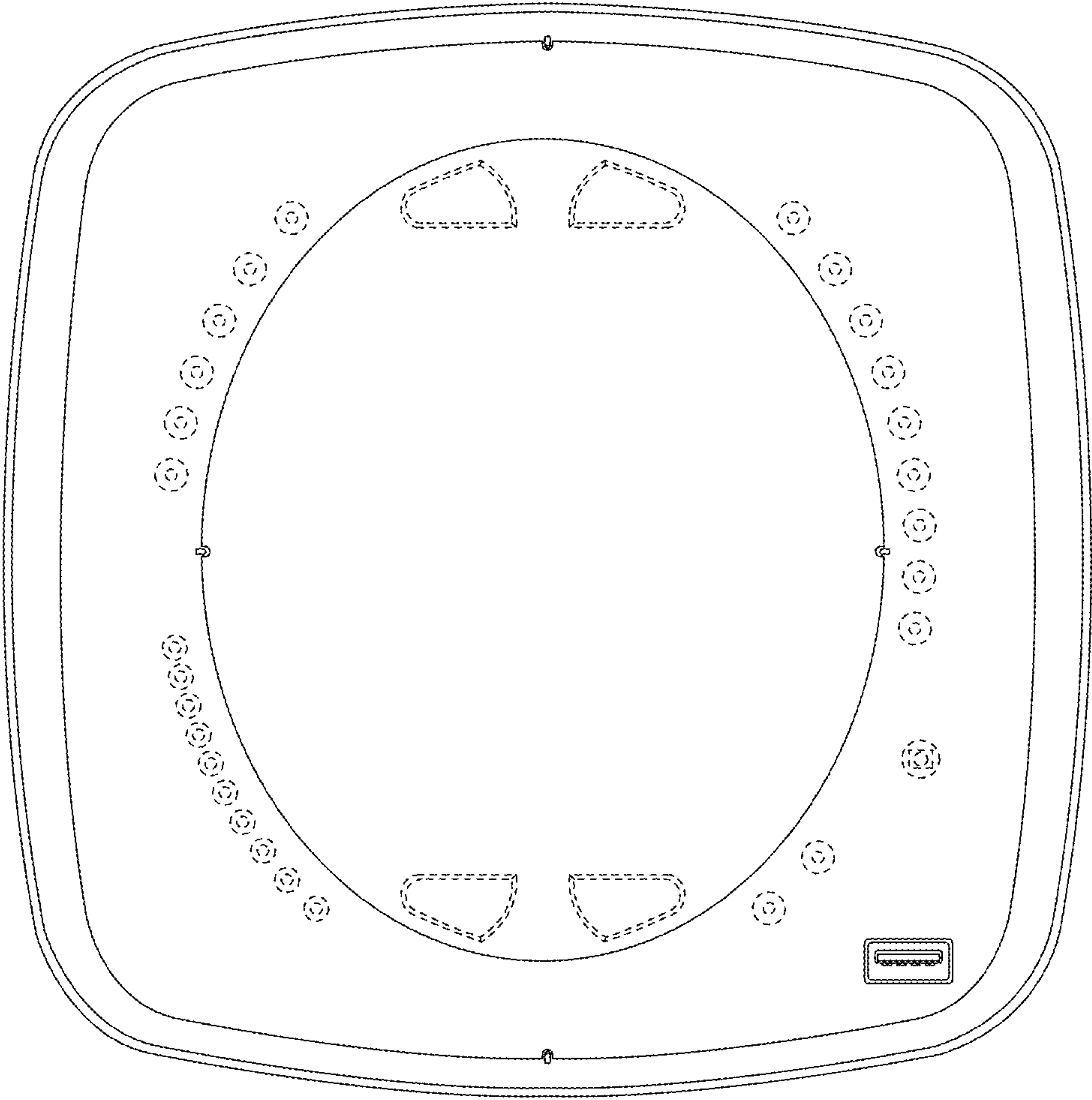

FIG. 18

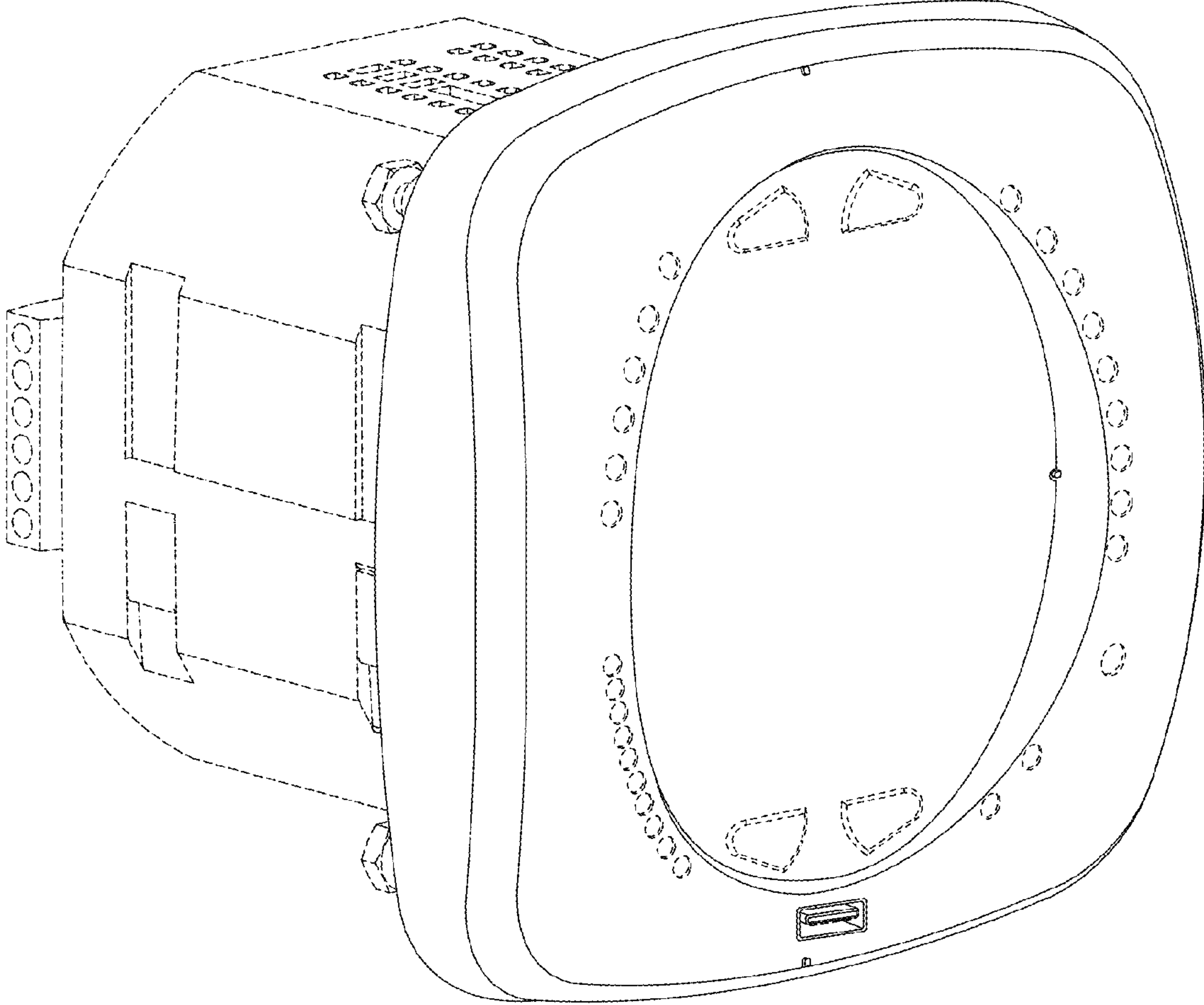

FIG. 19

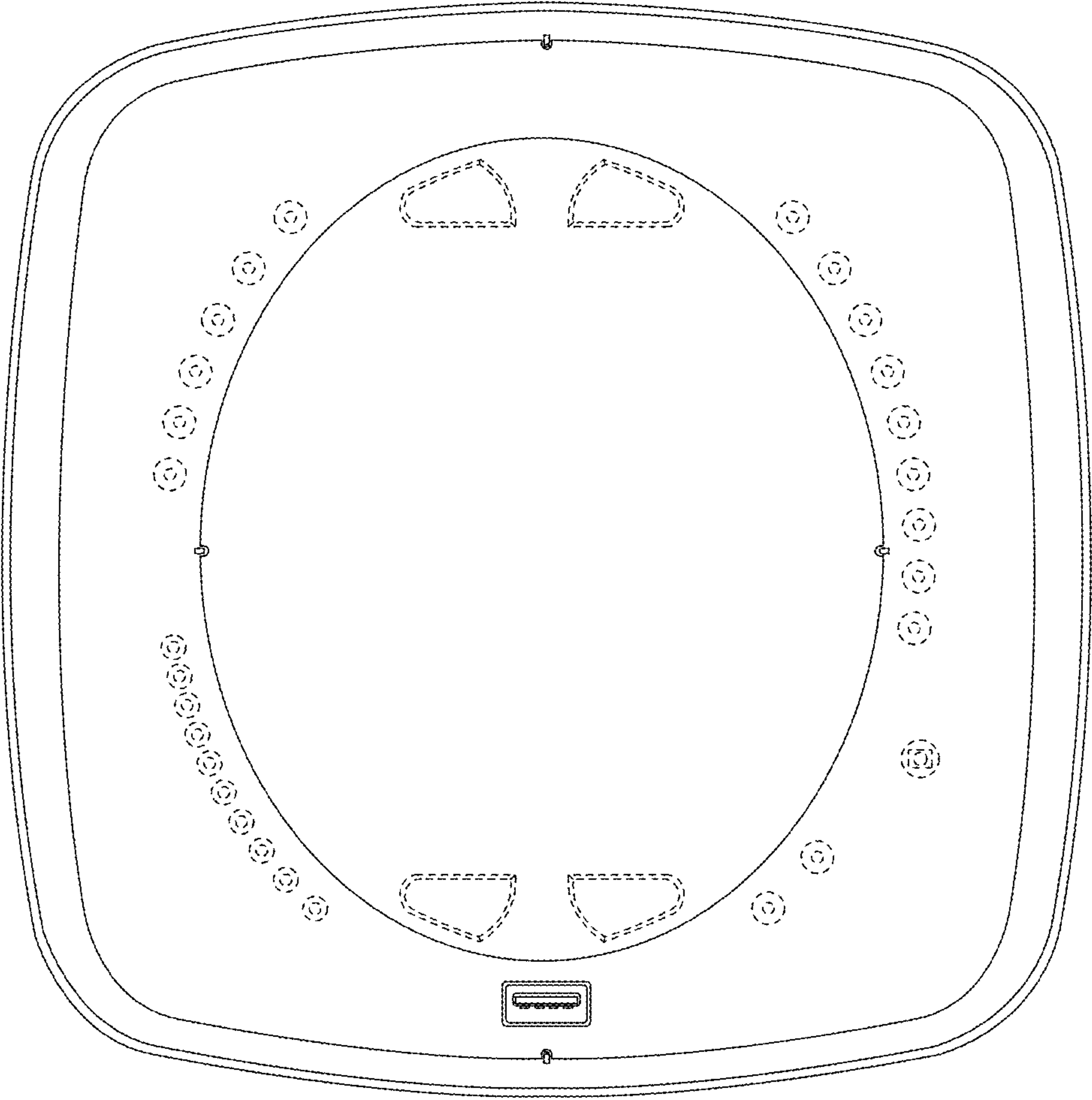

FIG. 20

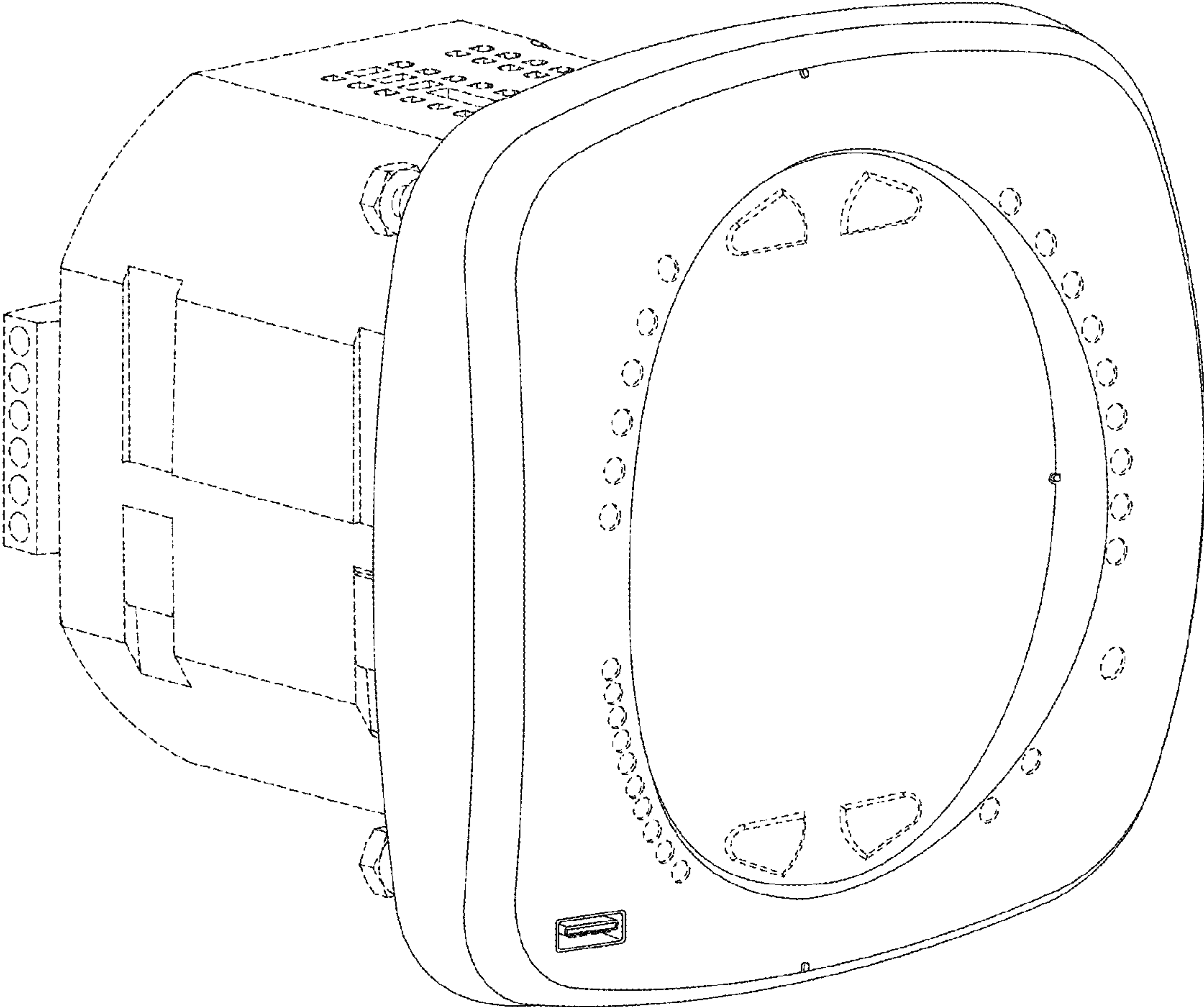

FIG. 21

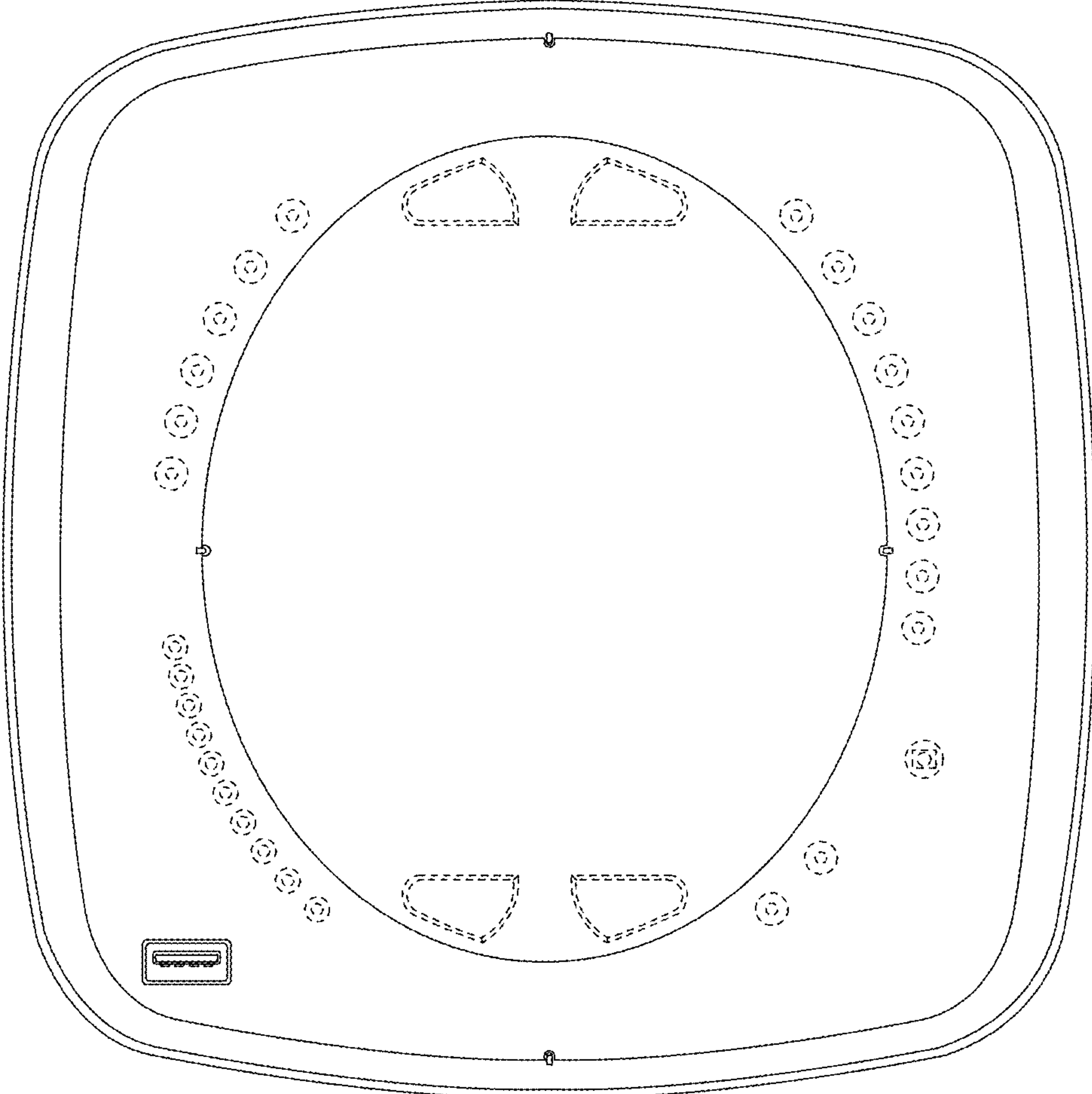

FIG. 22

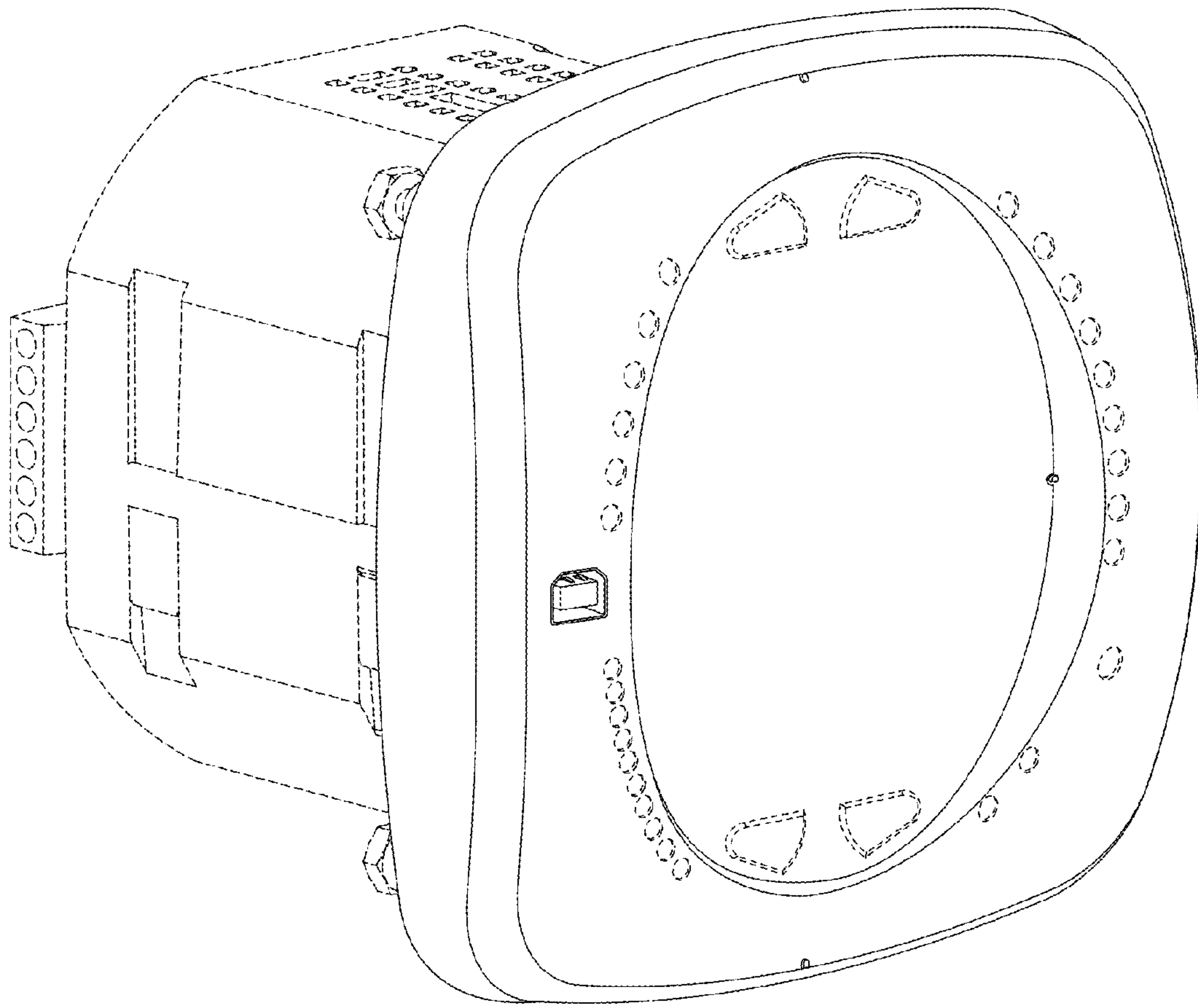

FIG. 23

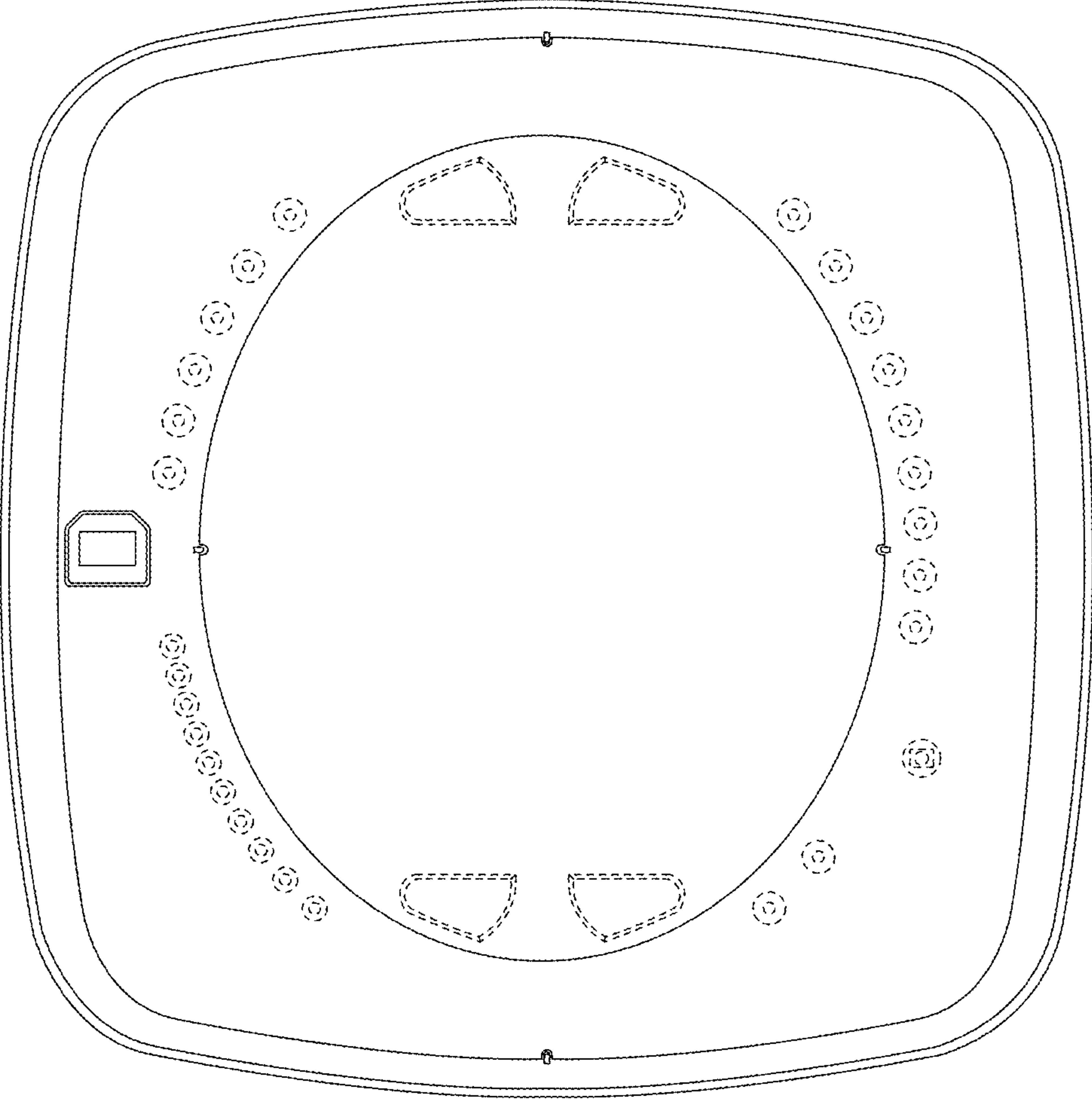

FIG. 24

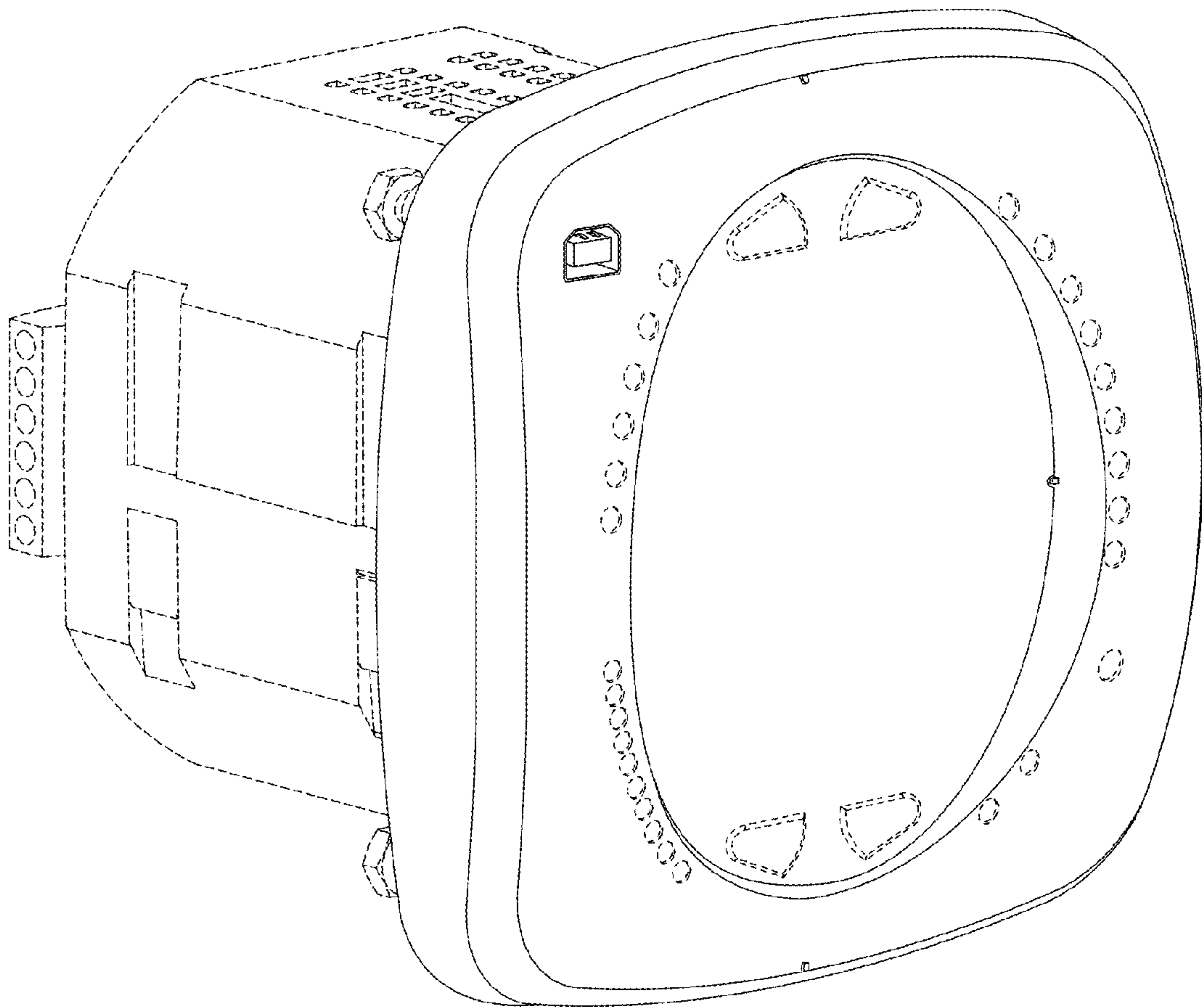

FIG. 25

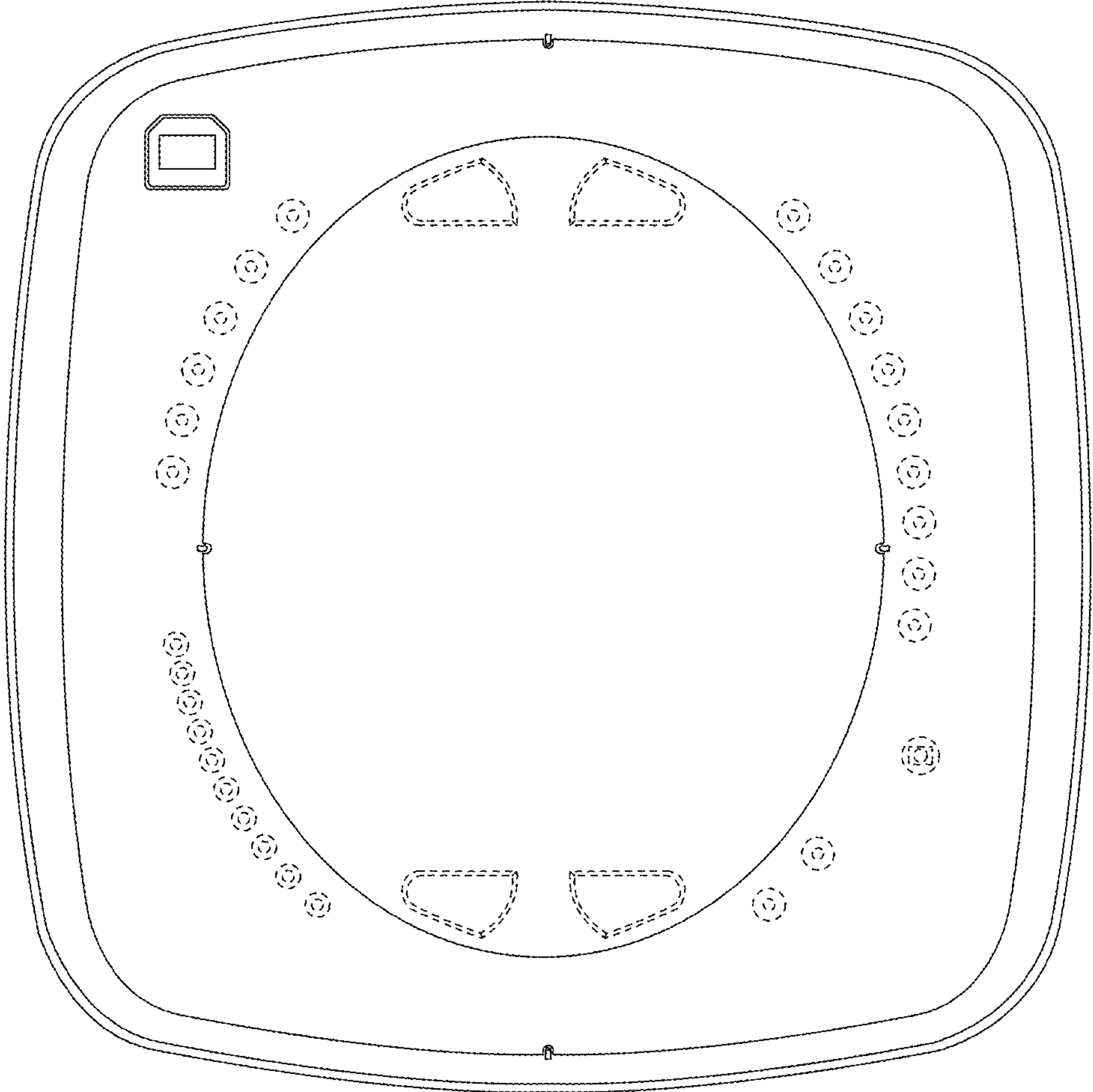

FIG. 26

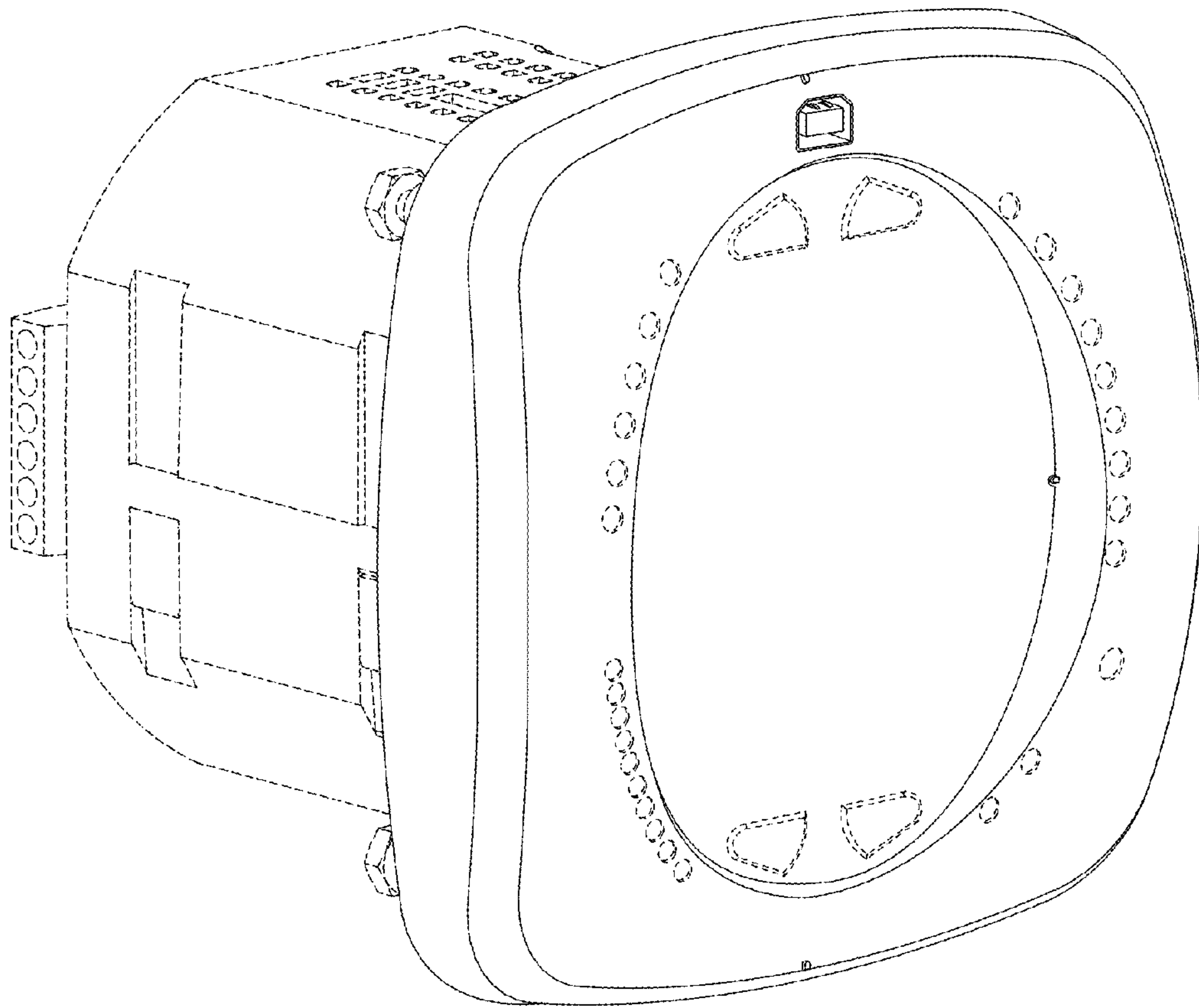

FIG. 27

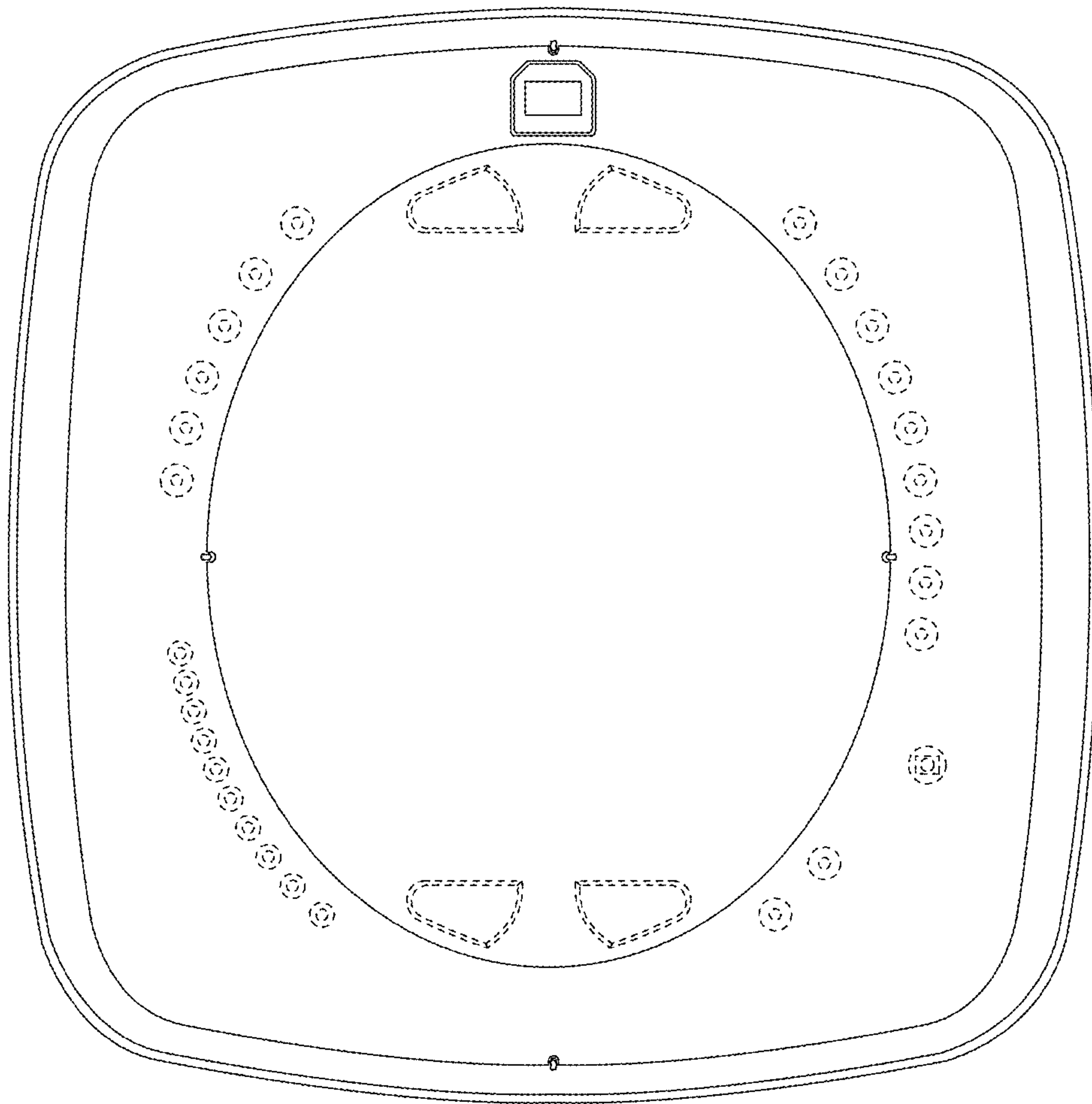

FIG. 28

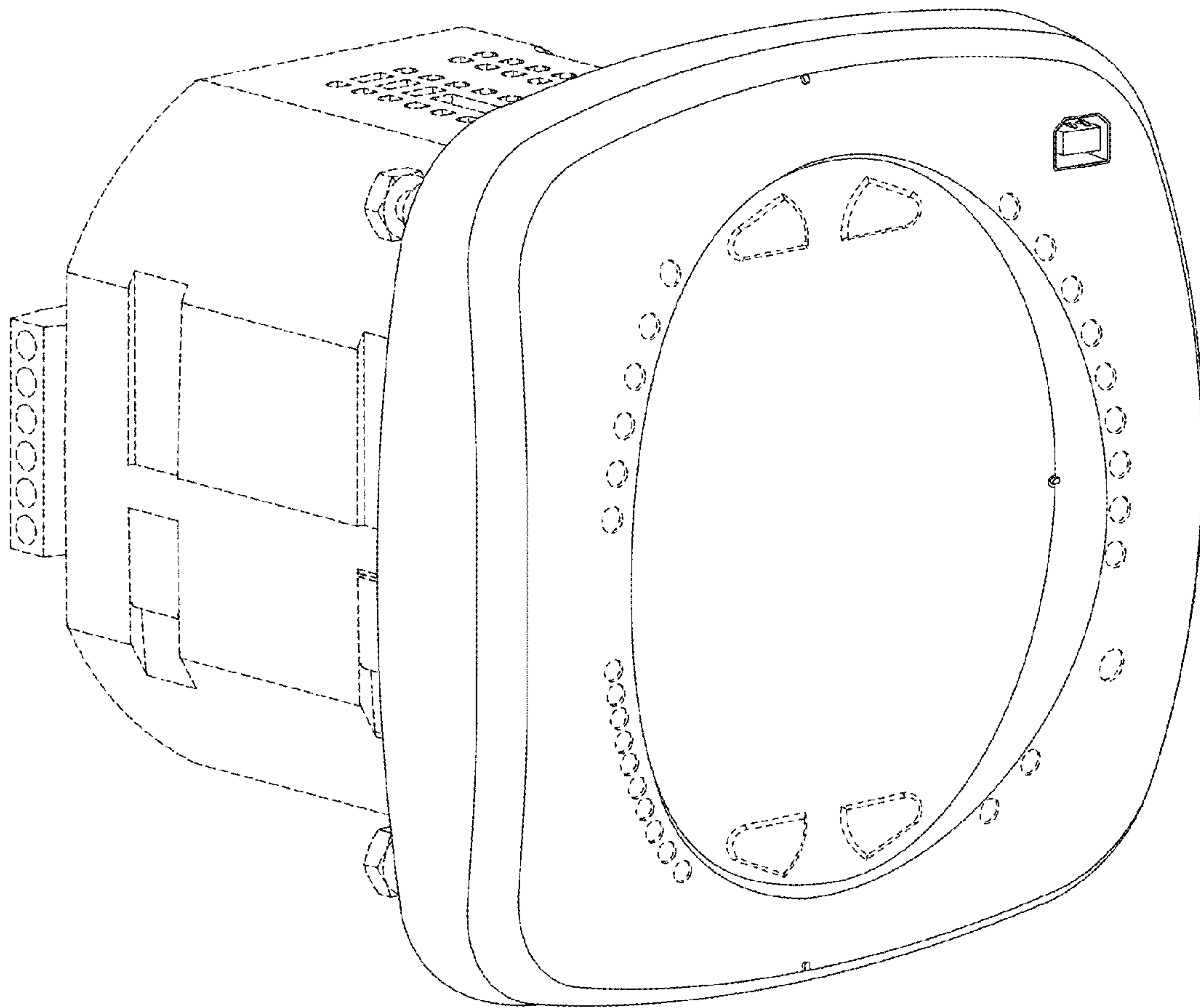

FIG. 29

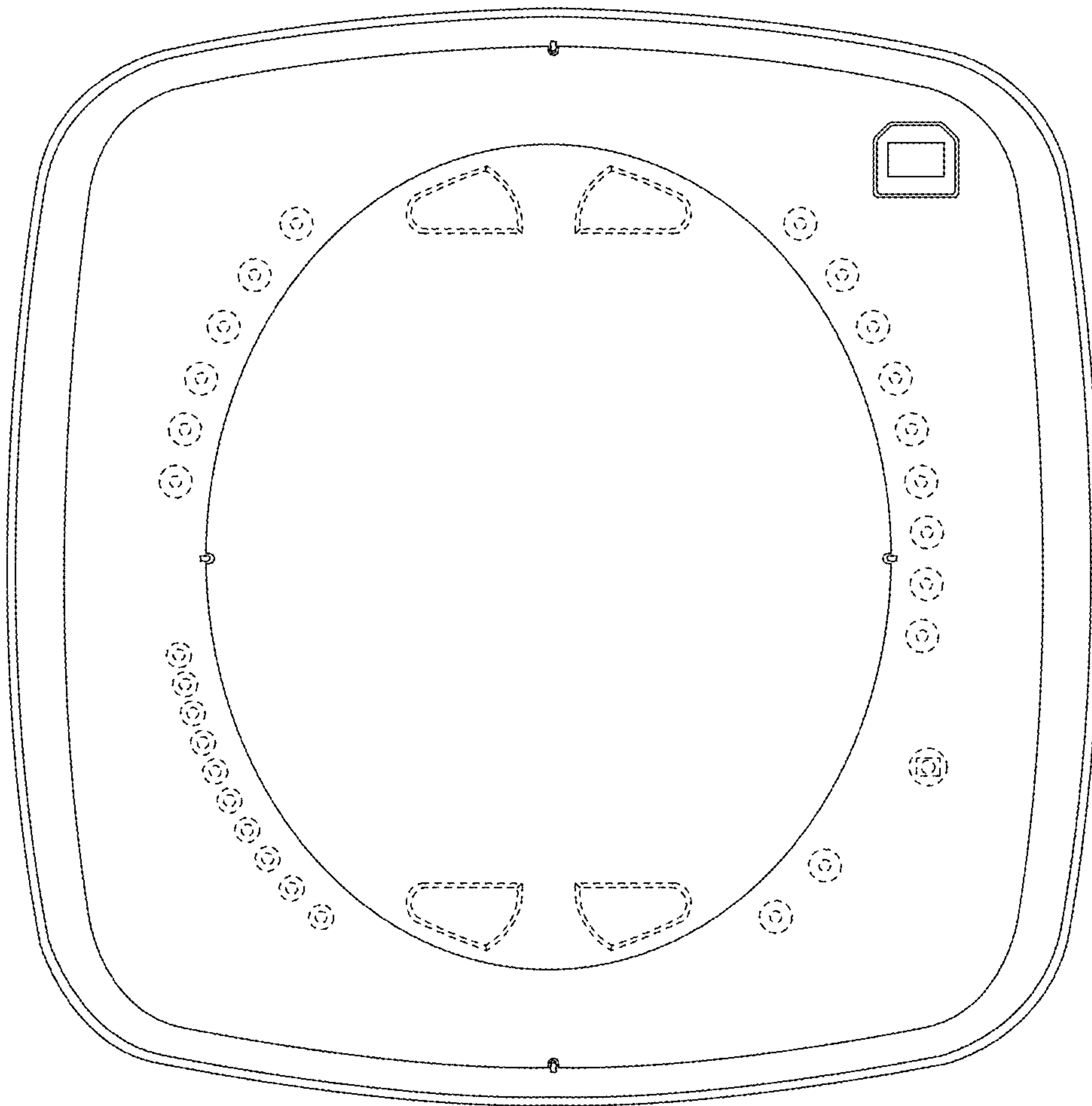

FIG. 30

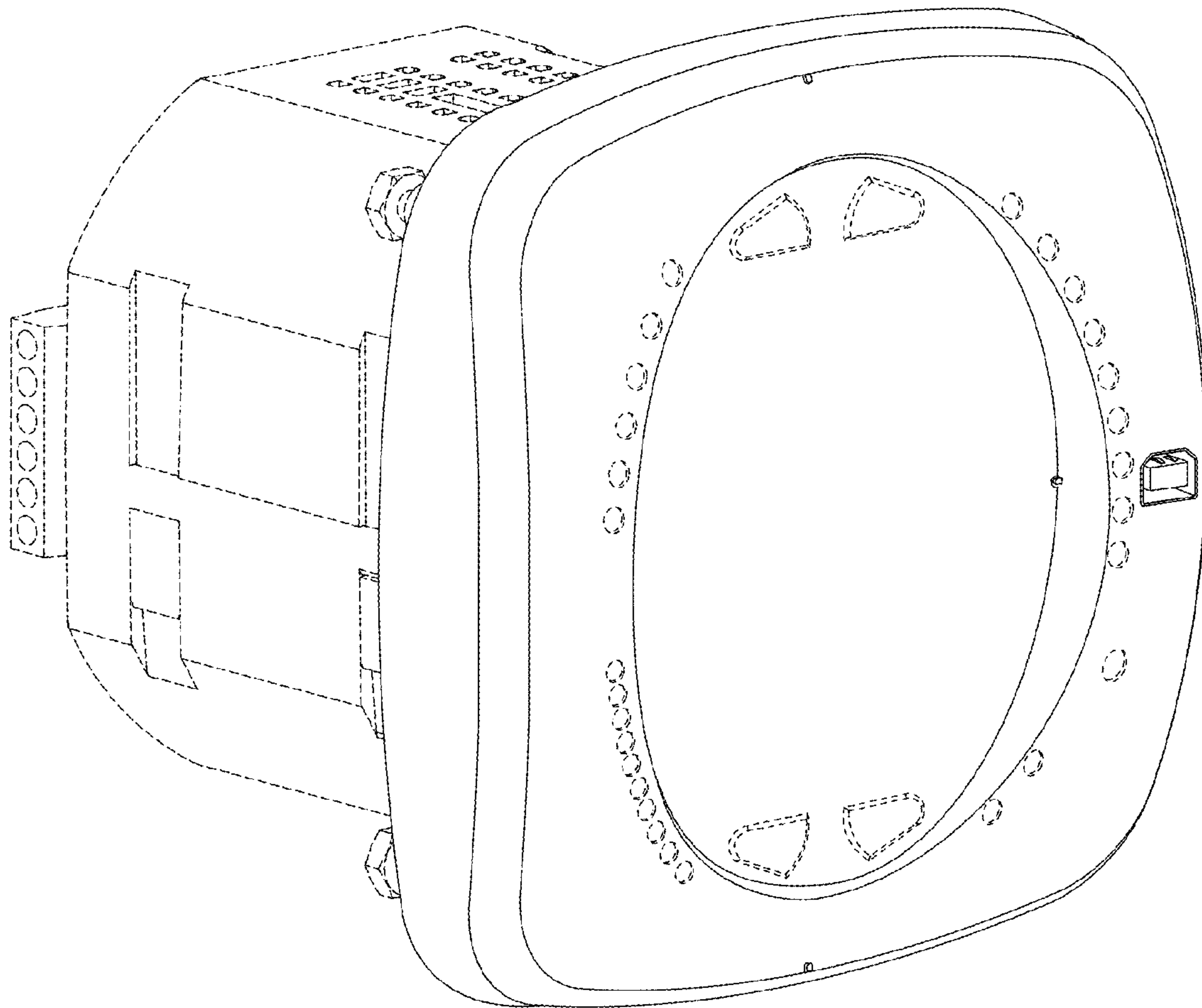

FIG. 31

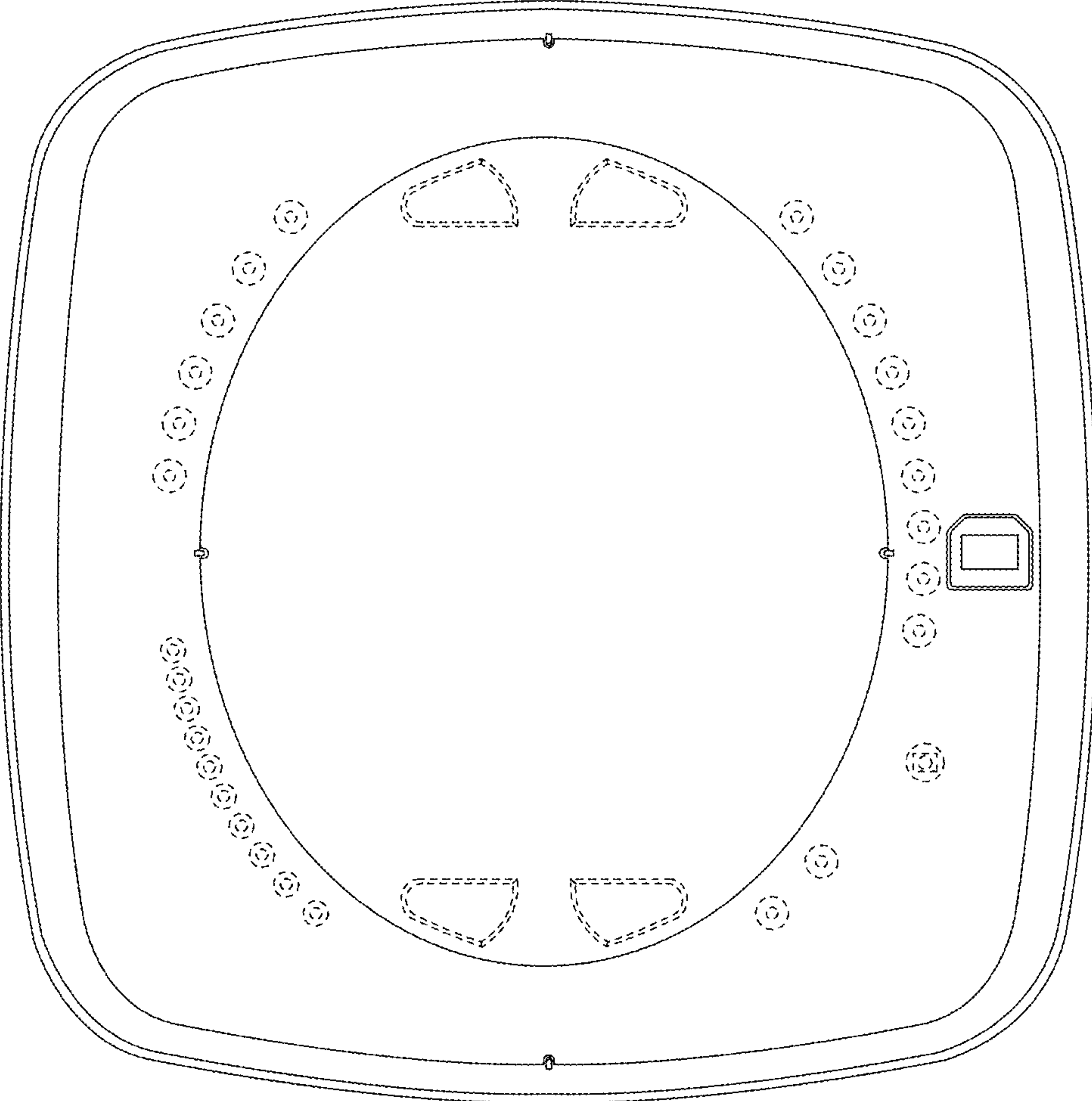

FIG. 32

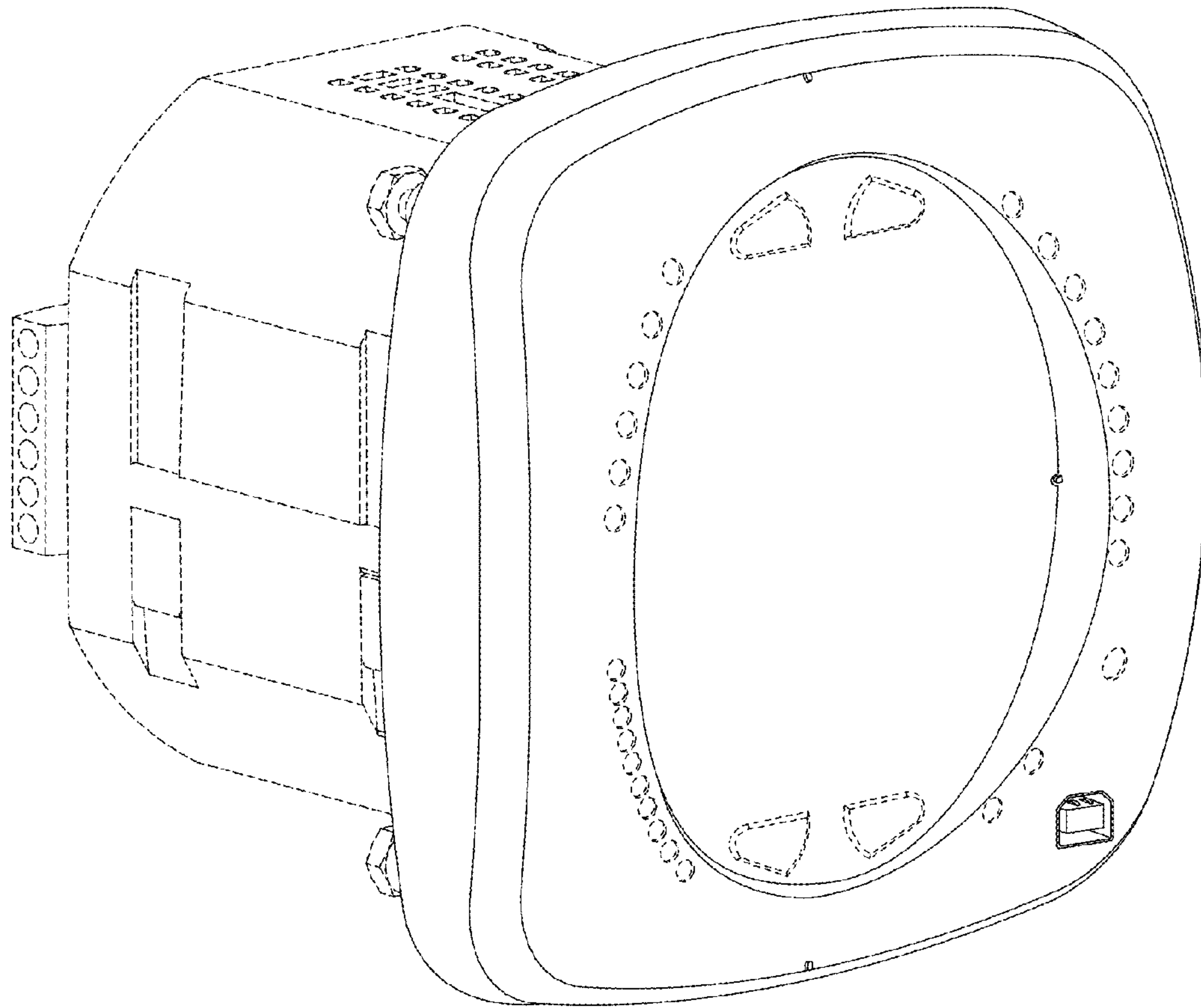

FIG. 33

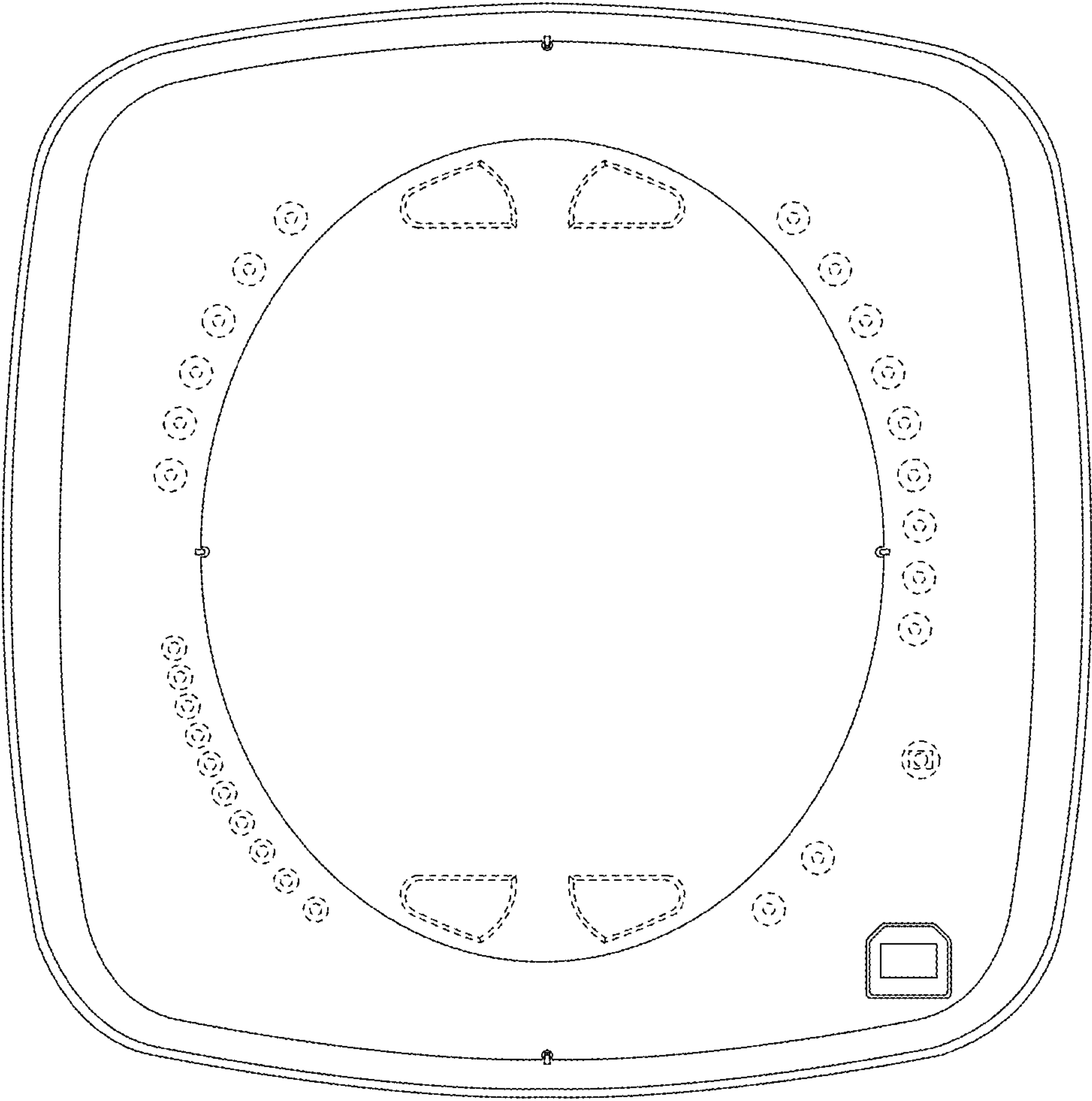

FIG. 34

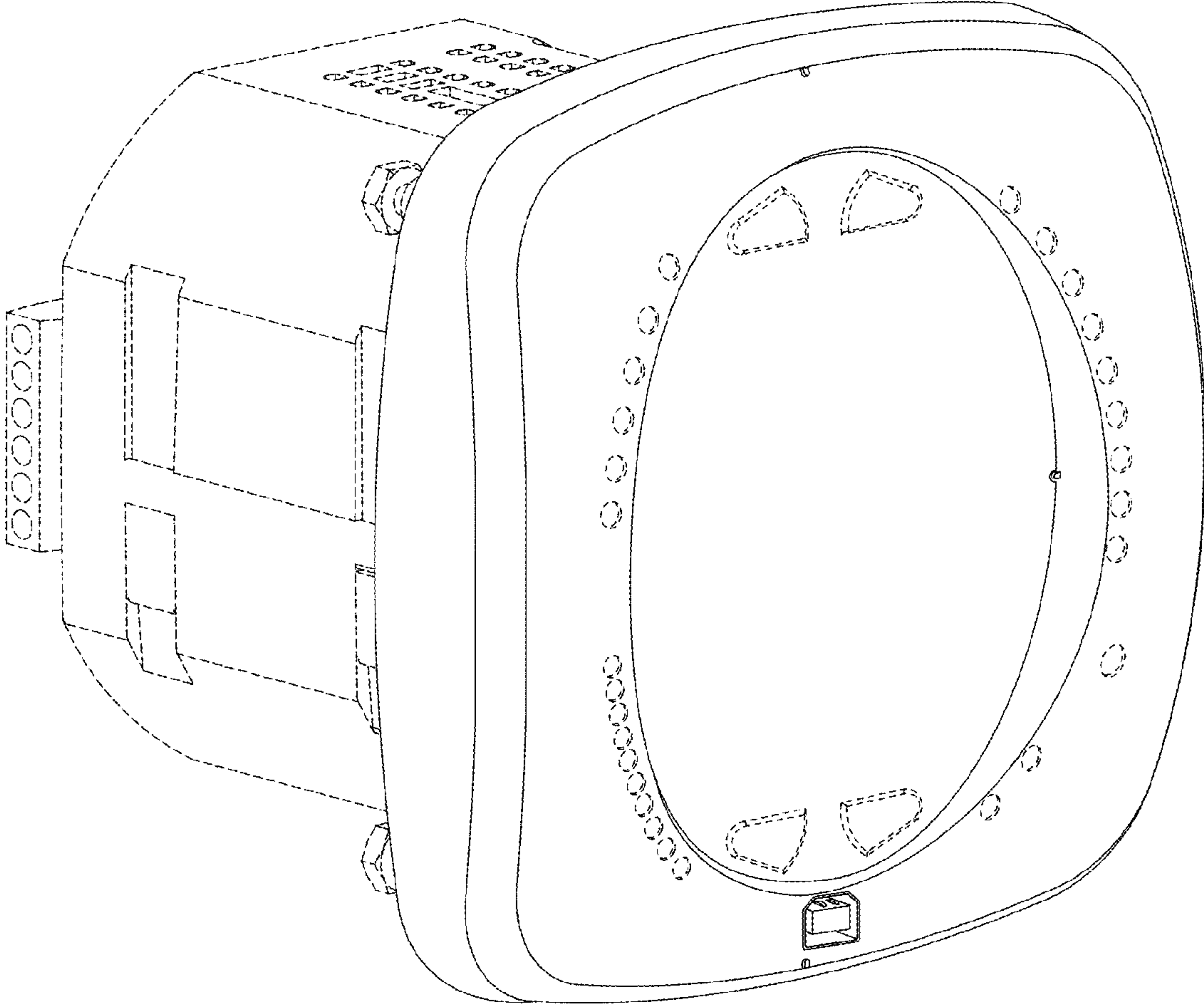

FIG. 35

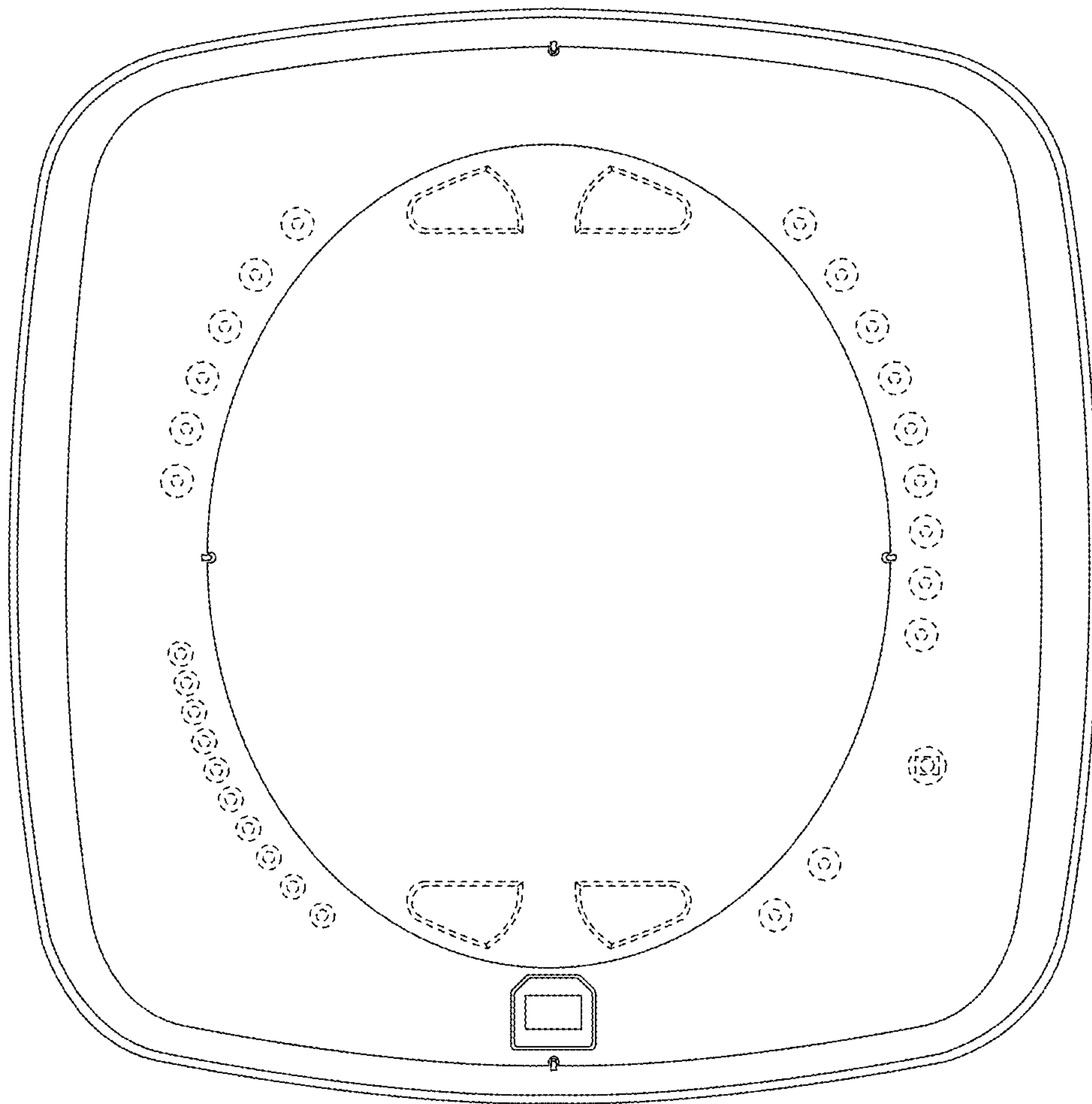

FIG. 36

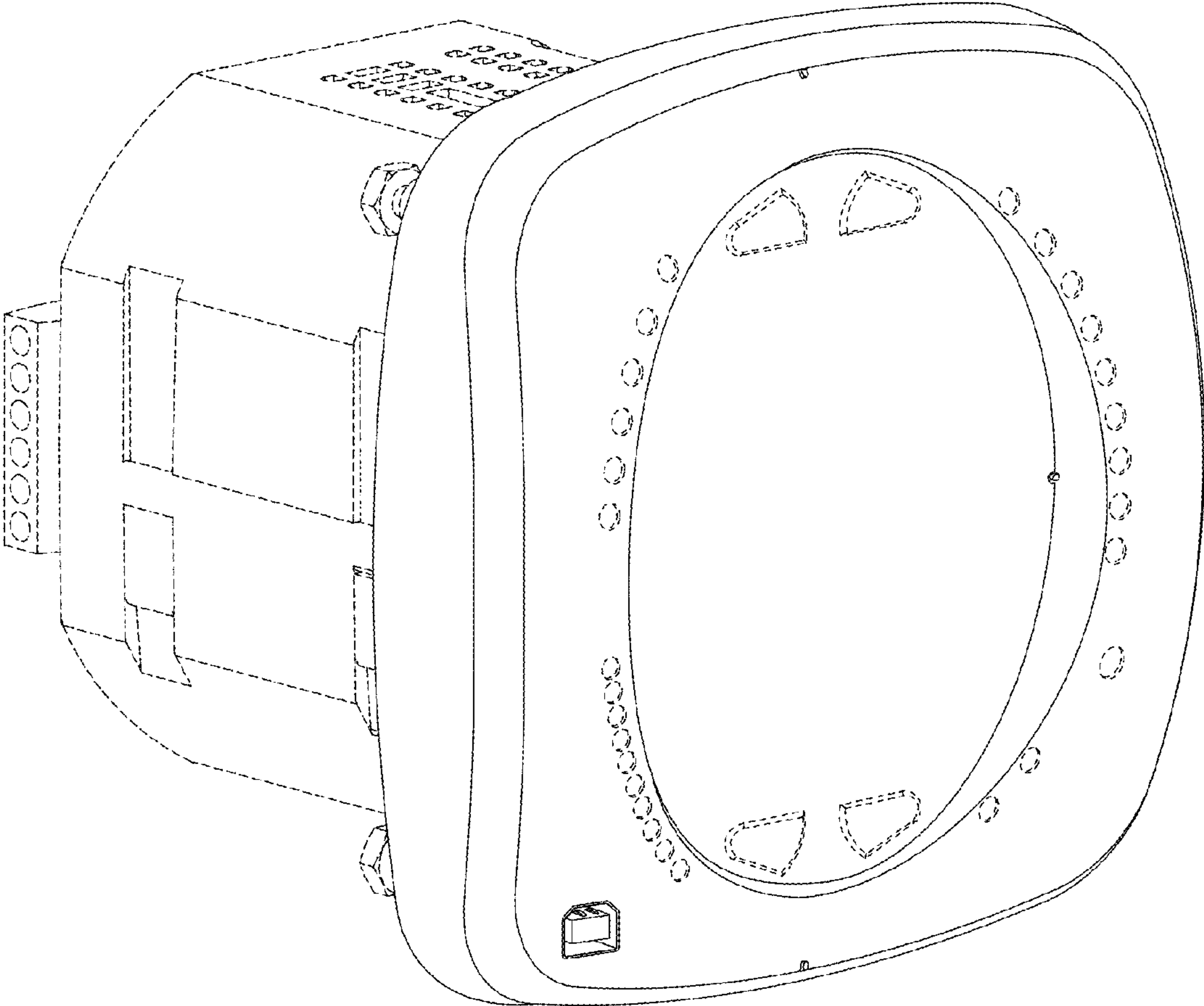

FIG. 37

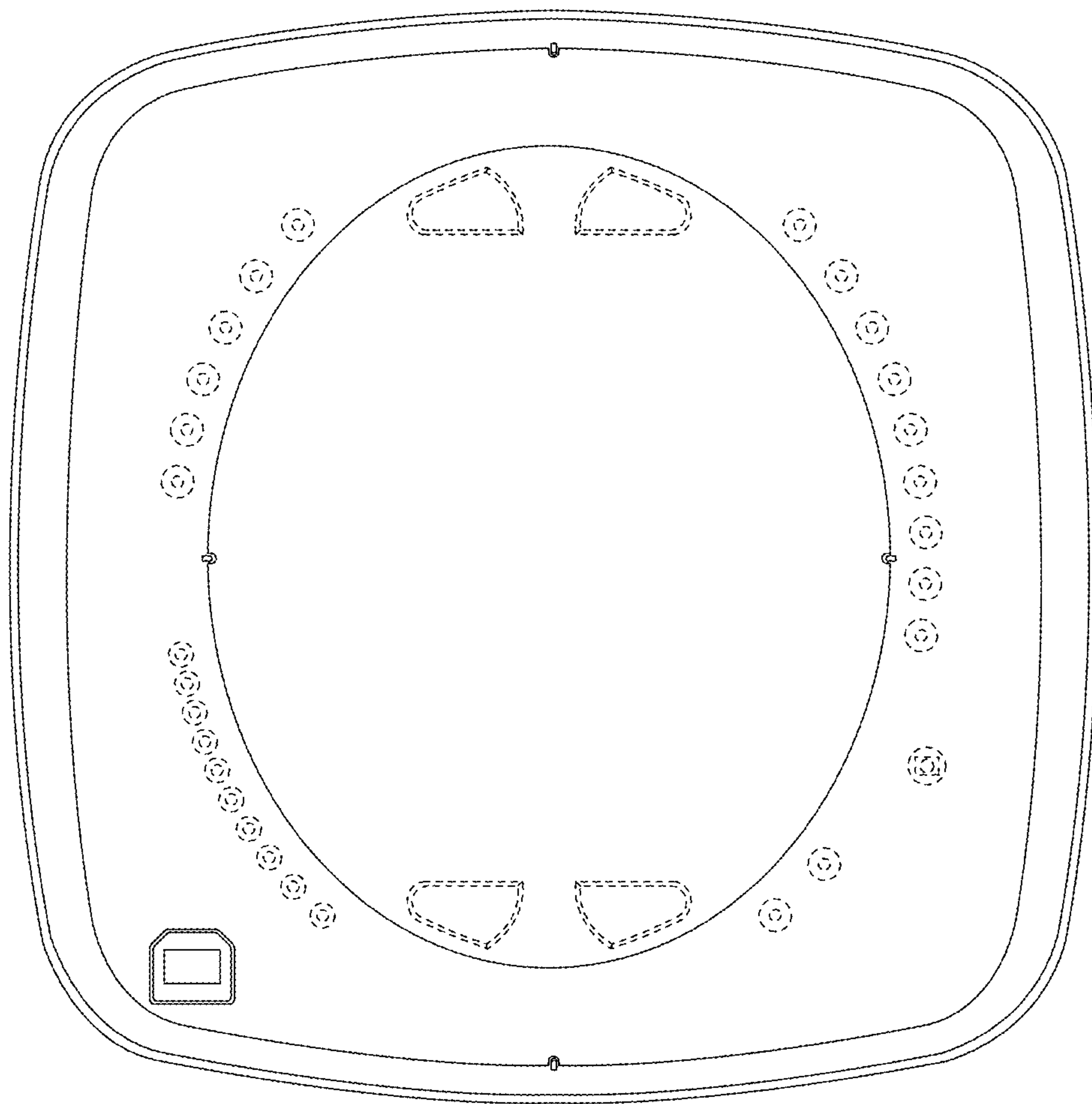

FIG. 38

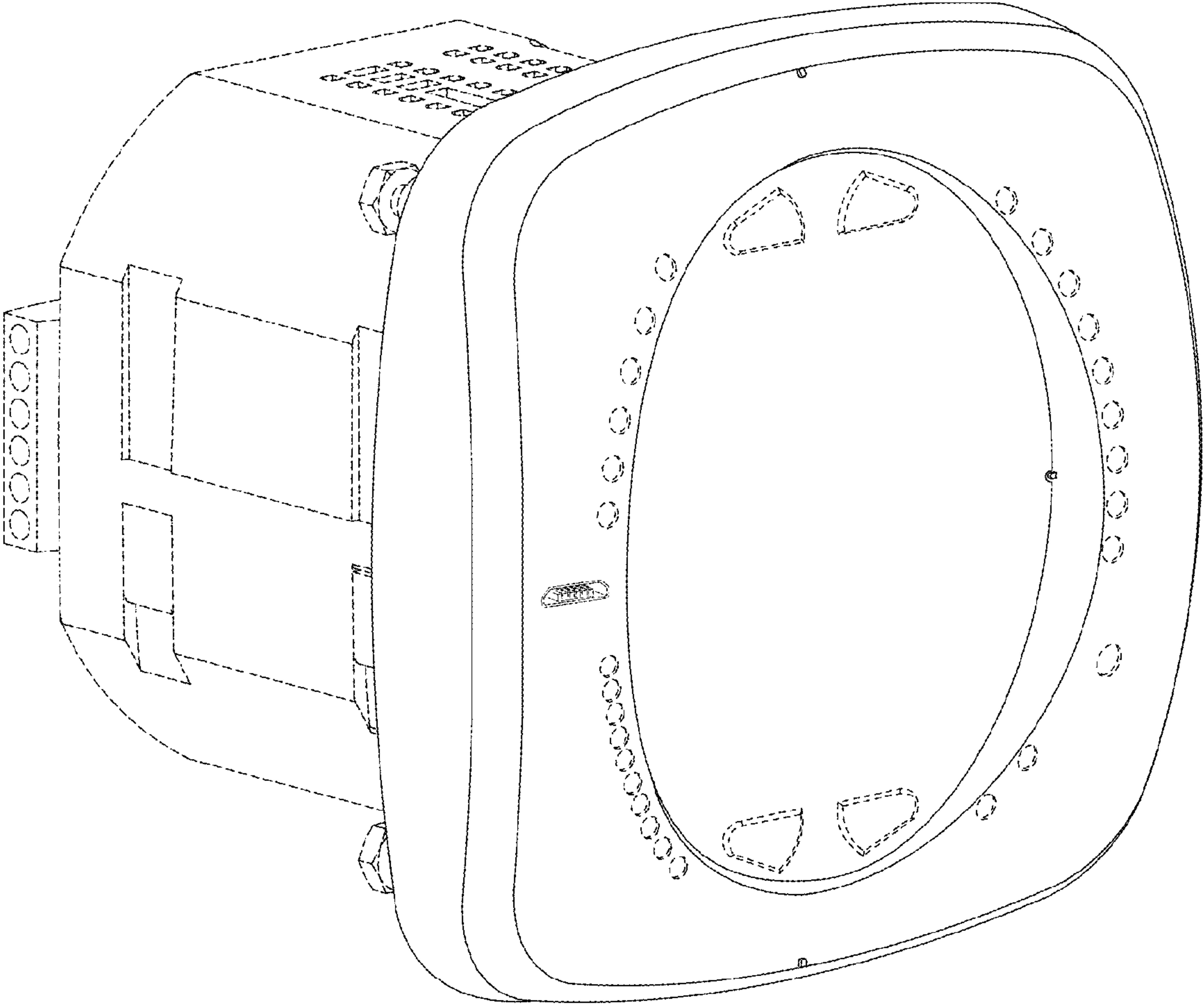

FIG. 39

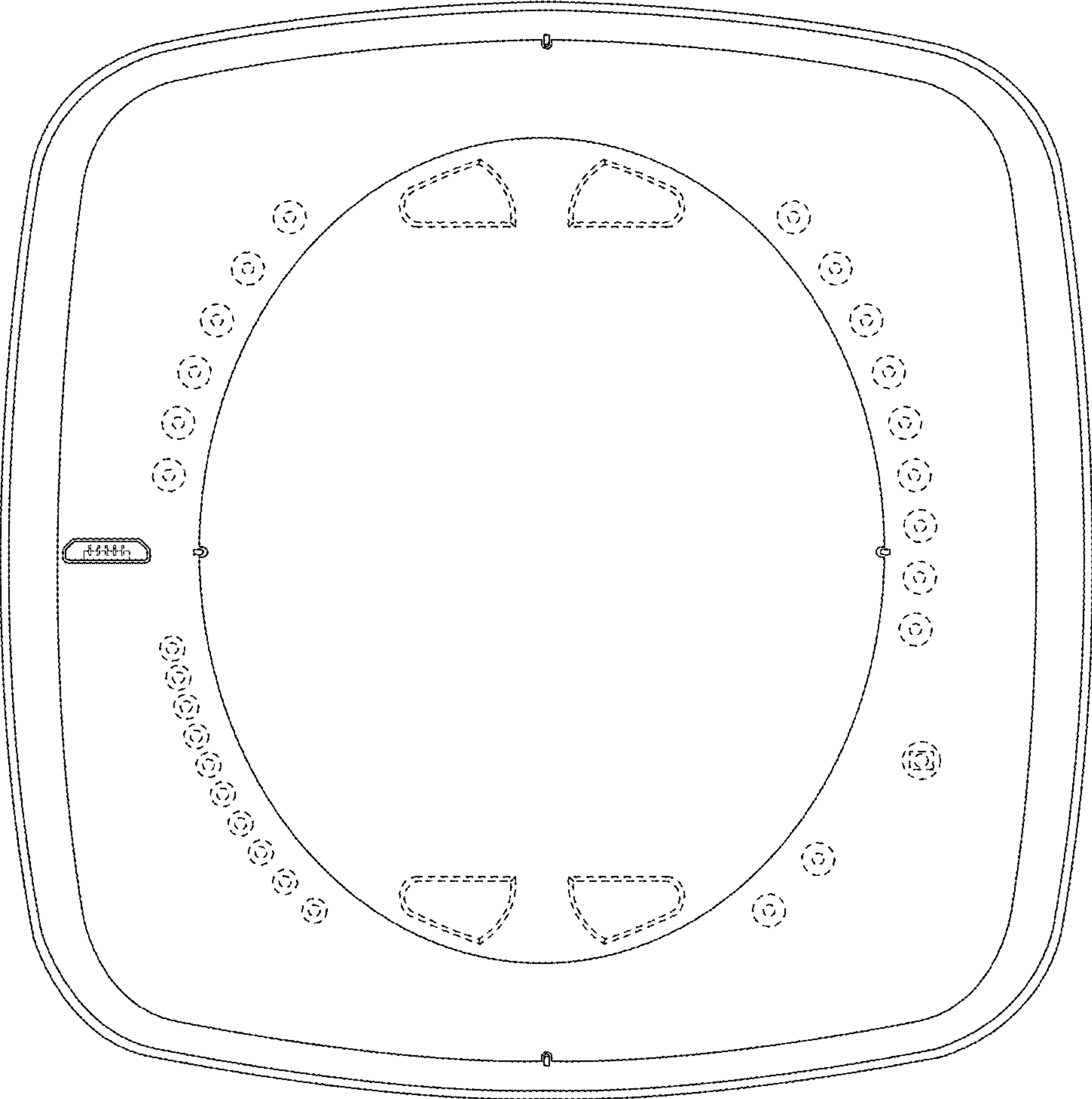

FIG. 40

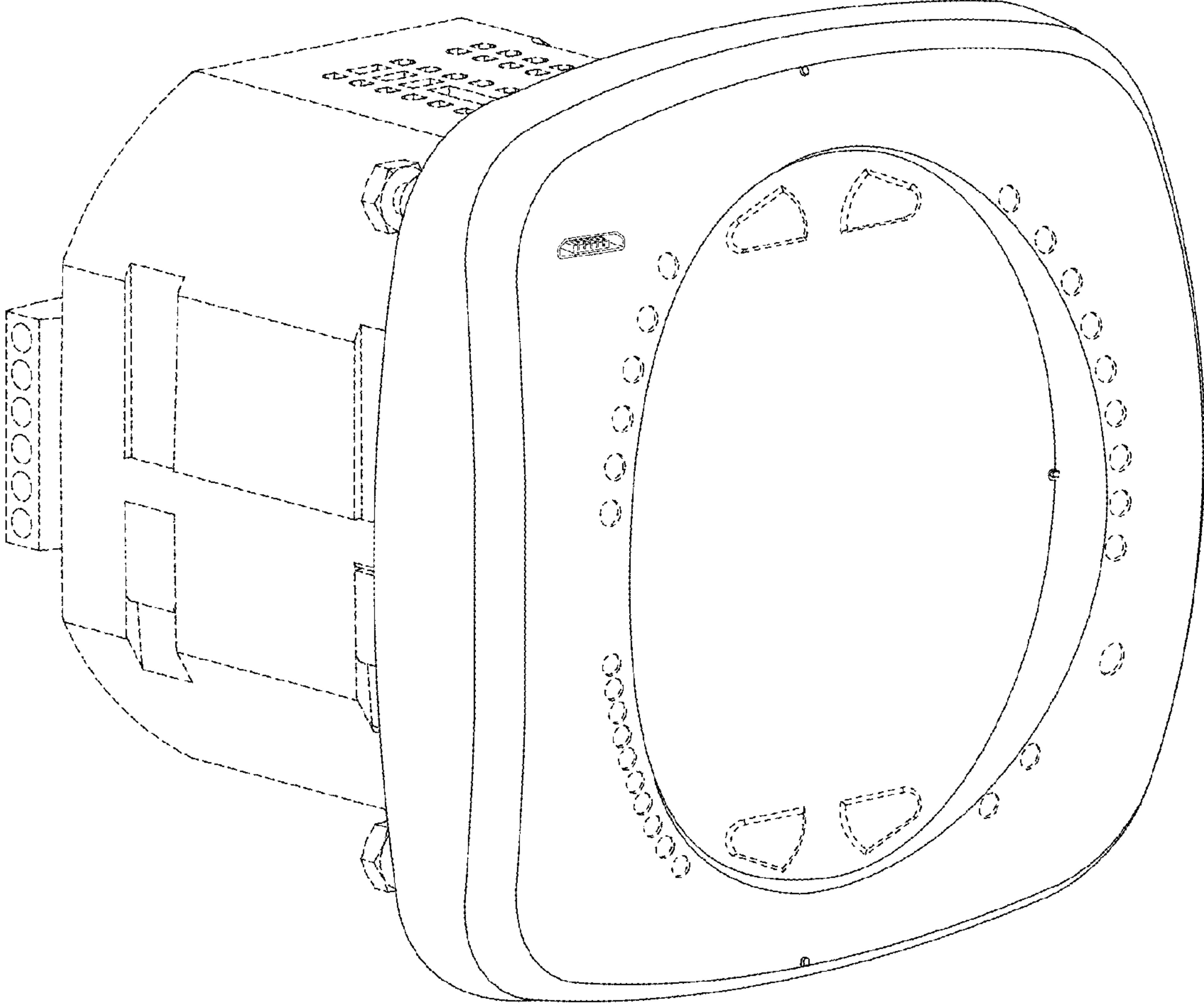

FIG. 41

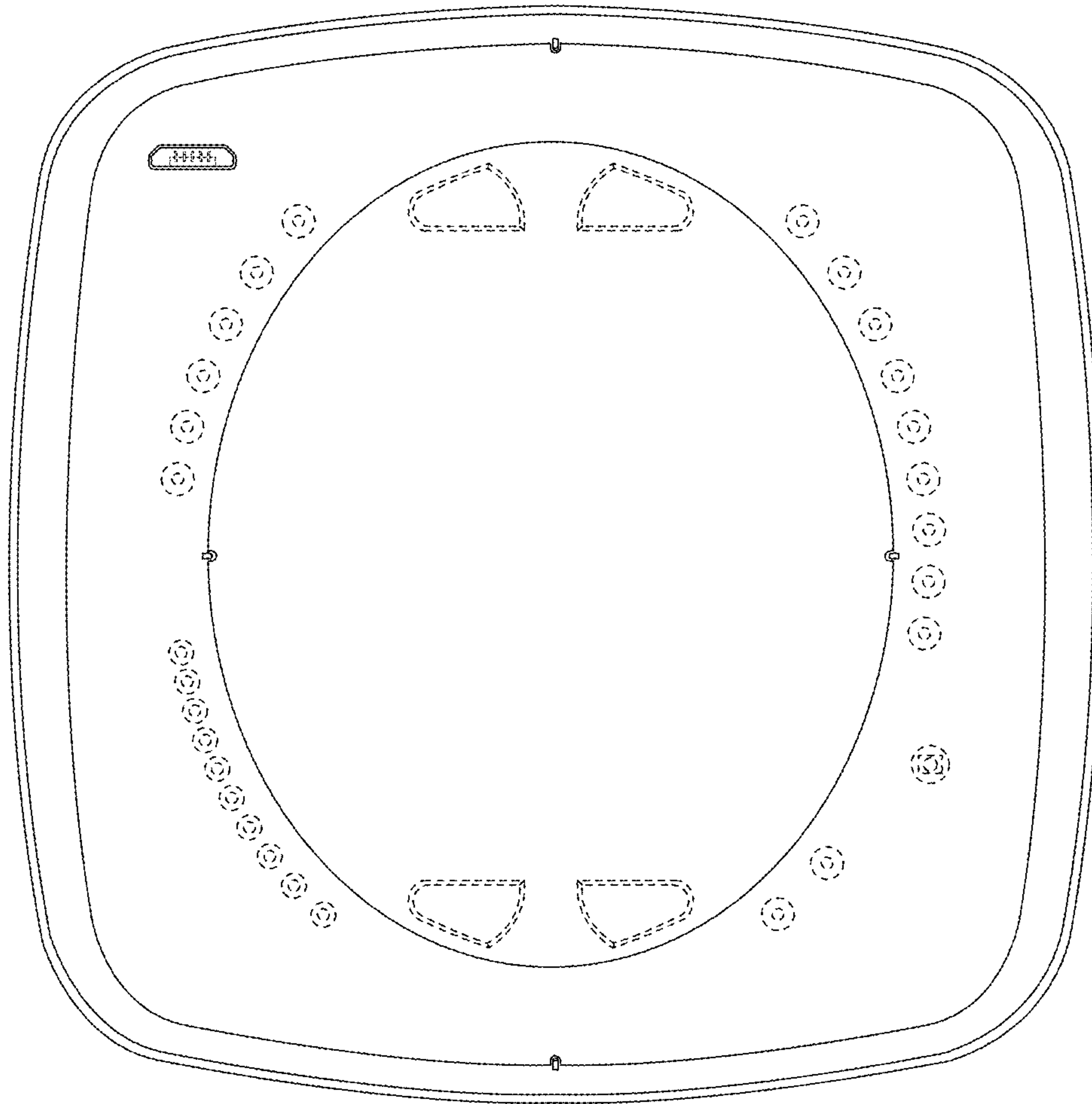

FIG. 42

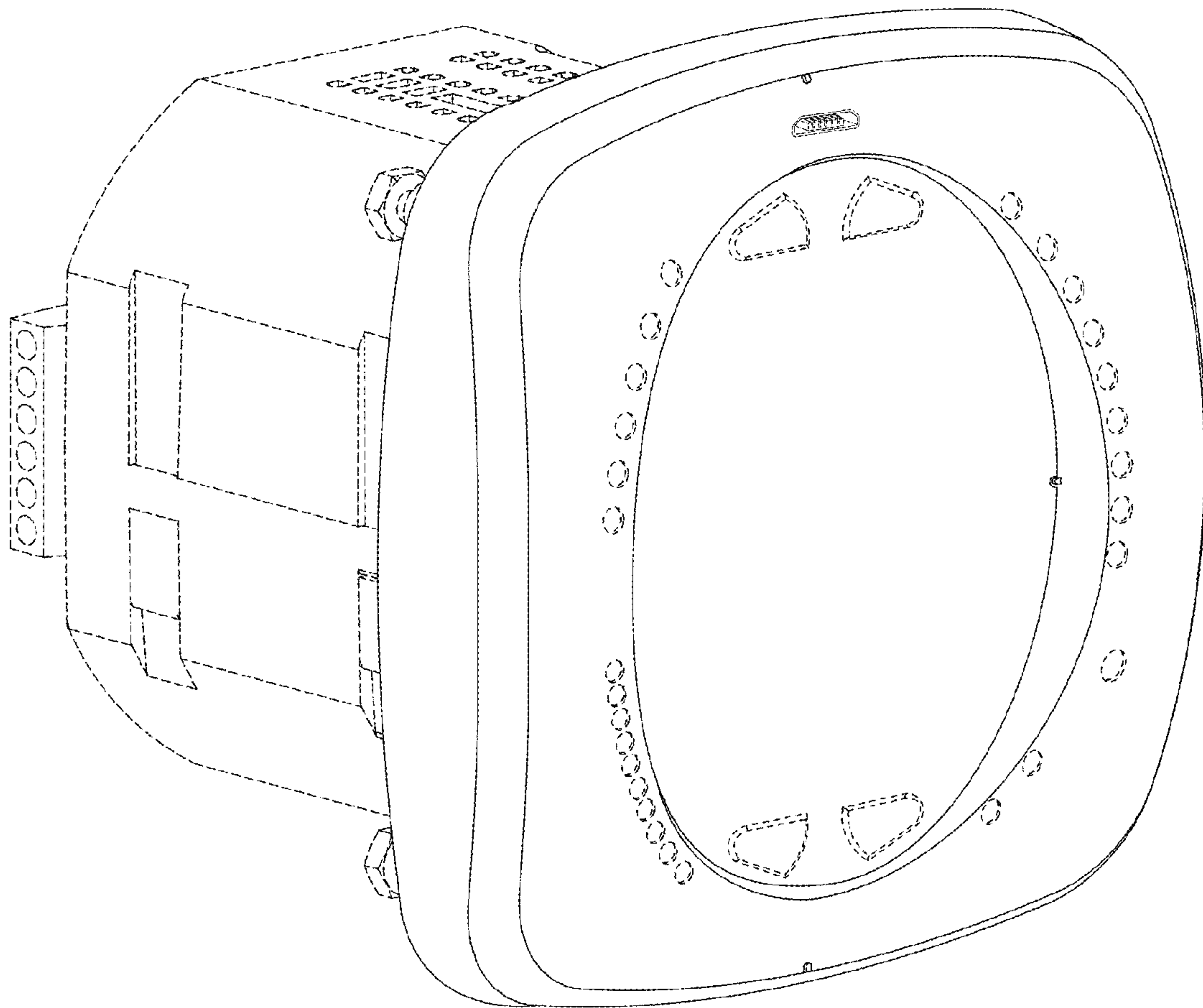

FIG. 43

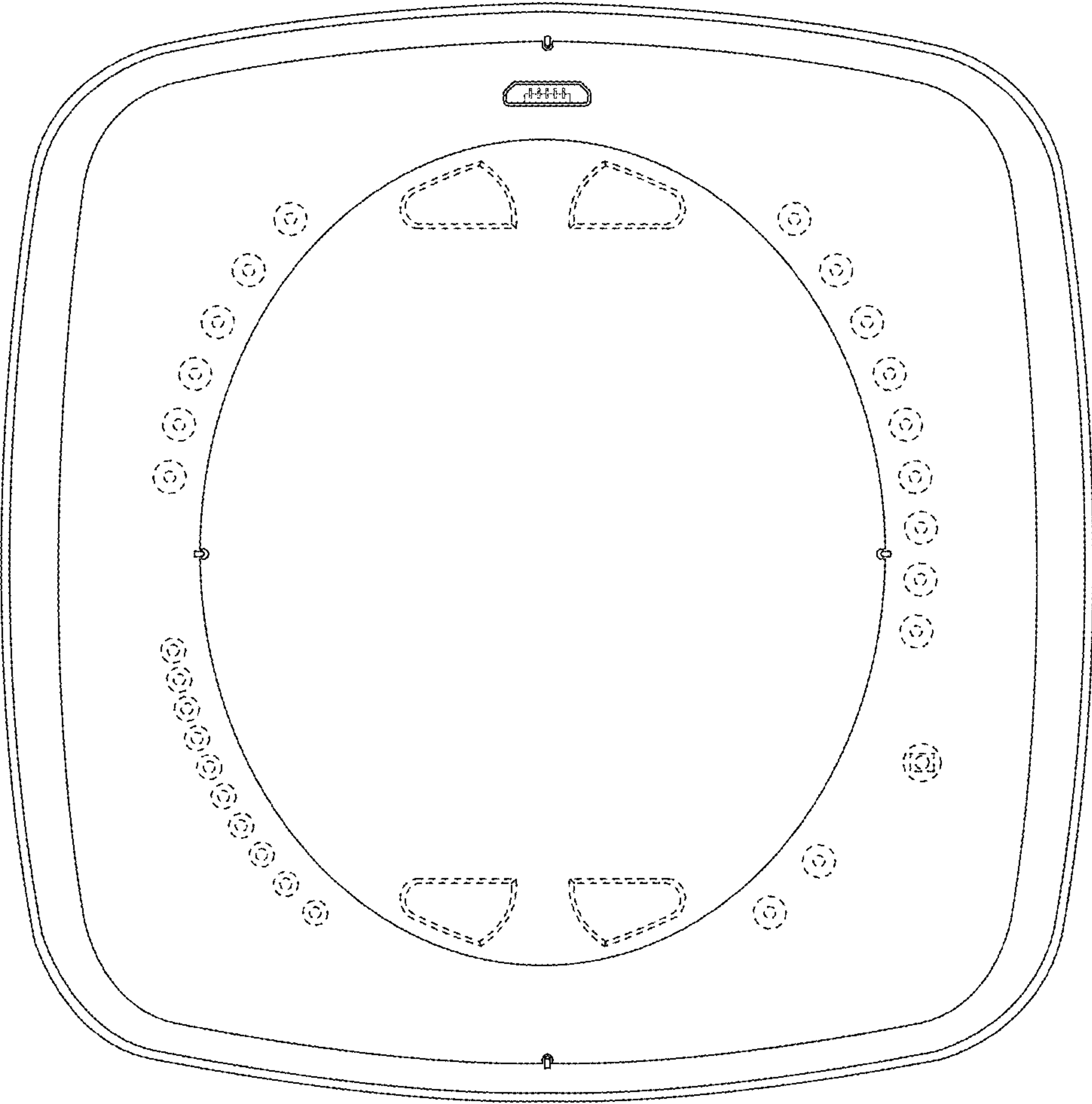

FIG. 44

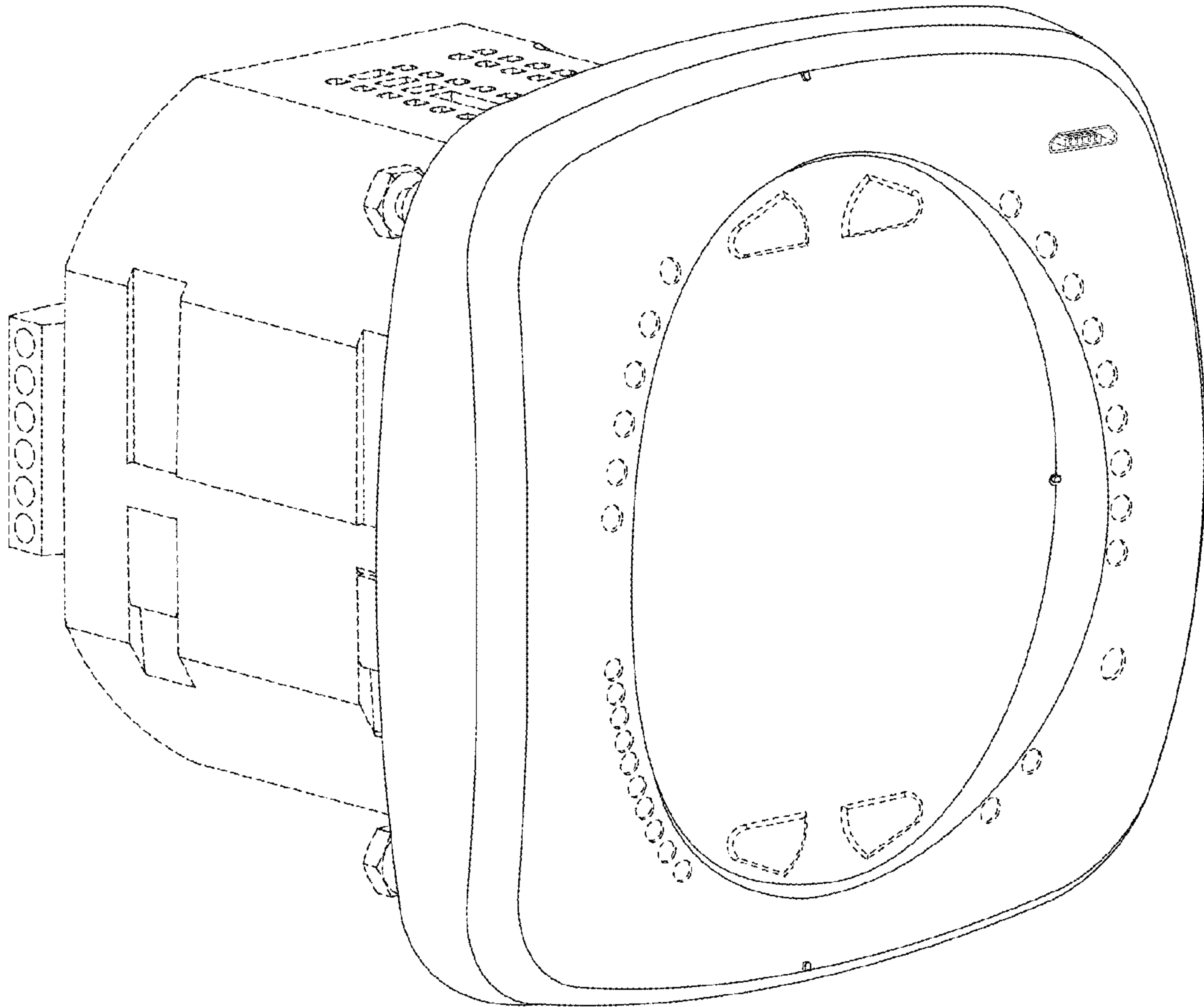

FIG. 45

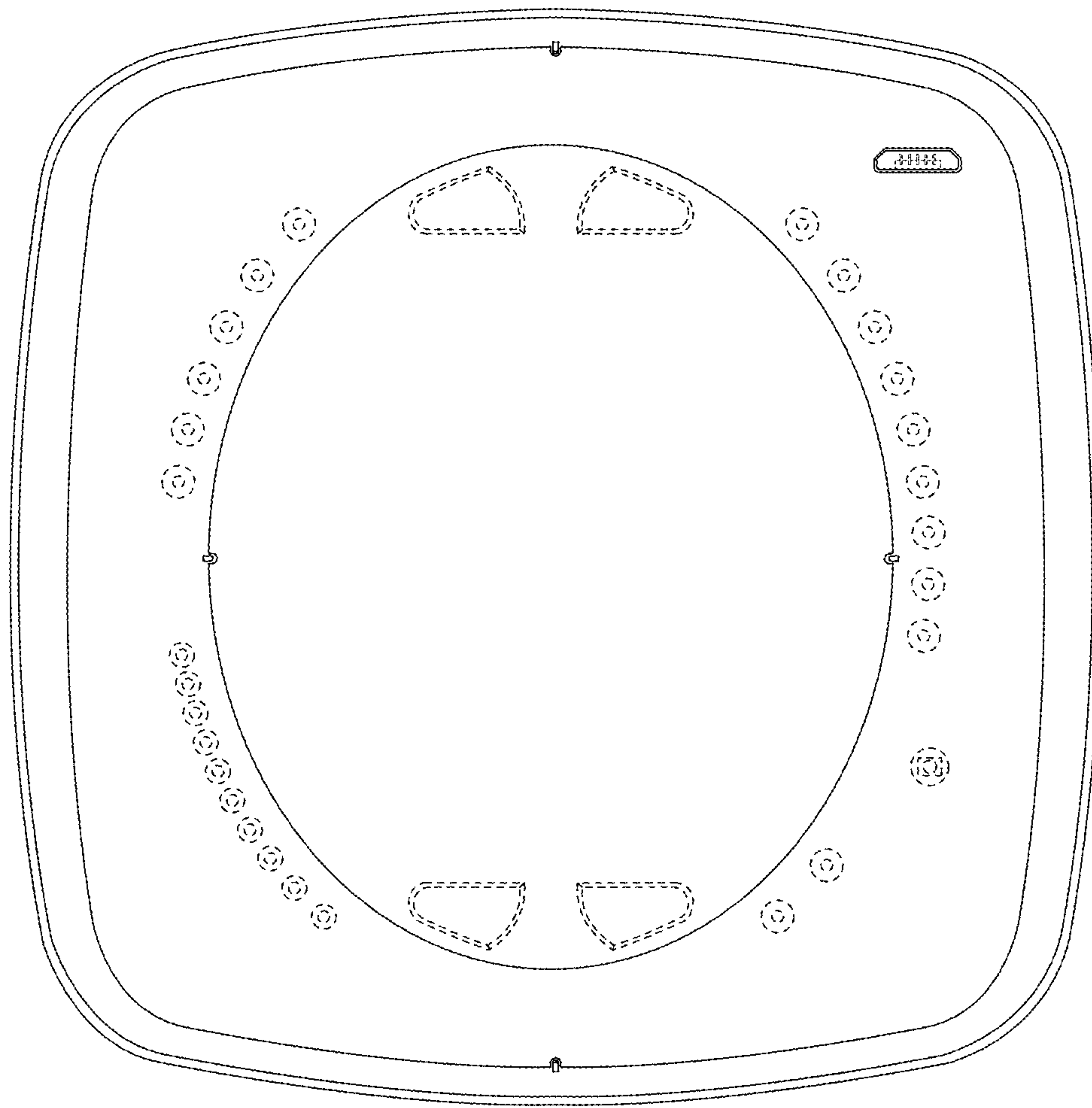

FIG. 46

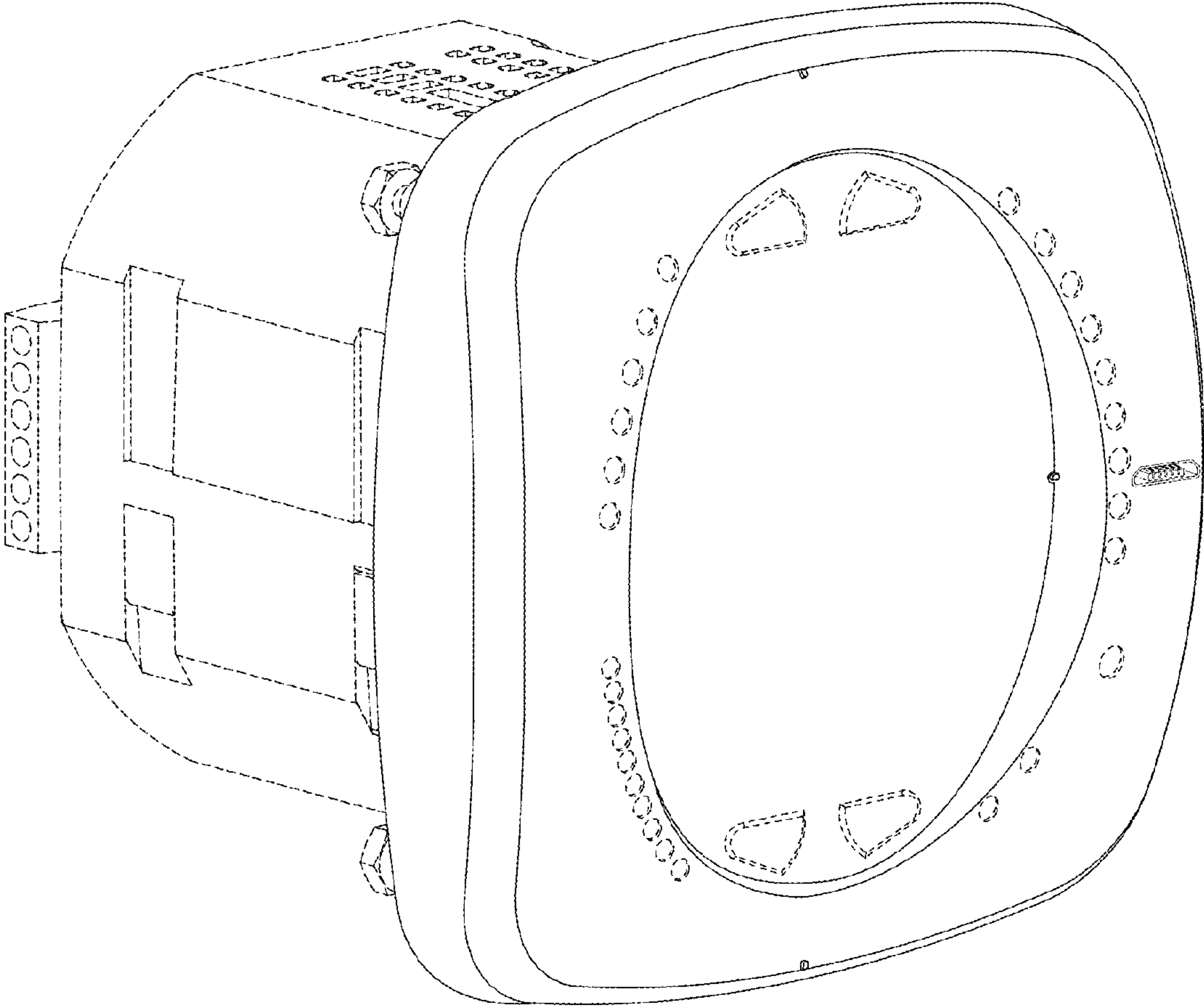

FIG. 47

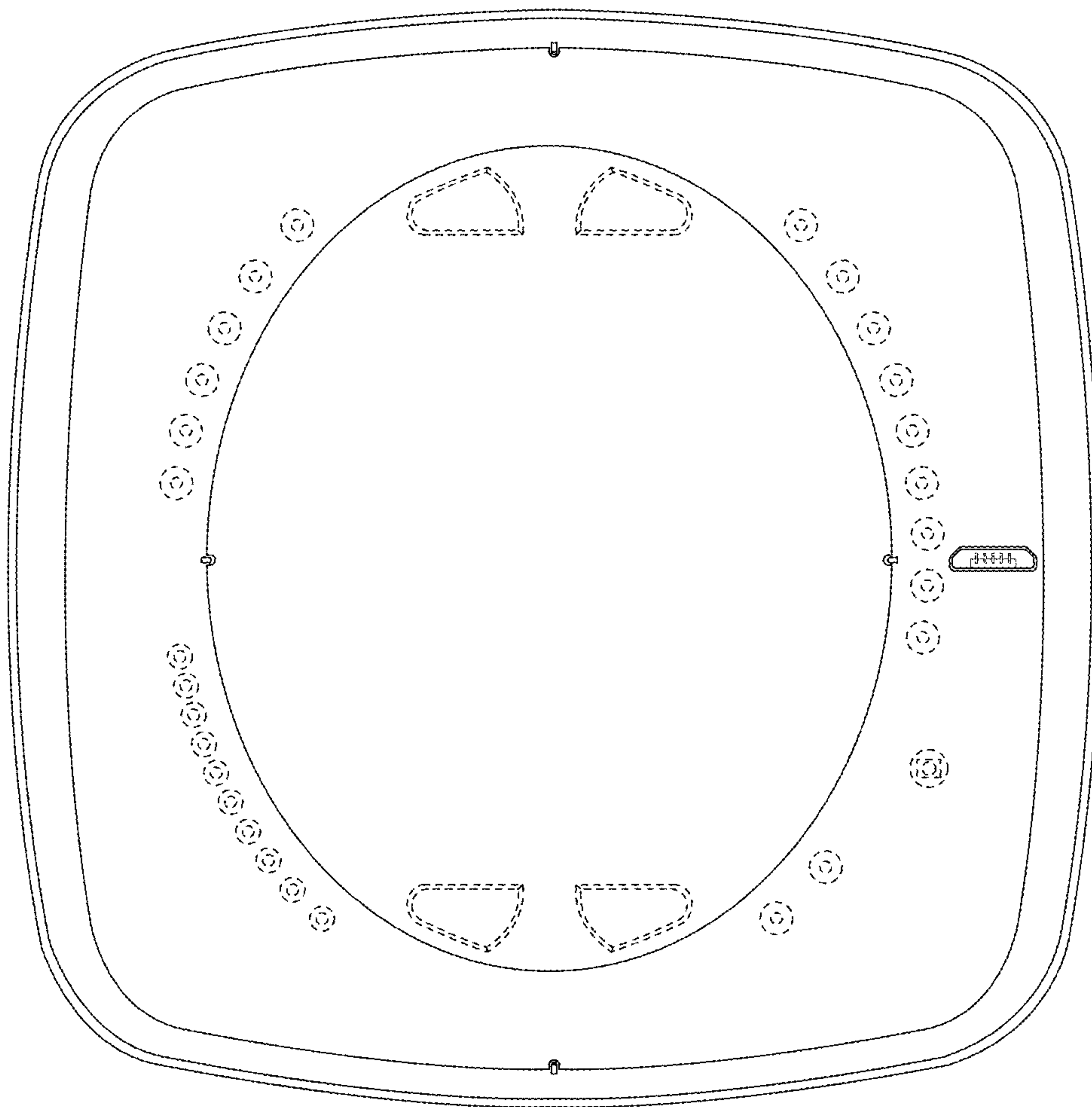

FIG. 48

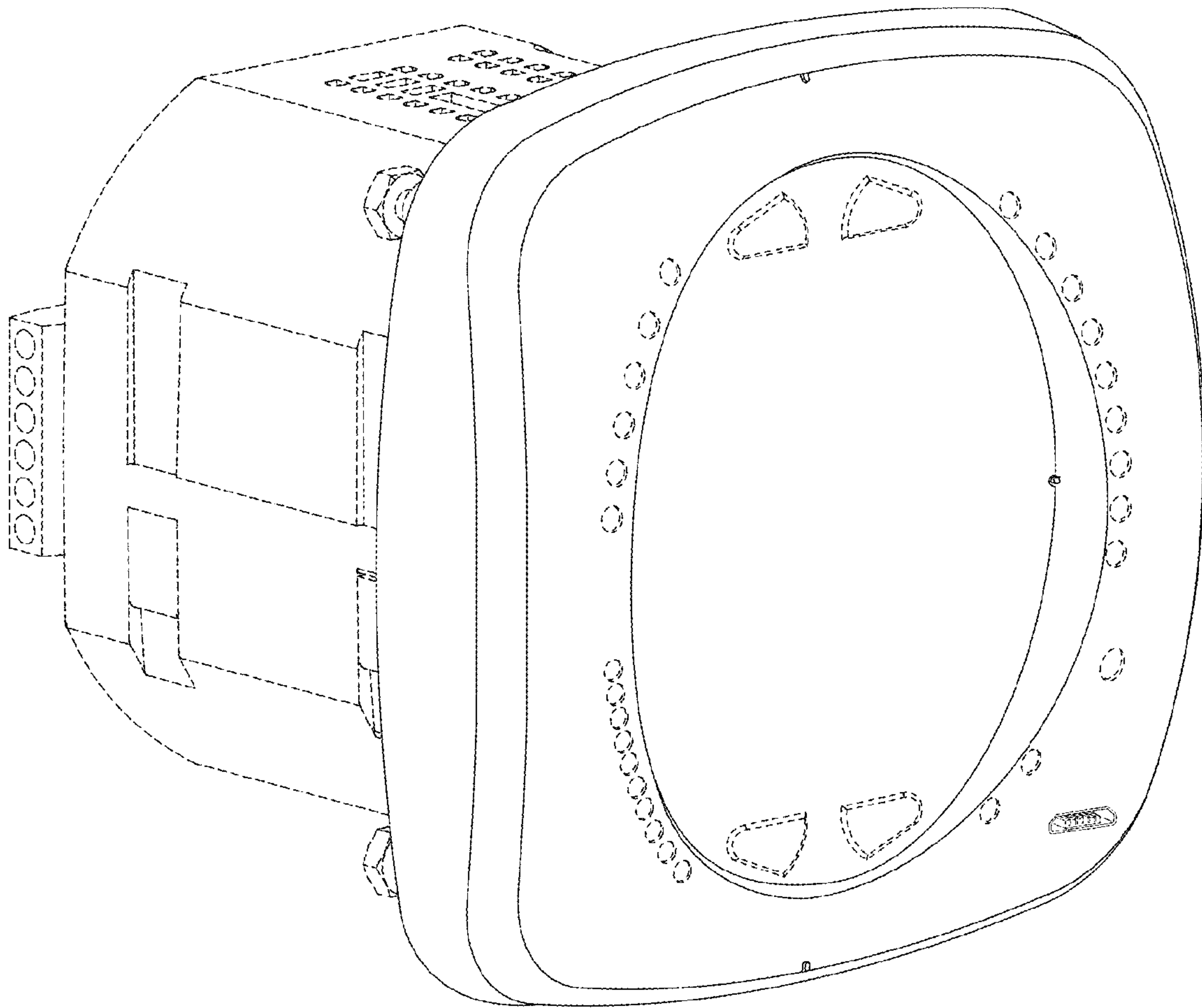

FIG. 49

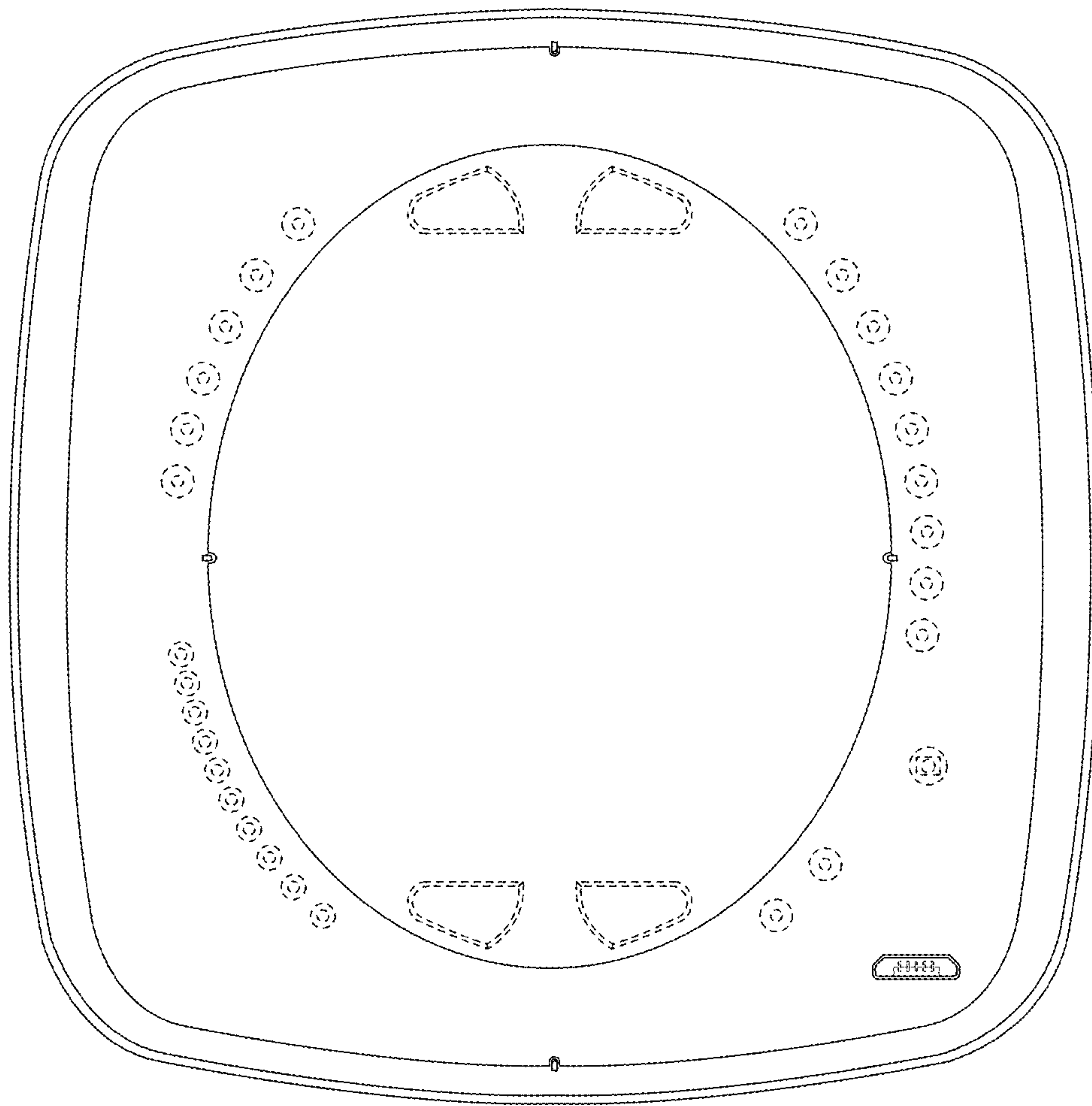

FIG. 50

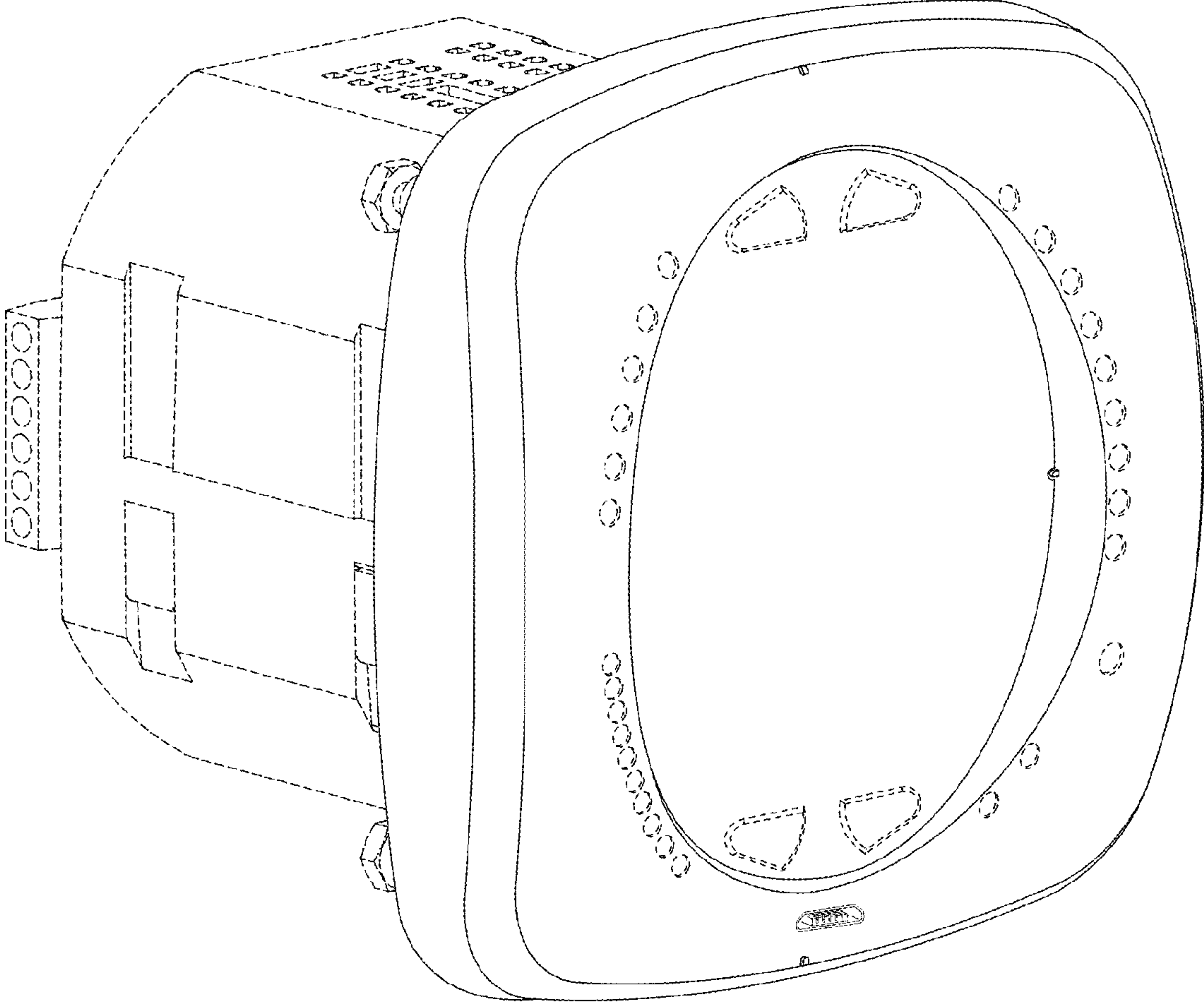

FIG. 51

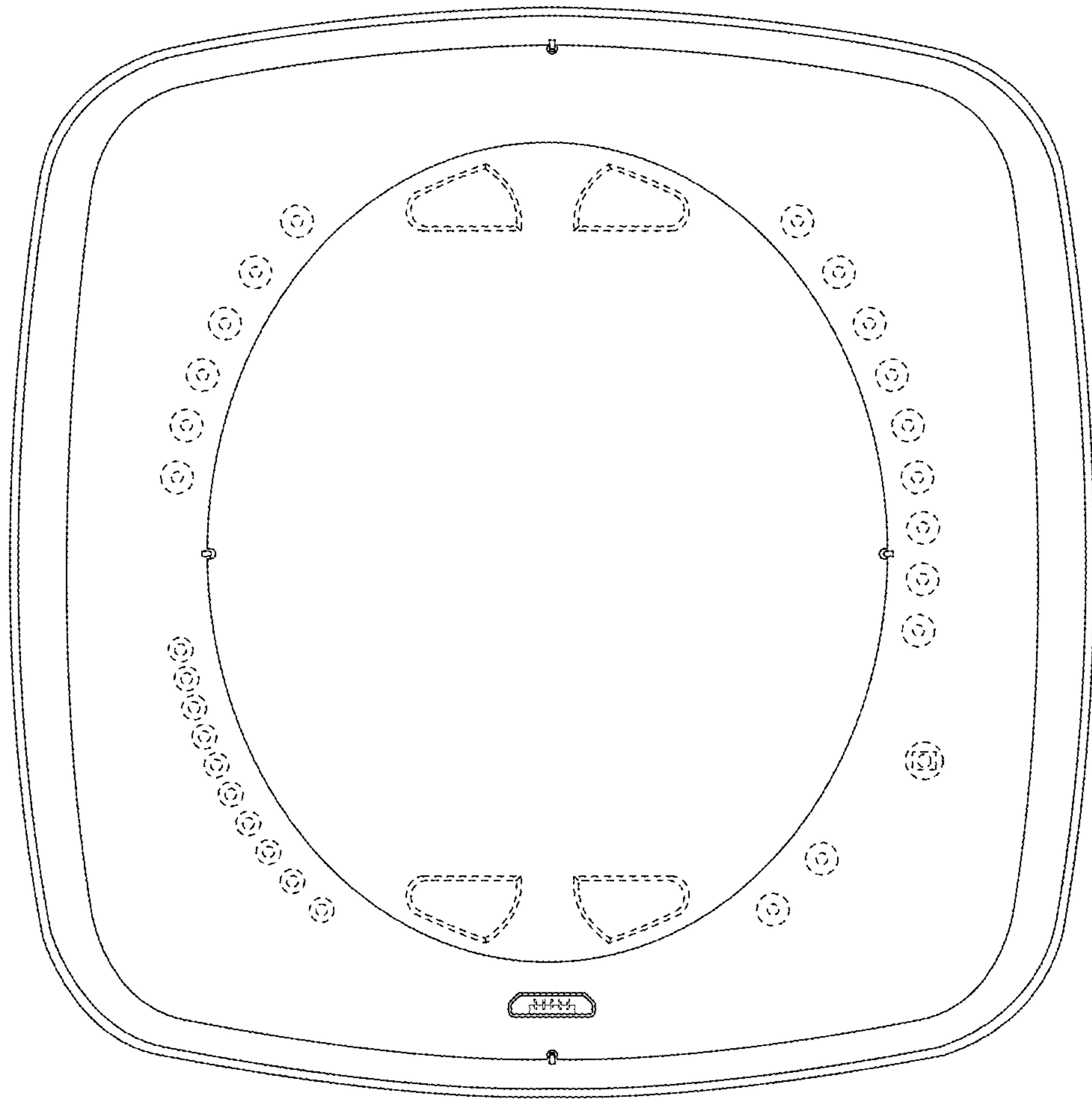

FIG. 52

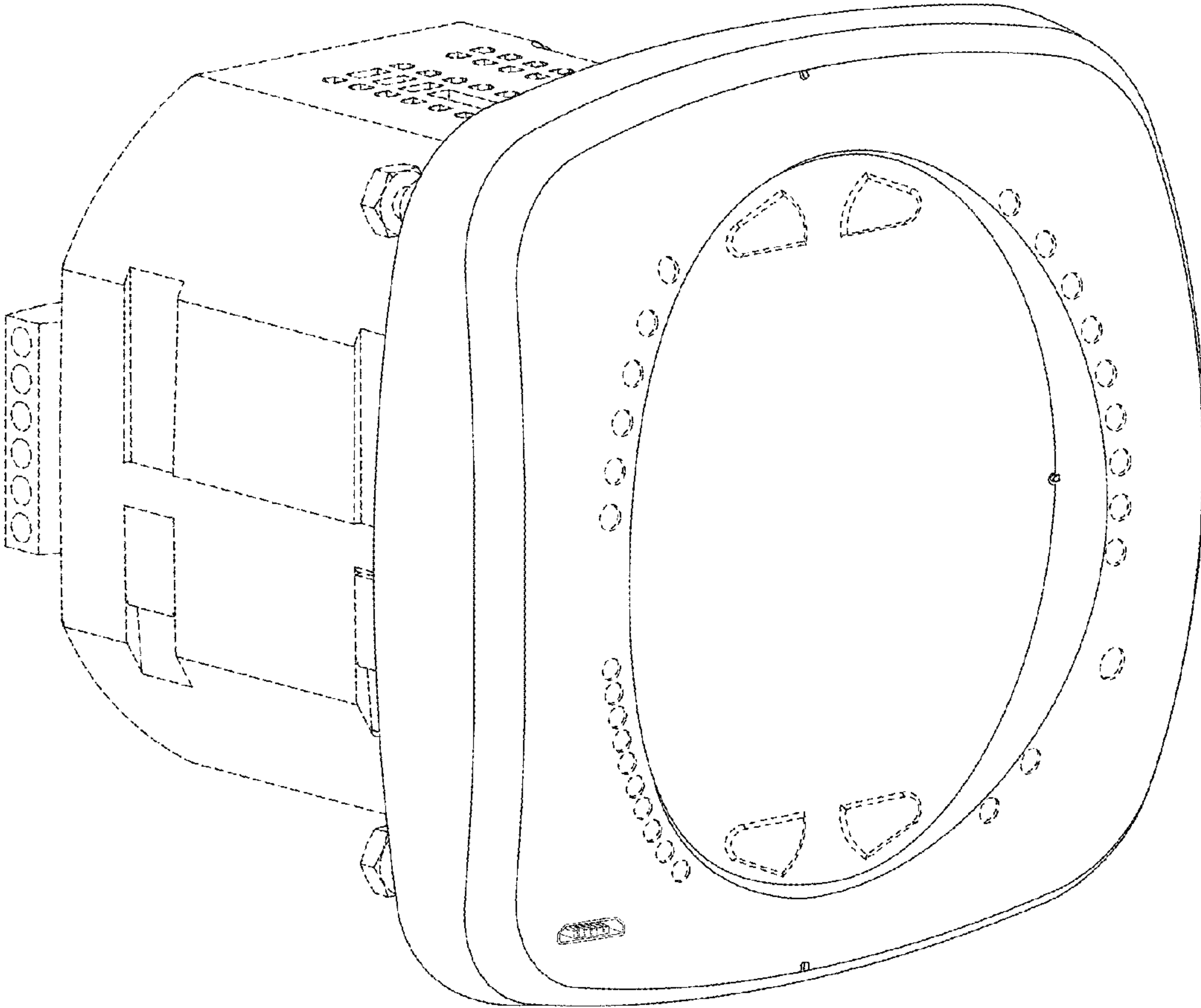

FIG. 53

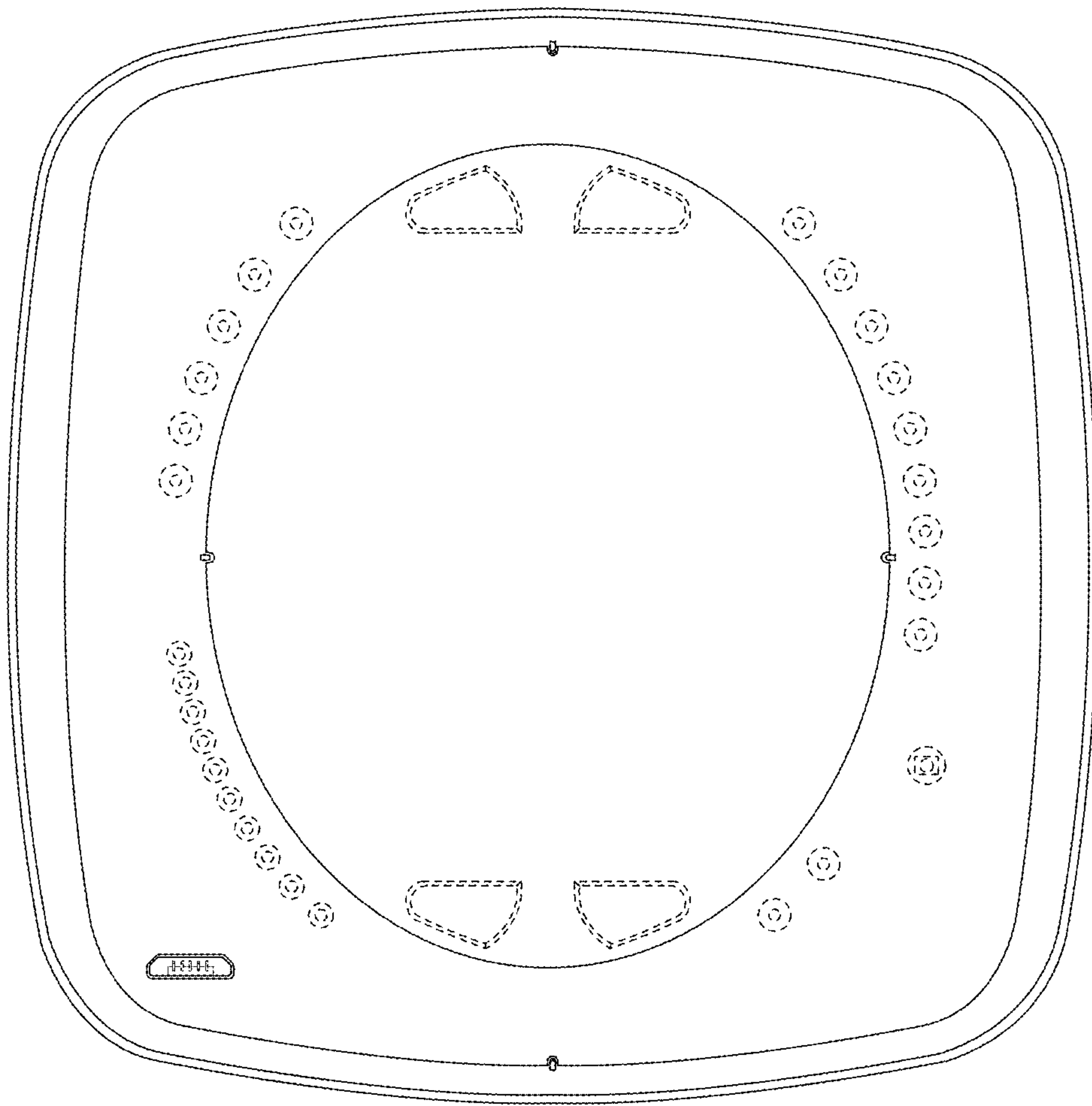

FIG. 54