



US00D738464S

(12) **United States Design Patent**
Yoshida et al.

(10) **Patent No.:** **US D738,464 S**

(45) **Date of Patent:** **** Sep. 8, 2015**

(54) **ELECTROMAGNETIC VALVE**

(71) Applicants: **Masami Yoshida**, Tsukubamirai (JP);
Tomoaki Yamada, Tsukubamirai (JP);
Hikaru Tsuyuki, Tsukubamirai (JP)

(72) Inventors: **Masami Yoshida**, Tsukubamirai (JP);
Tomoaki Yamada, Tsukubamirai (JP);
Hikaru Tsuyuki, Tsukubamirai (JP)

(73) Assignee: **SMC Corporation**, Chiyoda-ku, Tokyo
(JP)

(**) Term: **14 Years**

(21) Appl. No.: **29/495,949**

(22) Filed: **Jul. 8, 2014**

(30) **Foreign Application Priority Data**

May 1, 2014 (JP) 2014-009583

(51) **LOC (10) Cl.** **23-01**

(52) **U.S. Cl.**
USPC **D23/233**

(58) **Field of Classification Search**
USPC D23/233-237, 244-249; D15/5, 7;
137/15.04, 15.08, 515, 7, 859, 843,
137/332, 529, 533.17, 540, 54, 543.17,
137/512.1; 251/333
CPC F16K 15/00; F16K 15/18; F16K 15/026;
F16K 15/044; B60T 17/04
See application file for complete search history.

(56) **References Cited**

U.S. PATENT DOCUMENTS

D246,908 S * 1/1978 Fetty D23/233
D259,891 S * 7/1981 Ogniewski D23/233
D398,705 S * 9/1998 Tourigny D23/233
D413,374 S * 8/1999 Tine, Jr. D23/233
D413,650 S * 9/1999 Sato et al. D23/233
D415,559 S * 10/1999 Sato et al. D23/233
D504,715 S * 5/2005 Hagihara D23/235
D558,859 S * 1/2008 Kato et al. D23/233

D562,436 S * 2/2008 Kato et al. D23/233
D563,514 S * 3/2008 Mita et al. D23/233
D603,016 S * 10/2009 Matsumura D23/233
D609,307 S * 2/2010 Moriyama D23/233
D610,652 S * 2/2010 Ben-Nun D23/233

(Continued)

Primary Examiner — Cynthia Ramirez

(74) *Attorney, Agent, or Firm* — Yokoi & Co., U.S.A.;
Toshiyuki Yokoi

(57) **CLAIM**

The ornamental design for an electromagnetic valve, as shown and described.

DESCRIPTION

FIG. 1 shows a front view of an electromagnetic valve showing our new design;
FIG. 2 shows a rear view thereof;
FIG. 3 shows a right side view thereof;
FIG. 4 shows a left side view thereof;
FIG. 5 shows a top view thereof;
FIG. 6 shows a bottom view thereof; and,
FIG. 7 shows a top, front and right side perspective view thereof.

The portions of the design shown in broken lines in FIG. 6 are for the purpose of illustrating the environment only and form no part of the claimed design.

The present article is an electromagnetic valve used for controlling an operation of fluid pressure devices such as a fluid pressure cylinder by connecting or shutting off pressure fluid supplied to the fluid pressure devices. The electromagnetic valve has a body portion that houses a not illustrated valve body and a cover portion that is continuously provided at an upper part of the body portion. At both ends in a longitudinal direction of the body portion, a port for introducing the fluid and a port for deriving the fluid are provided. Inside the cover portion, a plunger (moving core) and a solenoid coil are housed. Lead wires are provided for supplying electricity and receiving control signals. When using the electromagnetic valve, the plunger is displaced by supplying or cutting off the electricity to the solenoid coil. If the plunger is displaced, the ports are connected or shut off and therefore a flow state of the pressure fluid is switched.

1 Claim, 6 Drawing Sheets

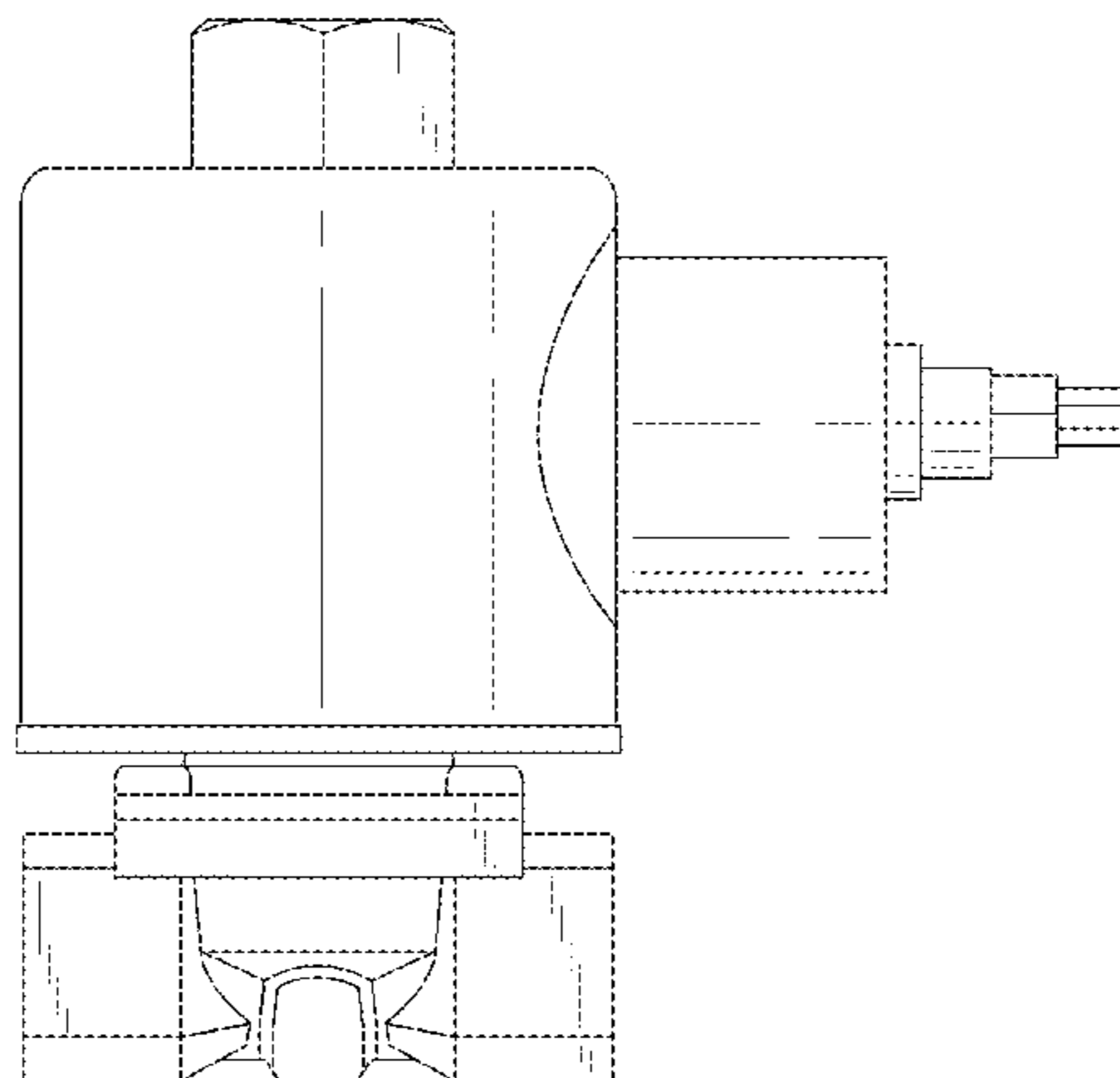

(56)

References Cited

U.S. PATENT DOCUMENTS

D615,618 S * 5/2010 Someya D23/233
D632,362 S * 2/2011 Ito et al. D23/233
D633,986 S * 3/2011 Ito et al. D23/233
D676,110 S * 2/2013 Oike et al. D23/233
D677,363 S * 3/2013 Norlander et al. D23/233

D692,983 S * 11/2013 Nissen et al. D23/233
D693,429 S * 11/2013 Thibodeaux, Jr. D23/233
D698,899 S * 2/2014 Narita D23/233
D706,392 S * 6/2014 Oike D23/233
D712,513 S * 9/2014 Kainuma et al. D23/233
D720,430 S * 12/2014 Yoshida et al. D23/233
D722,674 S * 2/2015 Lipkens et al. D23/207
2009/0272194 A1* 11/2009 Weingarten 73/700

* cited by examiner

FIG. 1

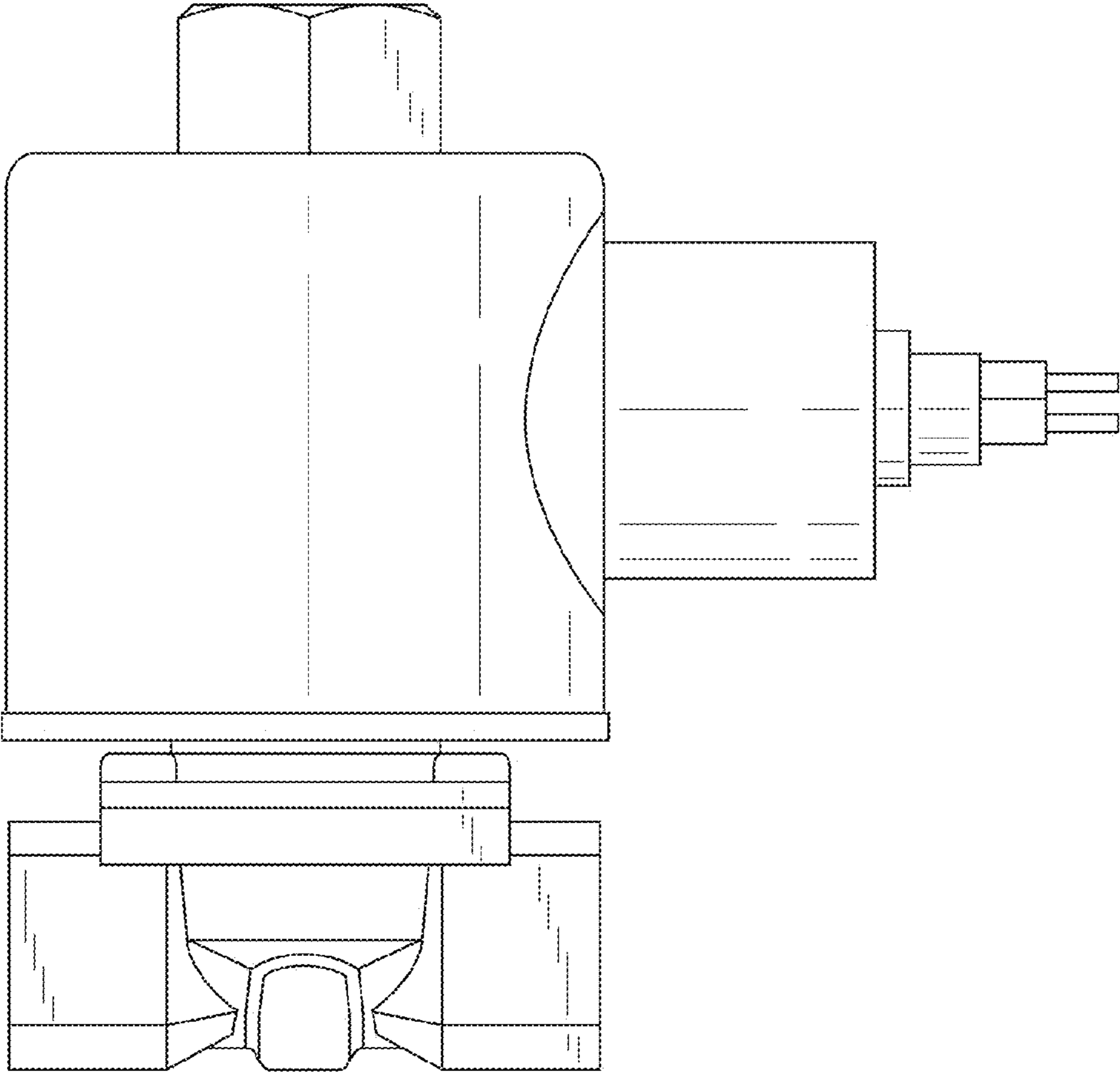

FIG. 2

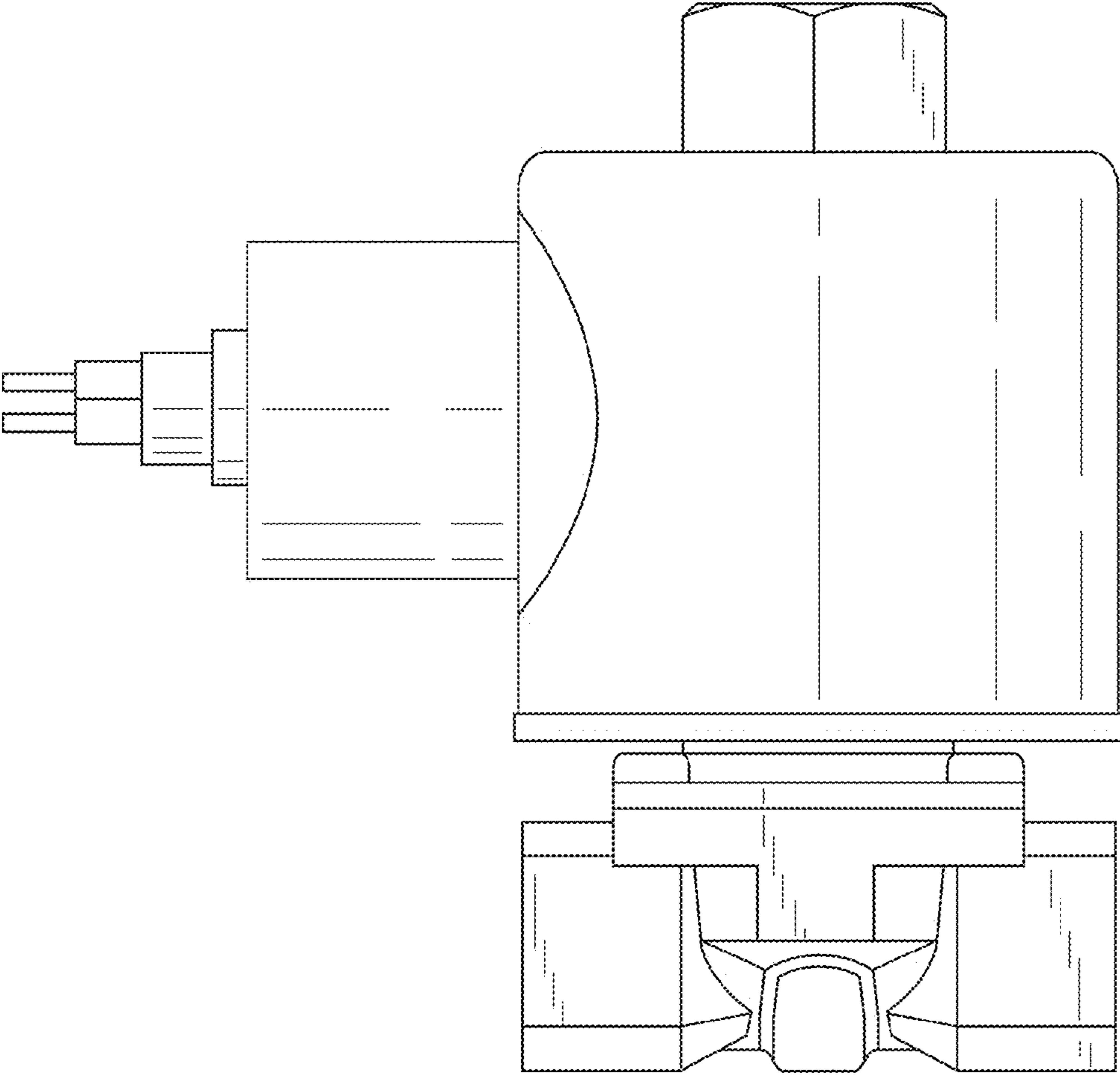

FIG. 3

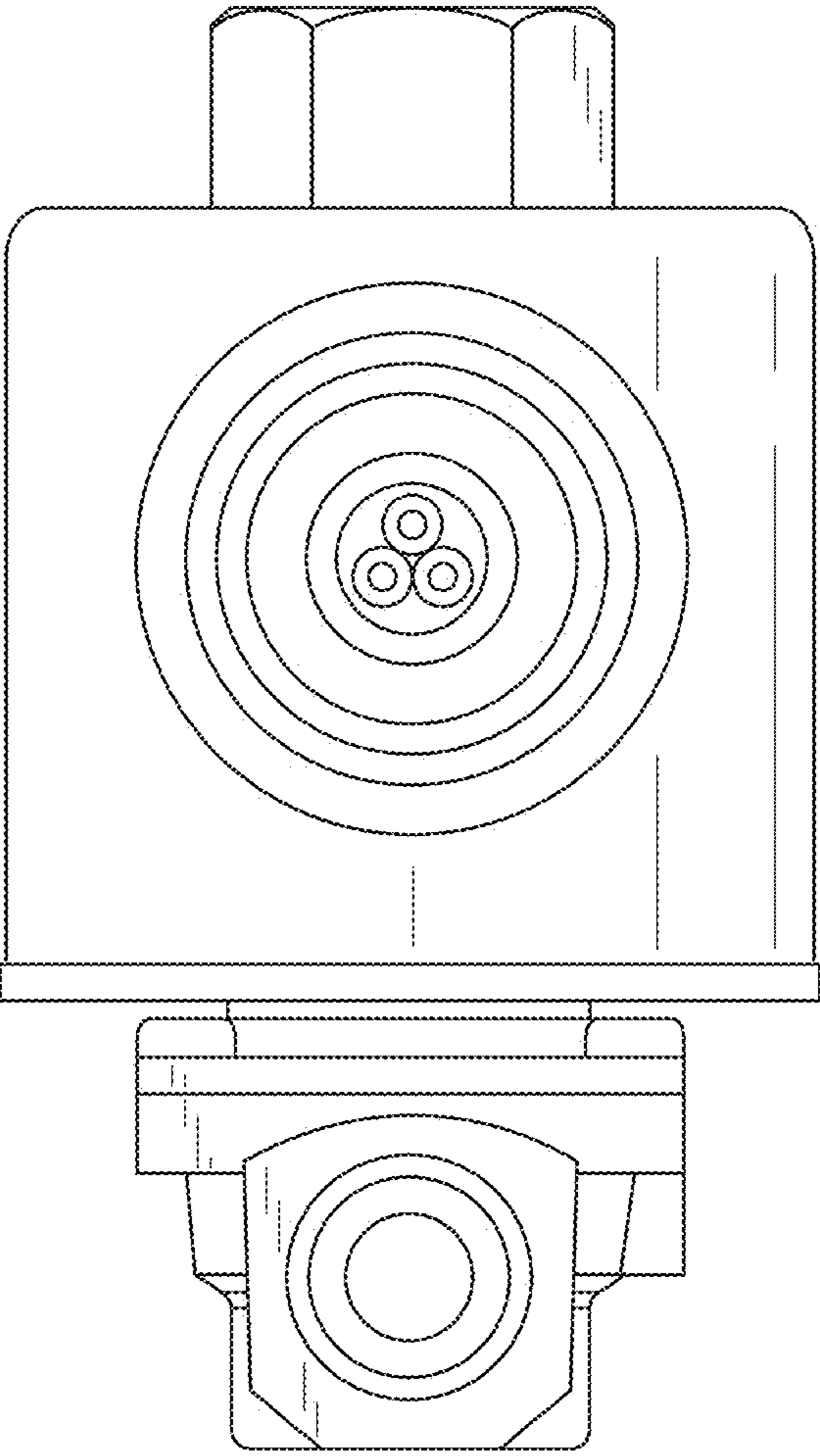

FIG. 4

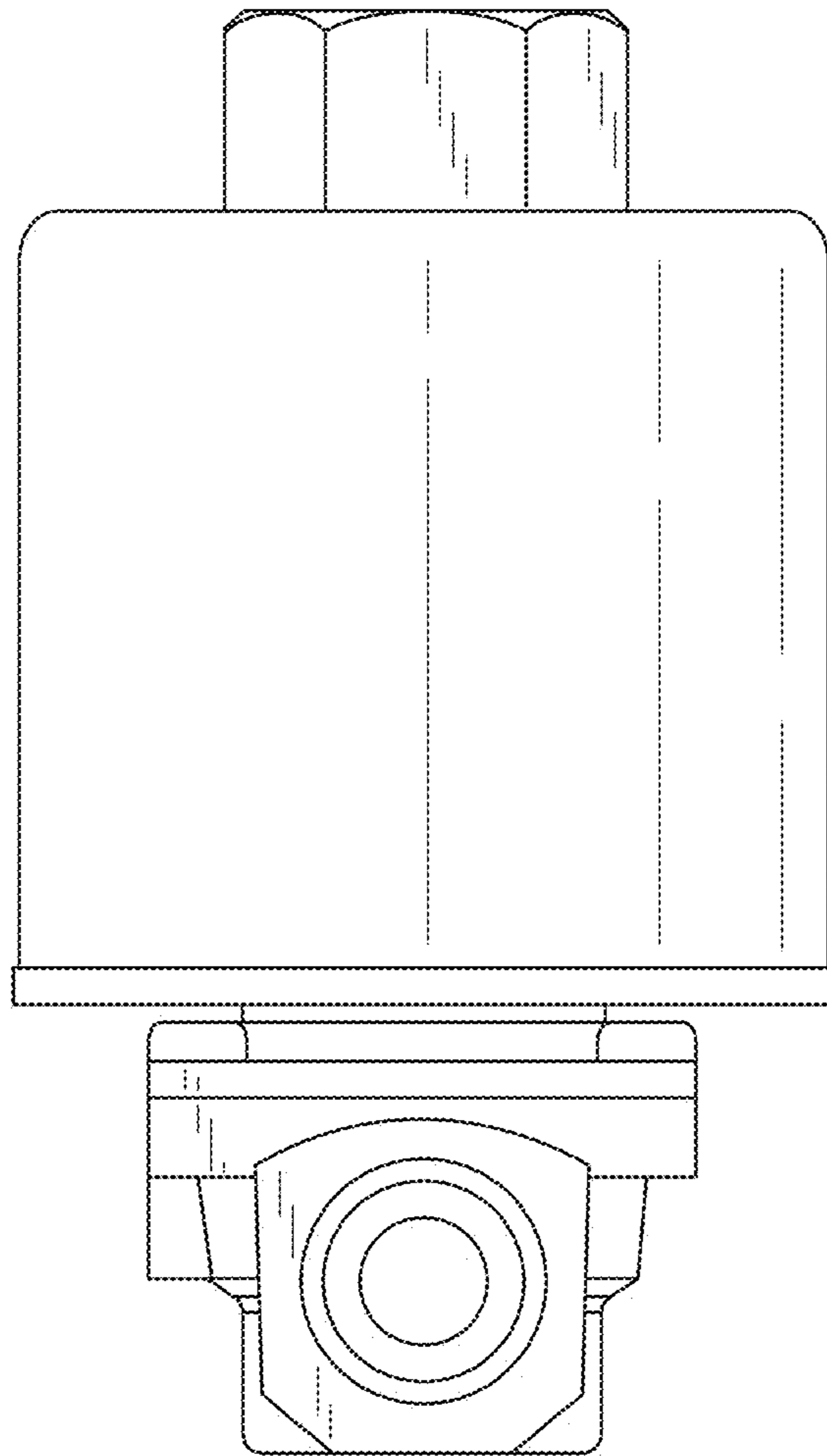

FIG. 5

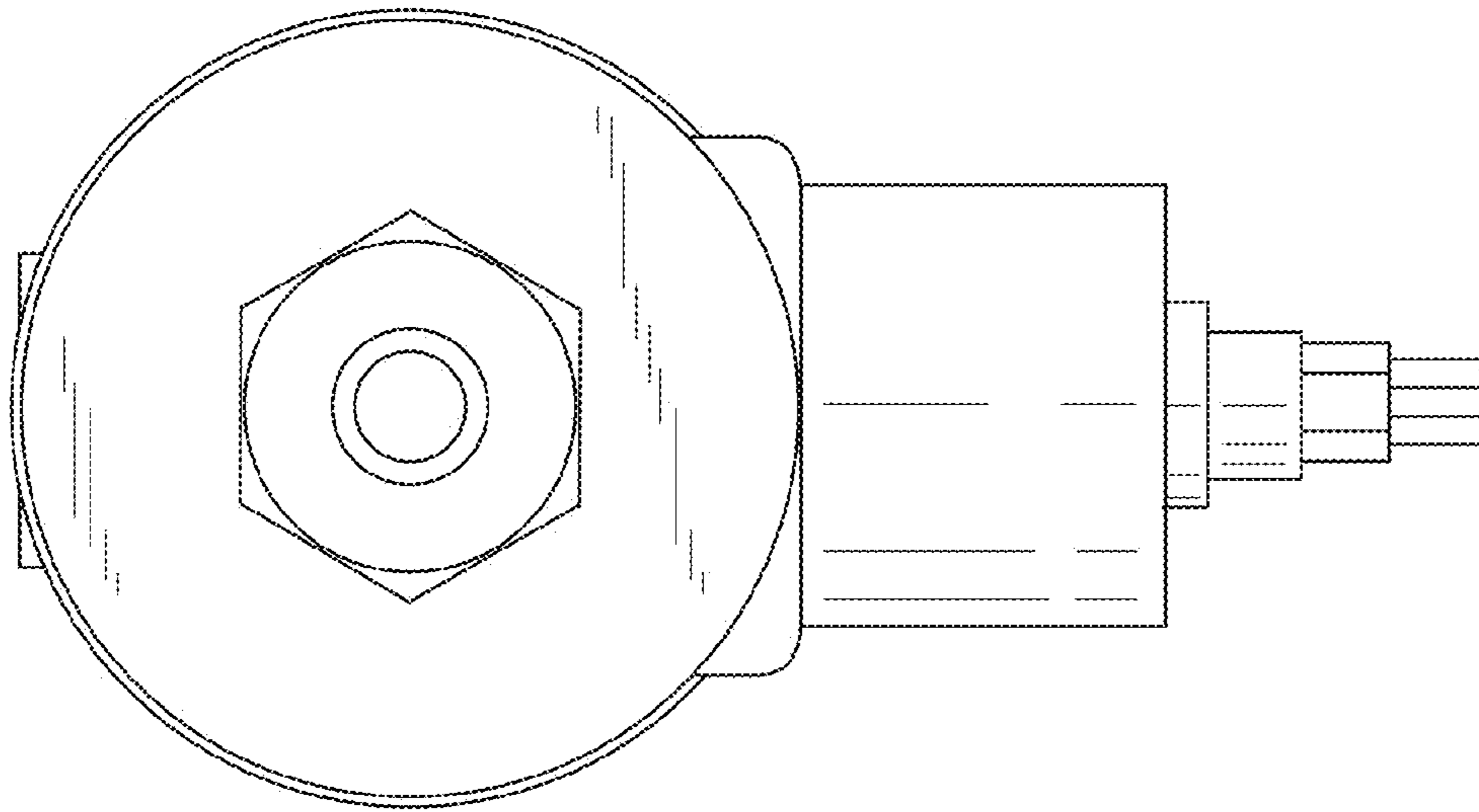

FIG. 6

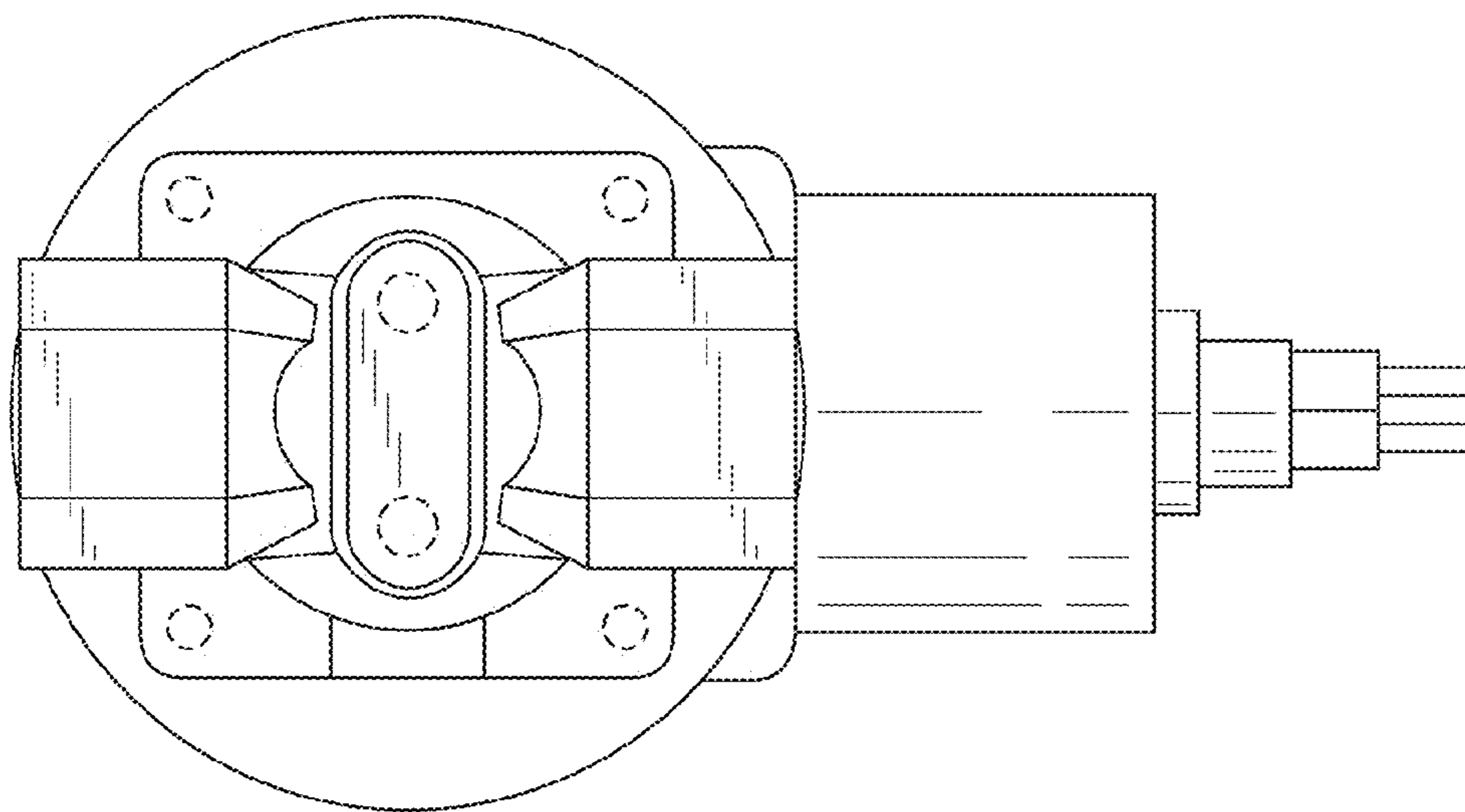

FIG. 7

