



US00D738180S

(12) **United States Design Patent**
Campbell

(10) **Patent No.:** **US D738,180 S**

(45) **Date of Patent:** **** Sep. 8, 2015**

(54) **COMBINATION FASTENER AND MATING DRIVING TOOL**

(71) Applicant: **Bryce Fastener Company, Inc**, Gilbert, AZ (US)

(72) Inventor: **Richard Bryce Campbell**, Gilbert, AZ (US)

(73) Assignee: **Bryce Fastener, Inc.**, Gilbert, AZ (US)

(**) Term: **14 Years**

(21) Appl. No.: **29/465,322**

(22) Filed: **Aug. 27, 2013**

Related U.S. Application Data

(63) Continuation of application No. 13/891,521, filed on May 10, 2013.

(51) **LOC (10) Cl.** **08-04**

(52) **U.S. Cl.**
USPC **D8/86**

(58) **Field of Classification Search**

USPC D8/70, 82, 85-87, 105; D15/139; 81/121.1, 436, 451-452, 460-461; 411/1-3, 393, 395, 402-404, 407
CPC A61B 17/8615; A61B 17/862; A61B 17/888; A61B 17/8891; B21K 1/463; B21K 1/56; B23P 15/00; B25B 13/065; B25B 13/485; B25B 15/004; B25B 15/005; B25B 15/007; B25B 15/008; B25B 23/101; B25B 23/106; B25B 23/108; F16B 23/0007; F16B 23/0015; F16B 23/003; F16B 23/0038; F16B 23/0053; F16B 23/0061; F16B 23/0069; F16B 23/0076; F16B 23/092; F16B 35/00; F16D 1/06; F16D 3/20

See application file for complete search history.

(56) **References Cited**

U.S. PATENT DOCUMENTS

3,658,105 A * 4/1972 Burt et al. 81/460
3,872,904 A * 3/1975 Barlow 81/460
4,269,246 A * 5/1981 Larson et al. 81/460

(Continued)

Primary Examiner — Philip S Hyder

Assistant Examiner — Roselynn Cody

(74) *Attorney, Agent, or Firm* — The Noblitt Group, PLLC

(57) **CLAIM**

The ornamental design for a combination fastener and mating driving tool, as shown and described.

DESCRIPTION

FIG. 1 is a perspective view of a first embodiment of the combination fastener and mating driving tool wherein the fastener has six recessed receiving areas and the drive tool has six fins;

FIG. 2 is a bottom view of the fastener shown in FIG. 1;

FIG. 3 is a top view thereof showing six receiving areas;

FIG. 4 is a side view thereof;

FIG. 5 is a cross-sectional view thereof along line 5-5 of FIG. 3;

FIG. 6 is a perspective view of the driving tool shown in FIG. 1;

FIG. 7 is a top view thereof;

FIG. 8 is a bottom view thereof showing six fins;

FIG. 9 is a perspective view of a second embodiment of the combination fastener and mating driving tool wherein the fastener has seven recessed receiving areas and the drive tool has seven fins;

FIG. 10 is a top view of the fastener shown in FIG. 9 having seven receiving areas; and,

FIG. 11 is a bottom view of the driving tool shown in FIG. 9 having seven fins.

The broken lines in the drawings are directed to portions of the combination fastener and mating driving tool that form no part of the claim.

1 Claim, 6 Drawing Sheets

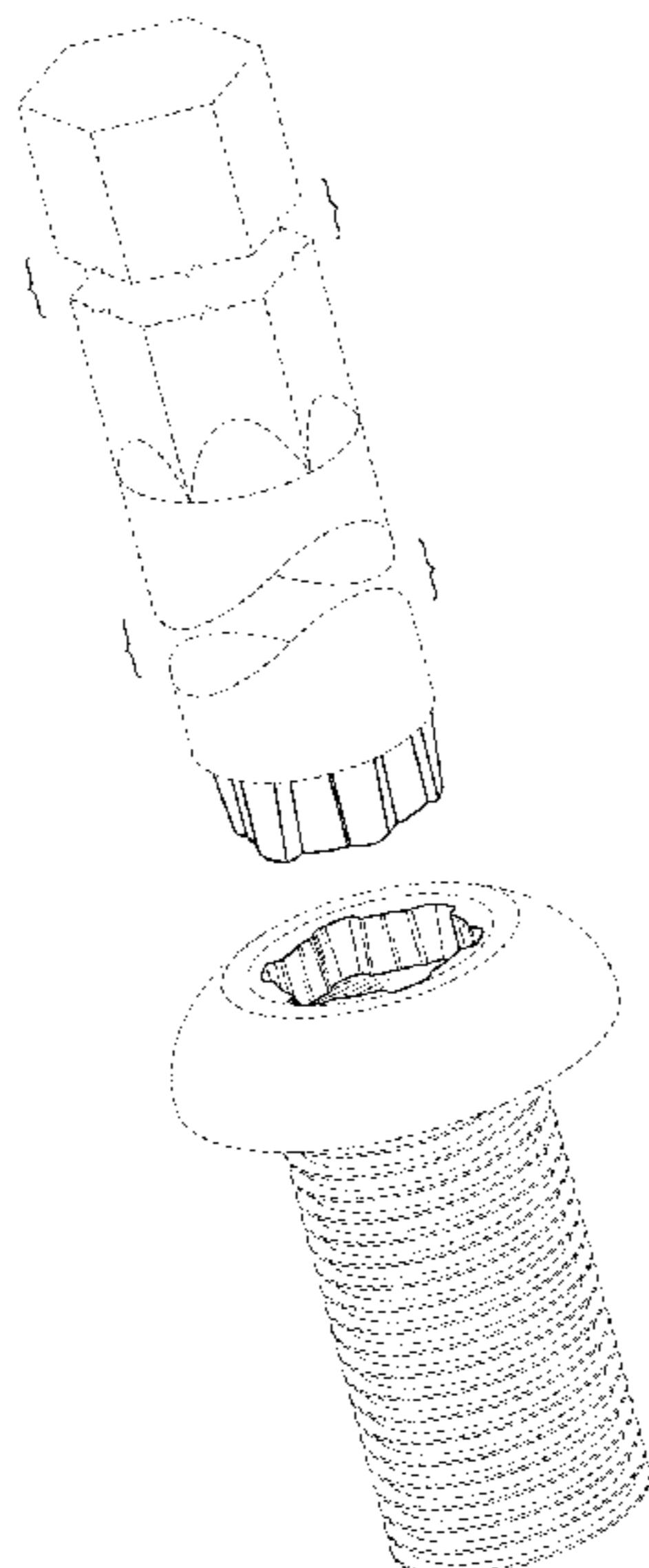

(56)

References Cited

U.S. PATENT DOCUMENTS

5,207,132	A *	5/1993	Goss et al.	81/460	7,311,026	B2 *	12/2007	Melton	81/436
5,214,987	A *	6/1993	Fenton, Sr.	81/460	7,730,812	B2 *	6/2010	Edland	81/460
5,291,811	A *	3/1994	Goss	81/460	D660,672	S *	5/2012	Davis	D8/86
5,353,667	A *	10/1994	Wilner	81/436	8,291,795	B2 *	10/2012	Hughes et al.	81/460
5,598,753	A *	2/1997	Lee	81/460	8,459,155	B2 *	6/2013	Canizares et al.	81/451
5,868,049	A *	2/1999	Kanwal	81/460	8,739,660	B2 *	6/2014	Edland et al.	81/460
6,367,358	B1 *	4/2002	Stacy	81/436	2011/0283843	A1 *	11/2011	Werner et al.	81/461
7,073,416	B2 *	7/2006	Kozak et al.	81/460	2012/0137842	A1 *	6/2012	Guo et al.	81/460
7,225,710	B2 *	6/2007	Pacheco, Jr.	81/460	2012/0312130	A1 *	12/2012	Bauer	81/461
					2013/0068075	A1 *	3/2013	Stiebitz et al.	81/460
					2014/0331826	A1 *	11/2014	Campbell	81/436

* cited by examiner

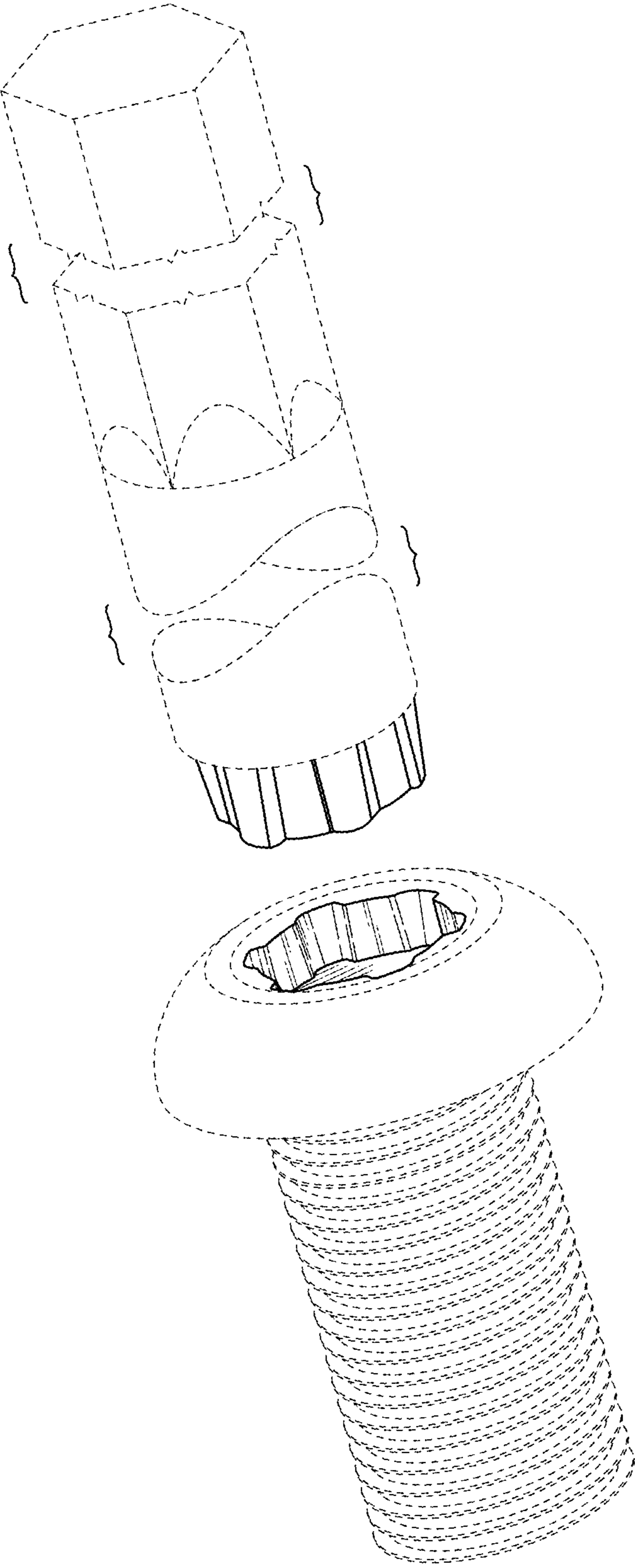

FIGURE 1

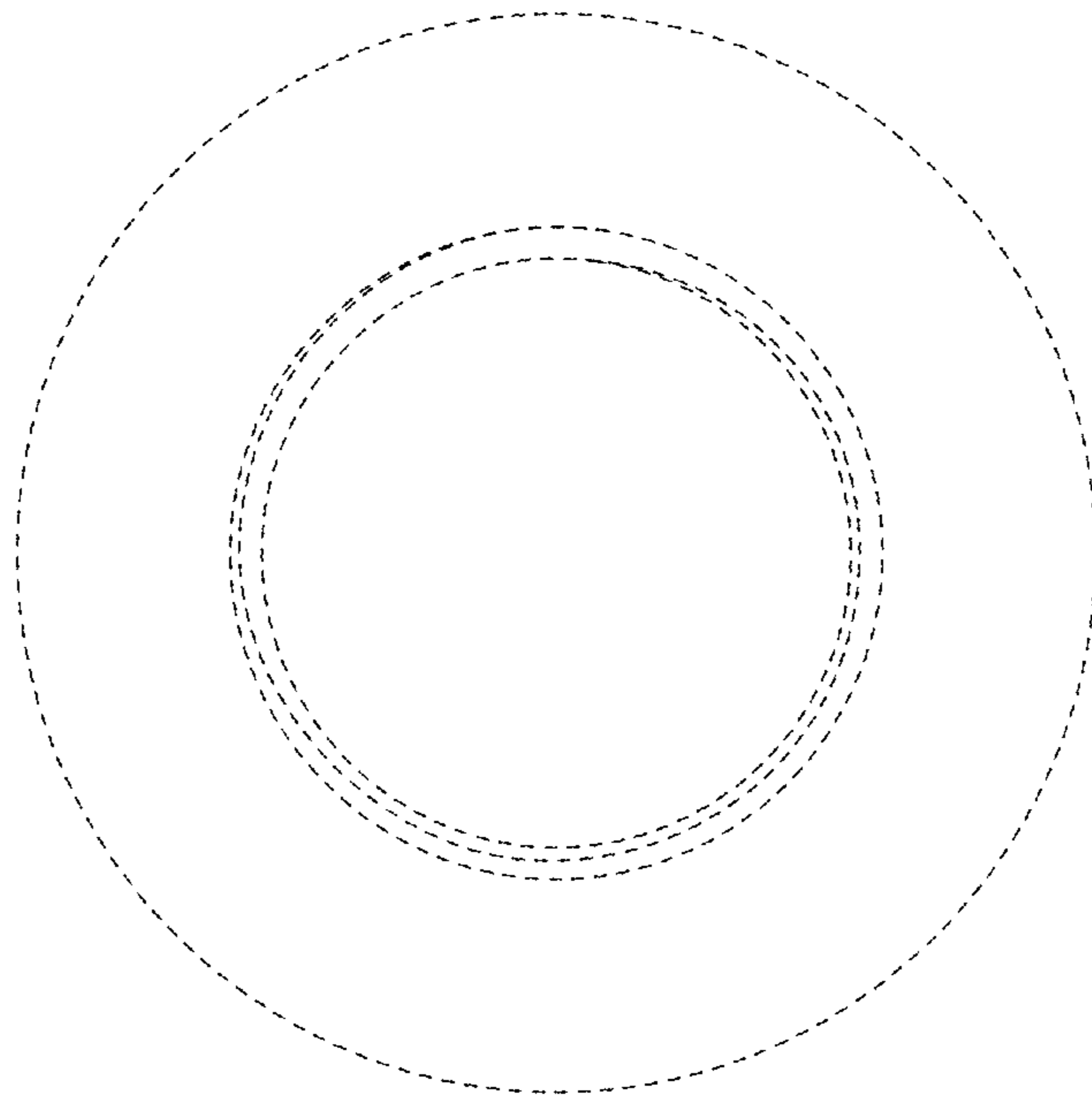

FIGURE 2

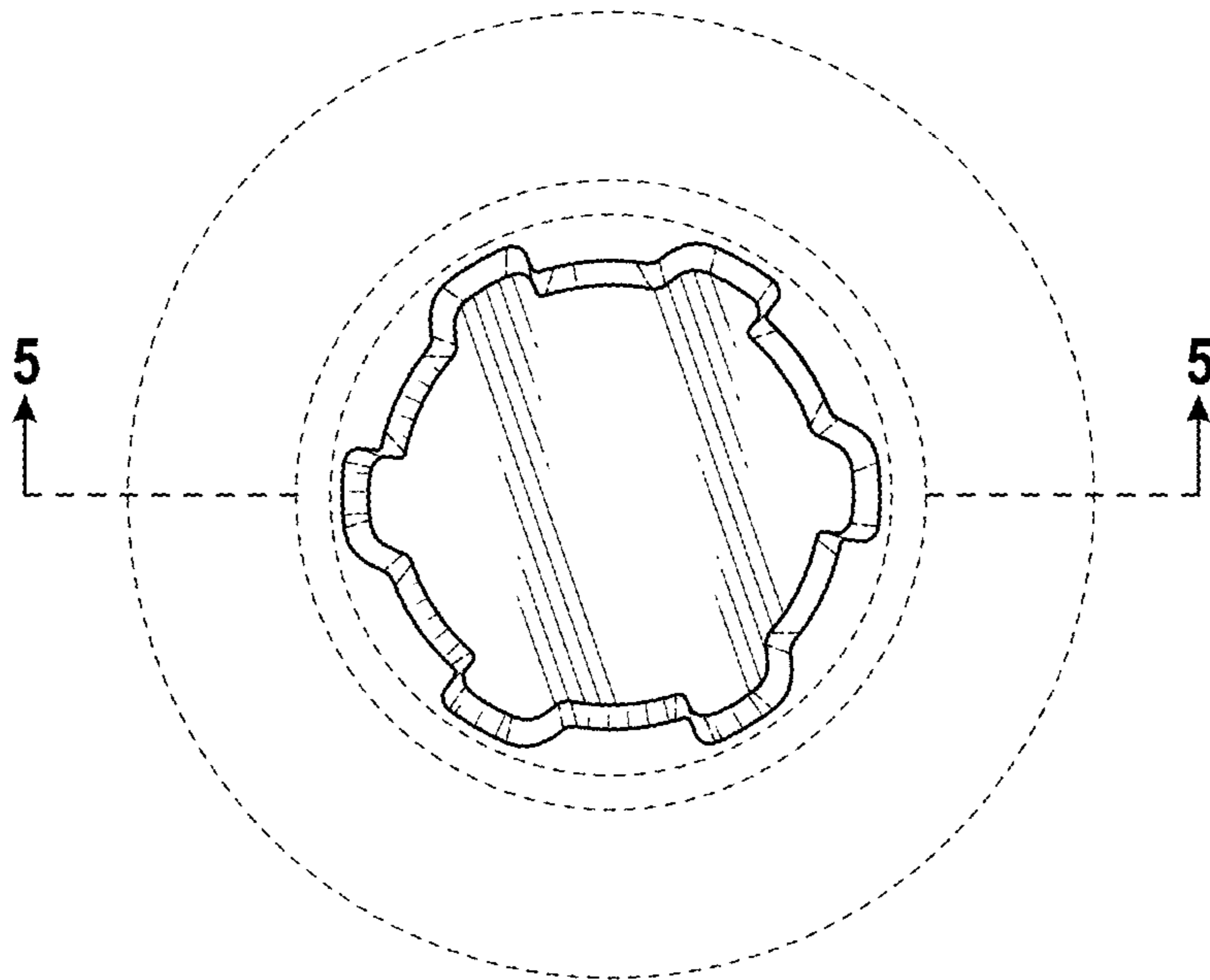

FIGURE 3

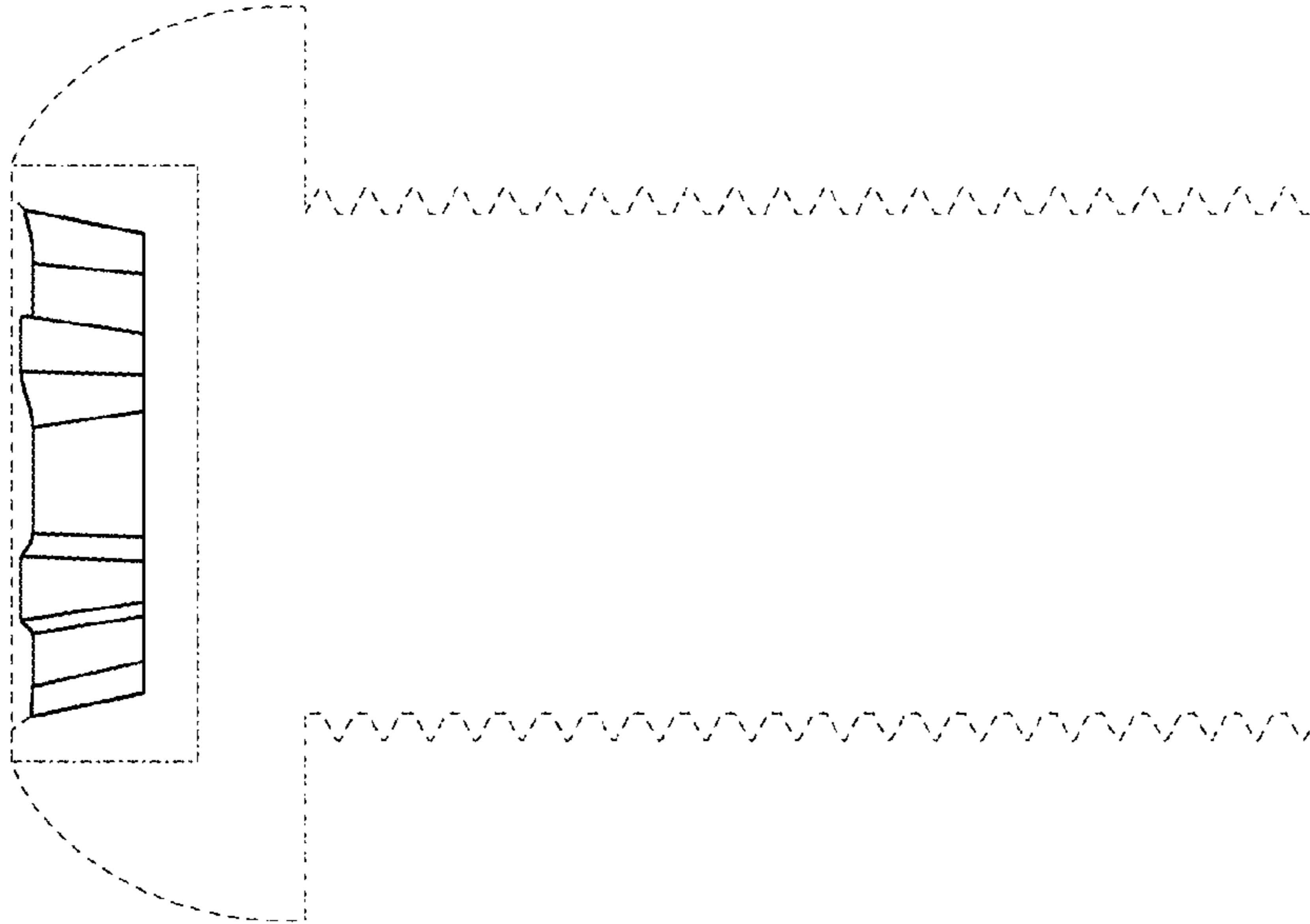

FIGURE 5

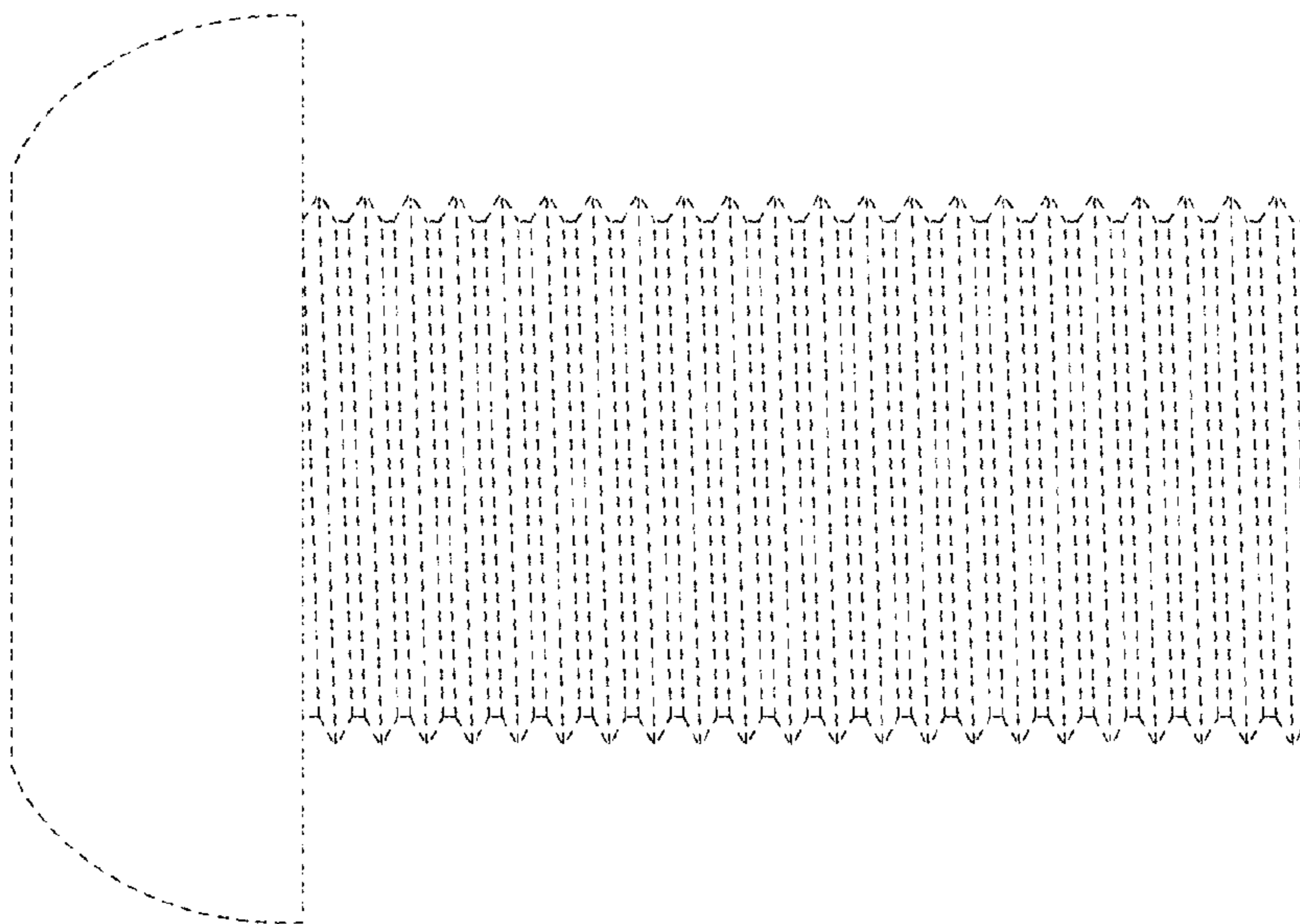

FIGURE 4

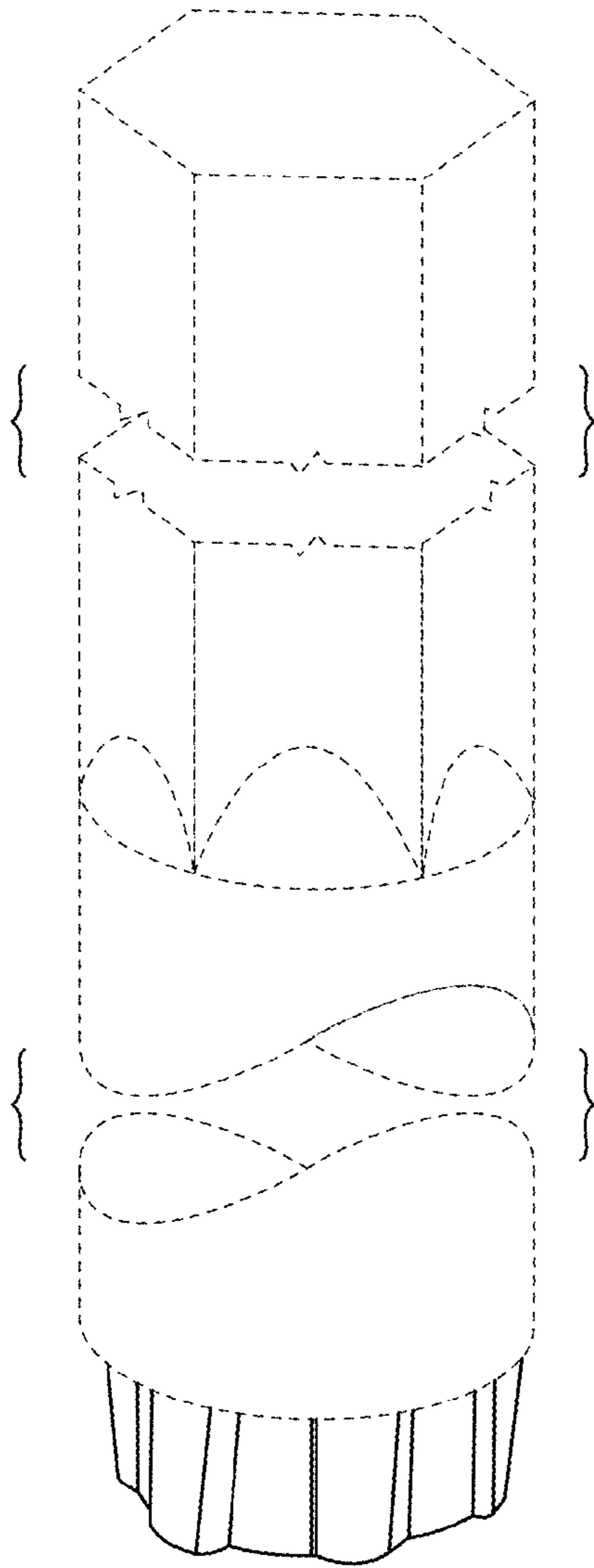

FIGURE 6

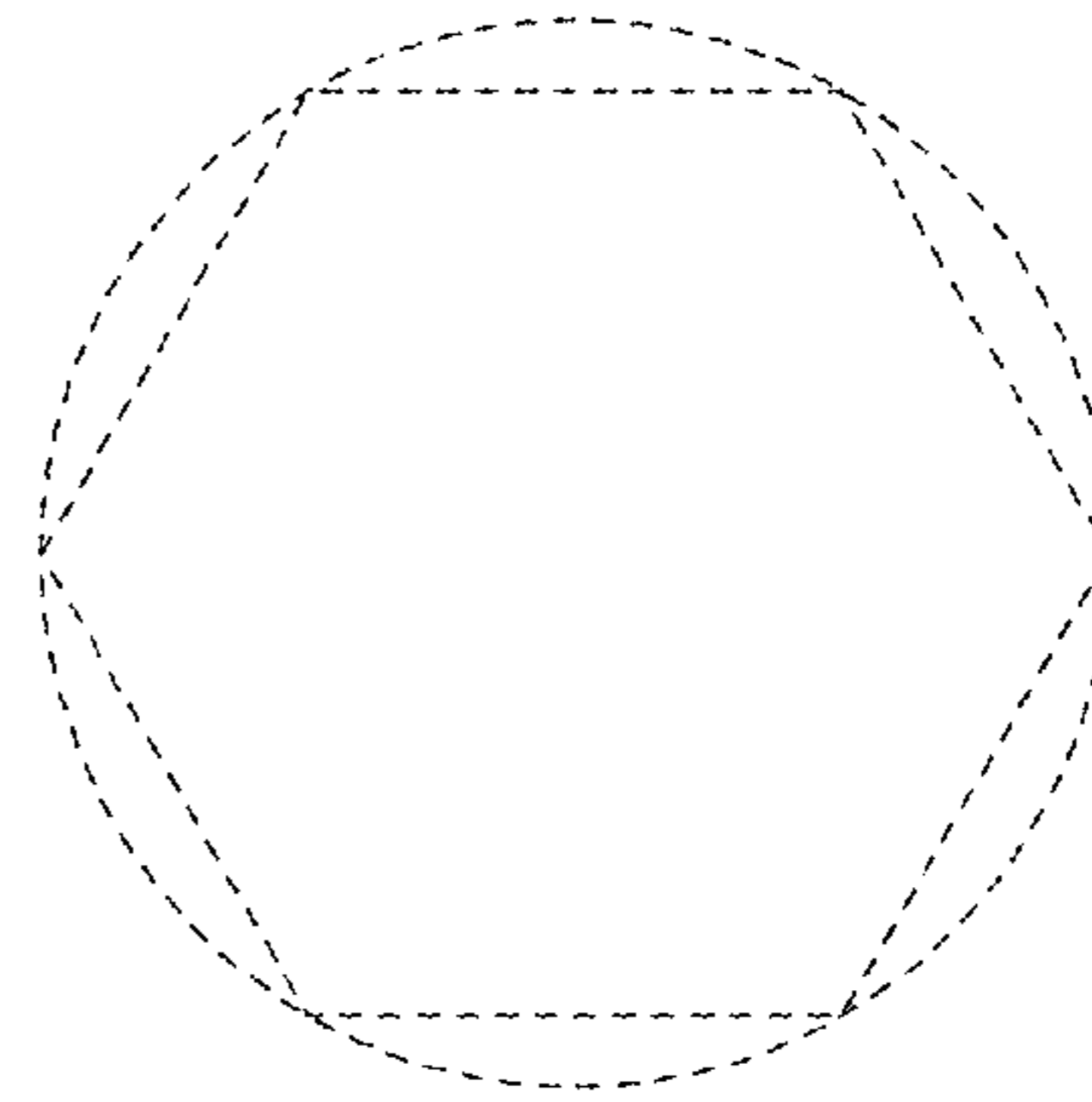

FIGURE 7

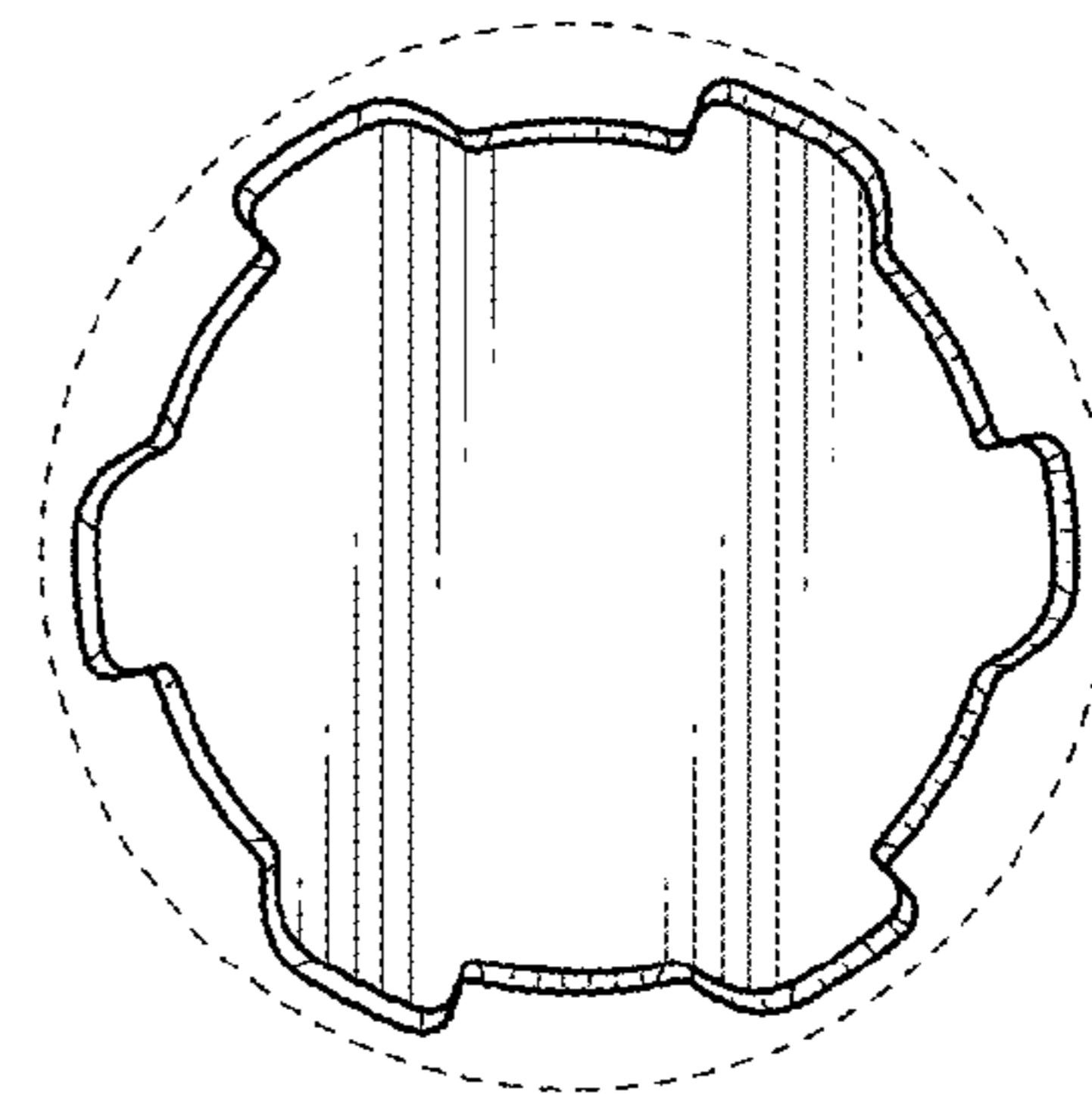

FIGURE 8

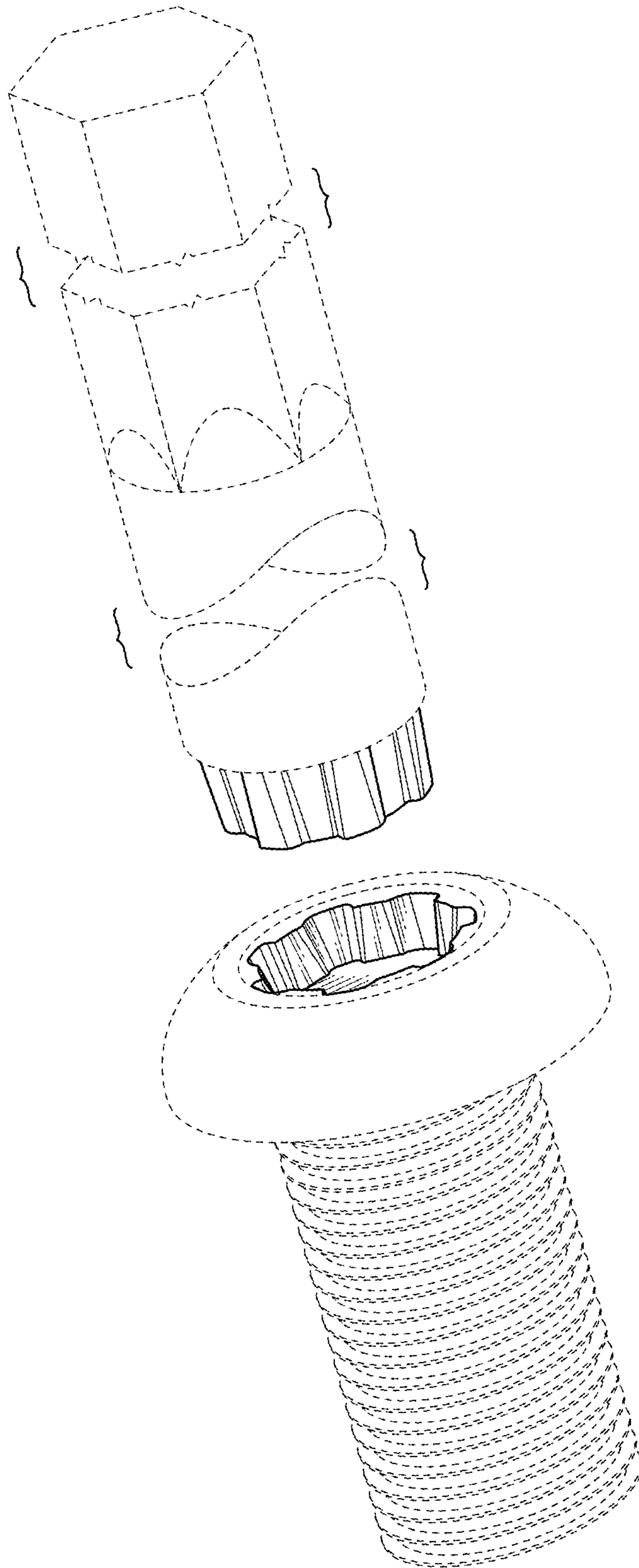

FIGURE 9

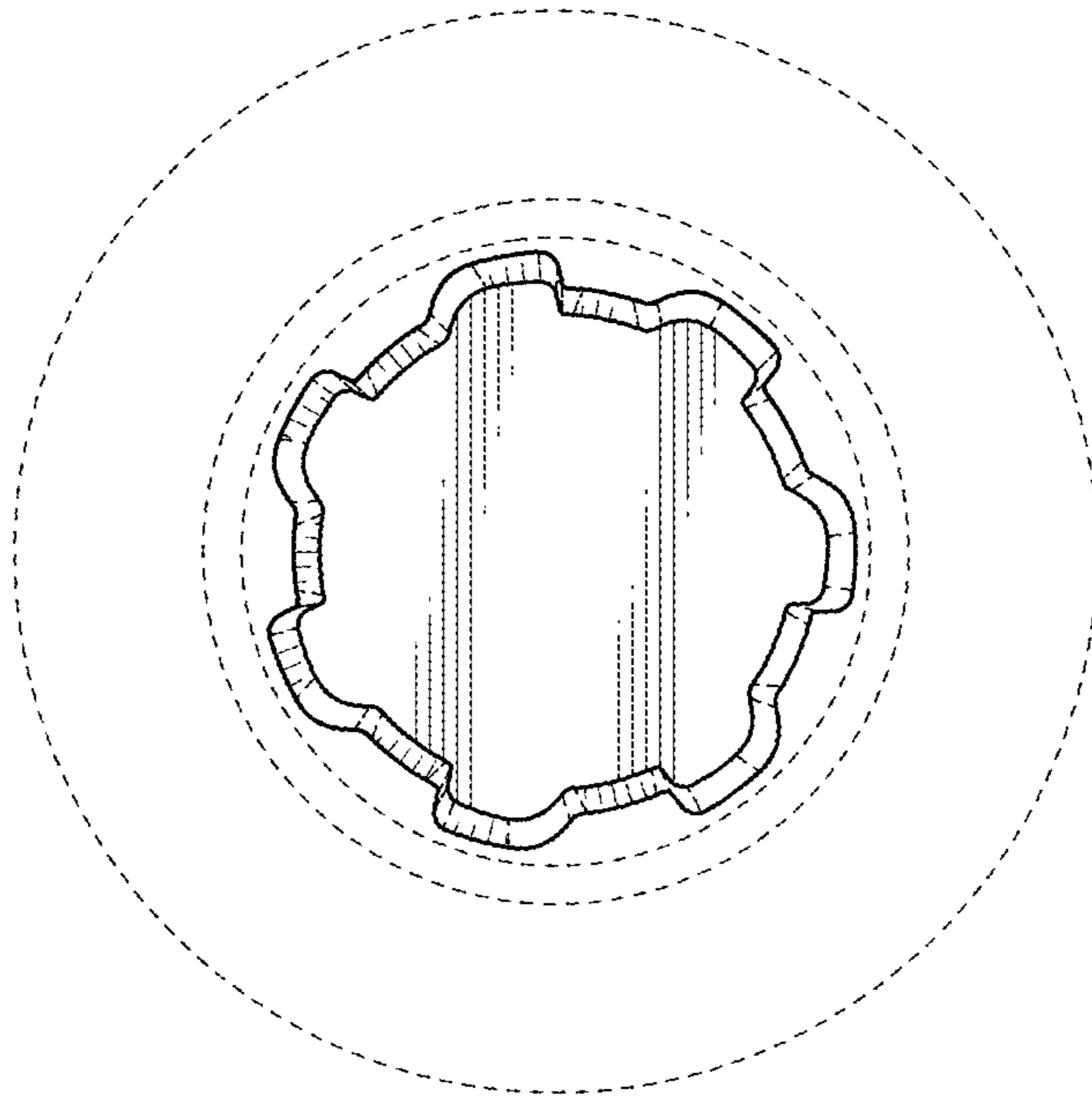

FIGURE 10

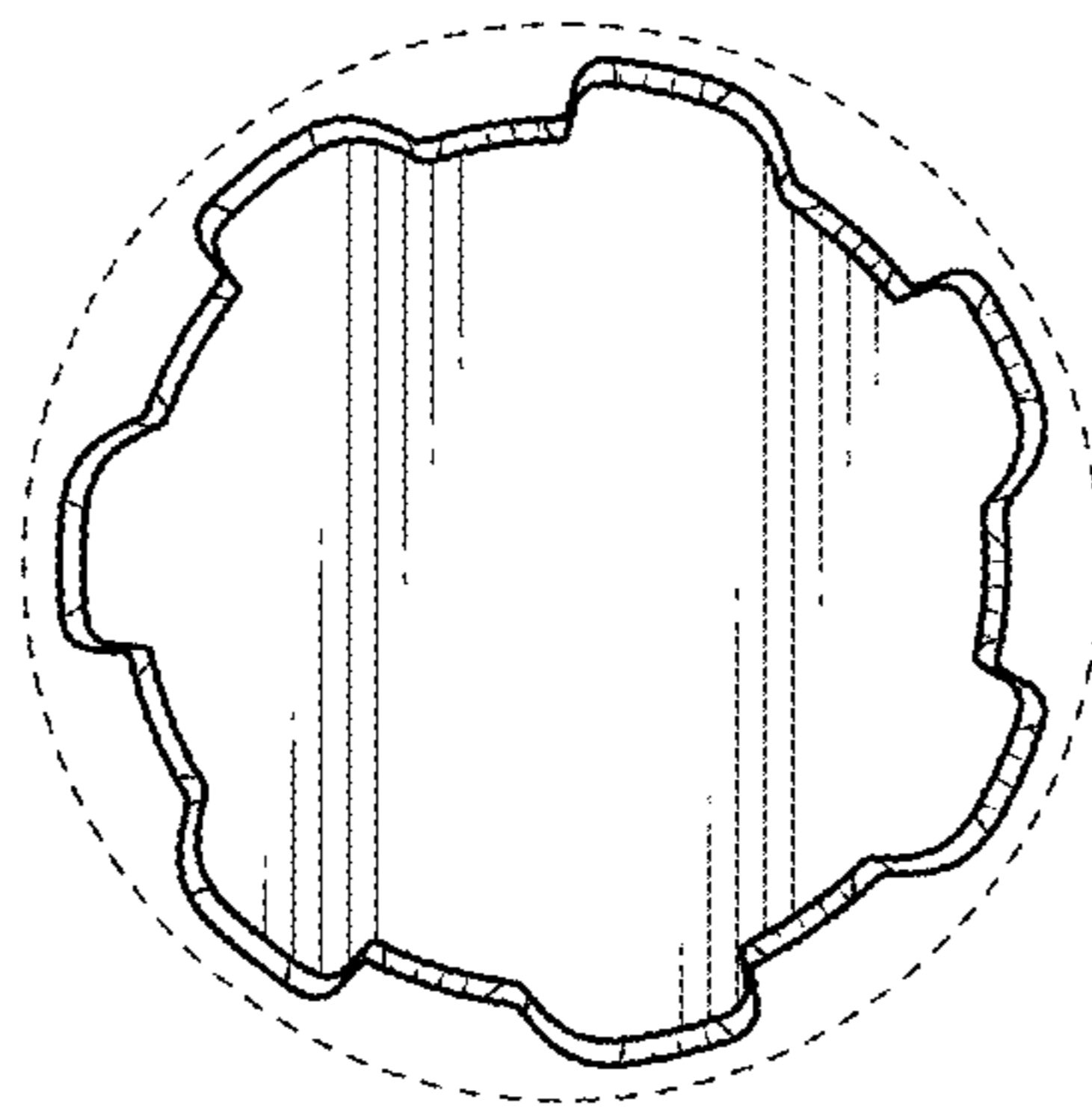

FIGURE 11