



US00D738145S

(12) **United States Design Patent**  
**Danford et al.**

(10) **Patent No.:** **US D738,145 S**  
(45) **Date of Patent:** **\*\* Sep. 8, 2015**

(54) **GUITAR STAND**

(71) Applicants: **Casey Danford**, Cadillac, MI (US); **Dan Tunis Danford**, Cadillac, MI (US)

(72) Inventors: **Casey Danford**, Cadillac, MI (US); **Dan Tunis Danford**, Cadillac, MI (US)

(\*\*) Term: **14 Years**

(21) Appl. No.: **29/506,896**

(22) Filed: **Oct. 21, 2014**

(51) **LOC (10) Cl.** ..... **06-06**

(52) **U.S. Cl.**  
USPC ..... **D6/682.3**

(58) **Field of Classification Search**  
USPC ..... D6/672-673, 678, 680, 682, 682.3;  
D17/9, 20; D14/229, 447  
CPC ..... A47F 7/00; A47F 7/0042  
See application file for complete search history.

(56) **References Cited**

**U.S. PATENT DOCUMENTS**

4,215,838	A	8/1980	Gullota	
4,377,268	A	3/1983	Wolford	
5,197,701	A	3/1993	Olson	
6,231,018	B1	5/2001	Barbieri	
7,394,006	B2	7/2008	Bordignon	
7,547,835	B1	6/2009	Mayor	
D596,875	S *	7/2009	Small et al.	..... D6/682
7,777,110	B2	8/2010	Wallis	

D661,309	S *	6/2012	Murrer et al.	..... D14/447
D666,026	S *	8/2012	Alvarez et al.	..... D6/682.3
D668,662	S *	10/2012	Suiter	..... D14/447
D681,626	S *	5/2013	Zehner	..... D14/253
D703,215	S *	4/2014	Alesi et al.	..... D14/447
D705,158	S *	5/2014	Gengler	..... D13/107
D706,784	S *	6/2014	Mills	..... D14/447
D713,182	S *	9/2014	Longacre	..... D6/682
D730,090	S *	5/2015	Christal	..... D6/675.3
D730,888	S *	6/2015	Malsan	..... D14/253
2009/0282963	A1	11/2009	Morrow	
2012/0074270	A1	3/2012	Pays	
2013/0206932	A1	8/2013	Henry	
2013/0292524	A1	11/2013	Canivell Grifols et al.	
2014/0151527	A1	6/2014	Sawhney et al.	

\* cited by examiner

*Primary Examiner* — Kelley Donnelly

(74) *Attorney, Agent, or Firm* — Greenberg Traurig, LLP

(57) **CLAIM**

An ornamental design for a guitar stand, as shown and described.

**DESCRIPTION**

FIG. 1 is a top perspective view of a guitar stand showing our new design;

FIG. 2 is a front elevational view thereof;

FIG. 3 is a rear elevational view thereof;

FIG. 4 is a left side elevational view thereof;

FIG. 5 is right side elevational view thereof;

FIG. 6 is a top plan view thereof; and,

FIG. 7 is a bottom plan view thereof.

**1 Claim, 2 Drawing Sheets**

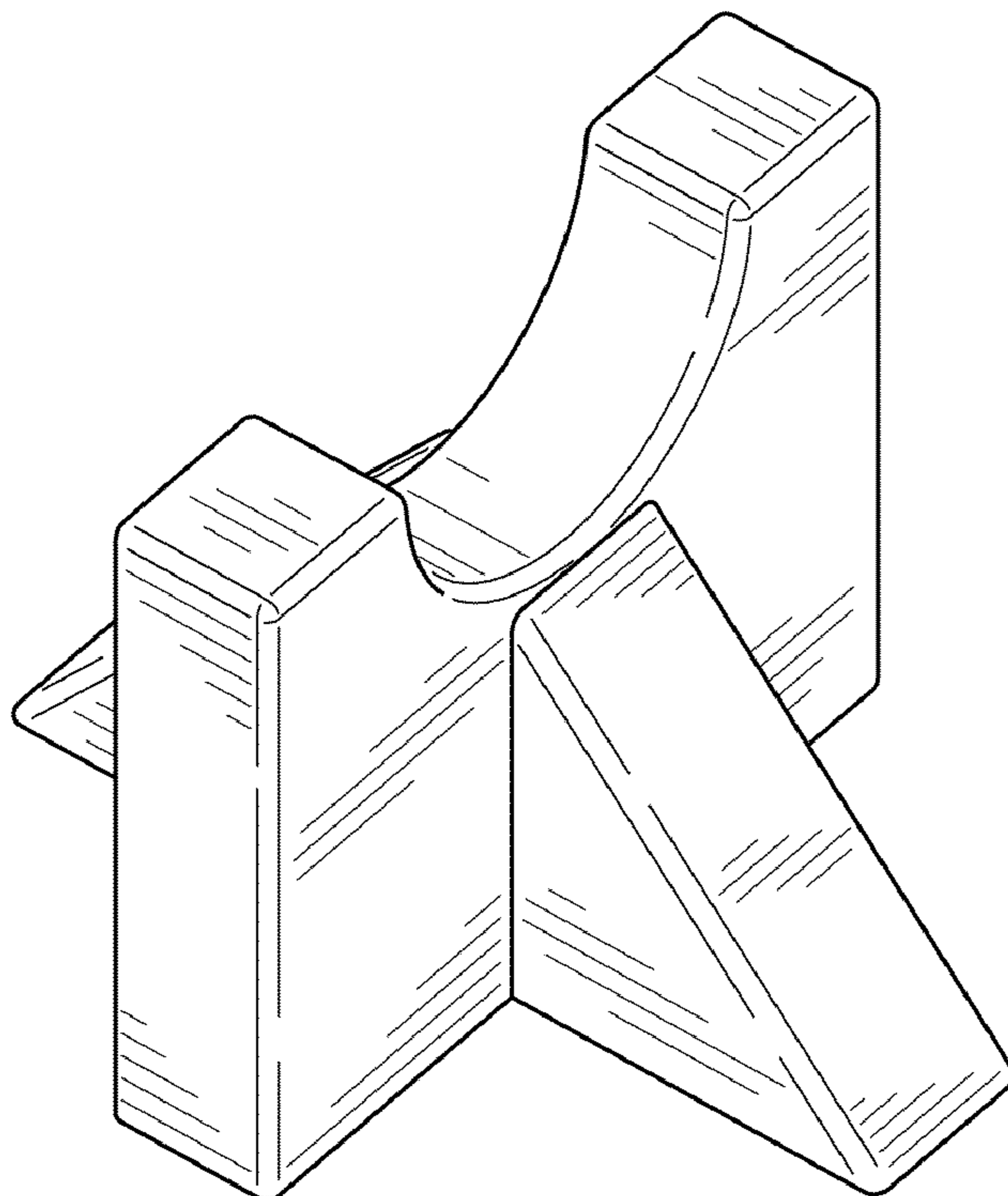

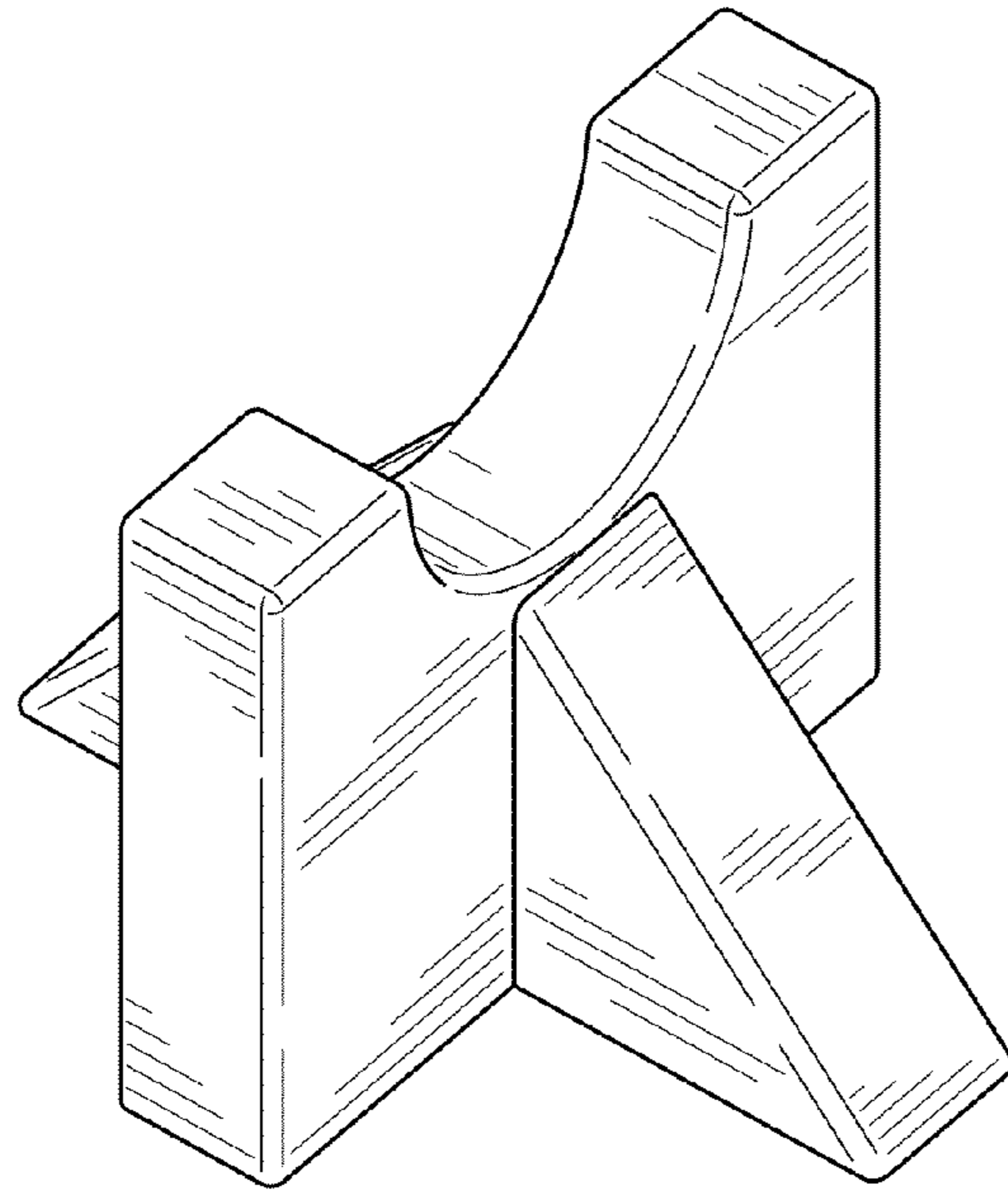

FIG. 1

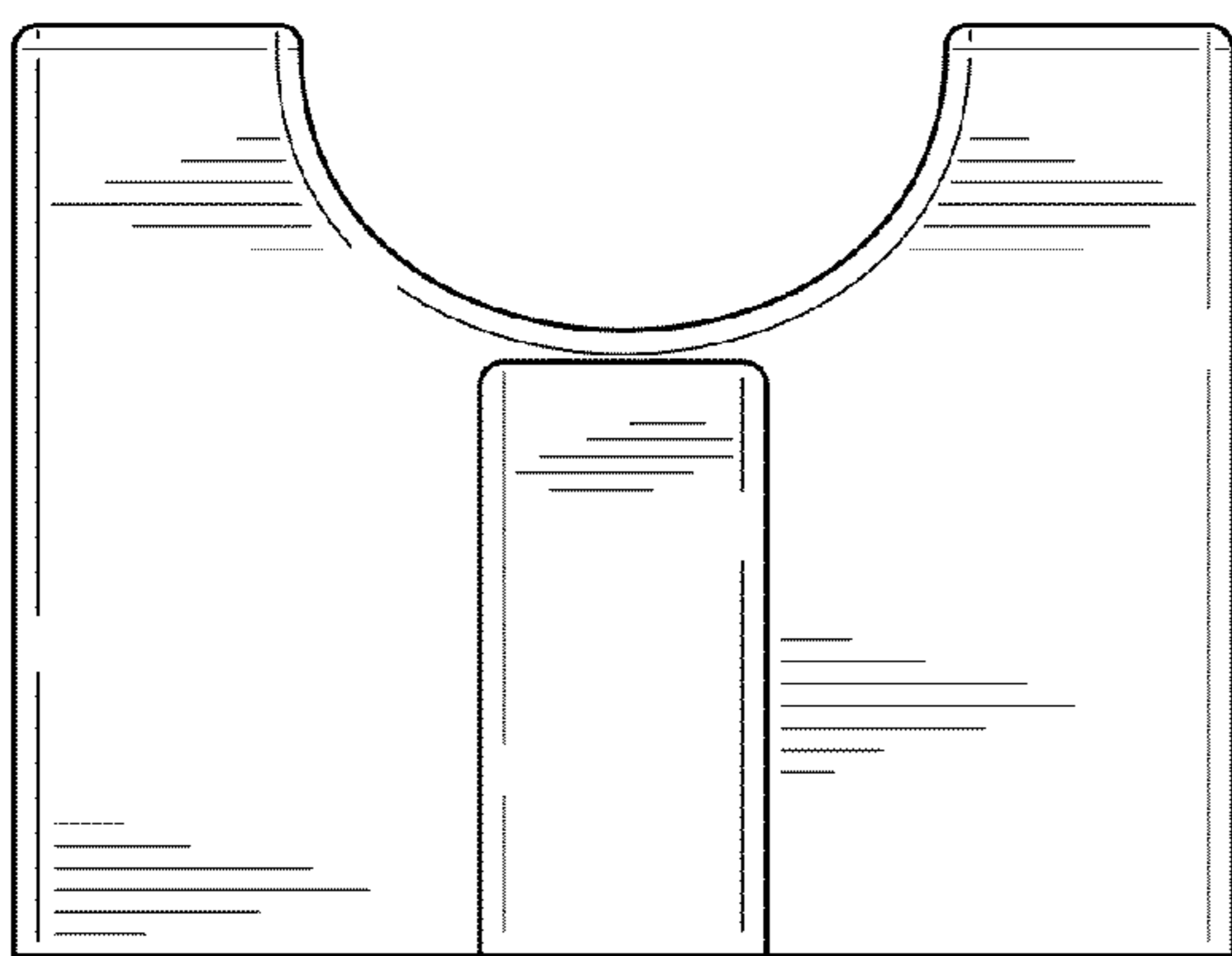

FIG. 2

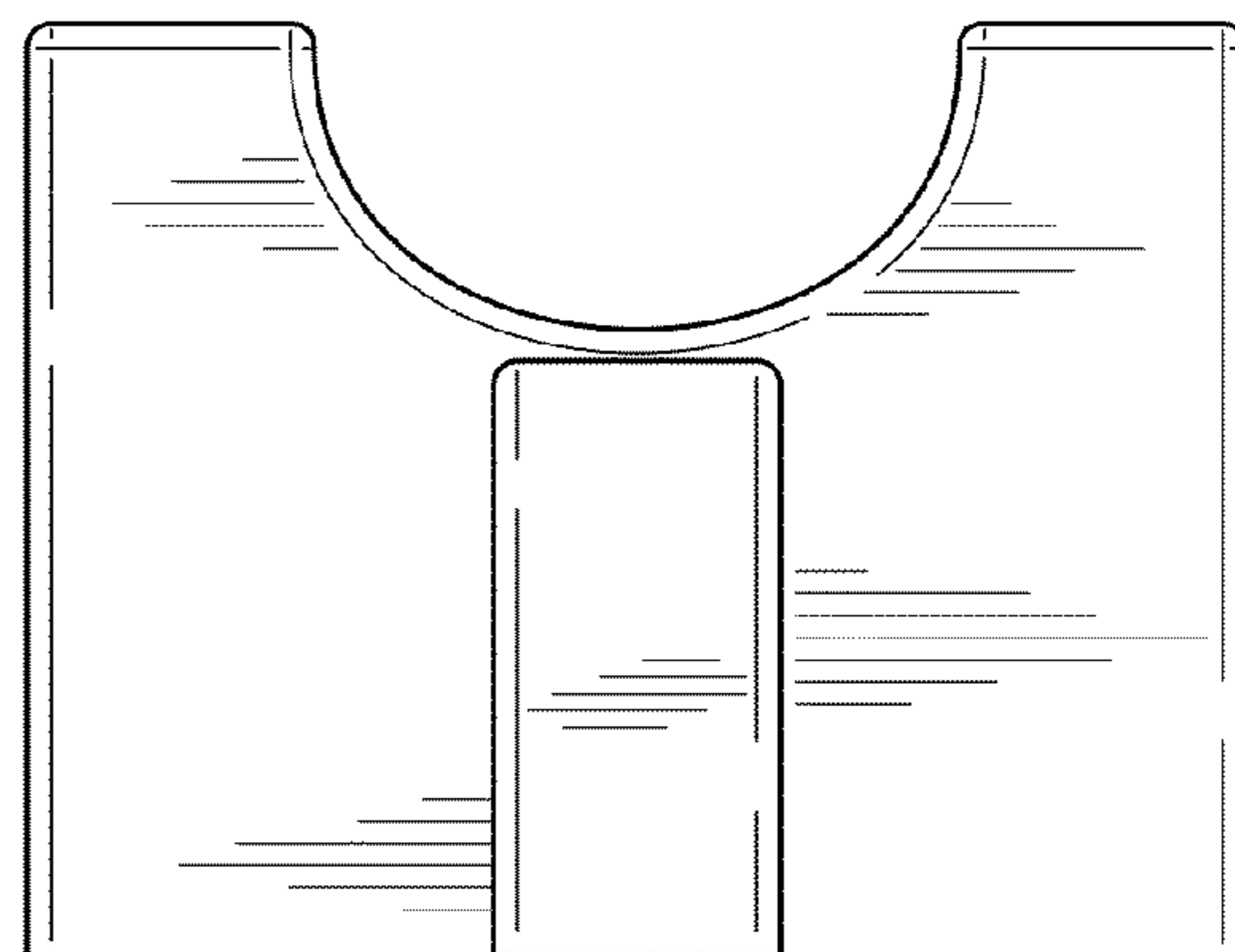

FIG. 3

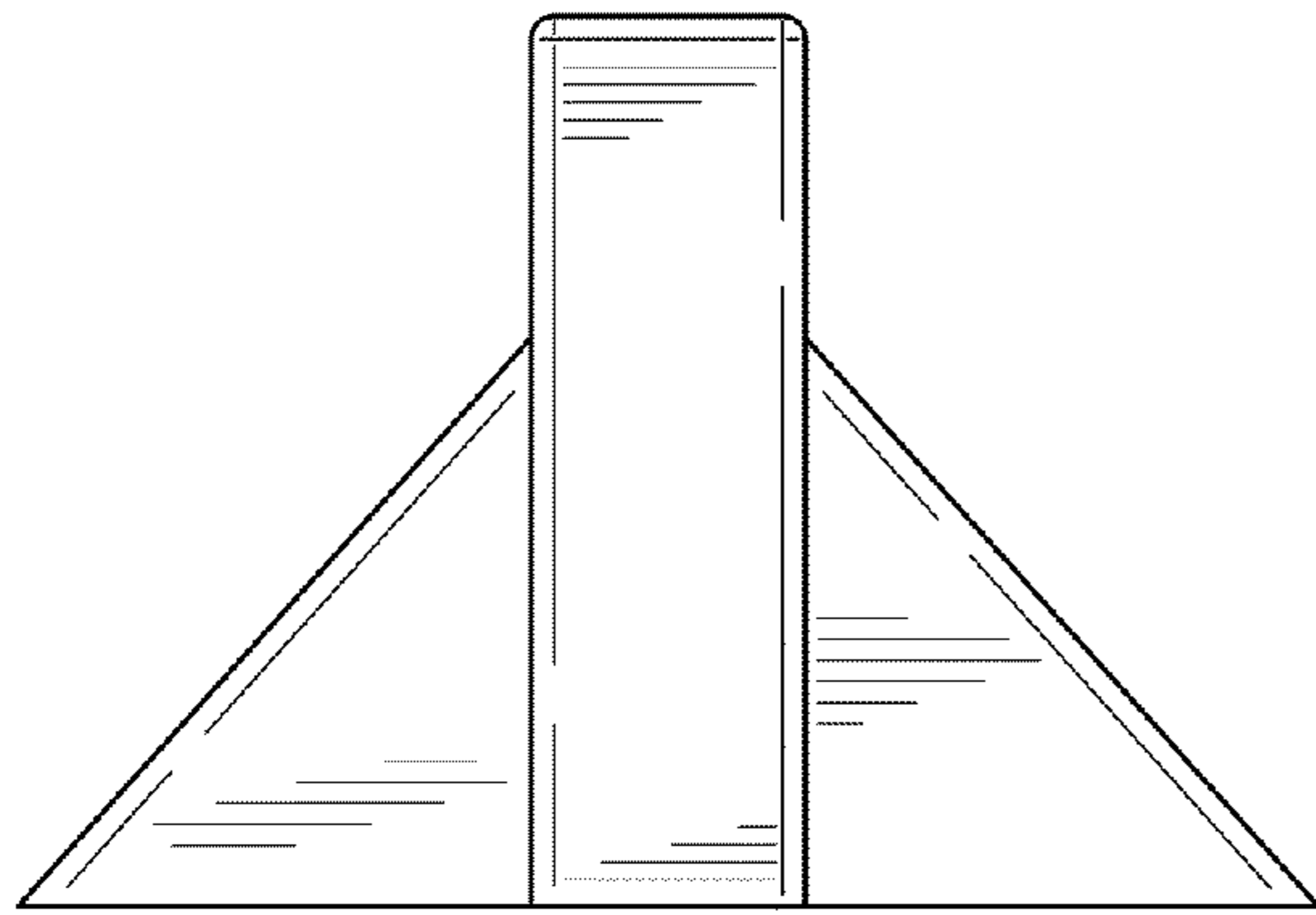

FIG. 4

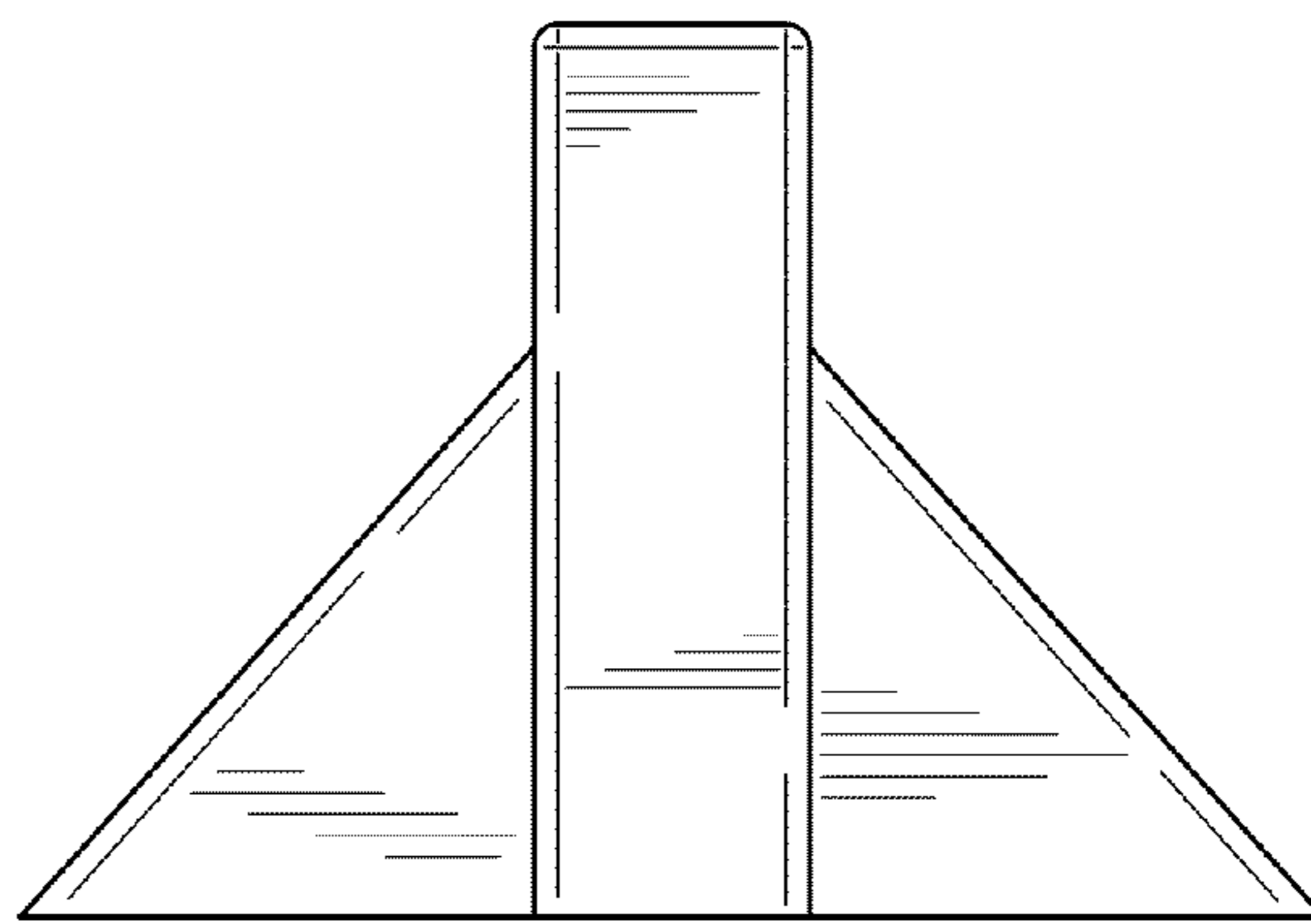

FIG. 5

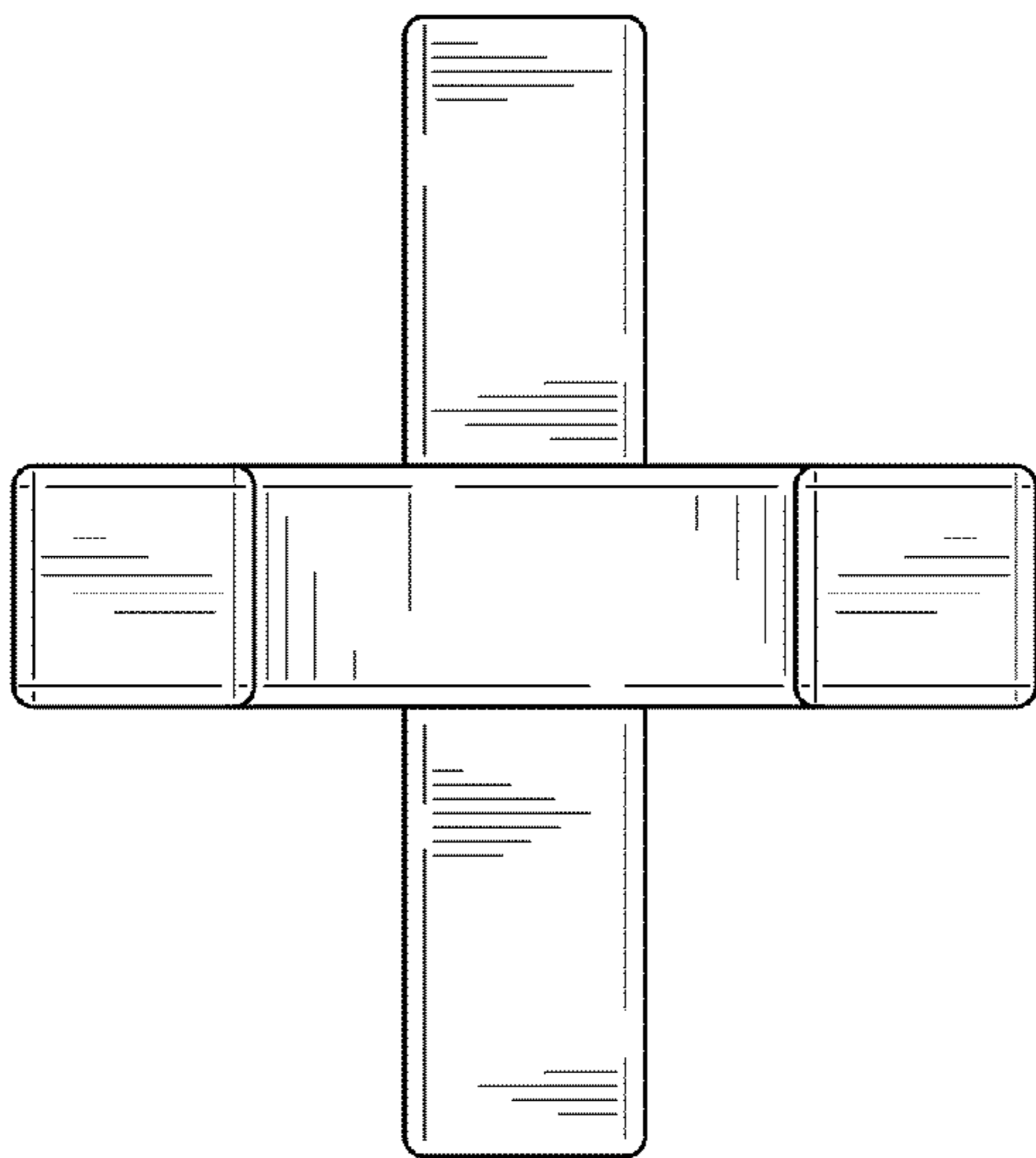

FIG. 6

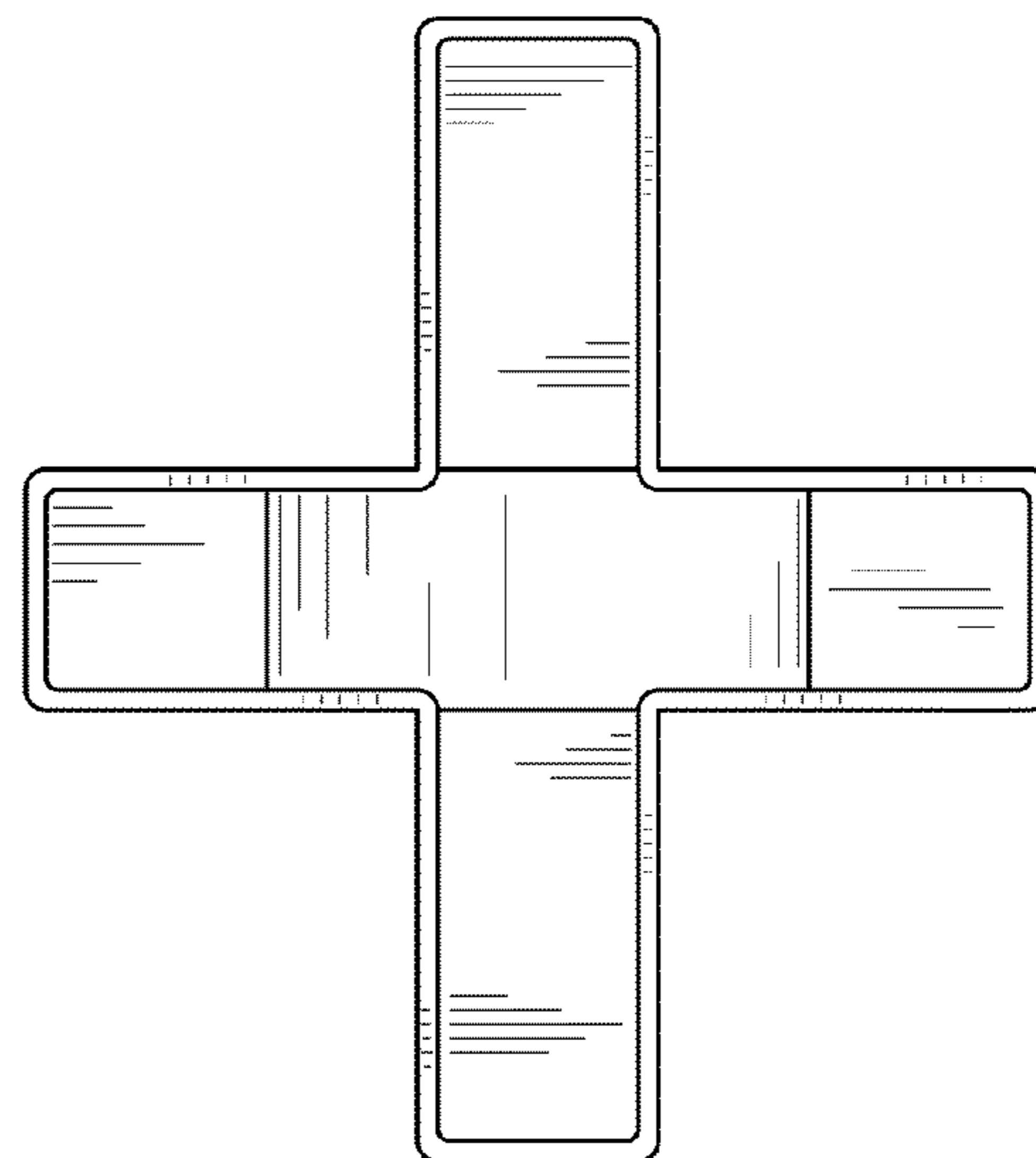

FIG. 7