



US00D737860S

(12) **United States Design Patent**
Mar

(10) **Patent No.:** **US D737,860 S**

(45) **Date of Patent:** **** Sep. 1, 2015**

(54) **VIDEO GAMING SYSTEM**

(71) Applicant: **Steven Mar**, South El Monte, CA (US)

(72) Inventor: **Steven Mar**, South El Monte, CA (US)

(73) Assignee: **Hyperkin Inc.**, South El Monte, CA (US)

(**) Term: **14 Years**

(21) Appl. No.: **29/498,121**

(22) Filed: **Jul. 31, 2014**

(51) **LOC (10) Cl.** **14-03**

(52) **U.S. Cl.**
USPC **D14/496; D21/332; D21/328**

(58) **Field of Classification Search**
USPC D14/496, 401, 435, 474, 483, 217, 137,
D14/138, 160, 168, 356, 203.1-203.8, 507;
345/156, 169, 173-179, 905;
715/727-729, 864; 710/1, 5, 8; 713/1,
713/600; 455/1.1, 1.7, 73, 344-347, 93, 95,
455/3.01-3.06, 550.1, 573.1; 370/342-344;
369/1, 2, 6-12; 463/43-47; 273/148 B;
D21/424-433
CPC H04N 5/00; H04B 10/00; H04J 14/00;
G10H 7/00; G11B 7/00

See application file for complete search history.

(56) **References Cited**

U.S. PATENT DOCUMENTS

4,195,844	A *	4/1980	Okamura et al.	369/77.11
6,328,570	B1 *	12/2001	Ng	434/307 A
6,794,992	B1 *	9/2004	Rogers	341/176
7,003,588	B1 *	2/2006	Takeda et al.	710/8
D572,270	S *	7/2008	Kim	D14/496
D583,798	S *	12/2008	Iijima et al.	D14/168
D594,030	S *	6/2009	Rayn	D14/496
D705,360	S *	5/2014	Mar	D21/332
D726,223	S *	4/2015	Guerrero	D14/496
D730,942	S *	6/2015	Wong	D14/496
2014/0302920	A1	10/2014	Beckett		

* cited by examiner

Primary Examiner — Prabhakar Deshmukh

(74) *Attorney, Agent, or Firm* — Edward C. Schewe

(57) **CLAIM**

The ornamental design for a video gaming system, as shown and described.

DESCRIPTION

FIG. 1 is a front perspective view of a video gaming system showing my new design.
FIG. 2 is a bottom perspective view thereof.
FIG. 3 is a top view thereof.
FIG. 4 is a rear elevation view thereof.
FIG. 5 is a bottom view thereof.
FIG. 6 is a front elevation view thereof.
FIG. 7 is a right side elevation view thereof; and,
FIG. 8 is a left side elevation view thereof.

1 Claim, 8 Drawing Sheets

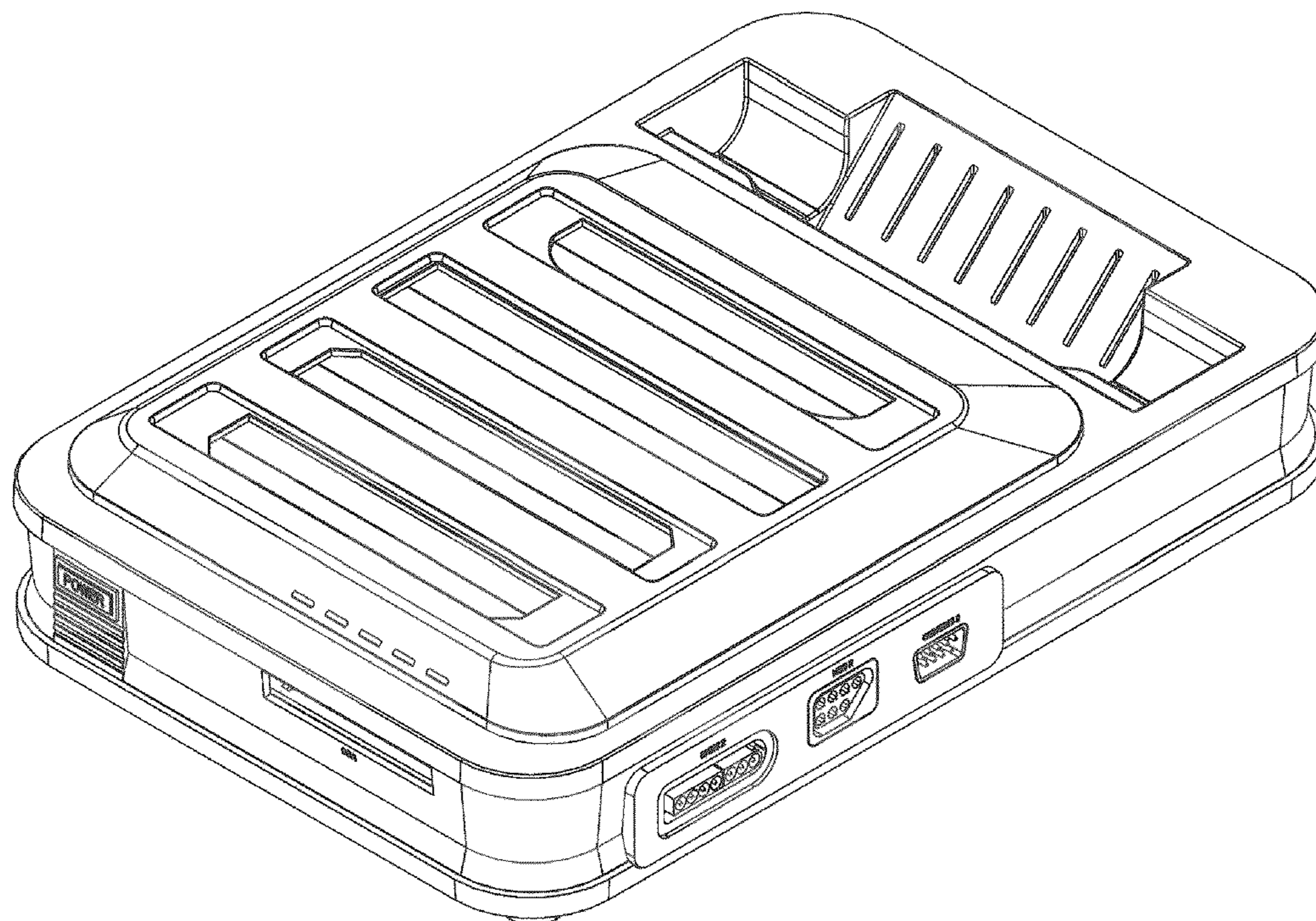

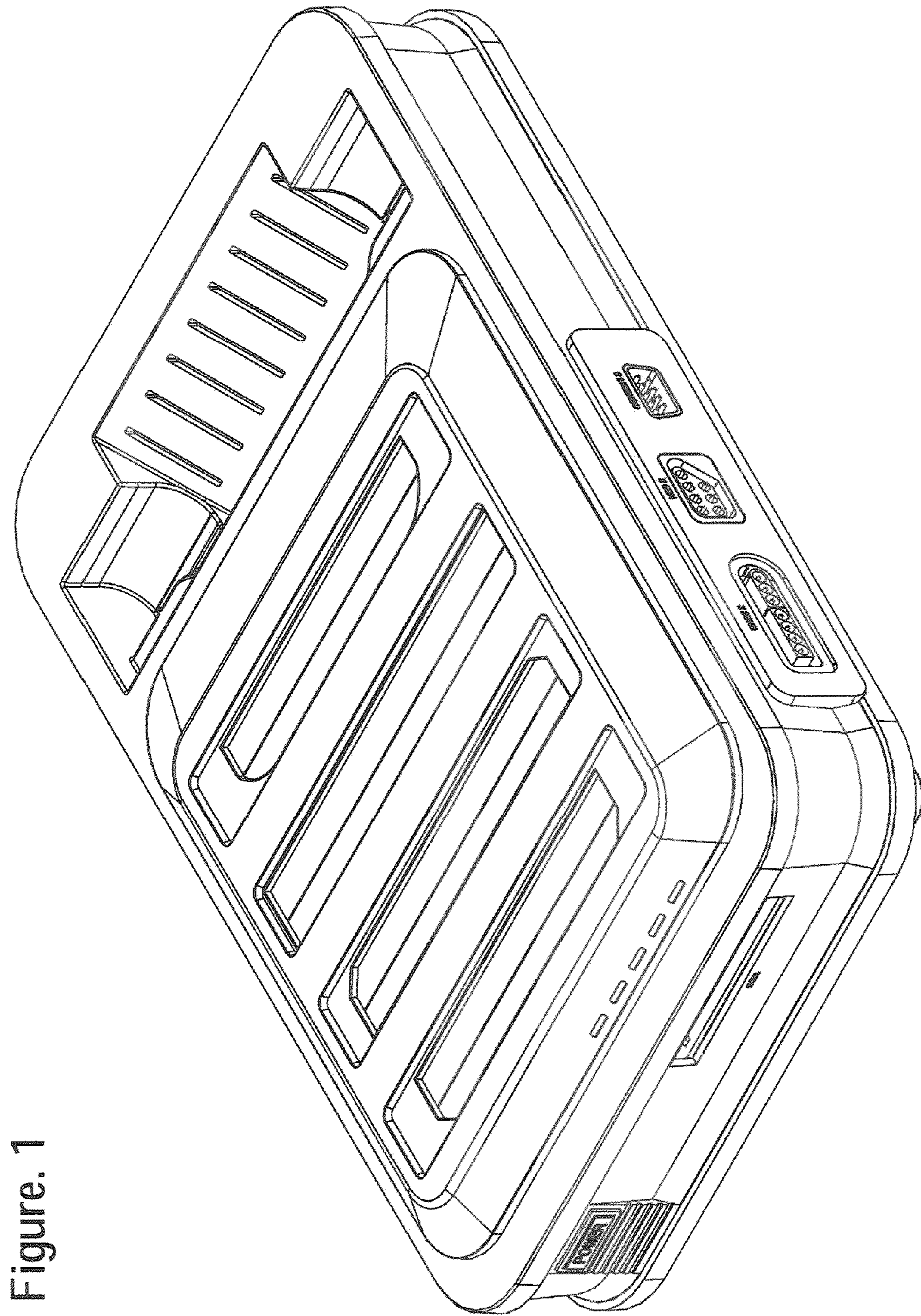

Figure. 1

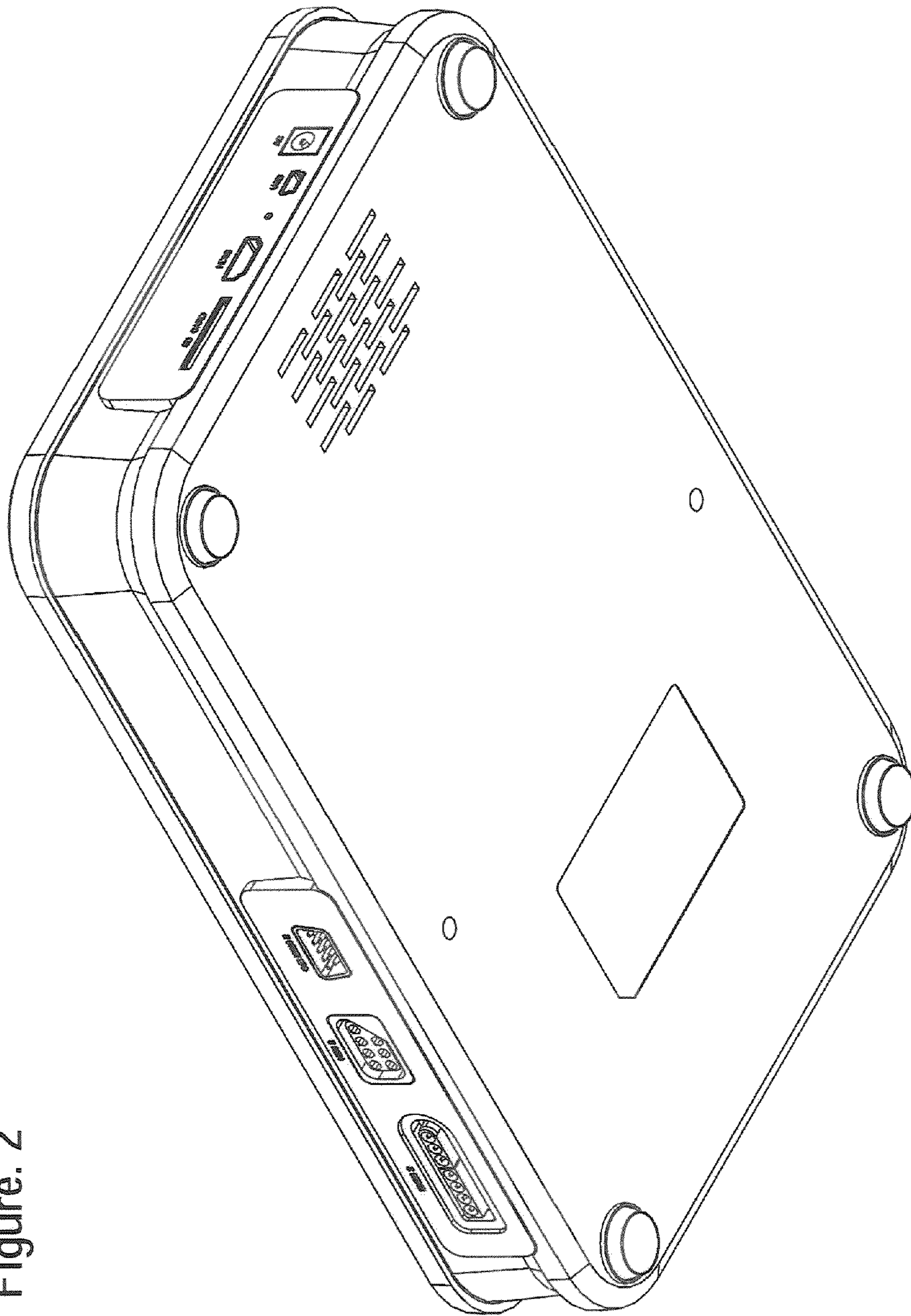

Figure. 2

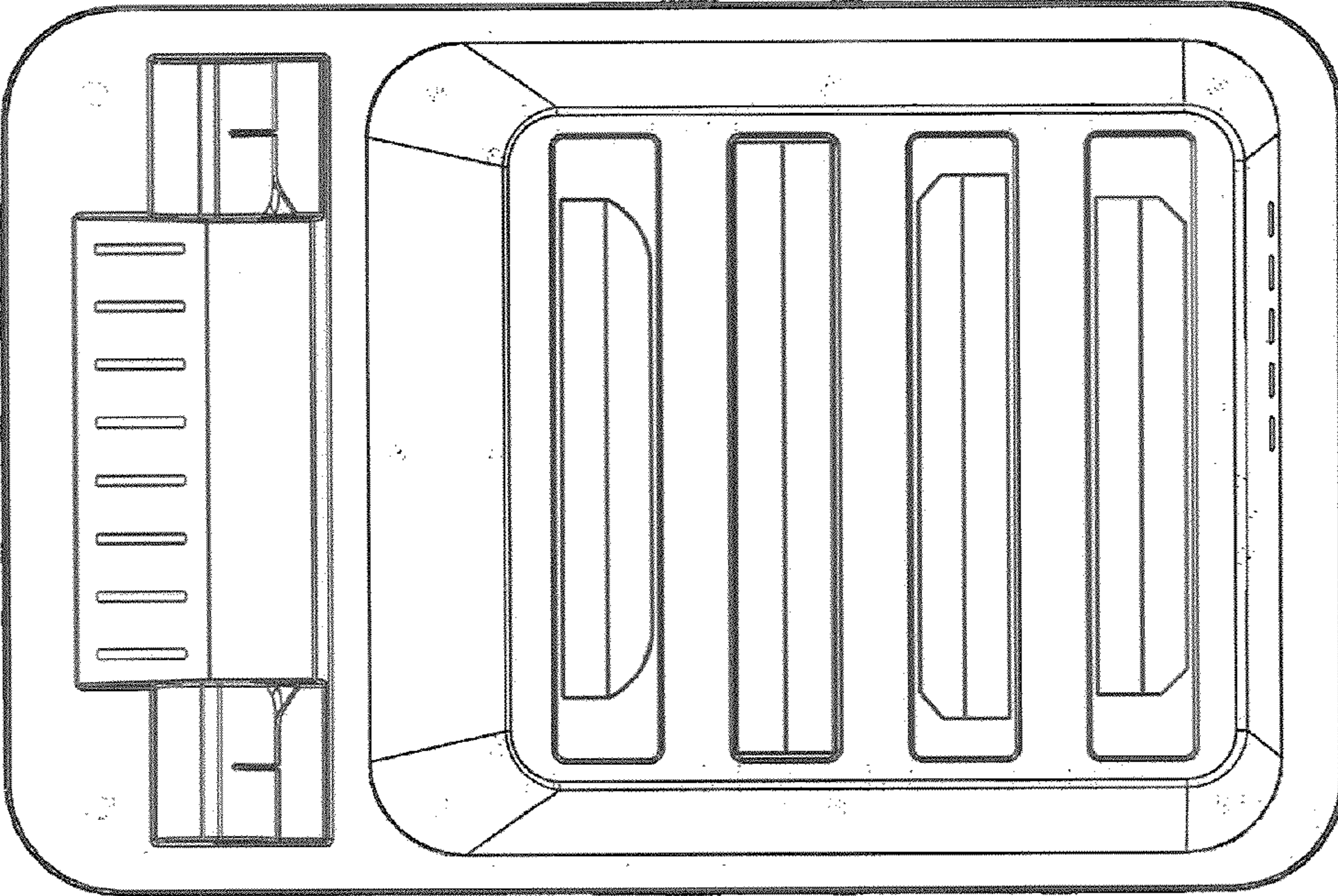

Figure. 3

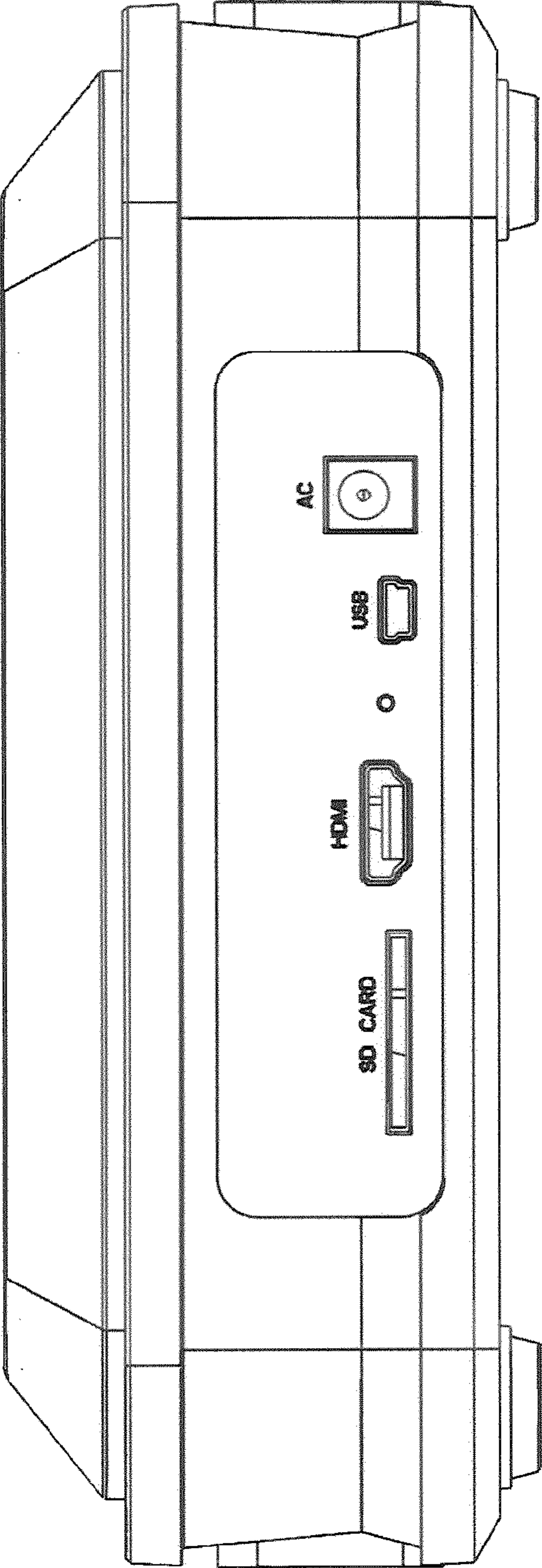

Figure. 4

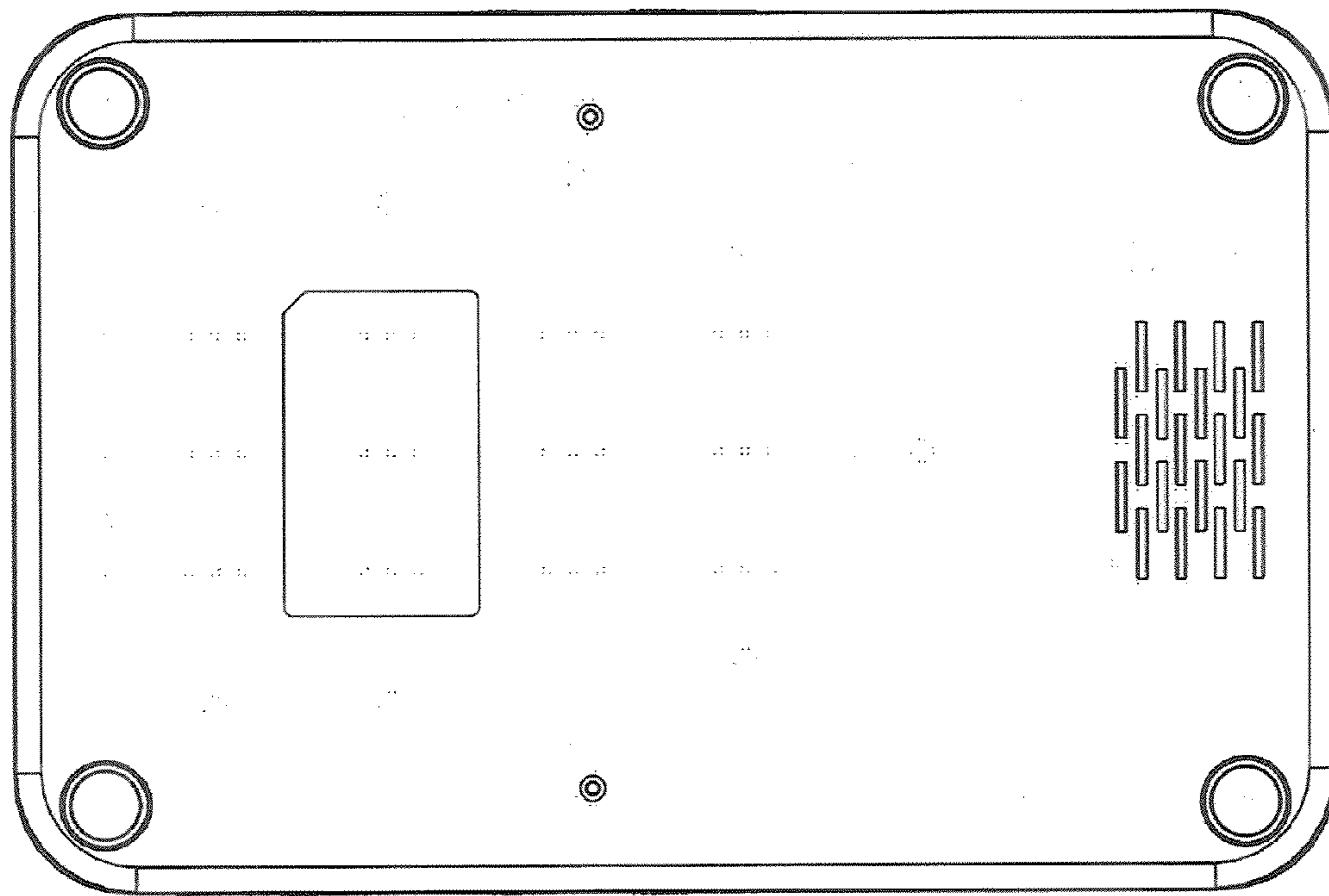

Figure. 5

Figure. 6

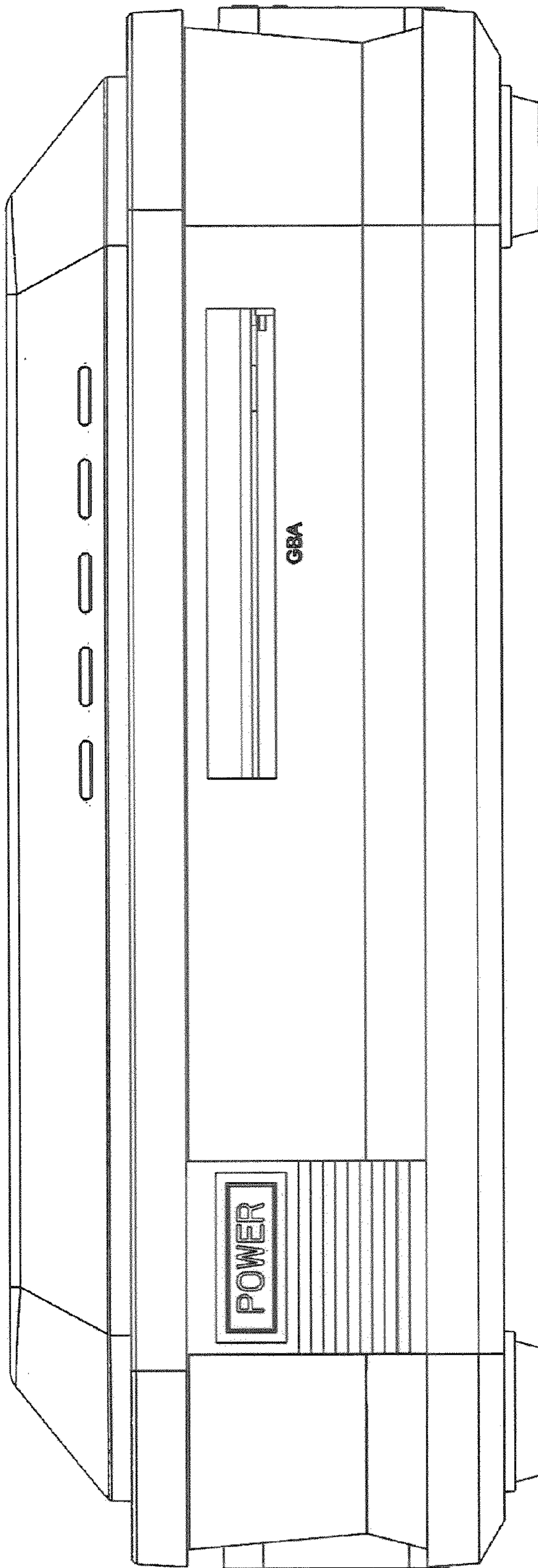

Figure. 7

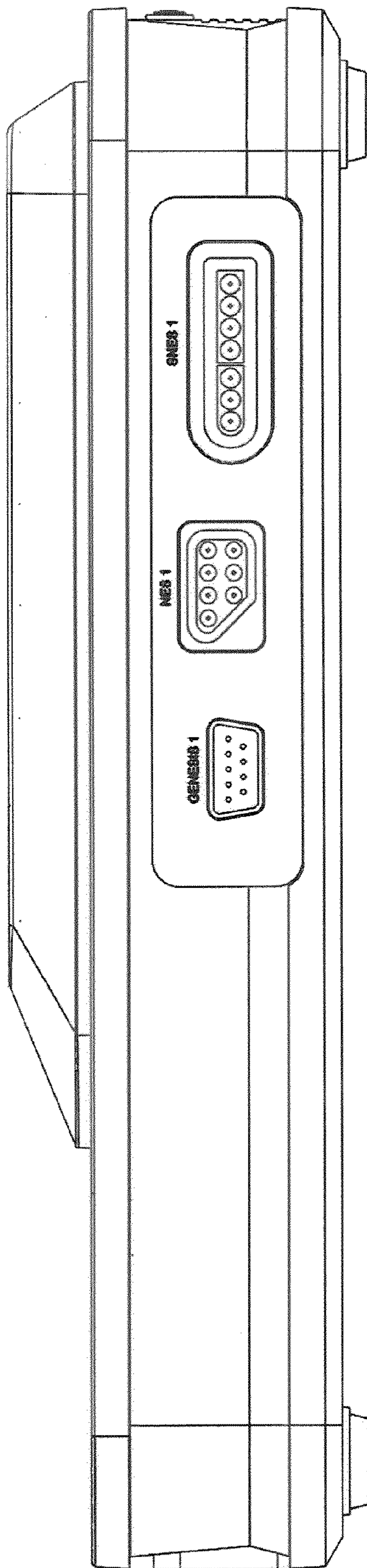

Figure. 8

