

US00D737194S

(12) **United States Design Patent**
Barassi et al.

(10) **Patent No.:** **US D737,194 S**

(45) **Date of Patent:** **** Aug. 25, 2015**

(54) **CAR MODULE**

(71) Applicant: **Automotive Data Solutions Inc.,**
Montreal (CA)

(72) Inventors: **Franco Barassi, Montreal (CA);**
Sébastien Boulais, McMasterville (CA)

(73) Assignee: **Automotive Data Solutions Inc.,**
Montreal, Quebec (CA)

(**) Term: **14 Years**

(21) Appl. No.: **29/455,506**

(22) Filed: **May 21, 2013**

(30) **Foreign Application Priority Data**

Nov. 21, 2012 (CA) 148614

(51) **LOC (10) Cl.** **12-16**

(52) **U.S. Cl.**
USPC **D12/400**

(58) **Field of Classification Search**
USPC D12/400, 190, 196, 93, 91, 173, 183,
D12/88, 92; 439/34-35; D14/258
See application file for complete search history.

(56) **References Cited**

U.S. PATENT DOCUMENTS

4,936,787	A *	6/1990	Klein et al.	439/76.1
5,441,421	A *	8/1995	Ponticelli et al.	439/284
D385,284	S *	10/1997	Brenner	D14/258
5,971,799	A *	10/1999	Swade	439/502
6,030,242	A *	2/2000	Cunningham et al.	439/247
D613,733	S *	4/2010	Iwamoto	D14/258
D679,677	S *	4/2013	Tomono et al.	D14/168
D680,095	S *	4/2013	Tomono	D14/168

* cited by examiner

Primary Examiner — Katrina A Betton

(74) *Attorney, Agent, or Firm* — Robert Brouillette;
Brouillette & Partners

(57) **CLAIM**

The ornamental design for a car module, as shown and described.

DESCRIPTION

FIG. 1 is a top perspective view of the car module;
FIG. 2 is a left view of the car module;
FIG. 3 is a rear view of the car module;
FIG. 4 is a front view of the car module;
FIG. 5 is a top view of the car module;
FIG. 6 is a bottom view of the car module;
FIG. 7 is a right view of the car module;
FIG. 8 is a top perspective view of a second embodiment of the car module;
FIG. 9 is a left view of the second embodiment of the car module;
FIG. 10 is a rear view of the second embodiment of the car module;
FIG. 11 is a front view of the second embodiment of the car module;
FIG. 12 is a top view of the second embodiment of the car module;
FIG. 13 is a bottom view of the second embodiment of the car module; and,
FIG. 14 is a right view of the second embodiment of the car module.

The elements and/or structures shown in broken lines are shown for illustration purposes only and do not form part of the claimed design.

1 Claim, 6 Drawing Sheets

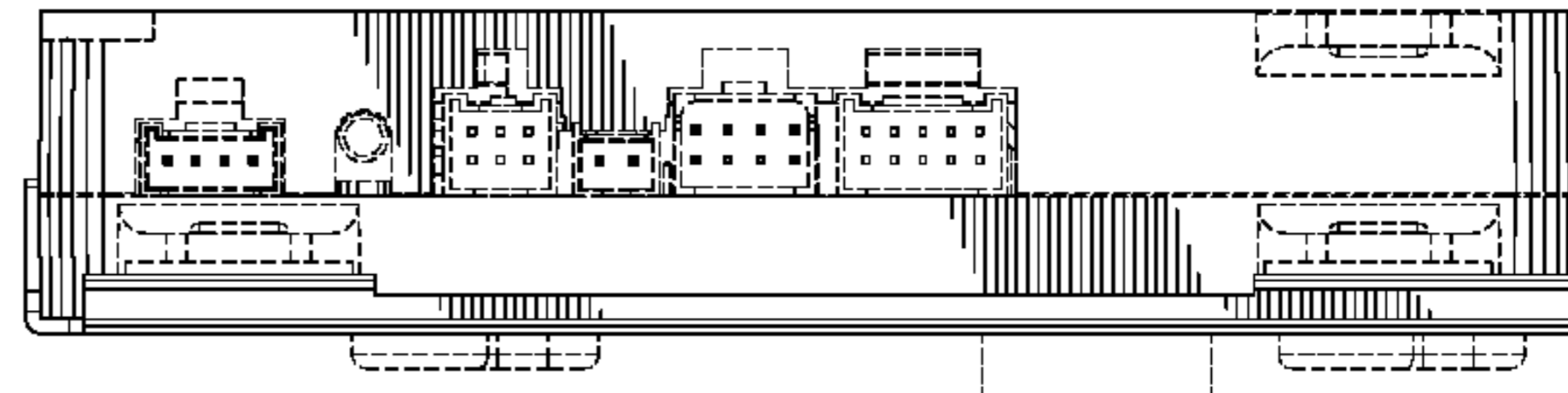
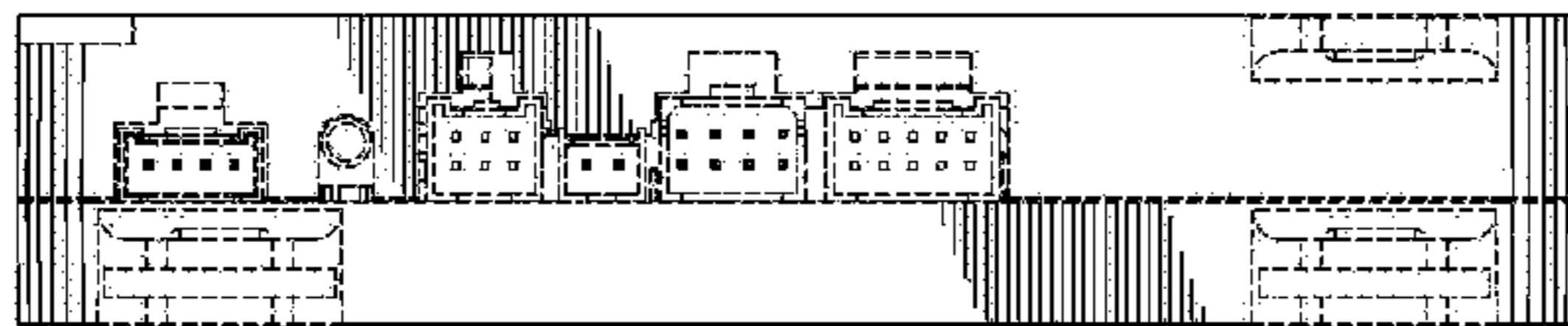

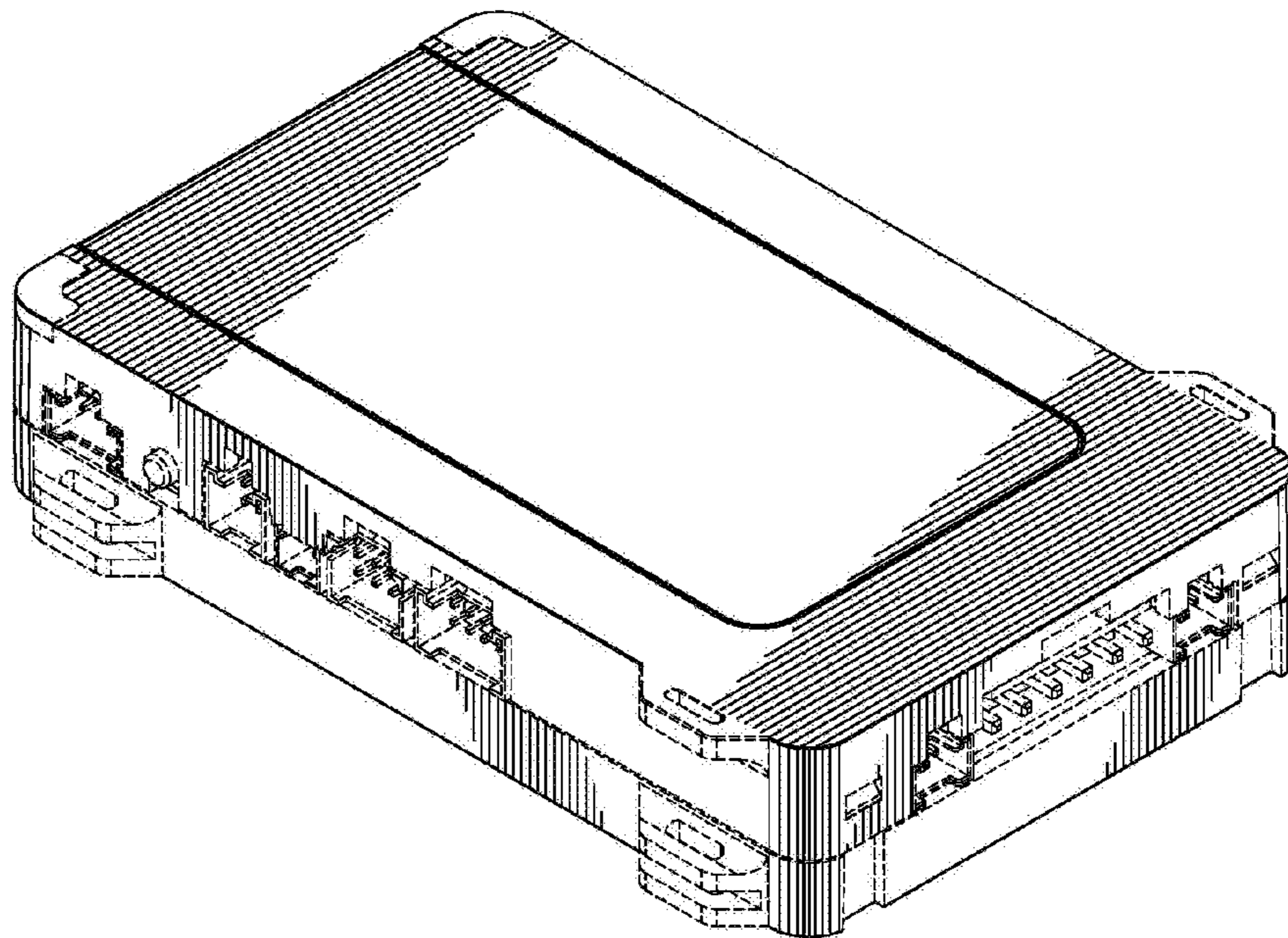

FIG. 1

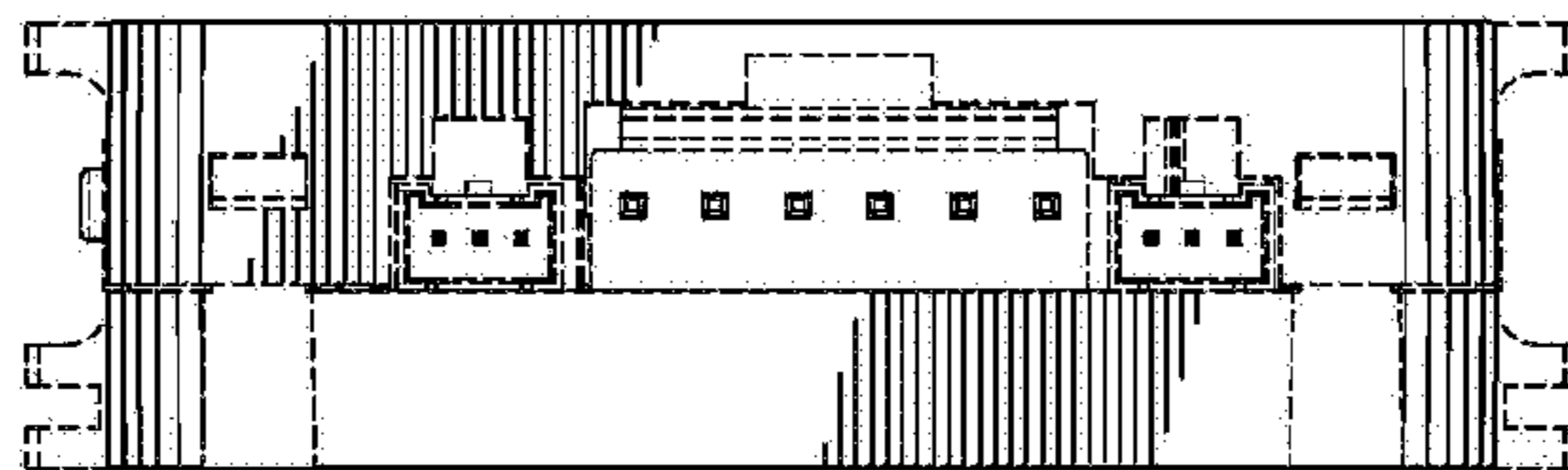

FIG. 2

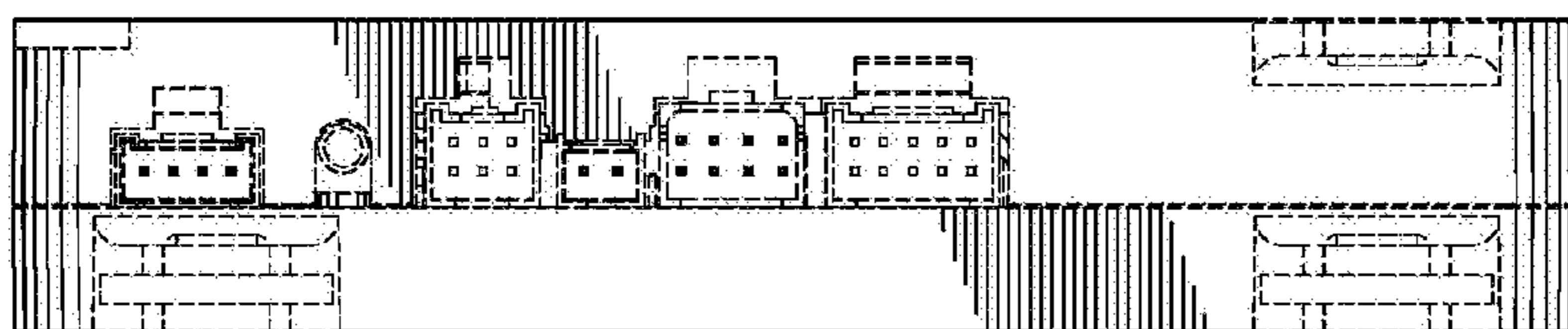

FIG. 3

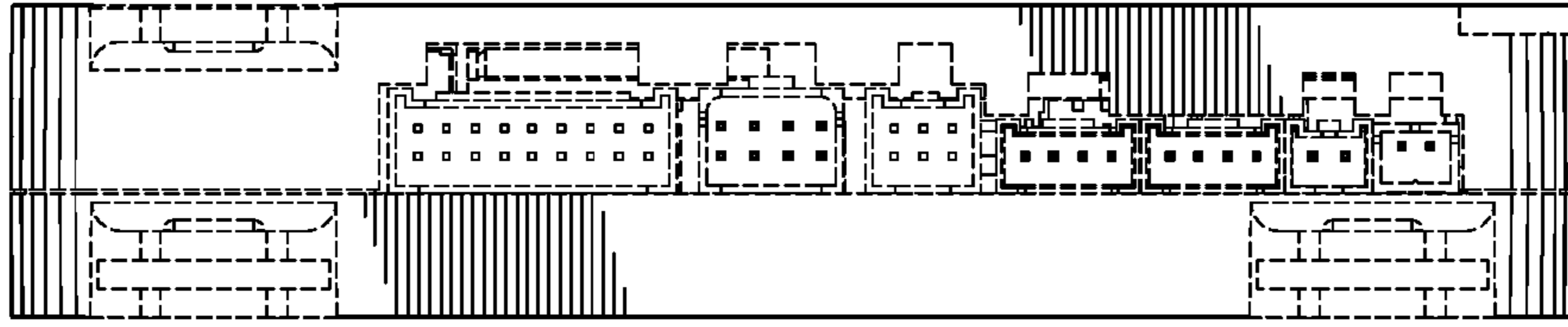

FIG. 4

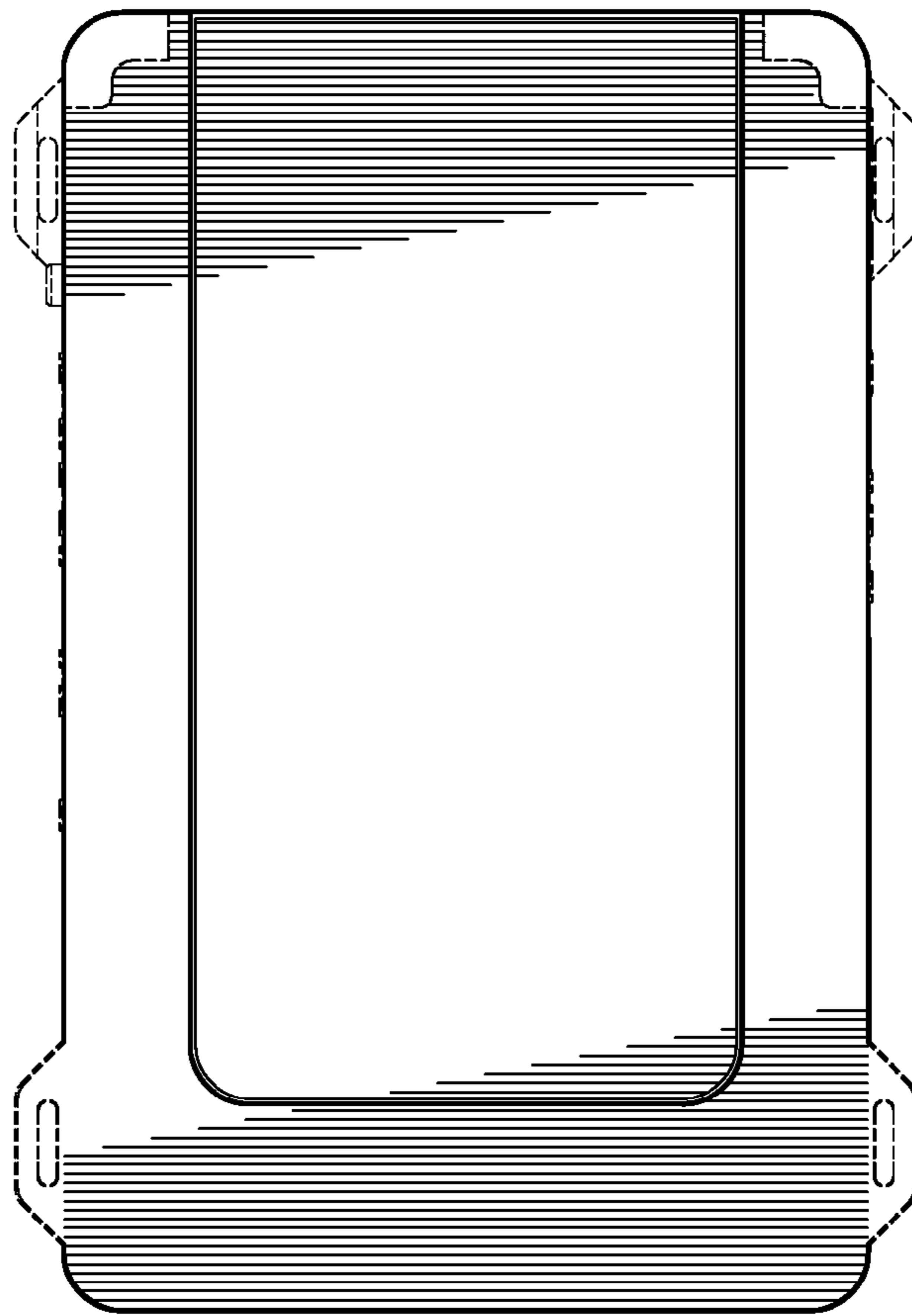

FIG. 5

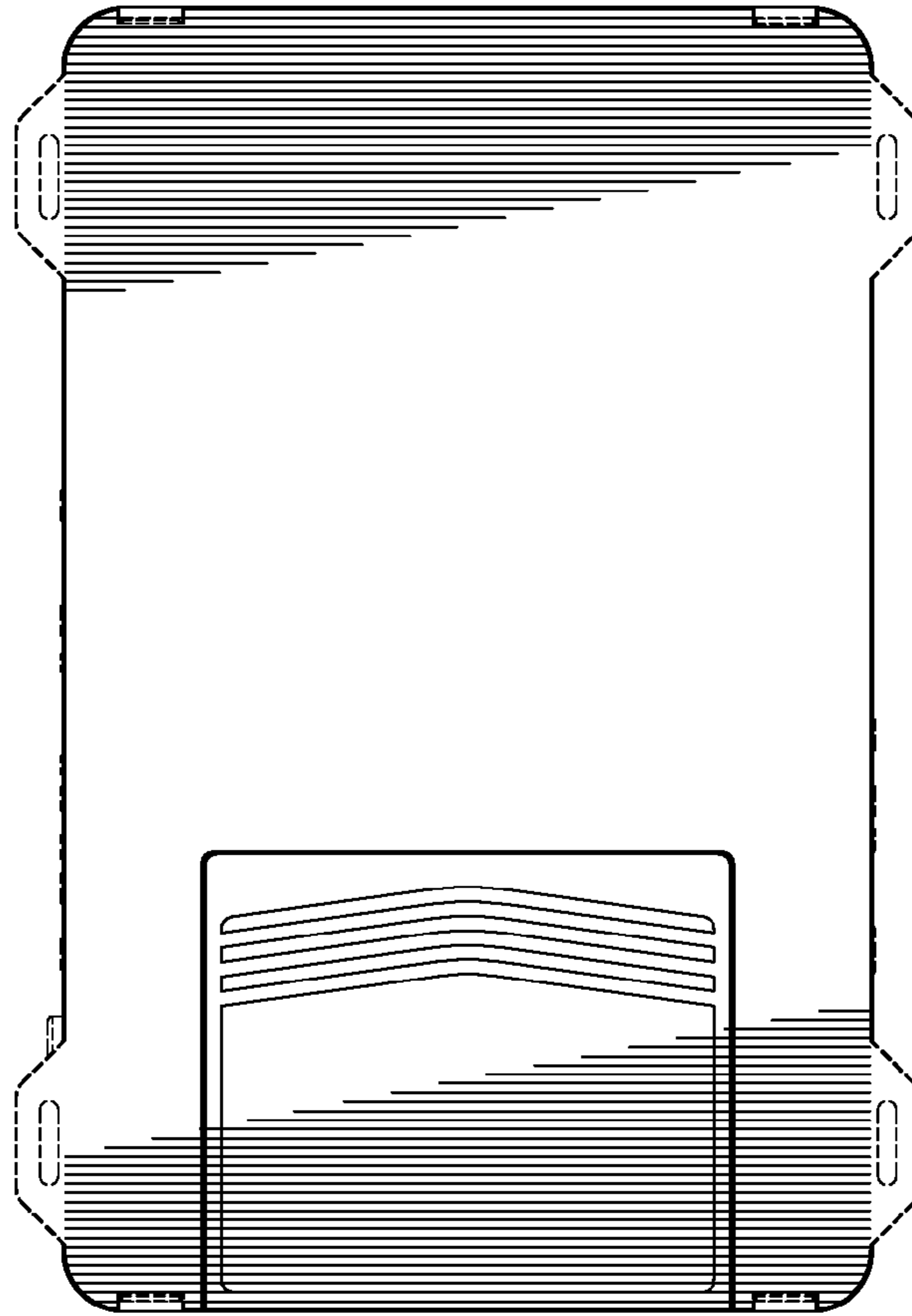

FIG. 6

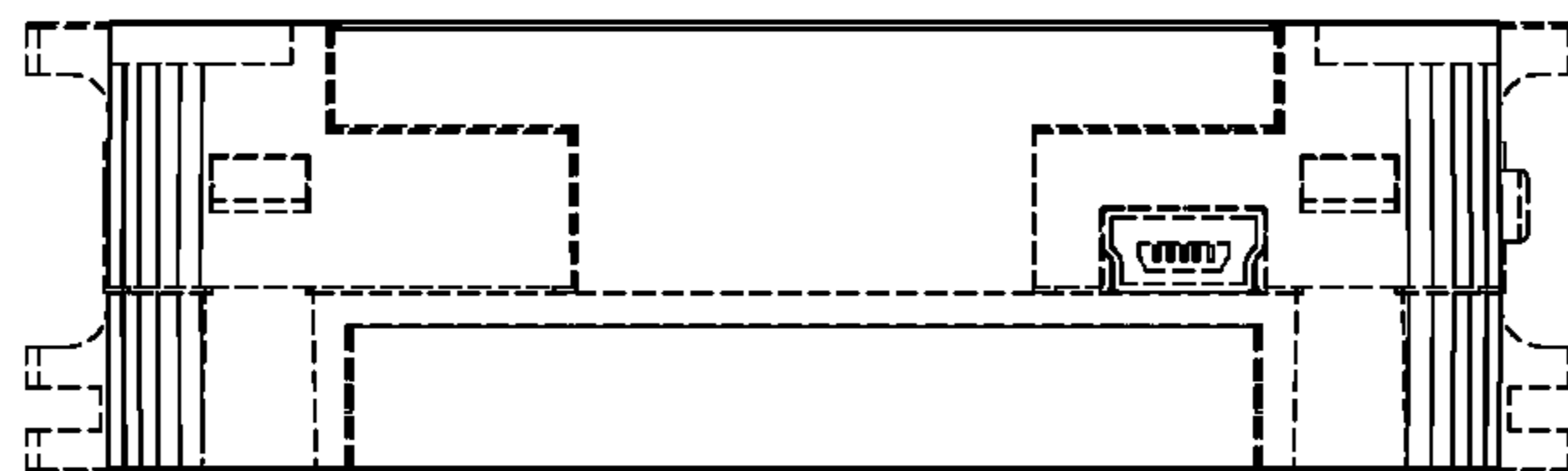

FIG. 7

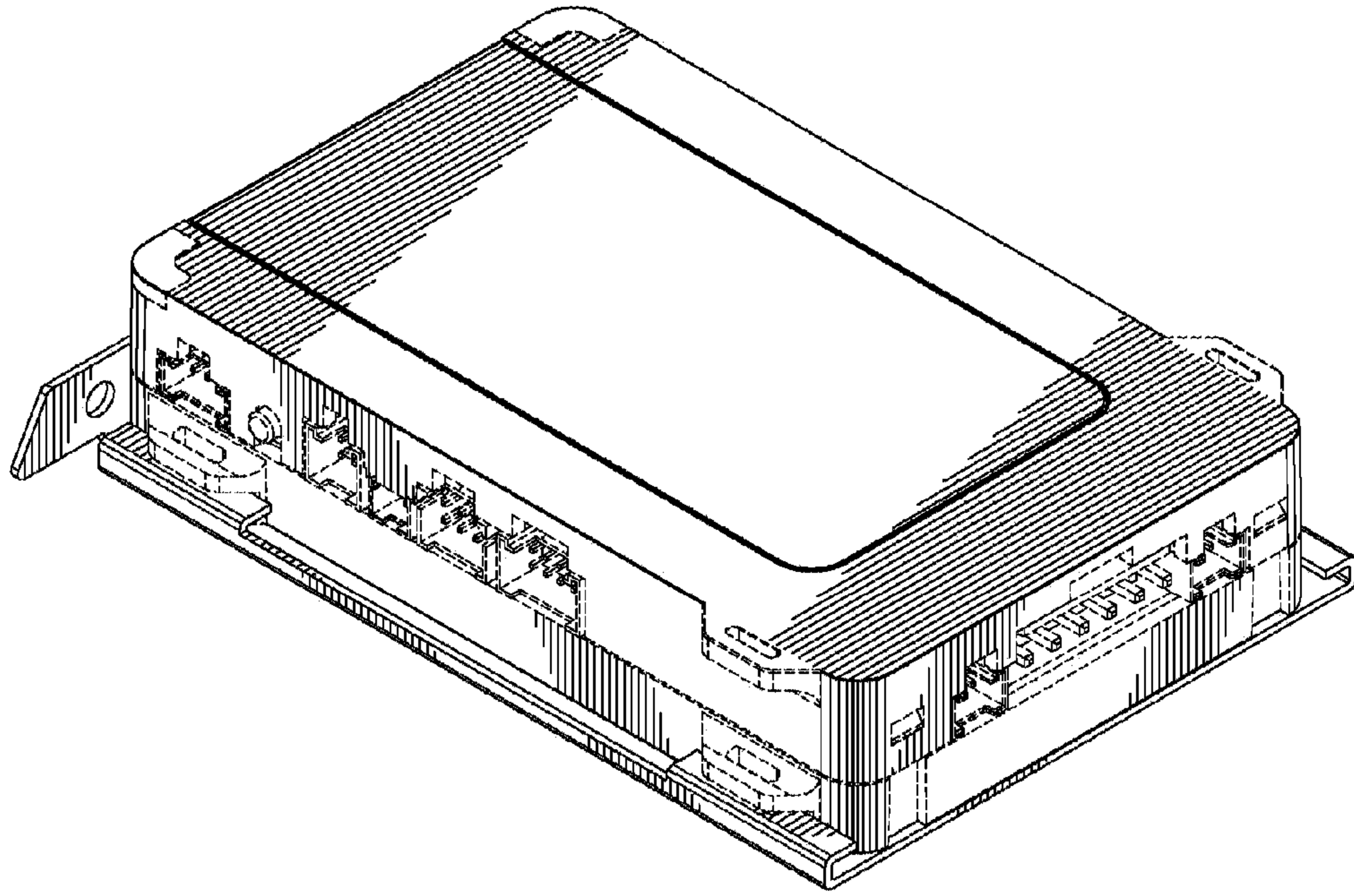

FIG. 8

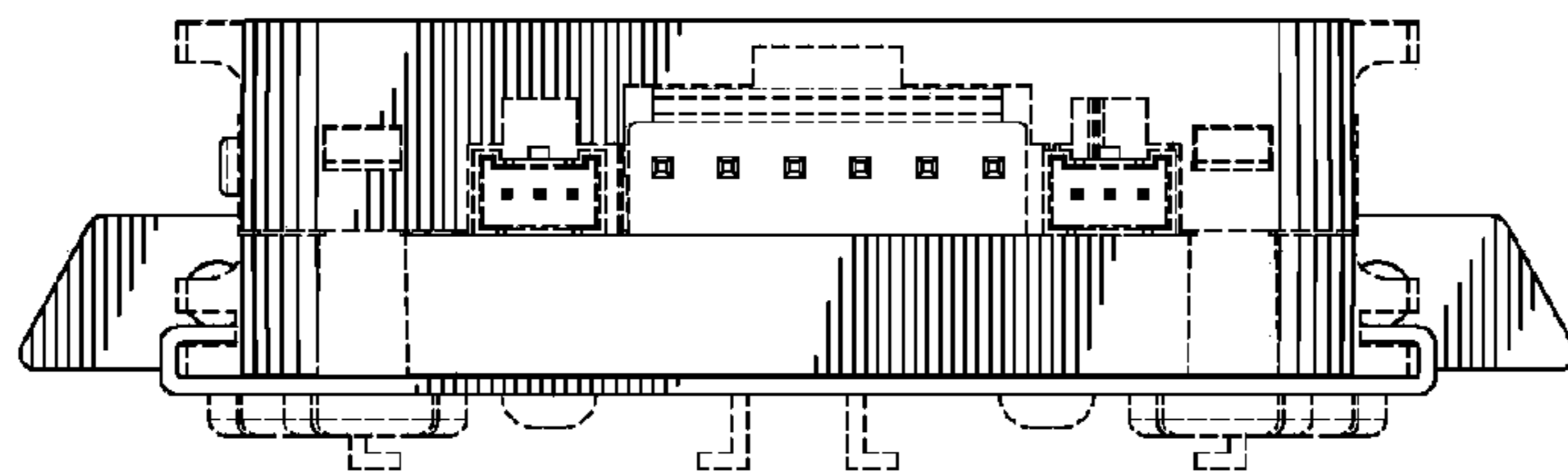

FIG. 9

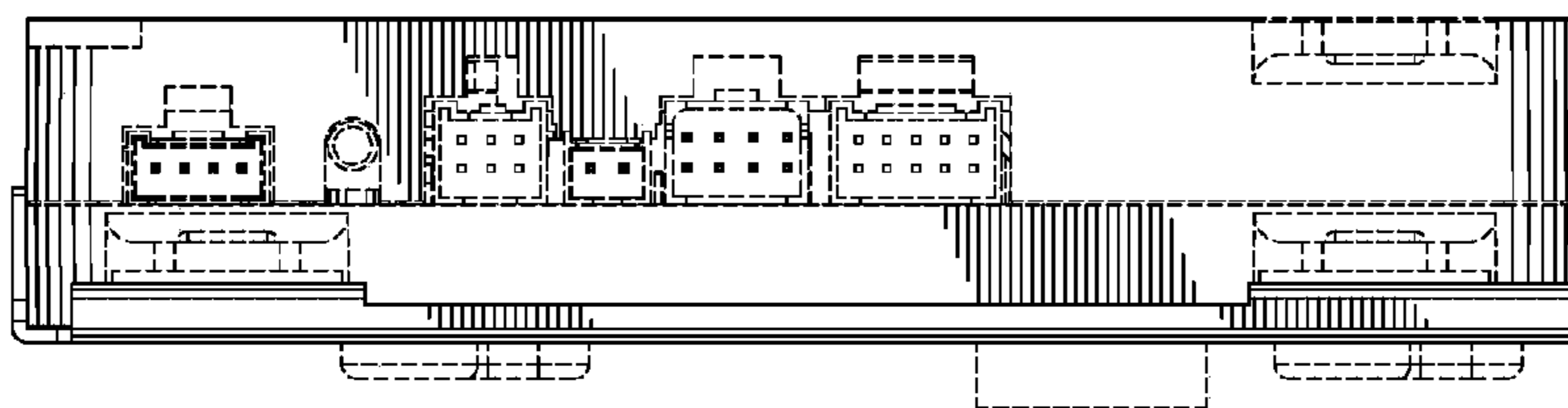

FIG. 10

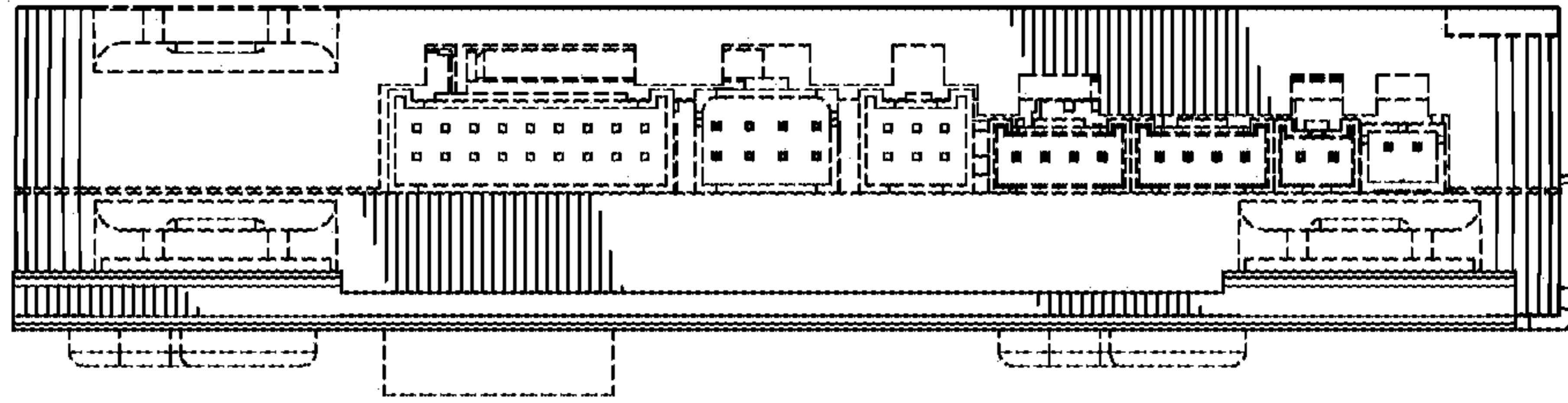

FIG. 11

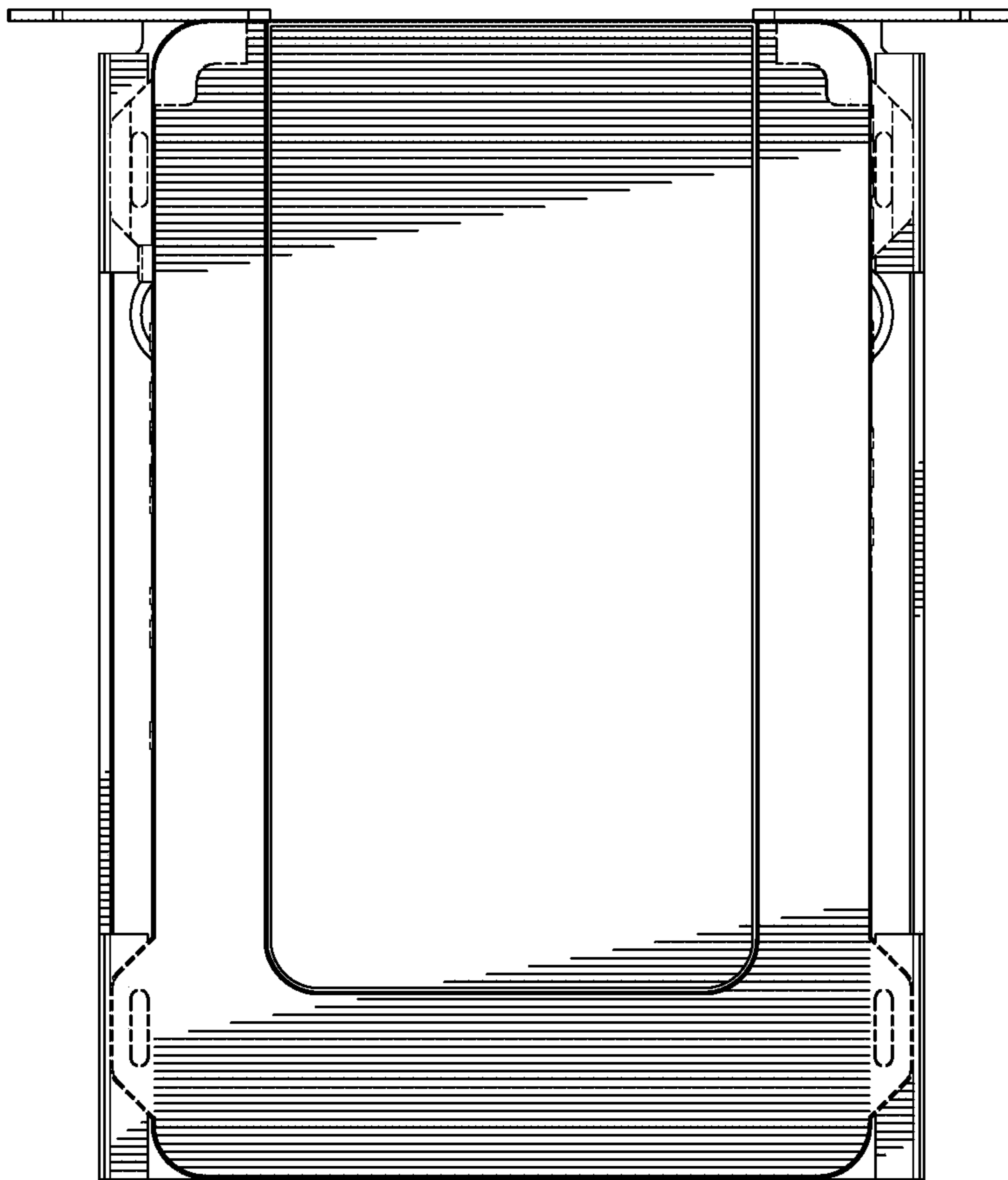

FIG. 12

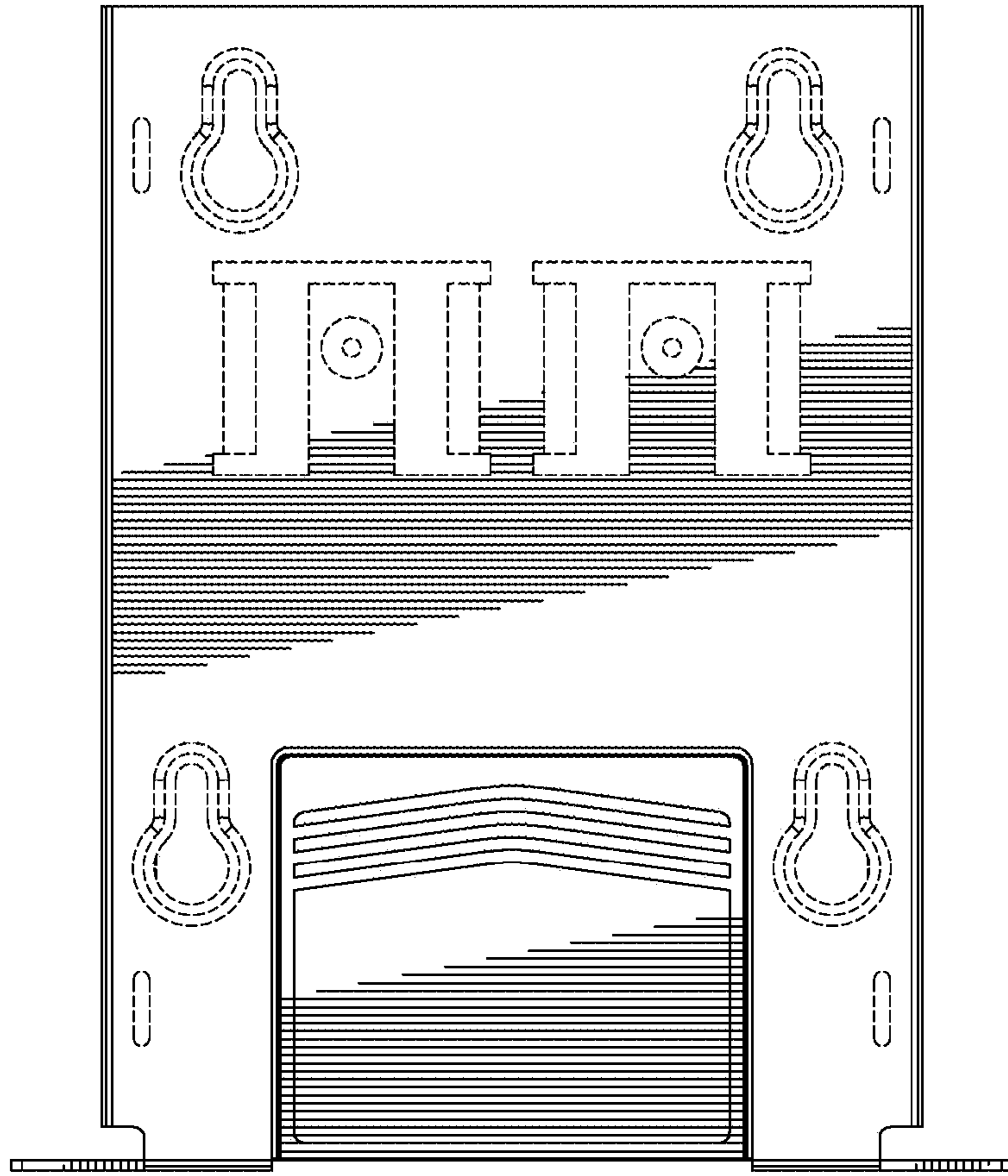

FIG. 13

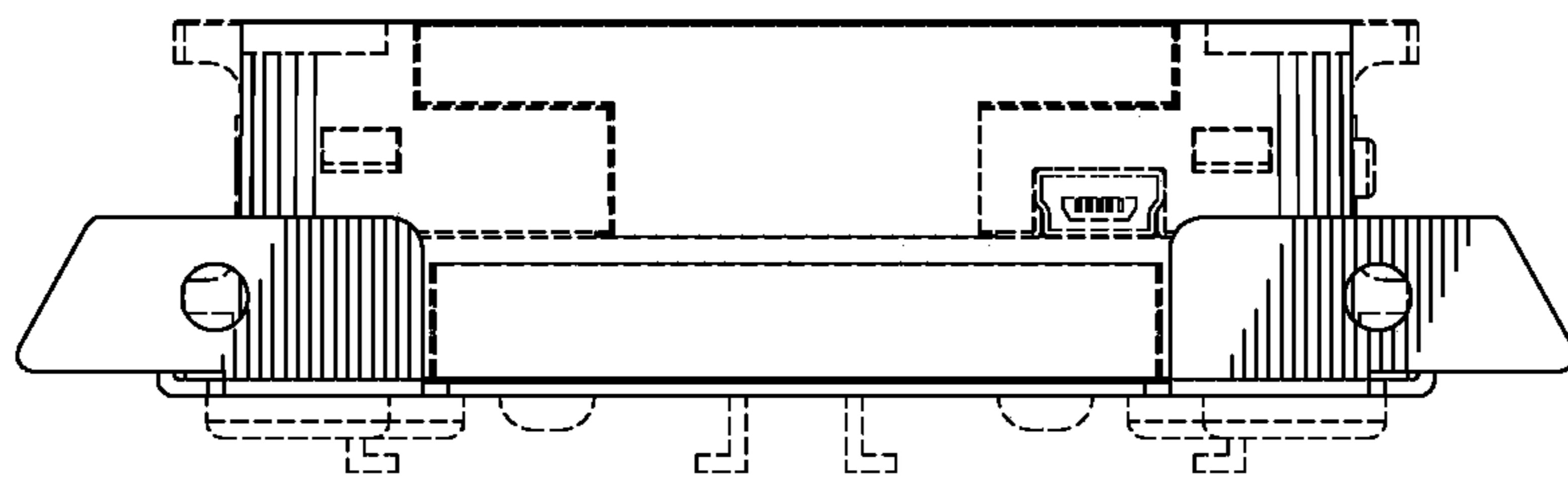

FIG. 14