

US00D737191S

(12) **United States Design Patent**  
**Chung**

(10) **Patent No.:** **US D737,191 S**

(45) **Date of Patent:** **\*\* Aug. 25, 2015**

(54) **AUTOMOTIVE WHEEL**

(71) Applicant: **Suny Chung**, Anaheim, CA (US)

(72) Inventor: **Suny Chung**, Anaheim, CA (US)

(\*\*) Term: **14 Years**

(21) Appl. No.: **29/500,248**

(22) Filed: **Aug. 22, 2014**

(51) **LOC (10) Cl.** ..... **12-16**

(52) **U.S. Cl.**  
USPC ..... **D12/211**

(58) **Field of Classification Search**  
USPC ..... D12/204–213  
CPC ..... B60B 7/00; B60B 7/02; B60B 7/04;  
B60B 7/01; B60B 7/06; B60B 3/02; B60B  
3/04; B60B 3/06; B60B 3/10; B60B 1/00;  
B60B 1/08; B60B 1/10; B60B 1/12  
See application file for complete search history.

(56) **References Cited**

**U.S. PATENT DOCUMENTS**

D235,431 S	*	6/1975	Scott	.....	D12/205
D474,141 S	*	5/2003	Foose	.....	D12/211
D496,320 S	*	9/2004	Cheng	.....	D12/211
D553,070 S	*	10/2007	Tirado	.....	D12/211

D557,650 S	*	12/2007	Musser	.....	D12/211
D569,778 S	*	5/2008	Kim	.....	D12/211
D578,458 S	*	10/2008	Cortes	.....	D12/211
D582,334 S	*	12/2008	Fournier	.....	D12/211
D590,315 S	*	4/2009	Chung	.....	D12/209
D624,863 S	*	10/2010	Zhao	.....	D12/211
D625,245 S	*	10/2010	Hans et al.	.....	D12/211
D630,992 S	*	1/2011	Cortes	.....	D12/211
D704,124 S	*	5/2014	Hale, Jr.	.....	D12/211

\* cited by examiner

*Primary Examiner* — Stacia Cadmus

(57) **CLAIM**

The ornamental design for an automotive wheel, as shown and described

**DESCRIPTION**

FIG. 1 is a perspective view of an automotive wheel, showing my new design; and  
FIG. 2 is a front view thereof  
FIG. 3 is a perspective view of a second embodiment of automotive wheel, showing my new design without center cap; and,  
FIG. 4 is a front view of FIG. 3.  
The broken line showing of the rear portion of the wheel is included for the purpose of illustrating environment and forms no part of the claimed design.

**1 Claim, 4 Drawing Sheets**

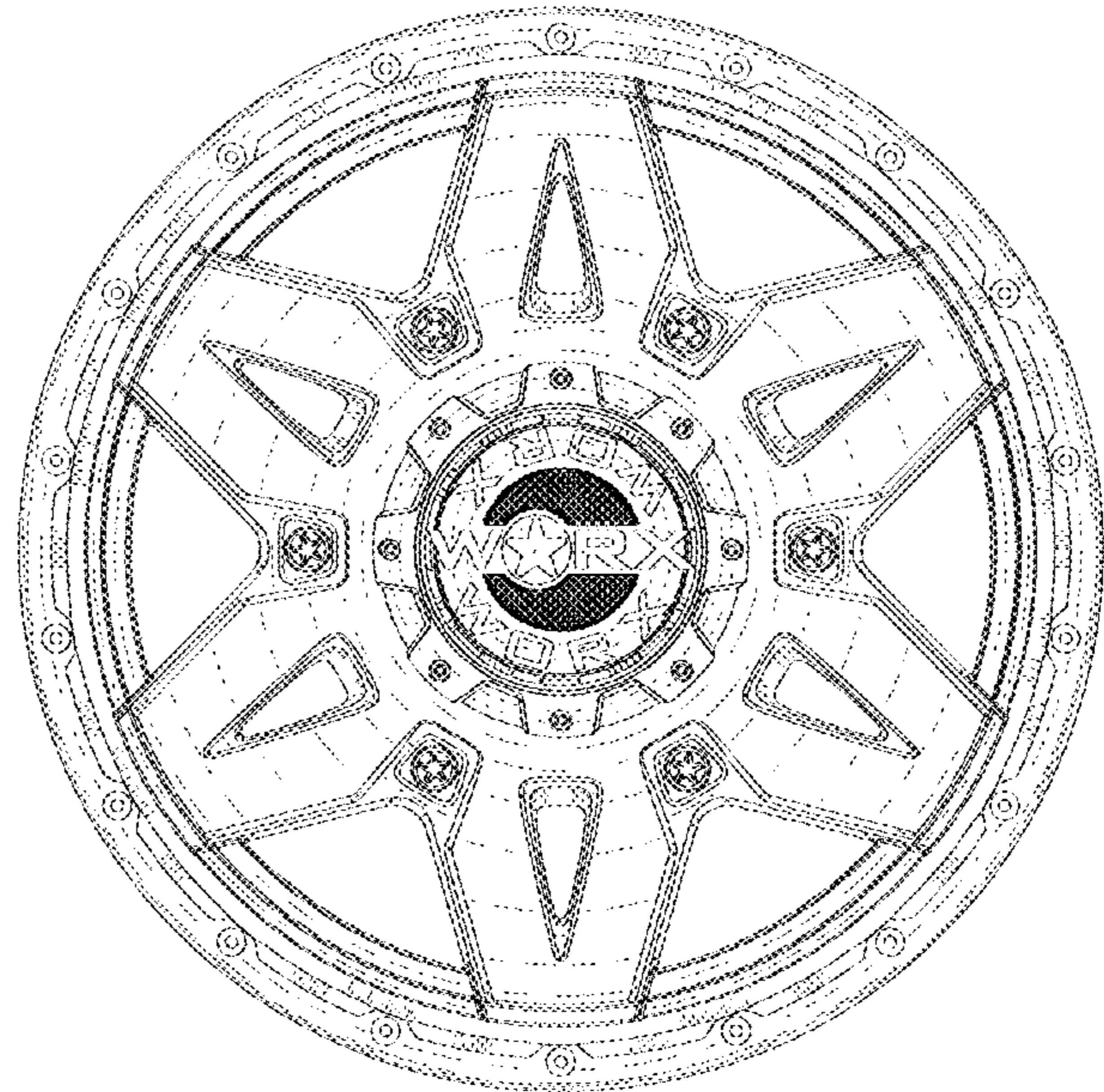
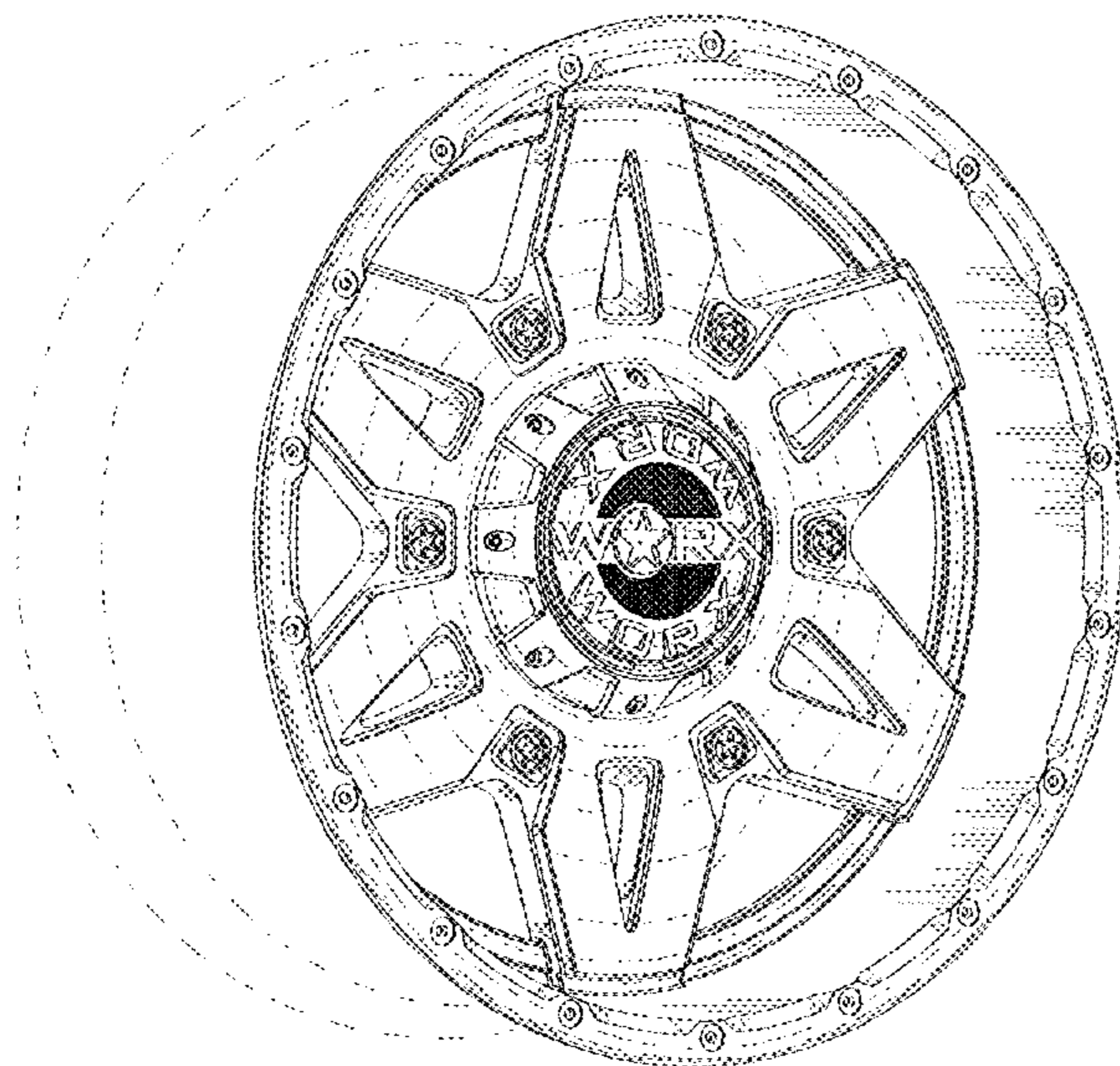

FIGURE 1

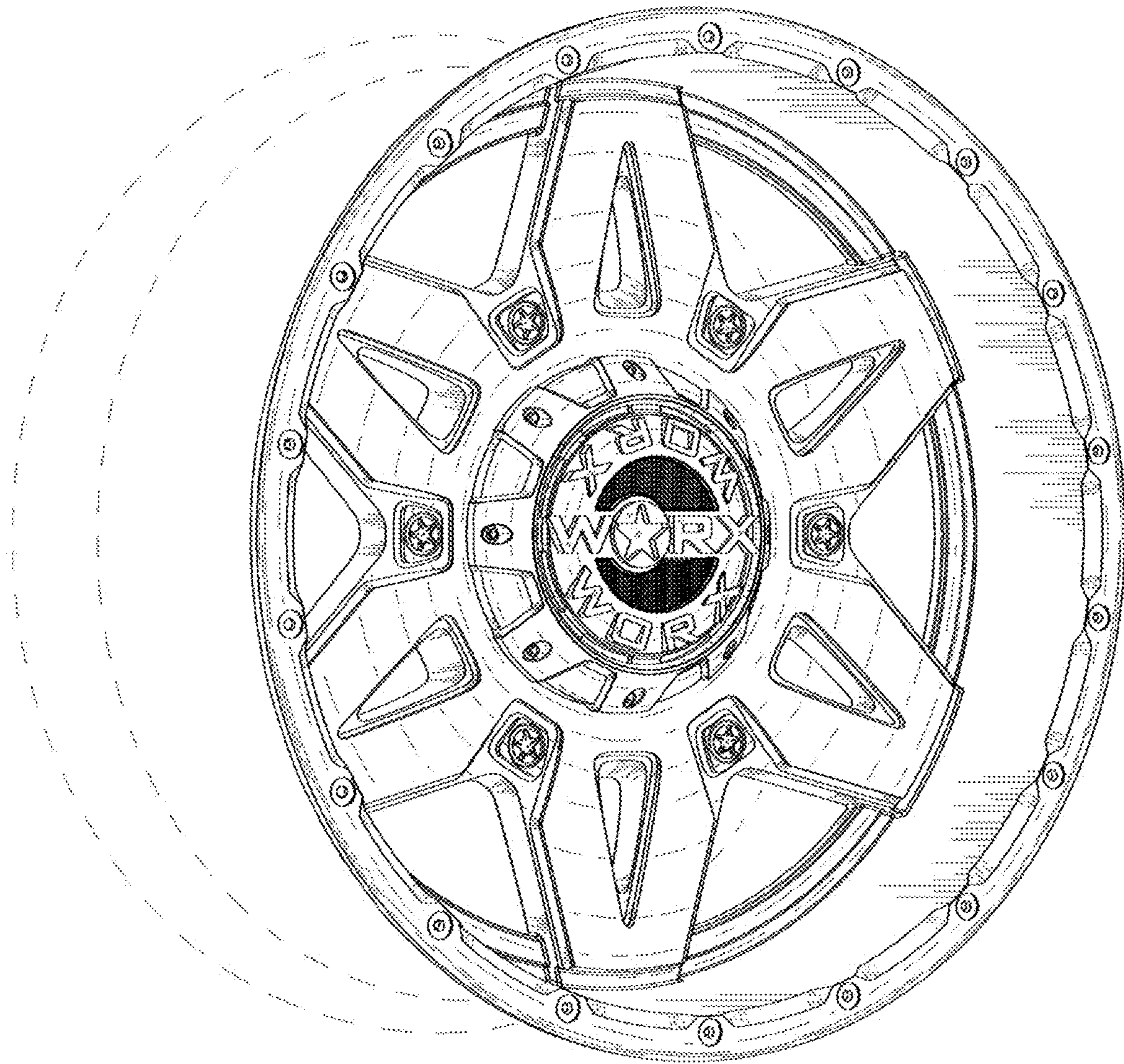

FIGURE 2

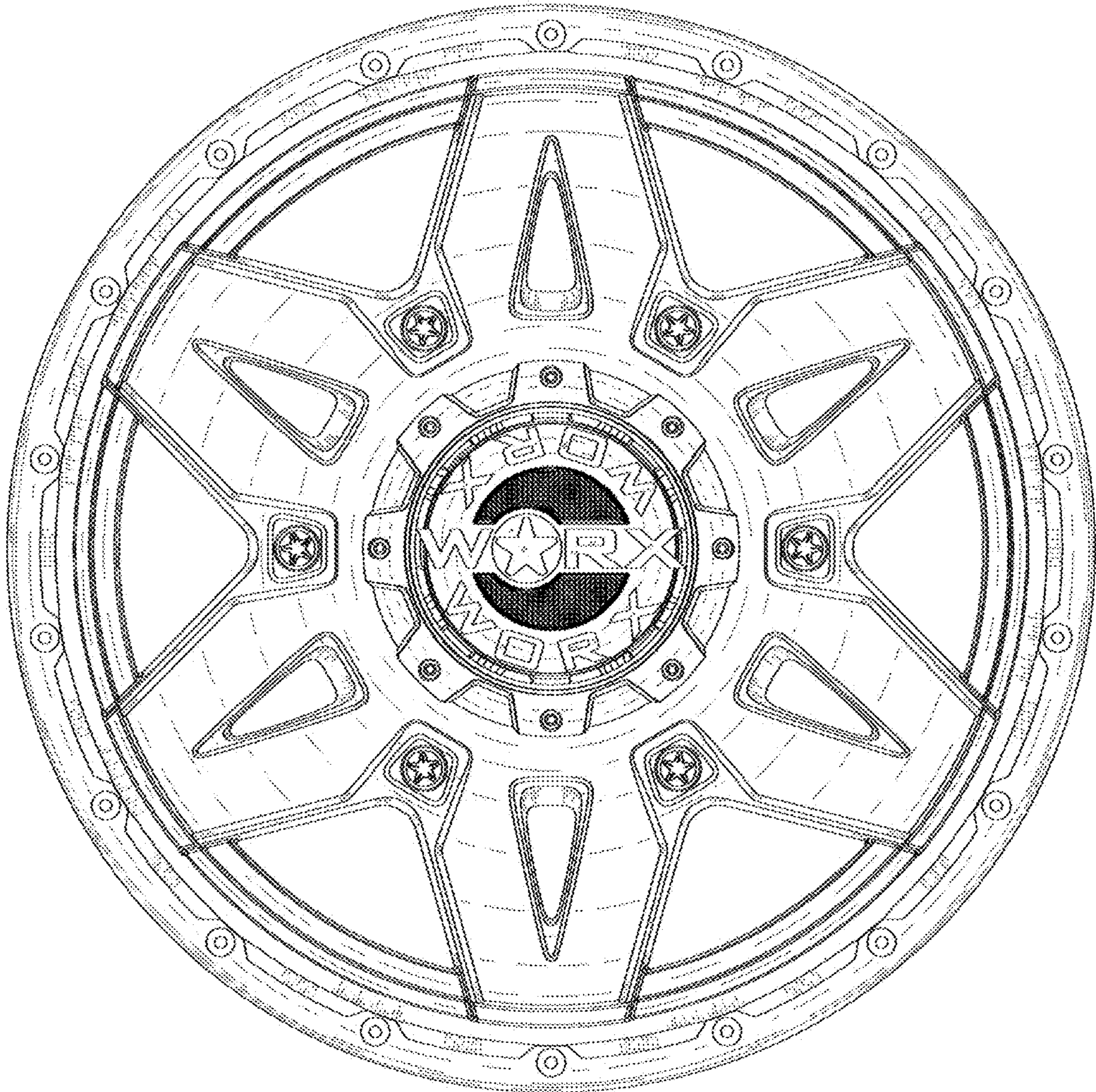

FIGURE 3

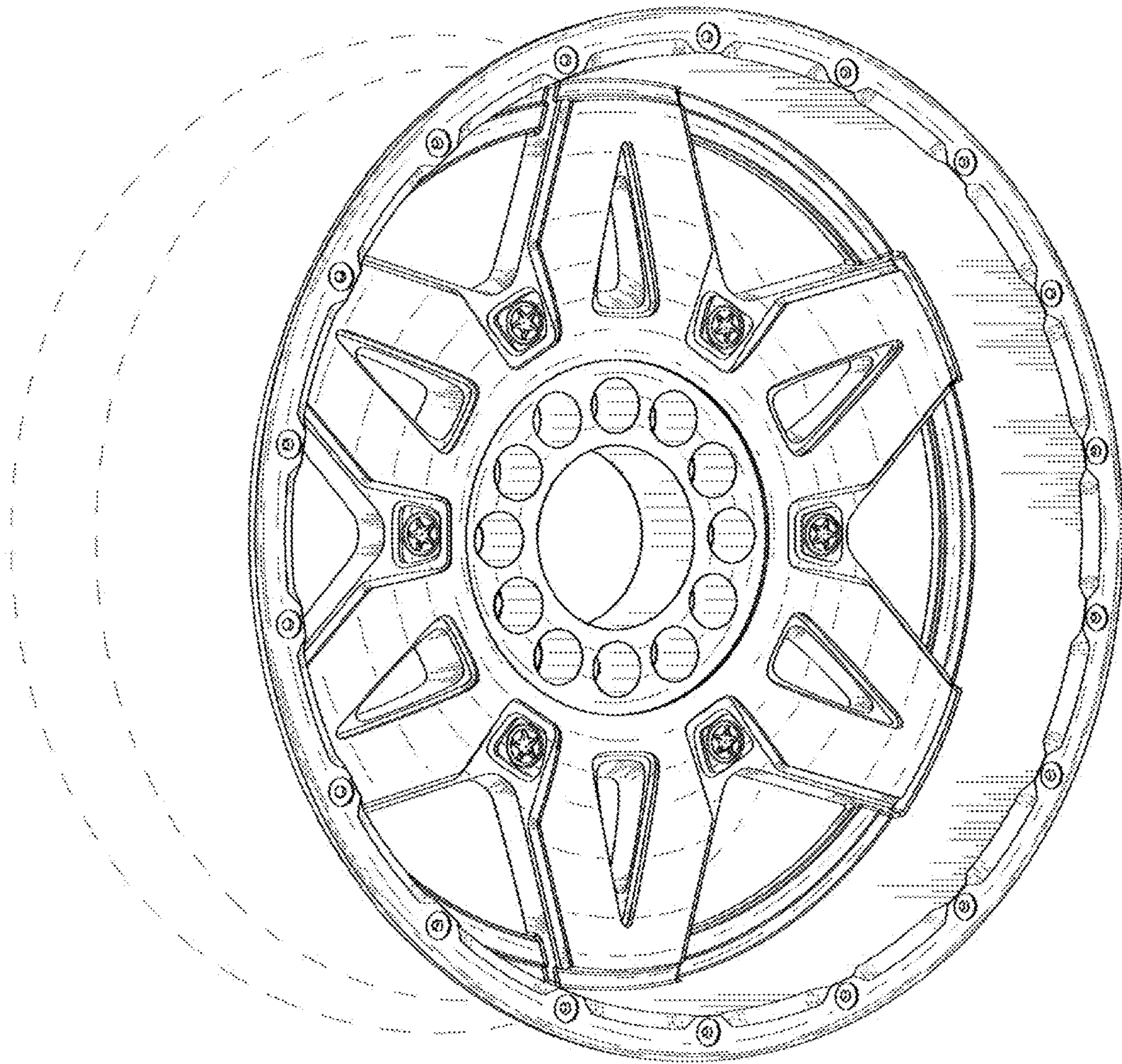

FIGURE 4

