



US00D737080S

(12) **United States Design Patent**
Mori

(10) **Patent No.:** **US D737,080 S**

(45) **Date of Patent:** **** Aug. 25, 2015**

(54) **PERCUSSION INSTRUMENT STAND**

8,367,919 B2 * 2/2013 Belitz et al. 84/453
2002/0100852 A1 * 8/2002 Eason et al. 248/292.12
2008/0135697 A1 * 6/2008 Workman et al. 248/177.1

(71) Applicant: **ROLAND CORPORATION**, Shizuoka
(JP)

OTHER PUBLICATIONS

(72) Inventor: **Yoshiaki Mori**, Shizuoka (JP)

Drum Workshop Inc., "http://www.dwdrums.com/smartpractice/specialty.asp", retrieved on Aug. 9, 2012, "dw smart practice:Go Anywhere TM 5-Piece Practice Set (DWCPPADTS5)", p. 1-2.

(73) Assignee: **ROLAND CORPORATION**, Shizuoka
(JP)

* cited by examiner

(**) Term: **14 Years**

Primary Examiner — Kelley Donnelly

(21) Appl. No.: **29/506,806**

(74) *Attorney, Agent, or Firm* — Jianq Chyun IP Office

(22) Filed: **Oct. 21, 2014**

(57) **CLAIM**

The ornamental design for a percussion instrument stand, as shown and described.

(30) **Foreign Application Priority Data**

DESCRIPTION

Jul. 2, 2014 (JP) 2014-014574

(51) **LOC (10) CL.** **06-06**

(52) **U.S. Cl.**
USPC **D6/682**

(58) **Field of Classification Search**
USPC D6/672–673, 678, 680, 682, 682.3;
D17/9, 20; D14/229, 447
CPC A47F 7/00; A47F 7/0042
See application file for complete search history.

FIG. 1 is a perspective view of a percussion instrument stand showing my new design;
FIG. 2 is a front view thereof;
FIG. 3 is a rear view thereof;
FIG. 4 is a left side view thereof;
FIG. 5 is a right side view thereof;
FIG. 6 is a top view thereof;
FIG. 7 is a bottom view thereof;
FIG. 8 is an enlarged view of an indicated portion of FIG. 2; and,
FIG. 9 is another perspective view thereof in an using state.
The dashed lines illustrating portions of the percussion instrument stand represent unclaimed portions of the claimed design and form no part thereof. The dot-dashed lines define boundaries of the claimed design and form no part thereof. The double dot-dashed lines shown in FIGS. 2 and 8 represents boundaries around portions of the percussion instrument stand that have been enlarged for clarity and form no part of the claimed design.

(56) **References Cited**

U.S. PATENT DOCUMENTS

D327,105 S * 6/1992 Smith, Jr. D21/691
5,165,635 A 11/1992 Hoshino
D414,962 S * 10/1999 Welsh D6/682
D435,365 S * 12/2000 Eason et al. D6/681
D473,058 S * 4/2003 Ingles D6/312
D475,555 S * 6/2003 Lauts D6/682
D534,741 S * 1/2007 Lippert D6/682
D613,092 S * 4/2010 Eason et al. D6/682
D664,374 S * 7/2012 Capella D6/681.3

1 Claim, 9 Drawing Sheets

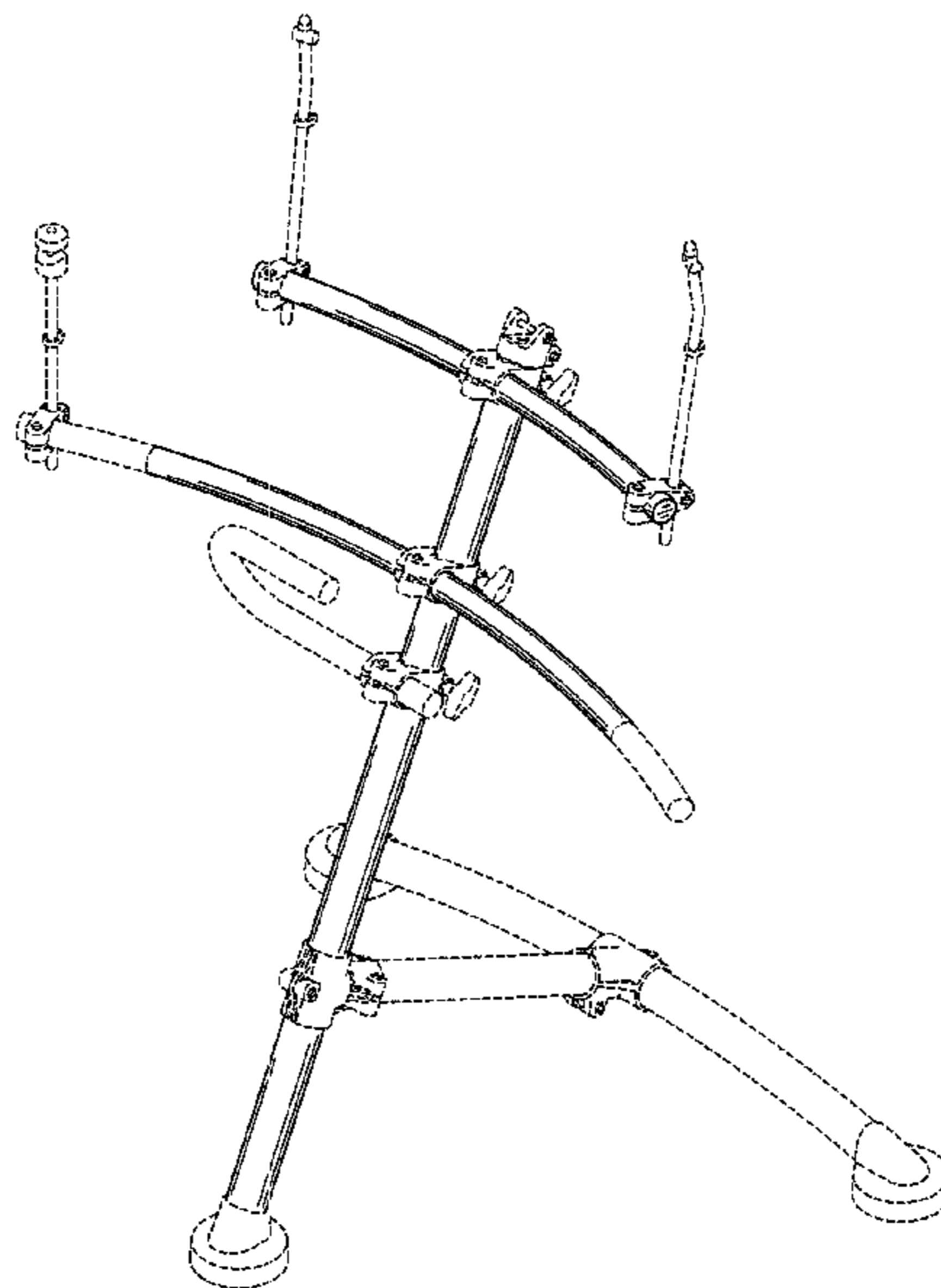

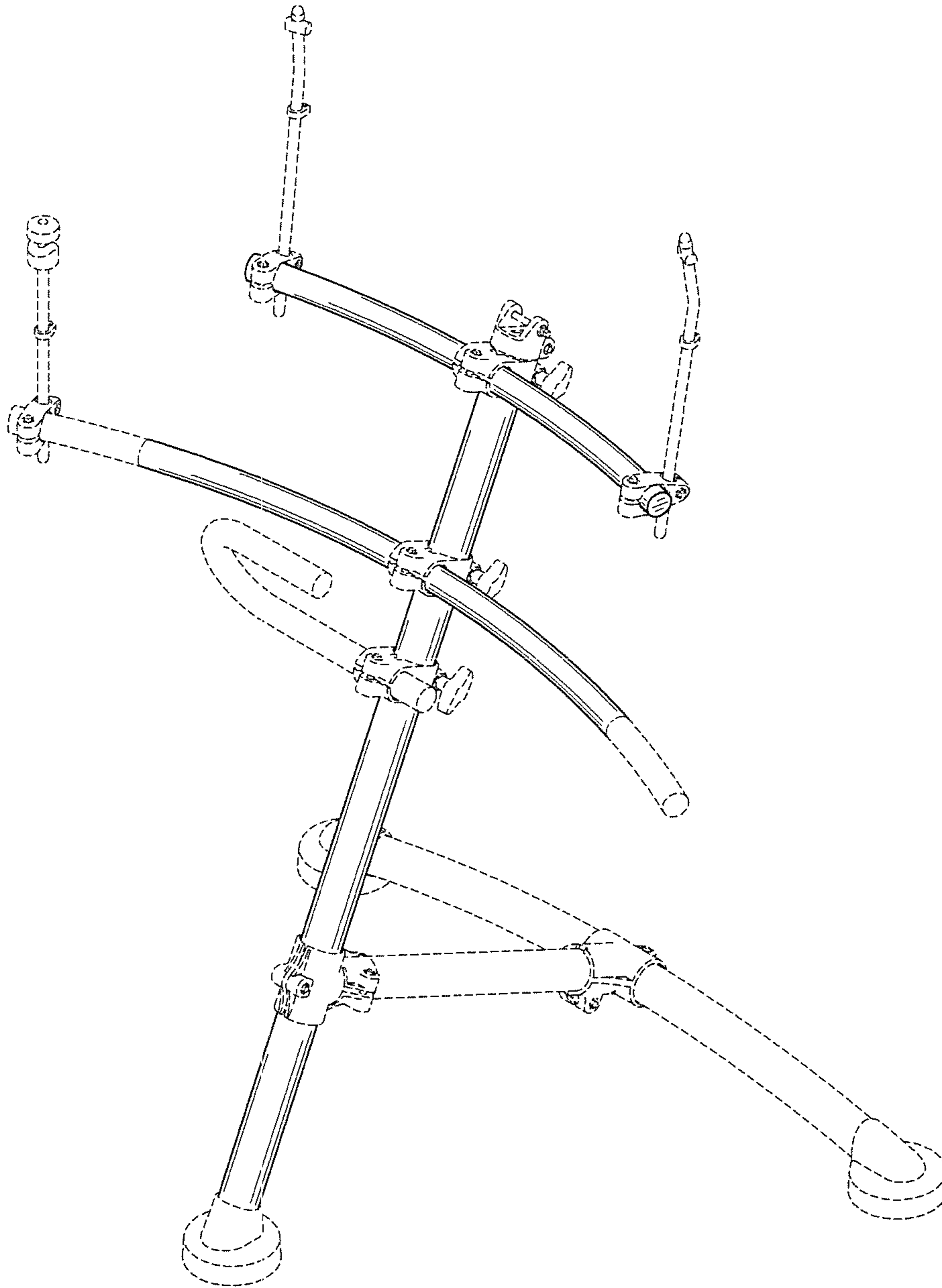

FIG. 1

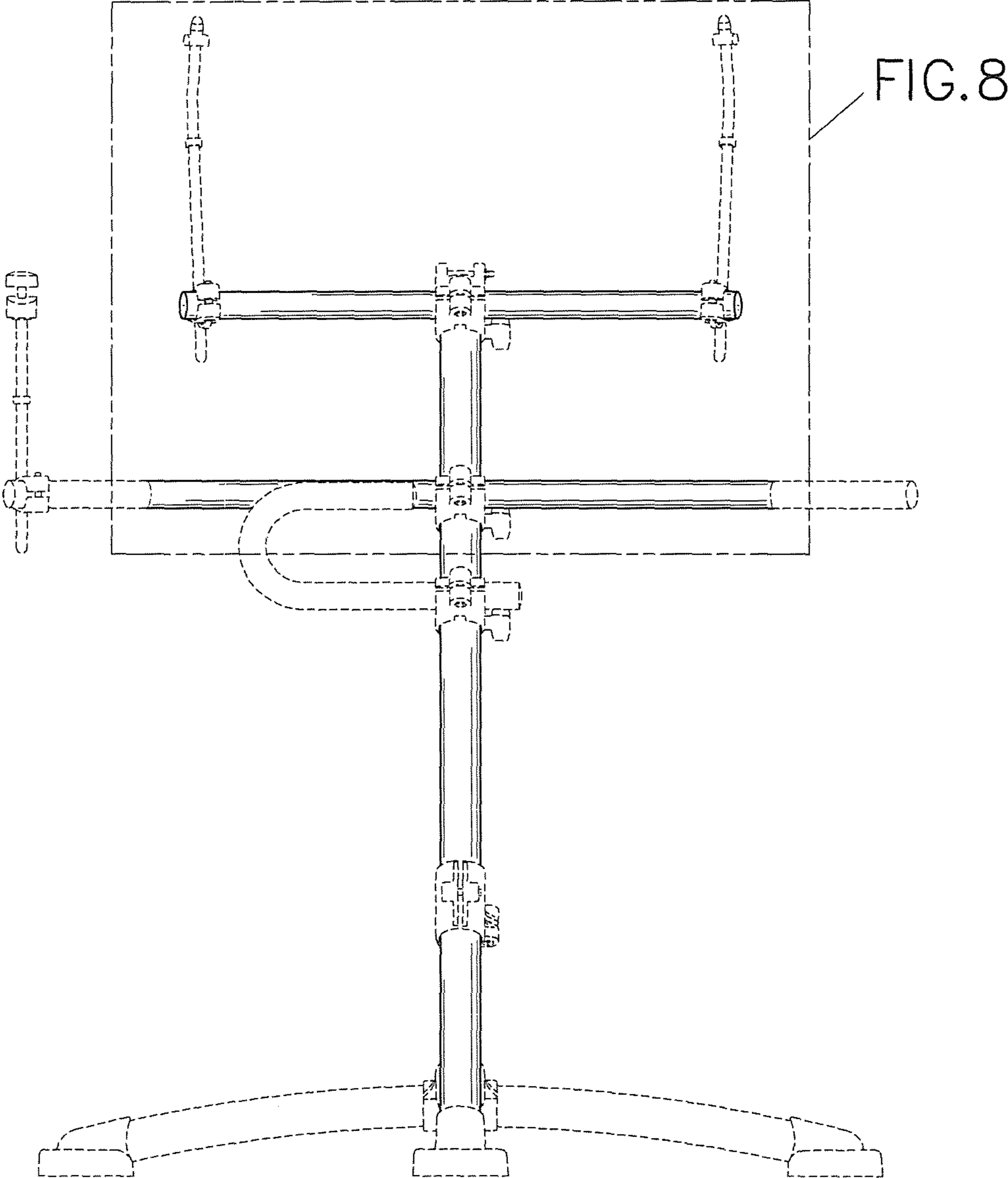

FIG. 2

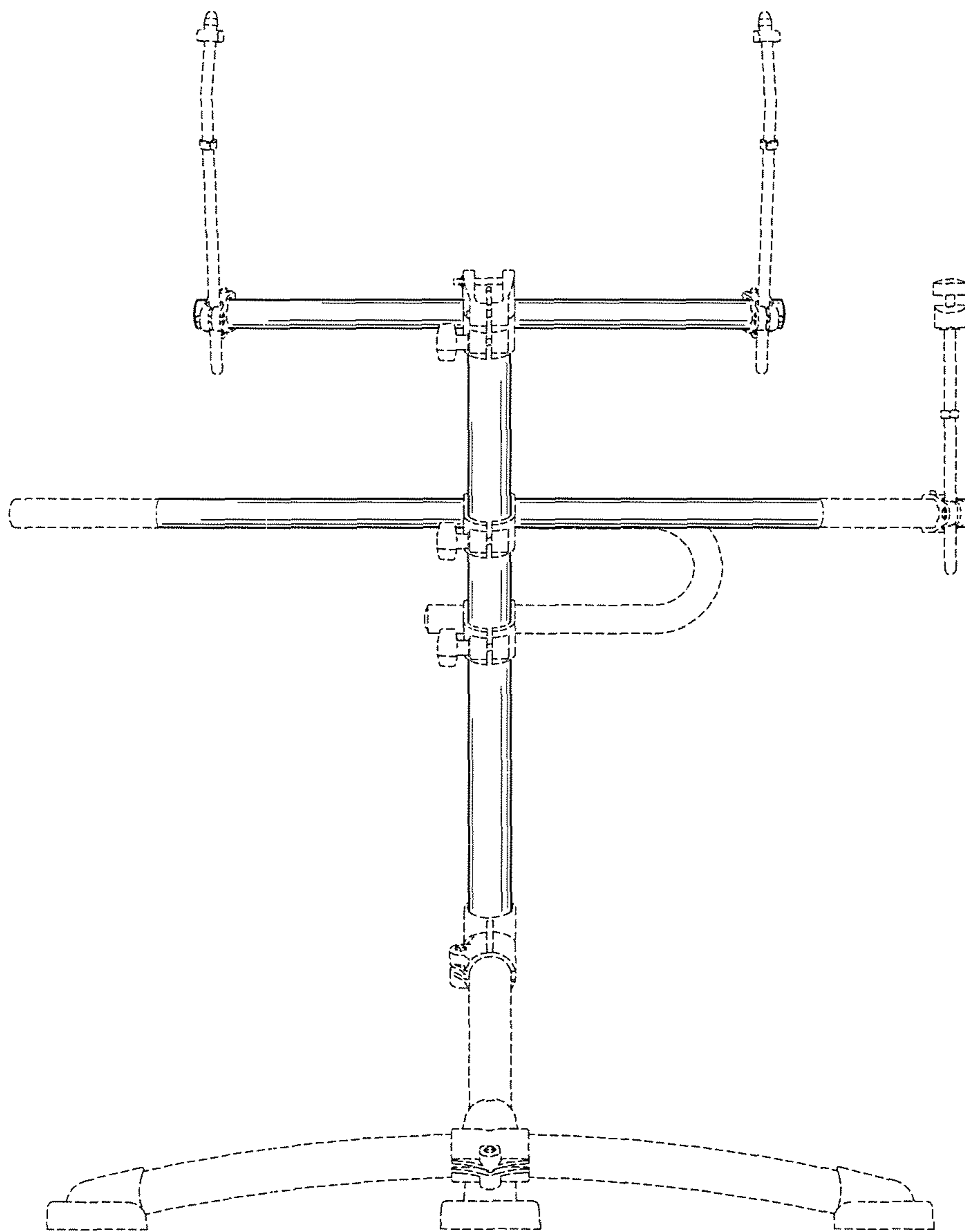

FIG. 3

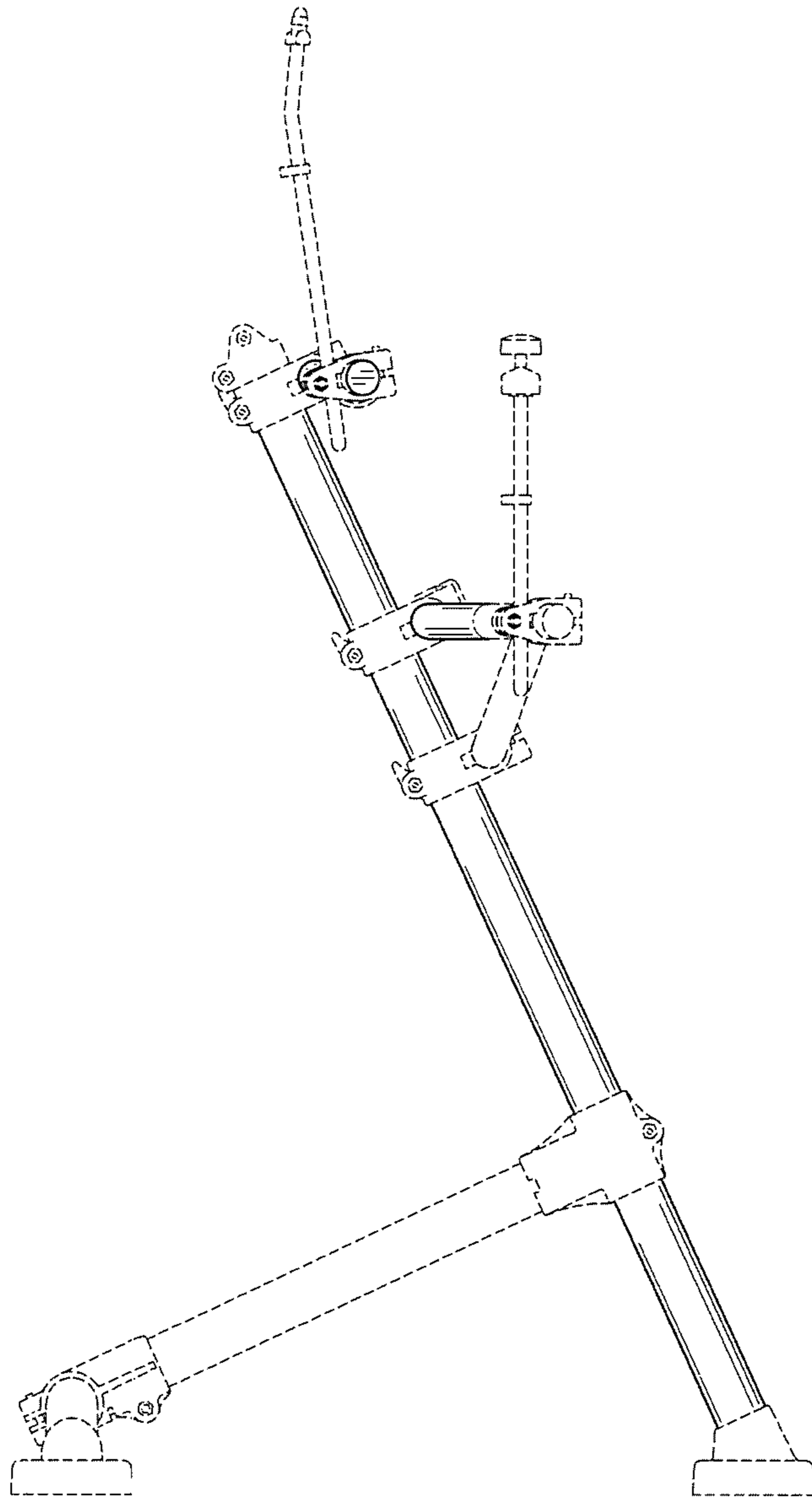

FIG. 4

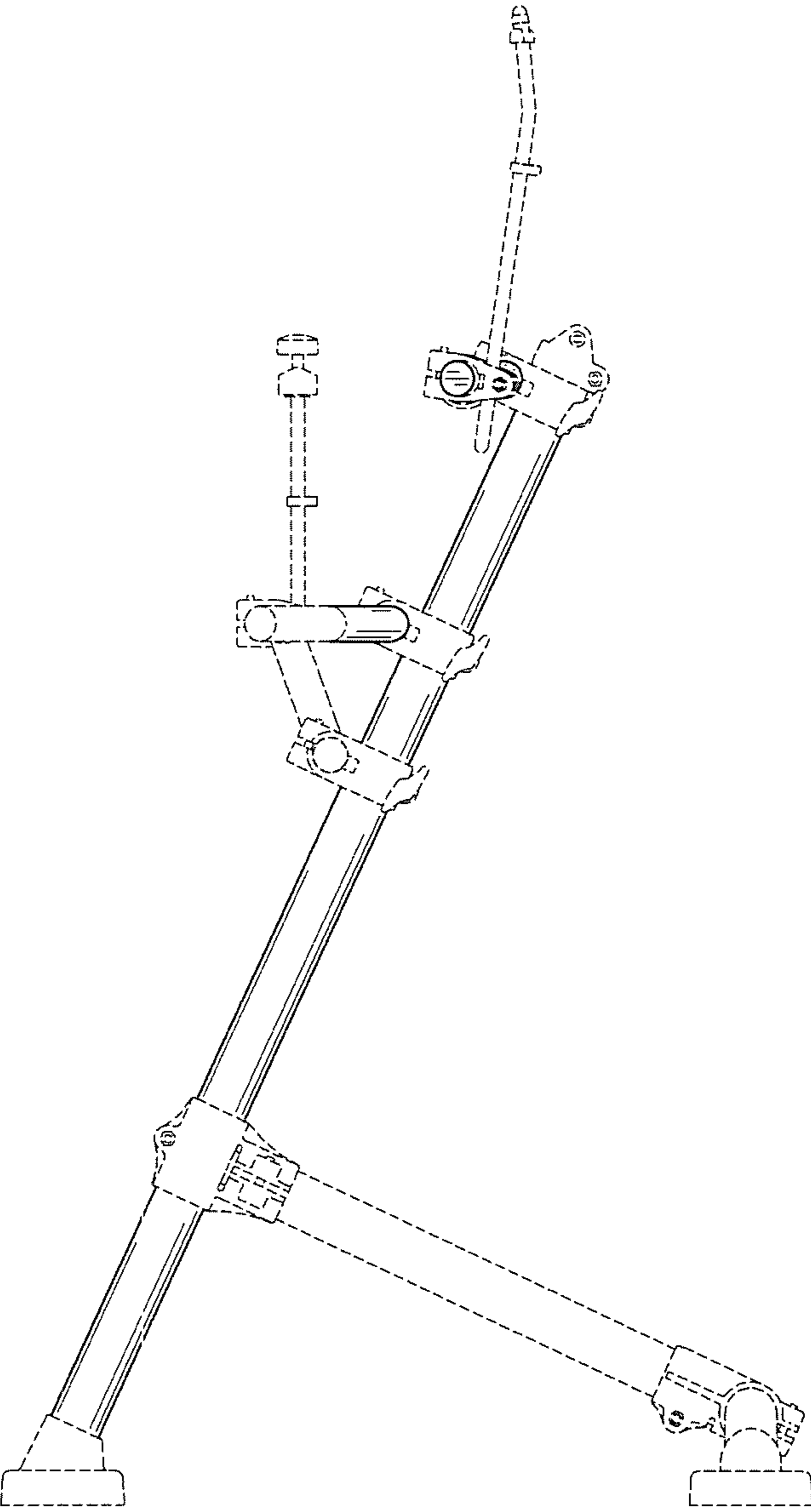

FIG. 5

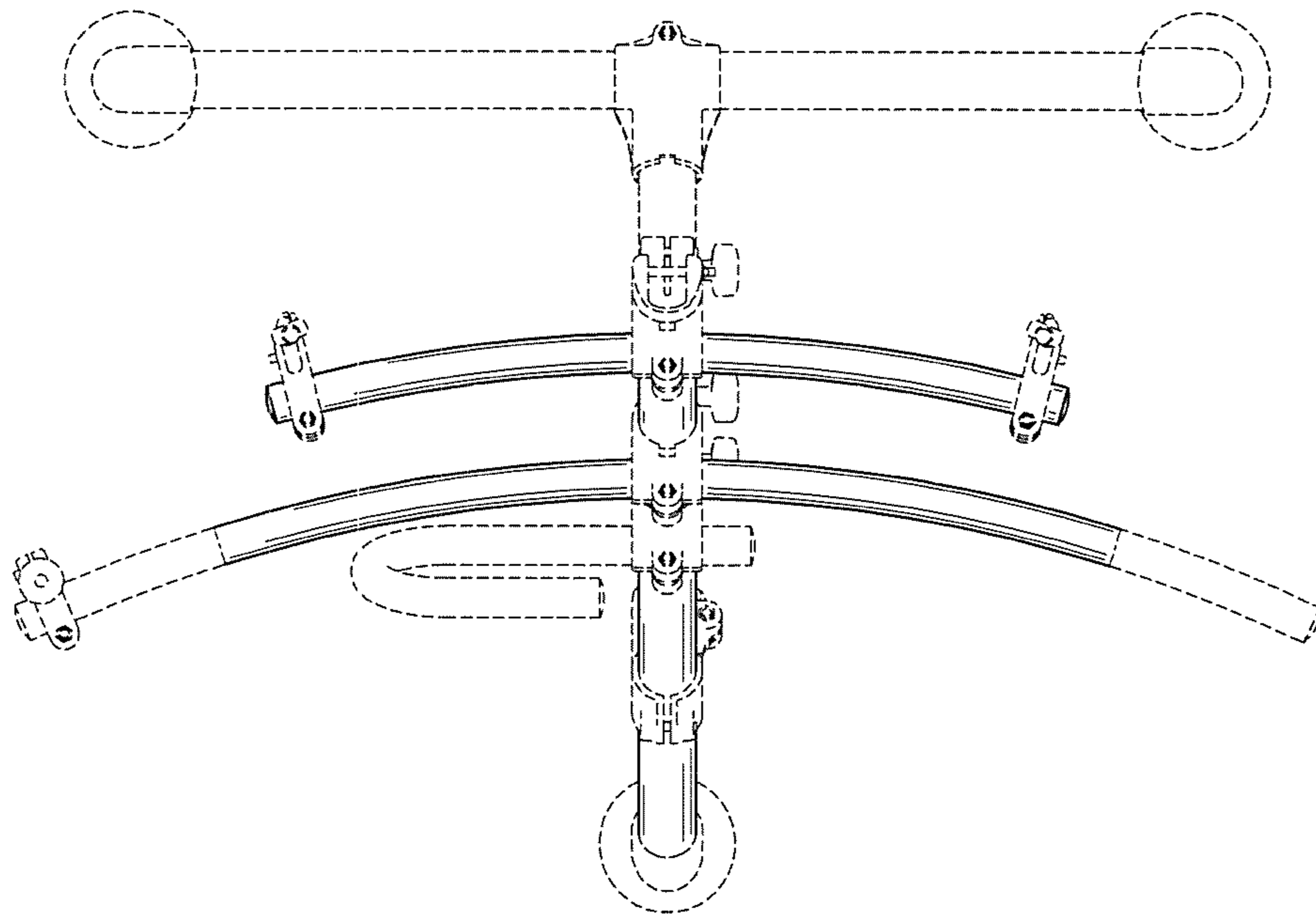

FIG. 6

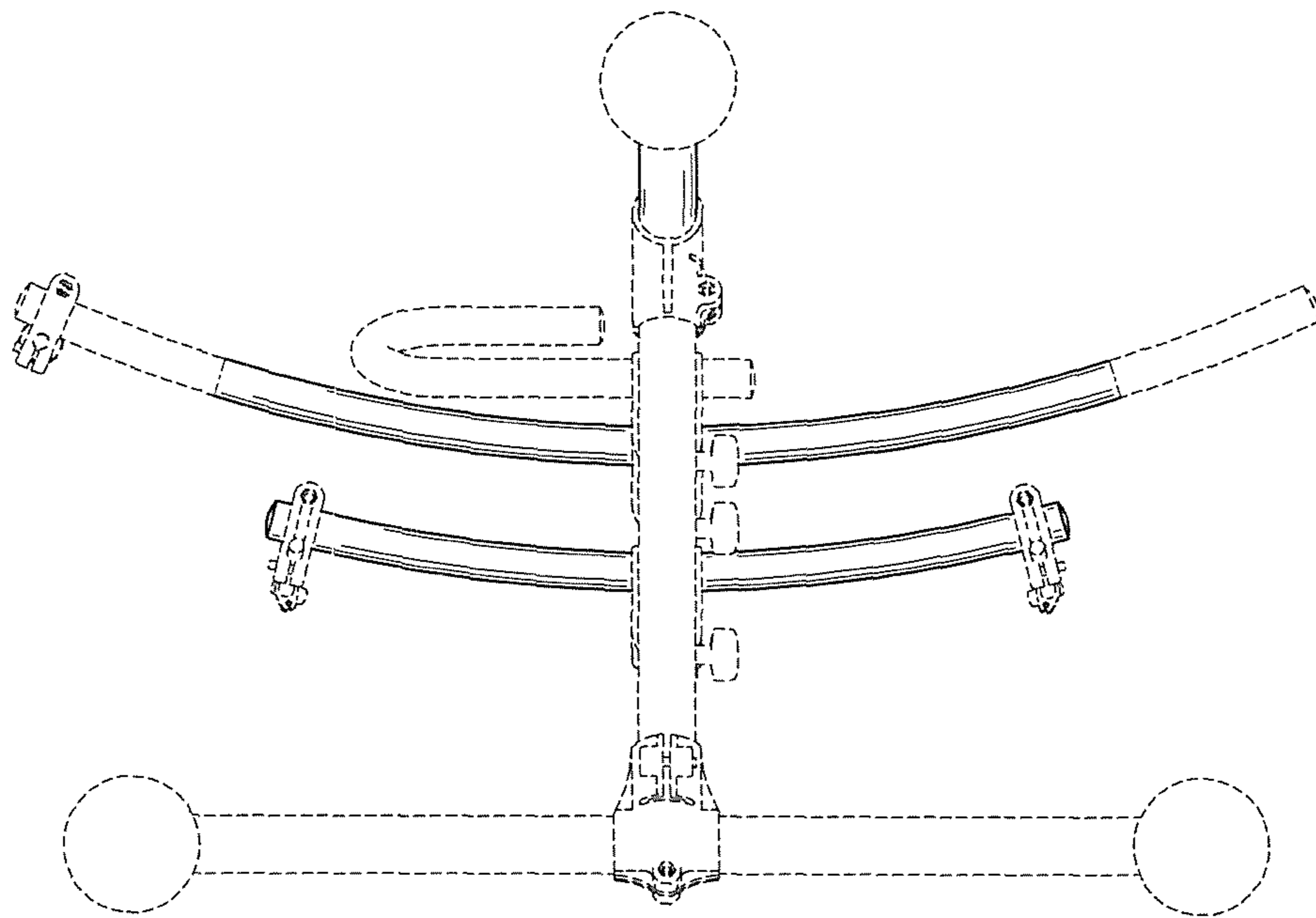

FIG. 7

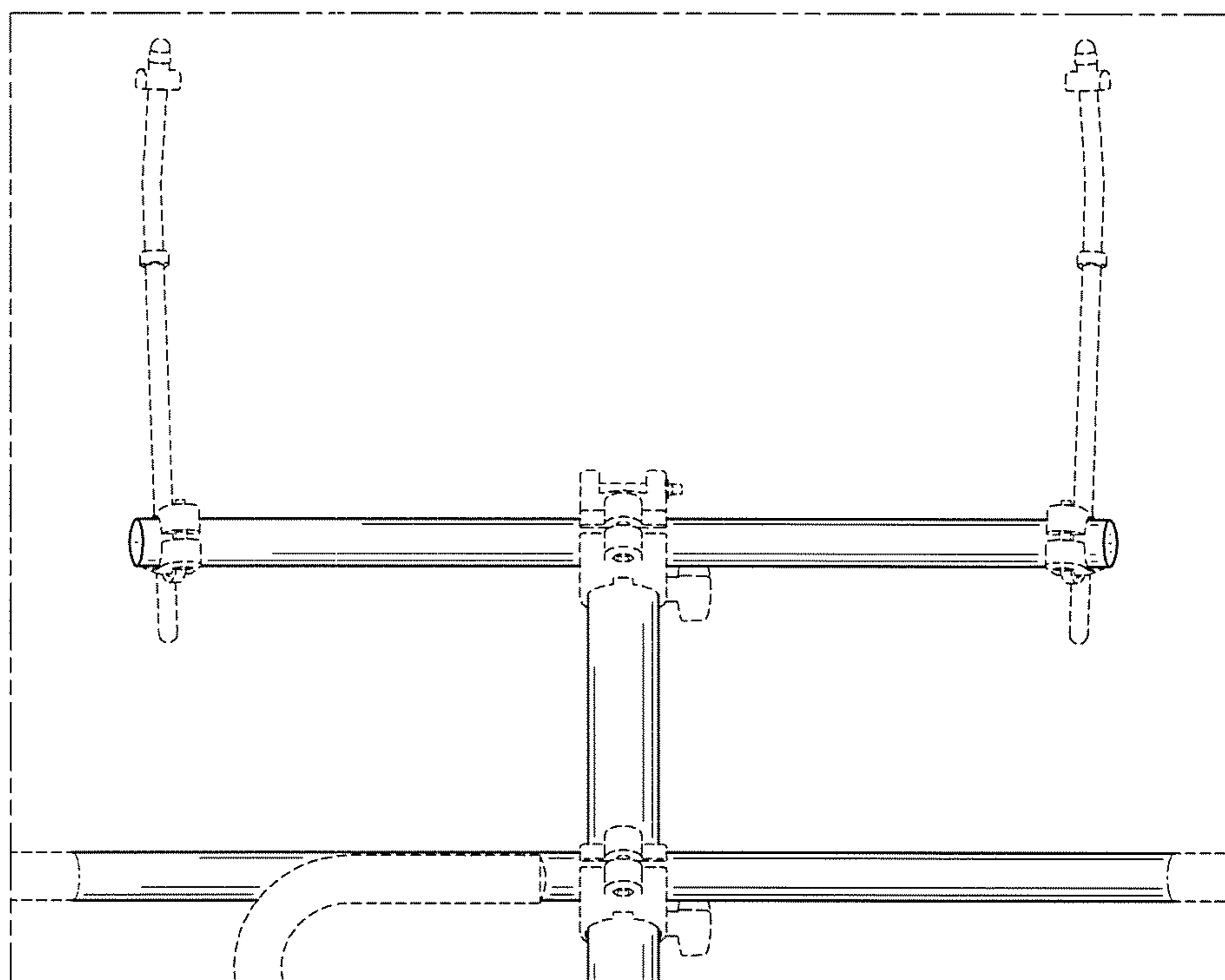

FIG. 8

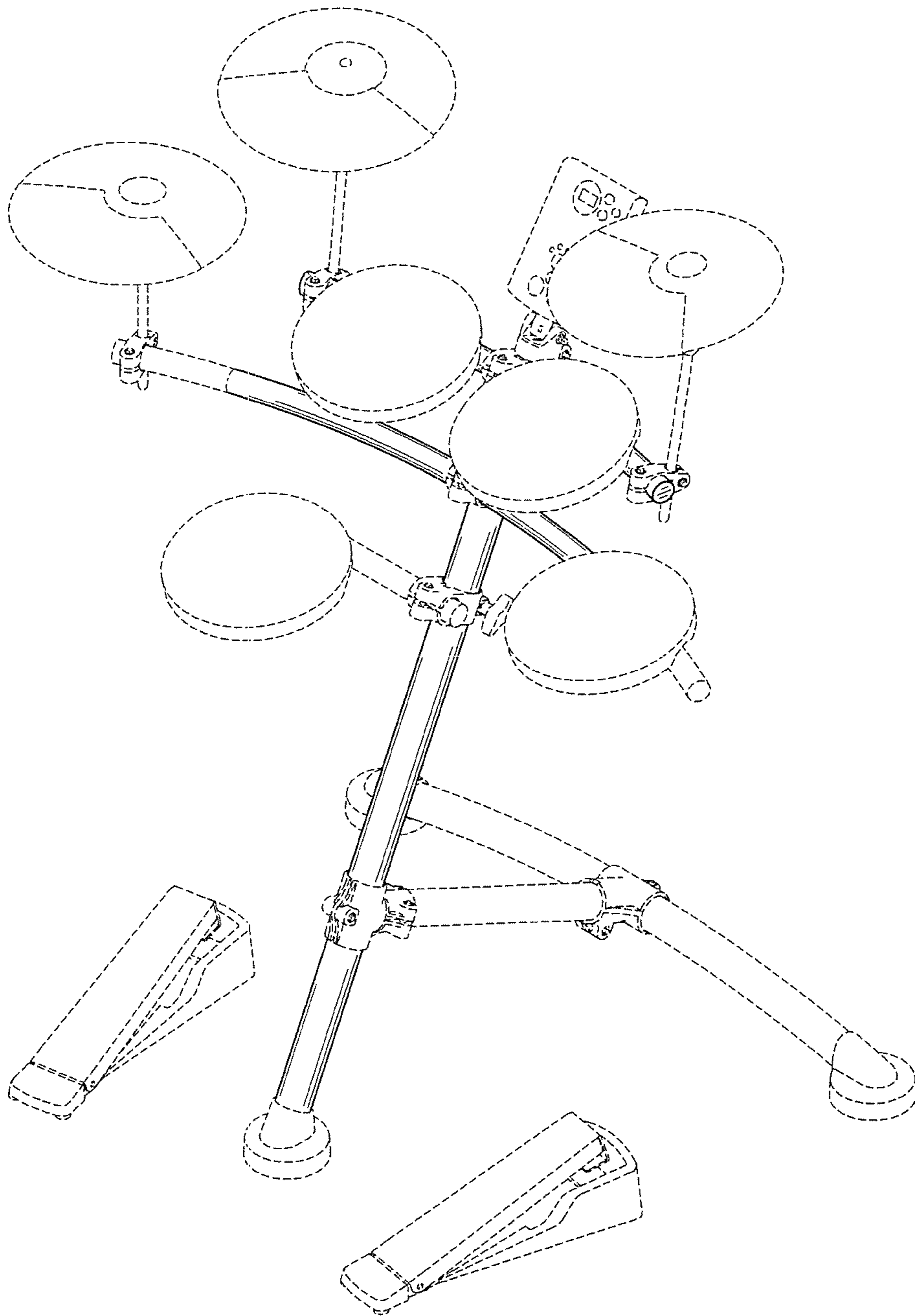

FIG. 9