



US00D736896S

(12) **United States Design Patent**
Nishimura

(10) **Patent No.:** **US D736,896 S**

(45) **Date of Patent:** **** Aug. 18, 2015**

(54) **FLOW-RATE CONTROL VALVE**

(71) Applicant: **SMC CORPORATION**, Tokyo (JP)

(72) Inventor: **Akiho Nishimura**, Moriya (JP)

(73) Assignee: **SMC CORPORATION**, Tokyo (JP)

(**) Term: **14 Years**

(21) Appl. No.: **29/502,089**

(22) Filed: **Sep. 11, 2014**

(51) **LOC (10) Cl.** **23-01**

(52) **U.S. Cl.**
USPC **D23/233**

(58) **Field of Classification Search**

USPC D23/233-269; 137/498, 545, 547, 549,
137/377, 614.17; 251/62, 63, 63.5, 129.01,
251/129.1, 129.16-129.18, 368, 205, 208,
251/215, 309-310, 312, 904, 311

CPC F16K 47/08; F16K 15/188; F16K 31/12;
F16K 5/10; F16K 11/0716; F16K 11/0853

See application file for complete search history.

(56) **References Cited**

U.S. PATENT DOCUMENTS

D476,718 S * 7/2003 Ferrer Beltran D23/209

D519,188 S * 4/2006 Hay D23/233

(Continued)

FOREIGN PATENT DOCUMENTS

JP D1337900 S 8/2008

JP D1368781 S 9/2009

OTHER PUBLICATIONS

Orbit Website Search, Jun. 3, 2015, 1/3 China Orbit-RGN
303182542, shown in p. 1.*

(Continued)

Primary Examiner — Cynthia Ramirez

Assistant Examiner — Gino Colan

(74) *Attorney, Agent, or Firm* — Birch, Stewart, Kolasch &
Birch, LLP

(57) **CLAIM**

The ornamental design for a flow-rate control valve, as
shown.

DESCRIPTION

FIG. 1 is a front, top and left side perspective view of a
flow-rate control valve showing a first embodiment of my
new design;

FIG. 2 is a front view thereof;

FIG. 3 is a rear view thereof;

FIG. 4 is a top plan view thereof;

FIG. 5 is a bottom plan view thereof;

FIG. 6 is a left side view thereof;

FIG. 7 is a right side view thereof;

FIG. 8 is a front, top and right side perspective view of a
flow-rate control valve showing a second embodiment of my
new design;

FIG. 9 is a front view thereof;

FIG. 10 is a rear view thereof;

FIG. 11 is a top plan view thereof;

FIG. 12 is a bottom plan view thereof;

FIG. 13 is a left side view thereof;

FIG. 14 is a right side view thereof;

FIG. 15 is a rear, top and right side perspective view of a
flow-rate control valve showing a third embodiment of my
new design;

FIG. 16 is a front view thereof;

FIG. 17 is a rear view thereof;

FIG. 18 is a top plan view thereof;

FIG. 19 is a bottom plan view thereof;

FIG. 20 is a left side view thereof;

FIG. 21 is a right side view thereof;

FIG. 22 is a rear, top and left side perspective view of a
flow-rate control valve showing a fourth embodiment of my
new design;

FIG. 23 is a front view thereof;

FIG. 24 is a rear view thereof;

FIG. 25 is a top plan view thereof;

FIG. 26 is a bottom plan view thereof;

FIG. 27 is a left side view thereof; and,

FIG. 28 is a right side view thereof.

1 Claim, 28 Drawing Sheets

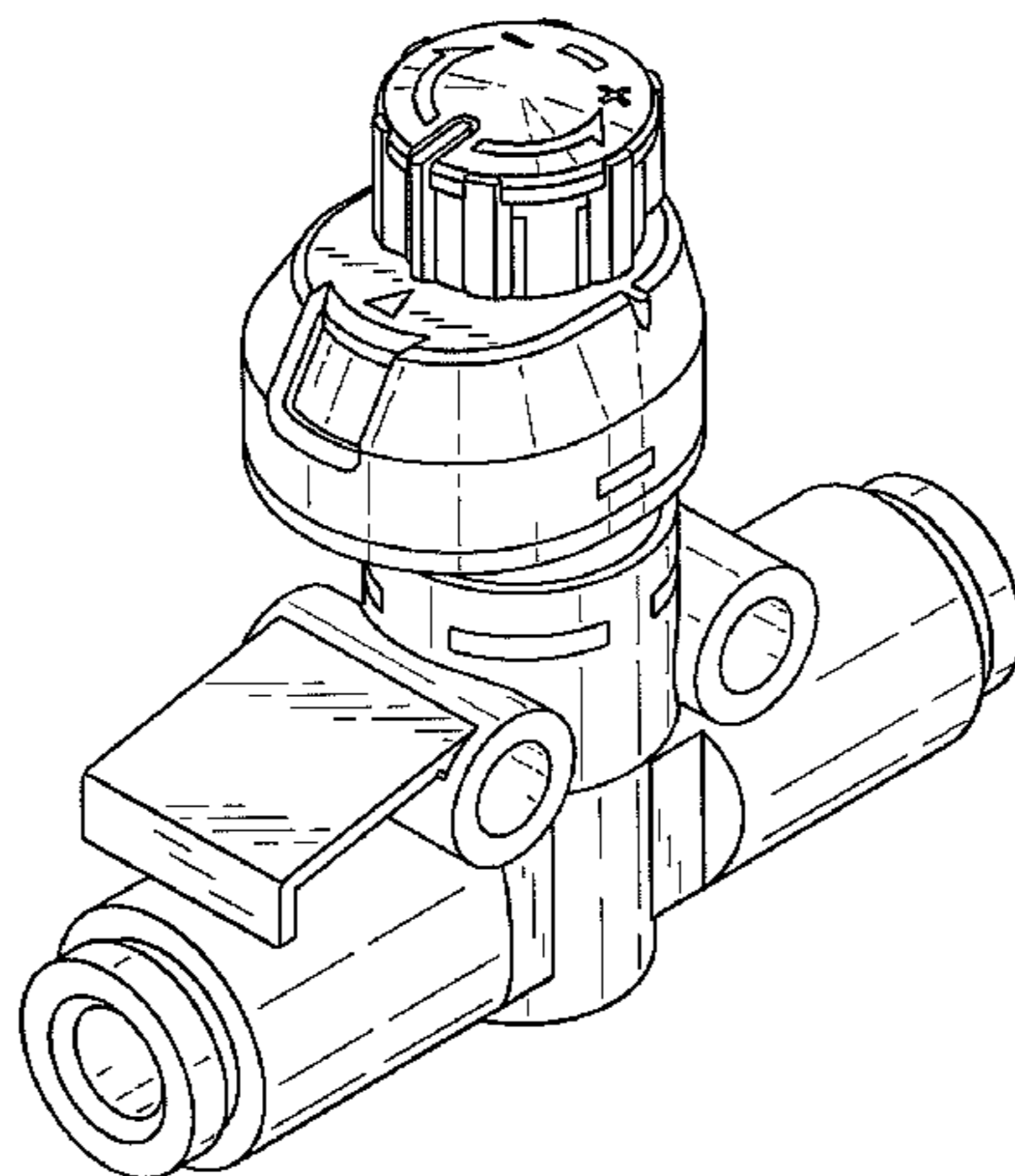

(56)

References Cited

U.S. PATENT DOCUMENTS

D600,779 S * 9/2009 Shishido D23/233
D600,780 S * 9/2009 Shishido D23/233
D623,271 S * 9/2010 Yamada D23/233
D623,272 S * 9/2010 Cavagna D23/233
D633,180 S * 2/2011 Duong et al. D23/233
D639,392 S * 6/2011 Yamada D23/233
D646,753 S * 10/2011 Juul et al. D23/233
D652,121 S * 1/2012 Bonhag et al. D23/263
D667,930 S * 9/2012 Yamada D23/235
D678,981 S * 3/2013 Shengyong D23/233
D692,983 S * 11/2013 Nissen et al. D23/233
D697,587 S * 1/2014 Nissen et al. D23/233

D699,815 S * 2/2014 Petersen D23/233
8,839,817 B2 * 9/2014 Dederich et al. 137/614.17
D720,048 S * 12/2014 Winborn D23/233
D722,362 S * 2/2015 Kluss et al. D23/235
D722,363 S * 2/2015 Kluss et al. D23/235
2010/0288952 A1 * 11/2010 Christensen 251/129.15
2011/0233437 A1 * 9/2011 Mattson et al. 251/309

OTHER PUBLICATIONS

Orbit Website Search, Jun. 3, 2015, 2/3 China Orbit (2)-RGN
303102687, shown in p. 1.*
Orbit Website Search, Jun. 3, 2015 3/3 Japan Orbit-RGN D1520214,
shown in p. 1.*

* cited by examiner

FIG. 1

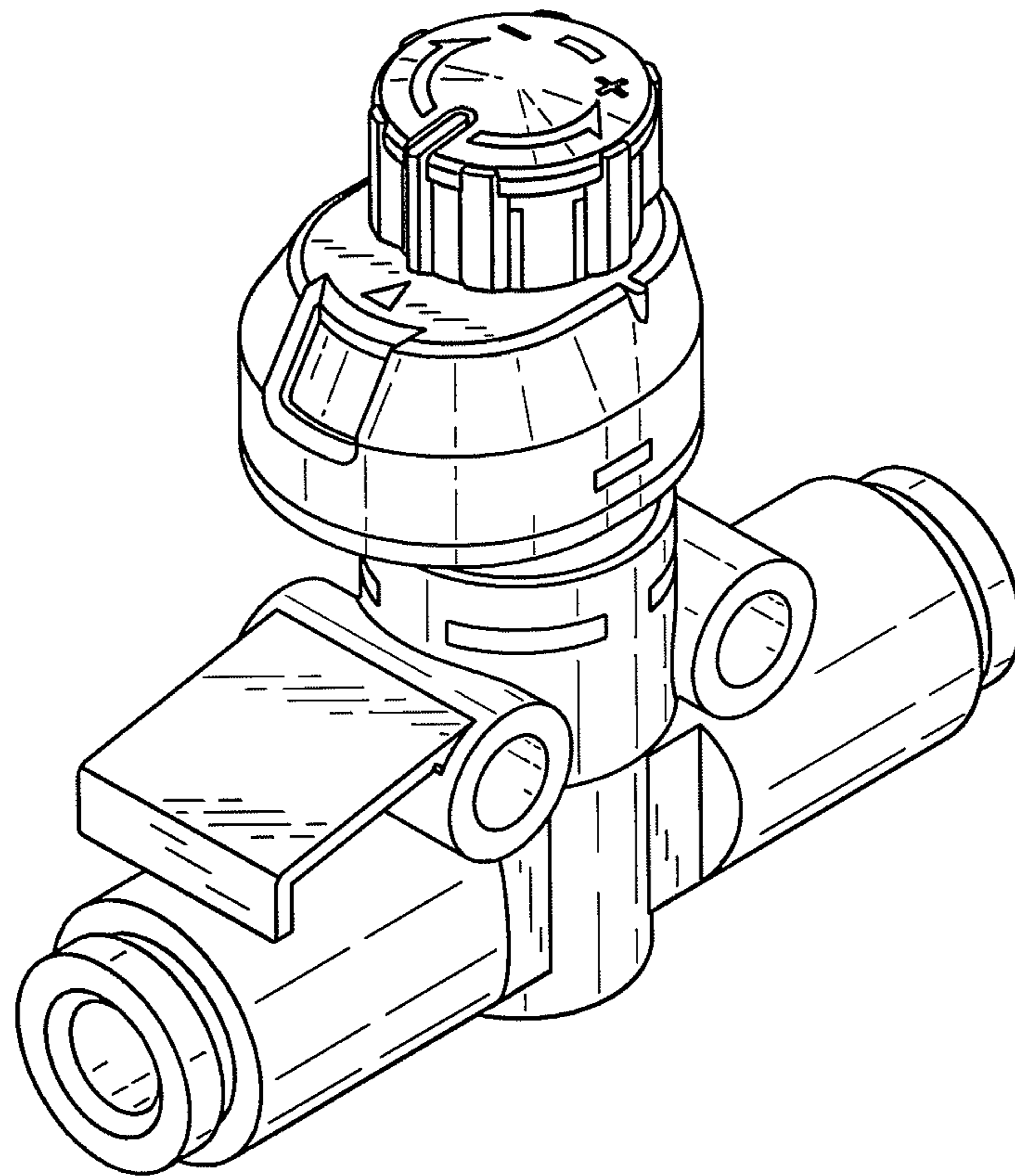

FIG. 2

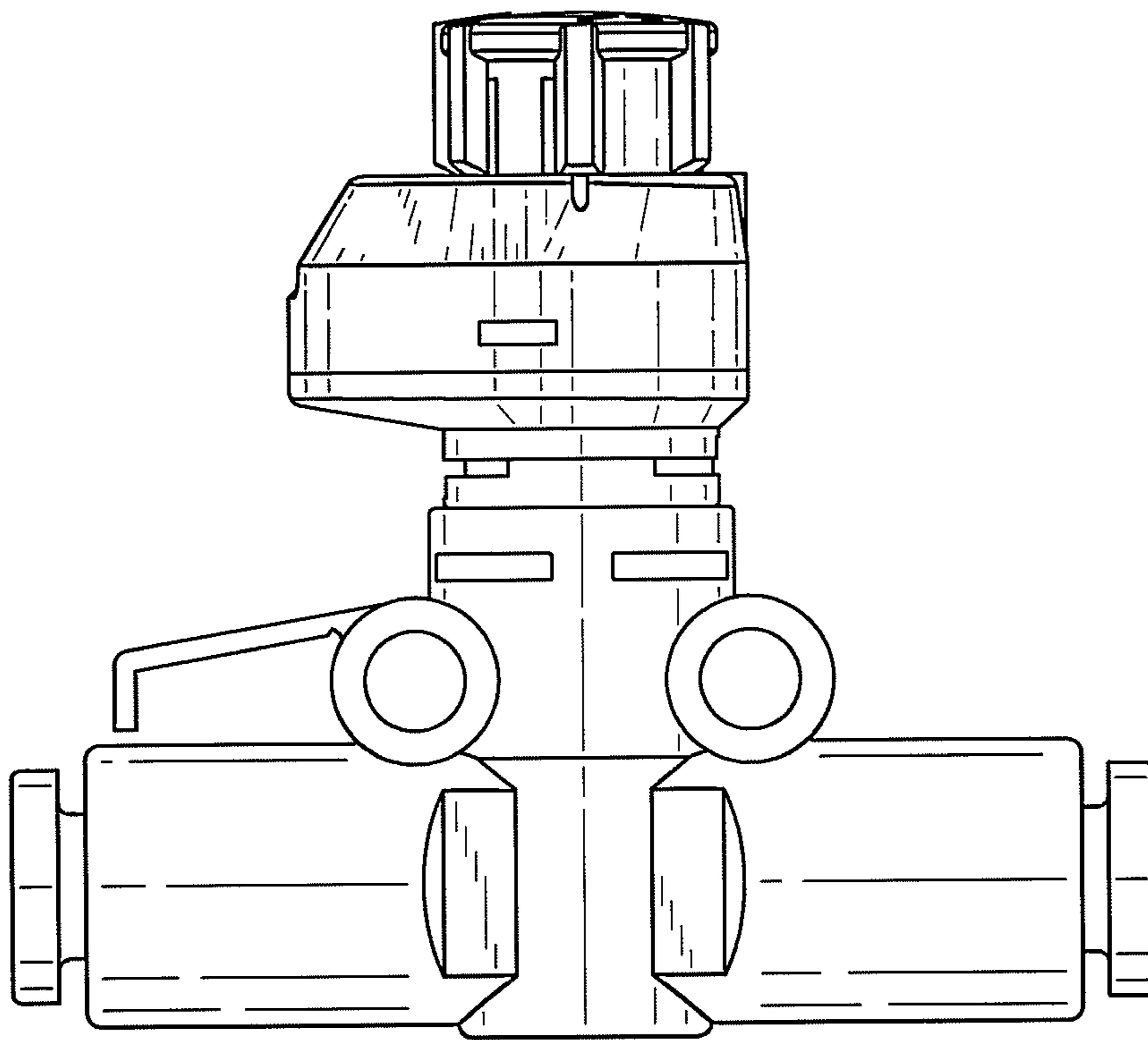

FIG. 3

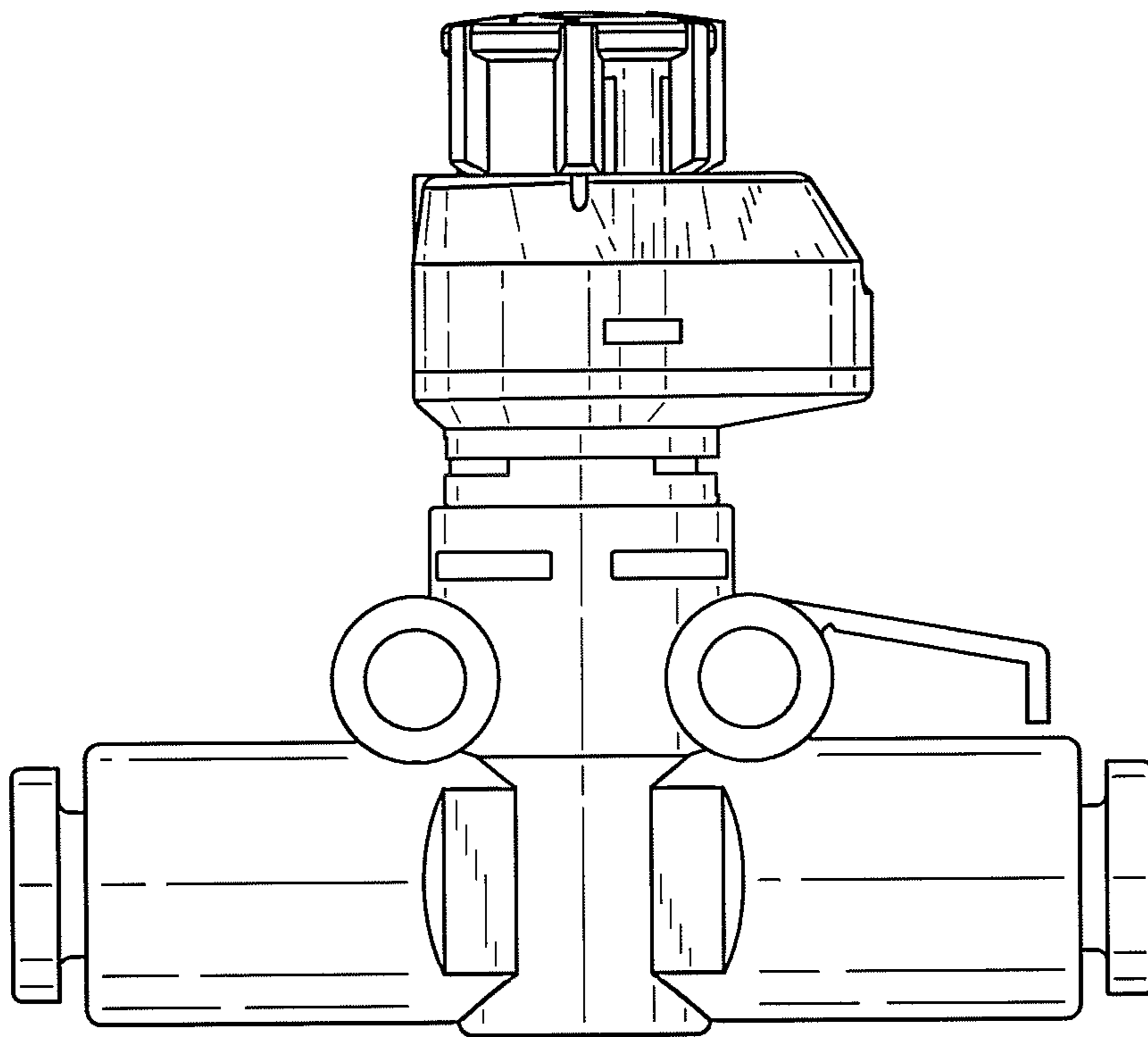

FIG. 4

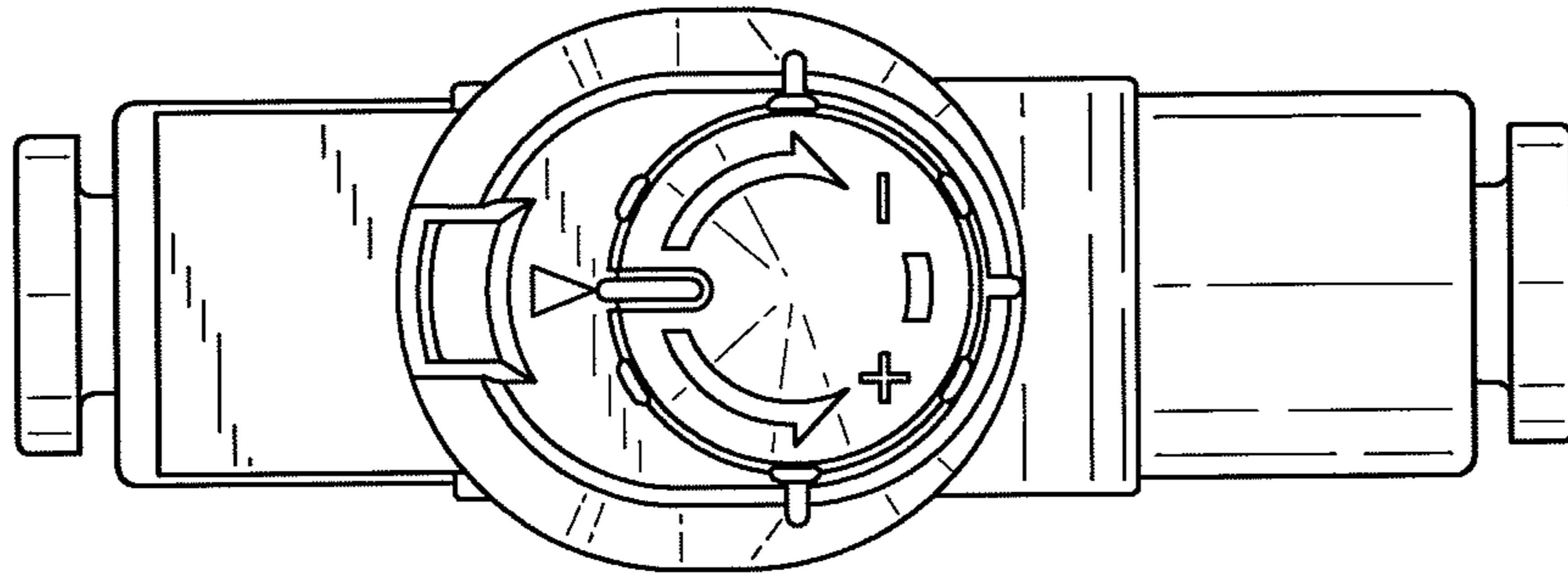

FIG. 5

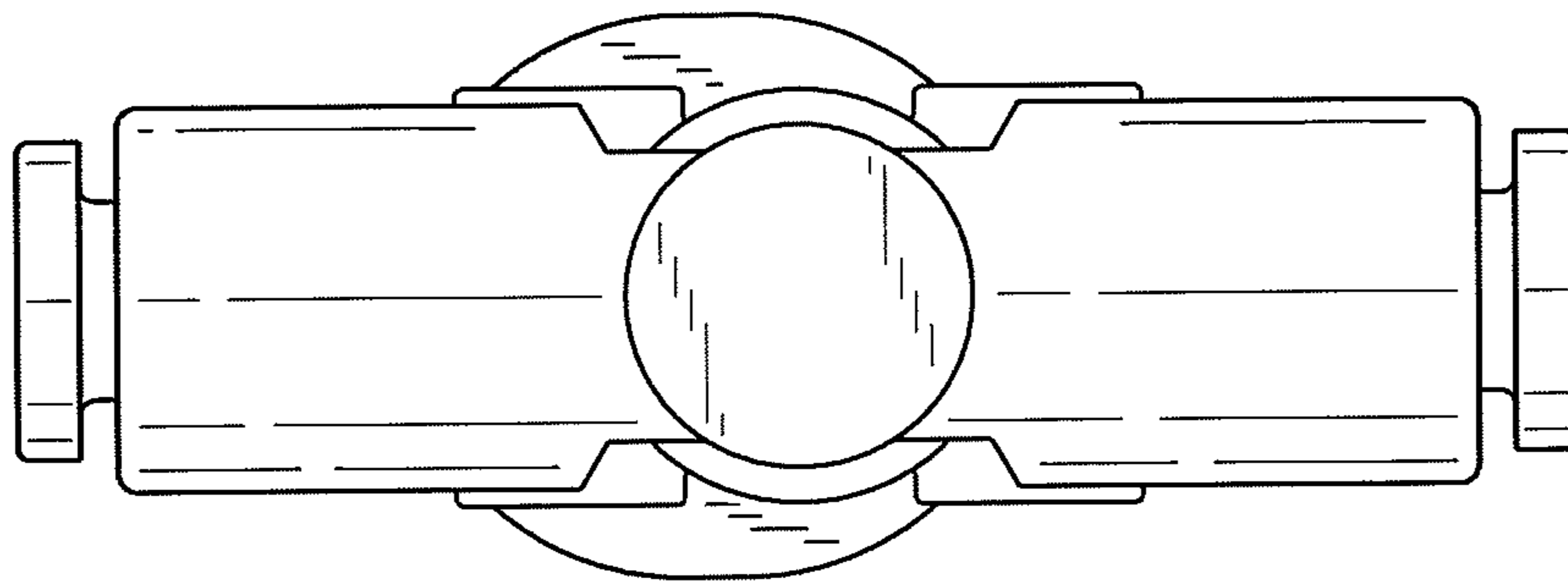

FIG. 6

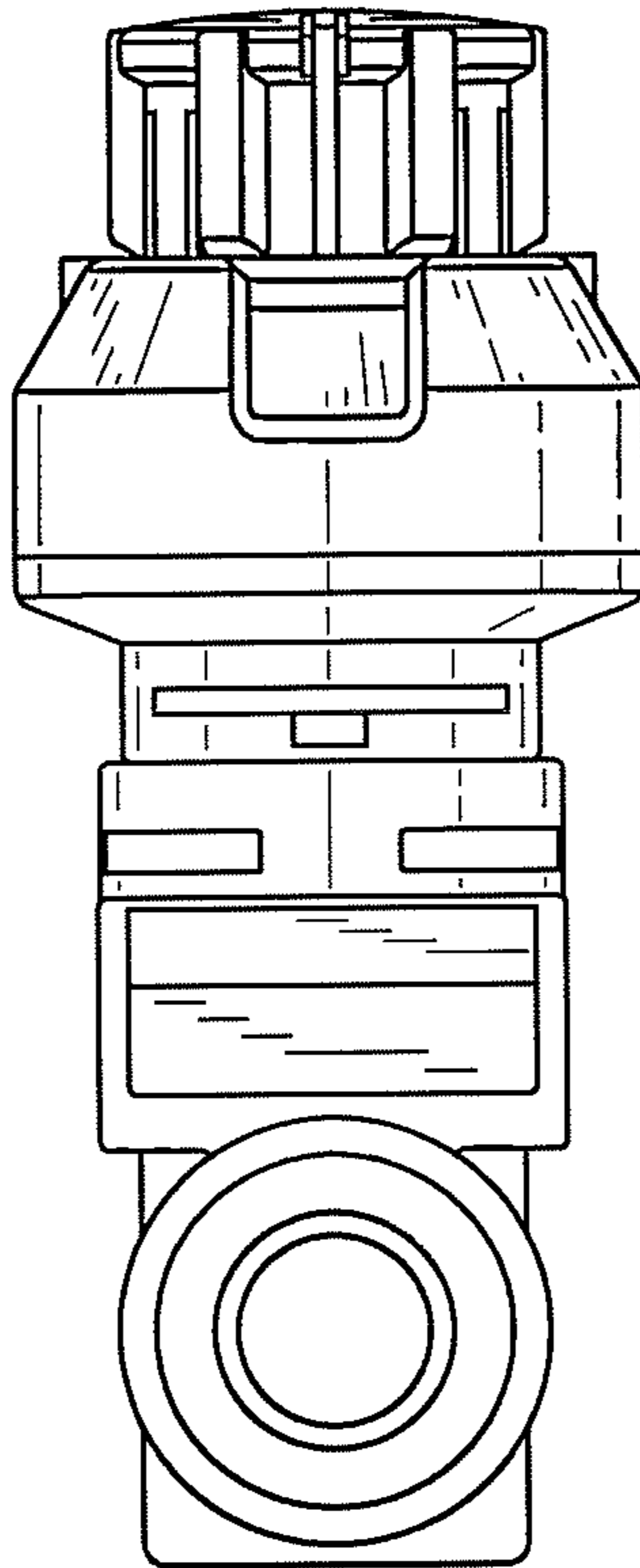

FIG. 7

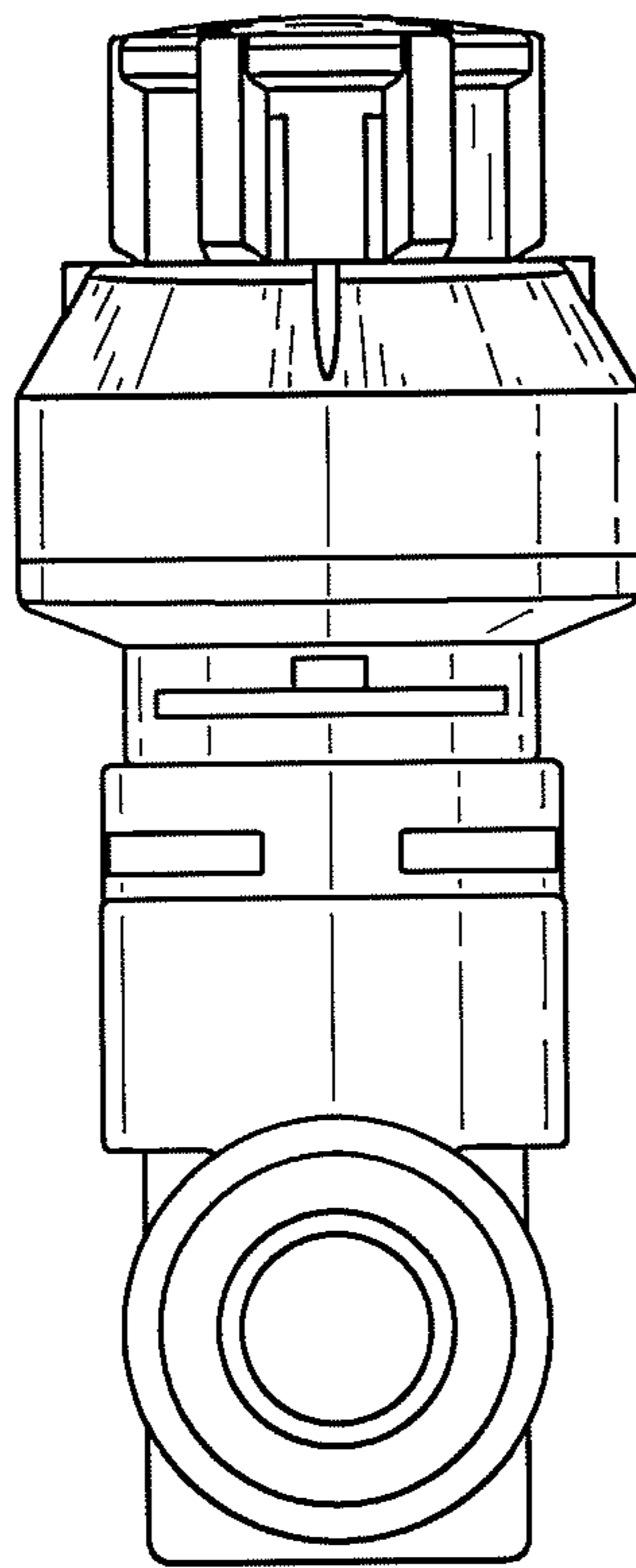

FIG. 8

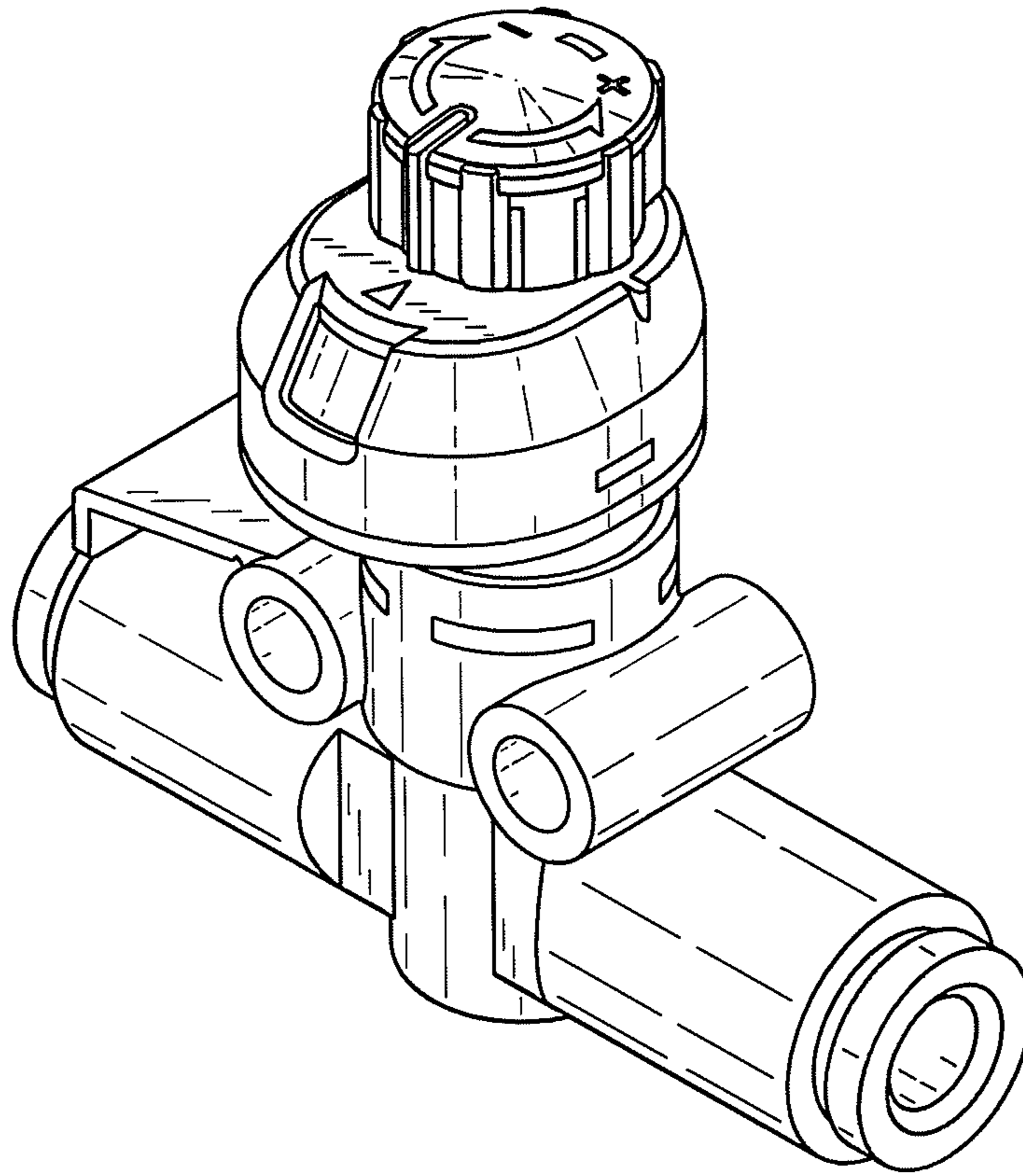

FIG. 9

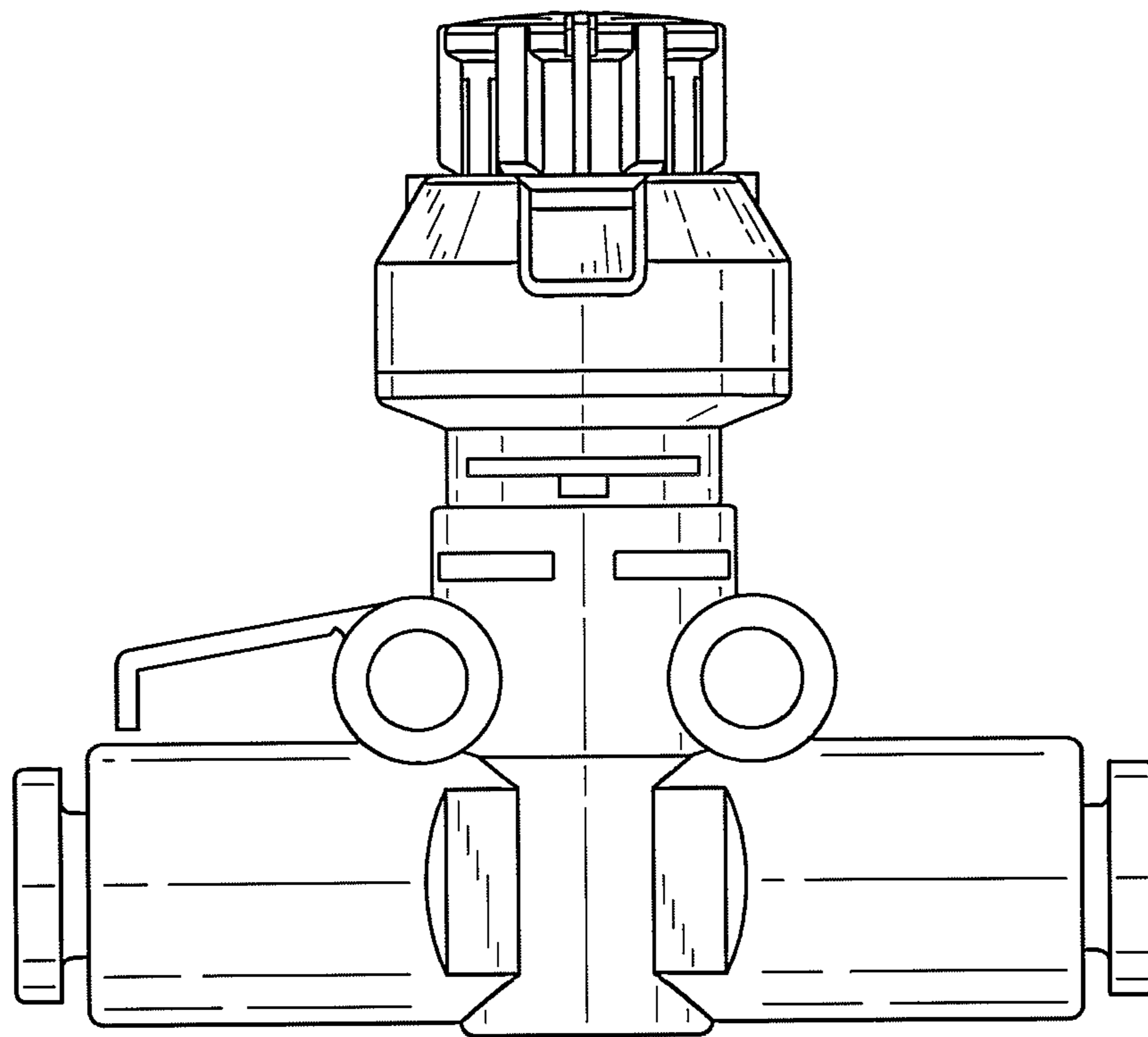

FIG. 10

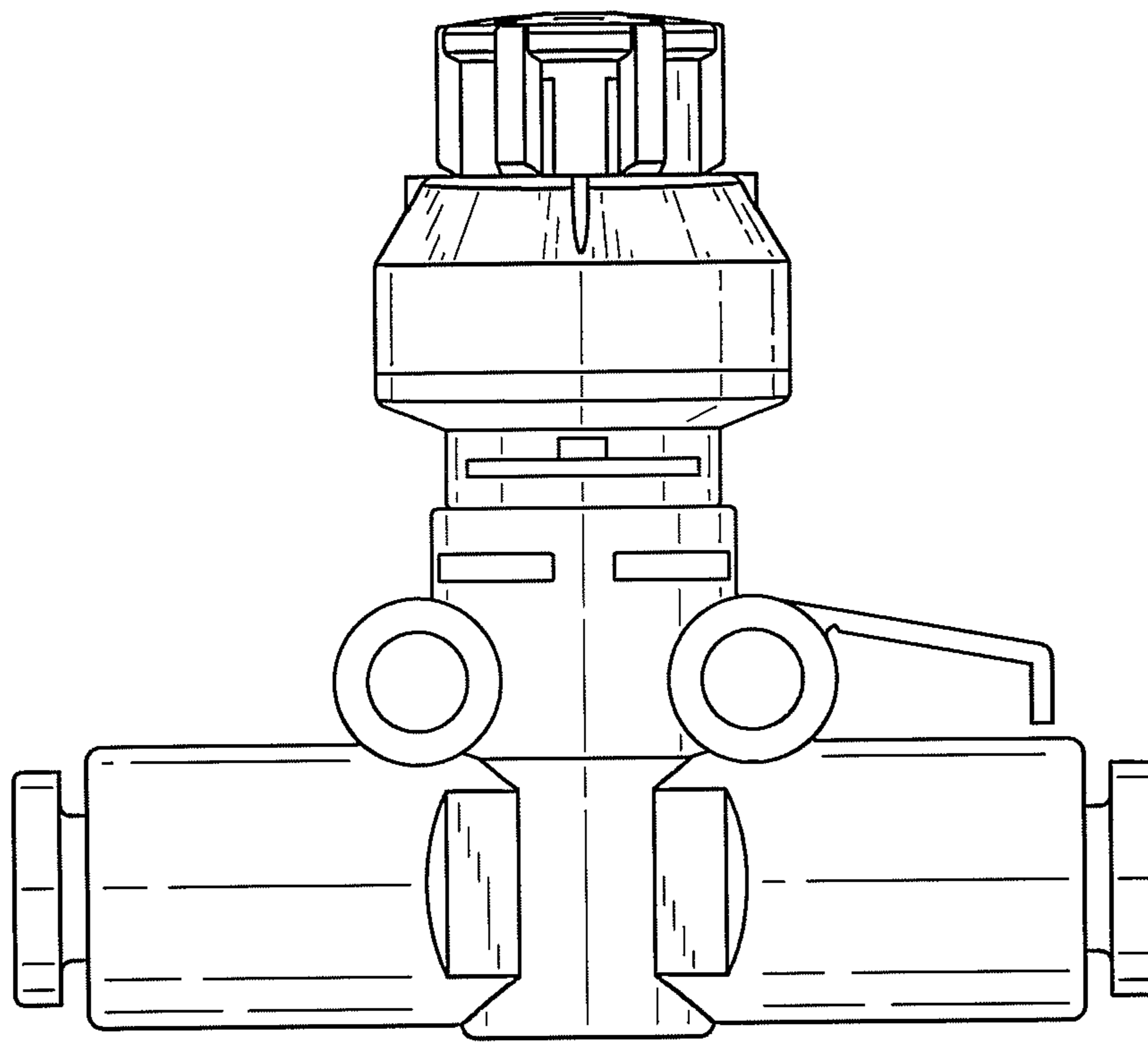

FIG. 11

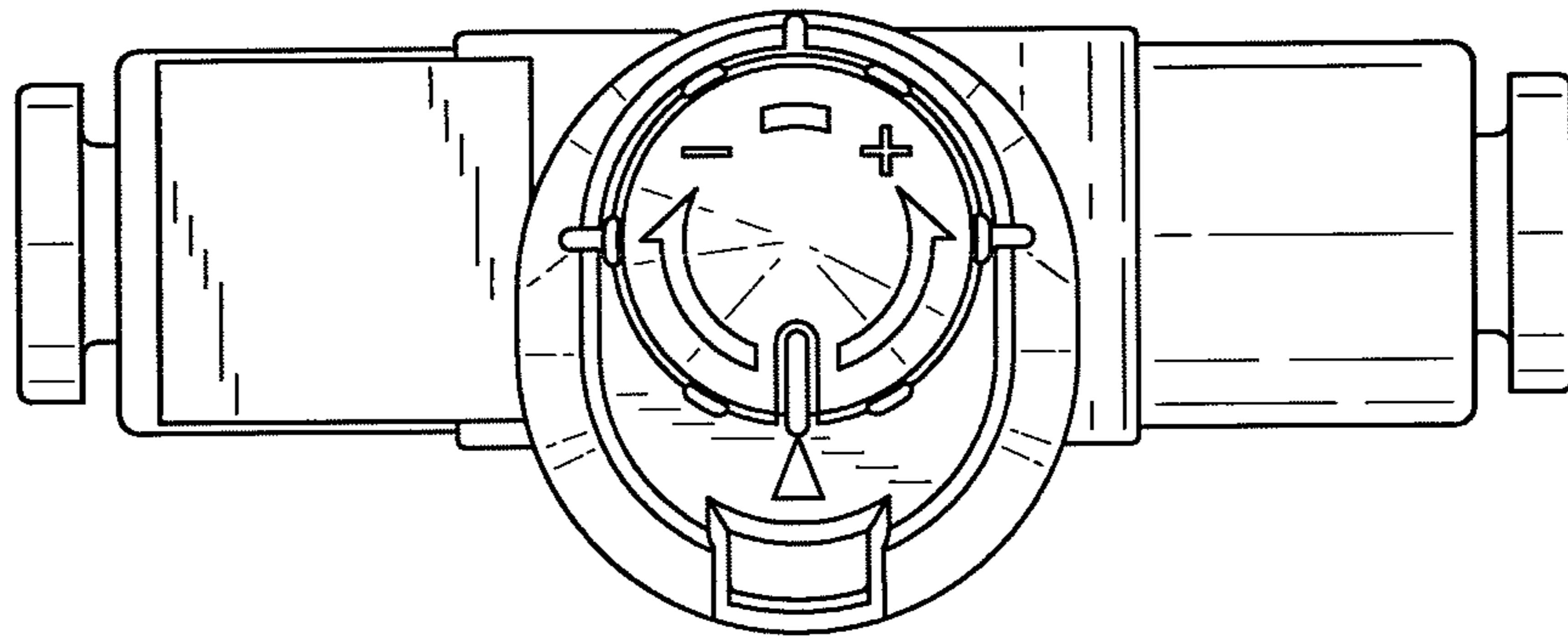

FIG. 12

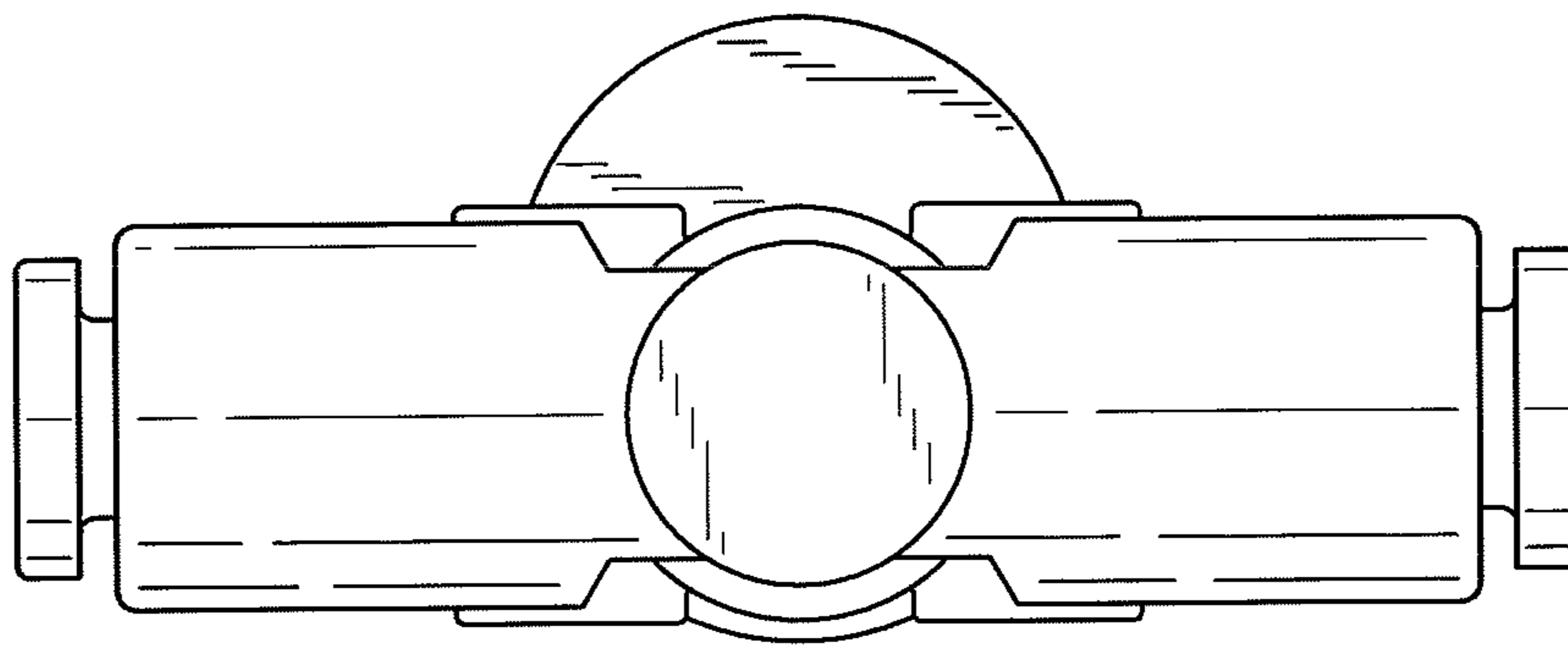

FIG. 13

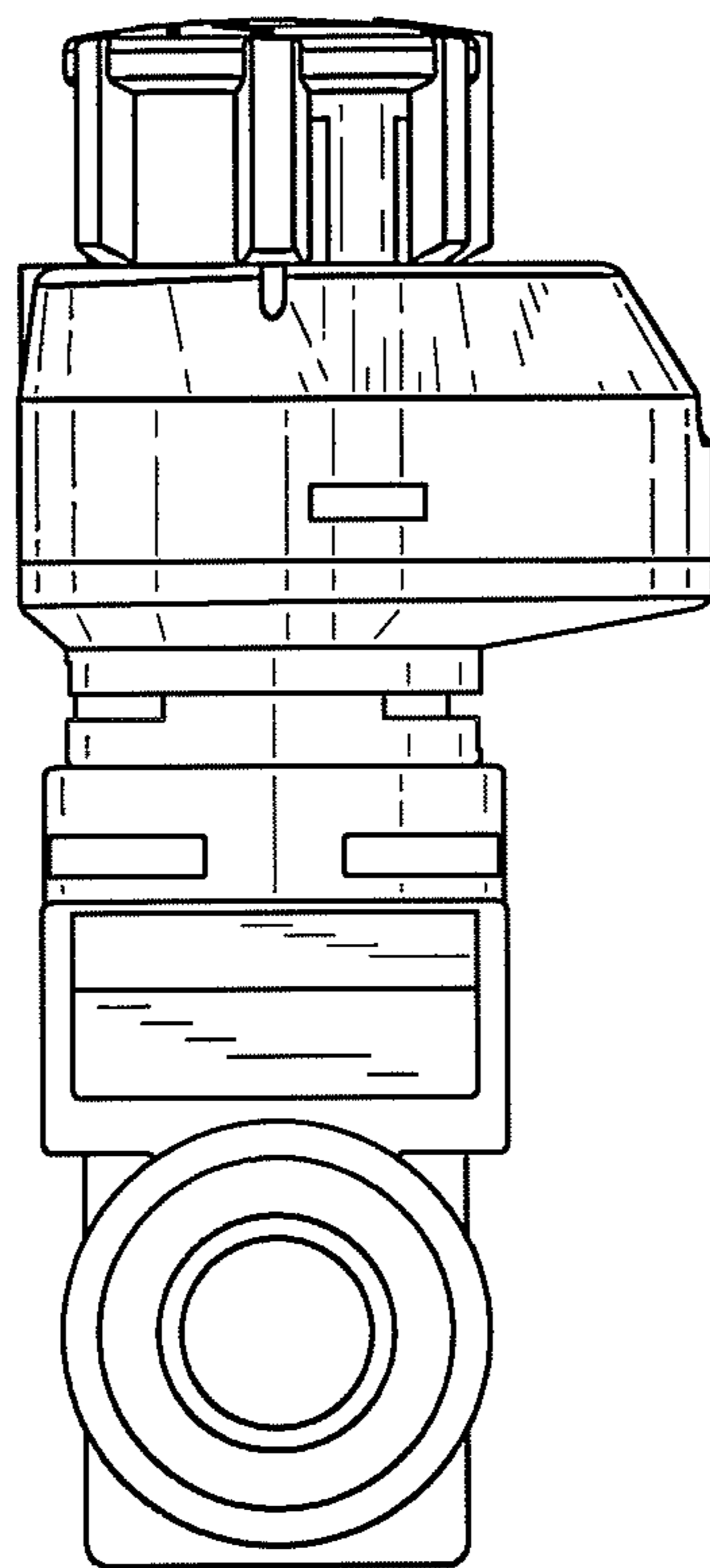

FIG. 14

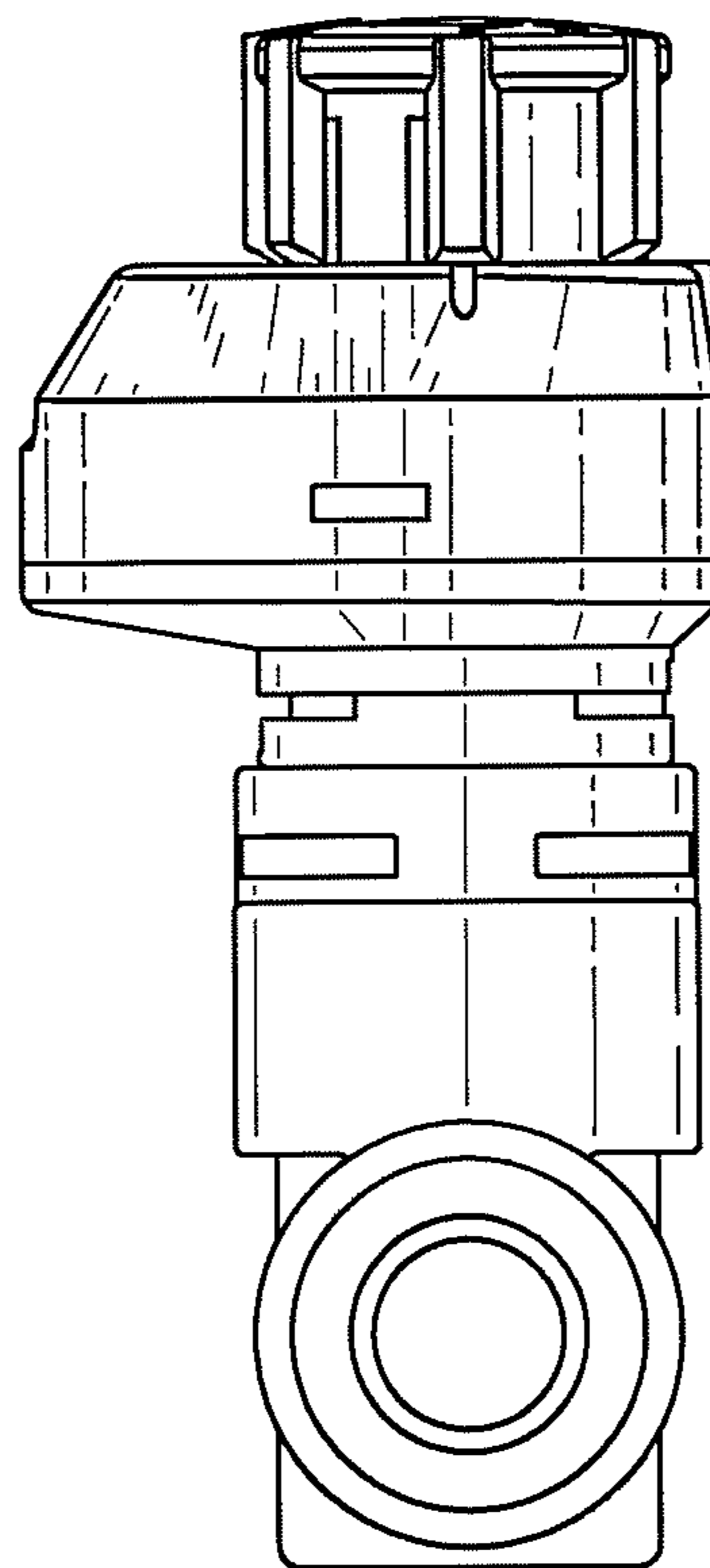

FIG. 15

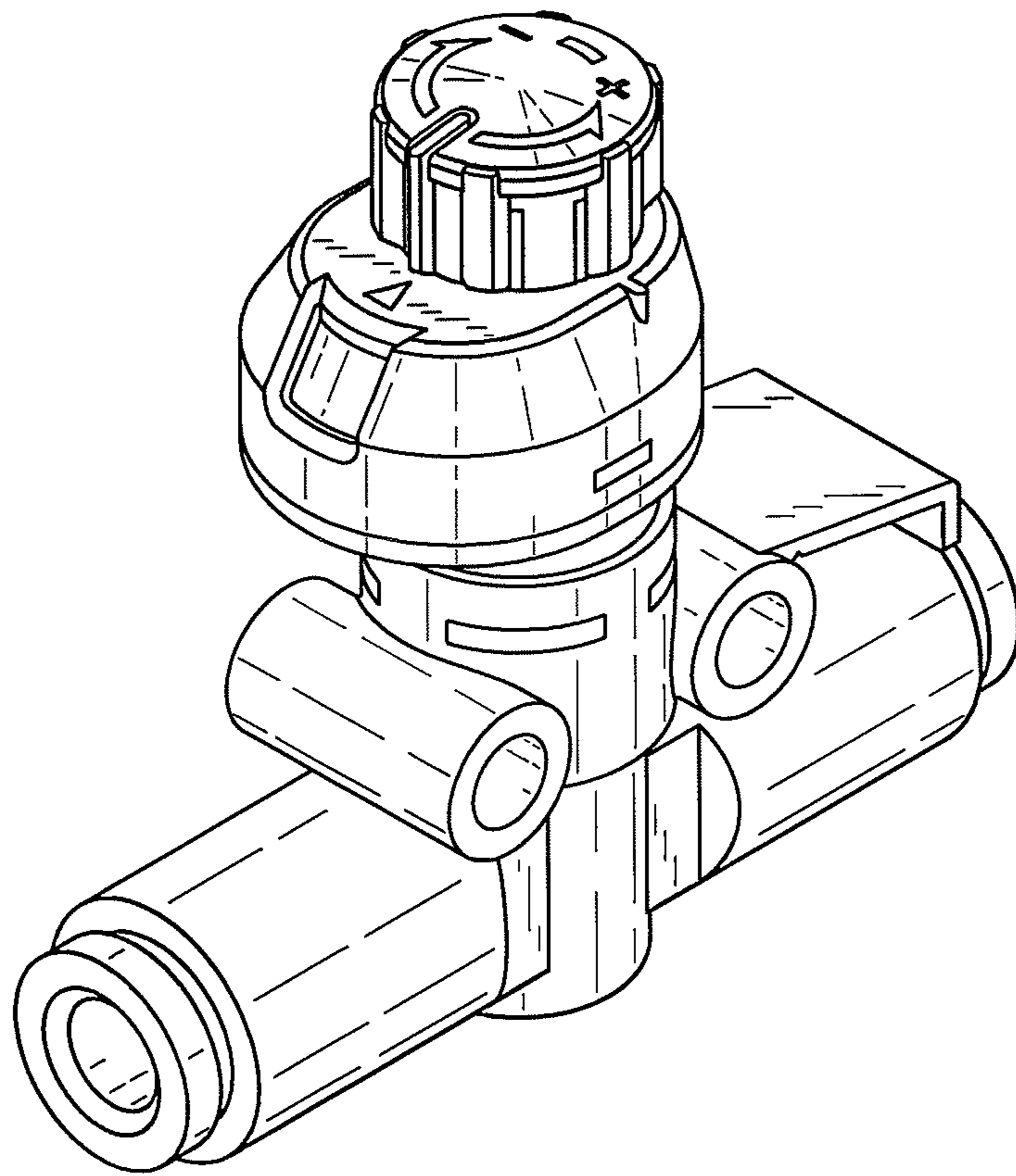

FIG. 16

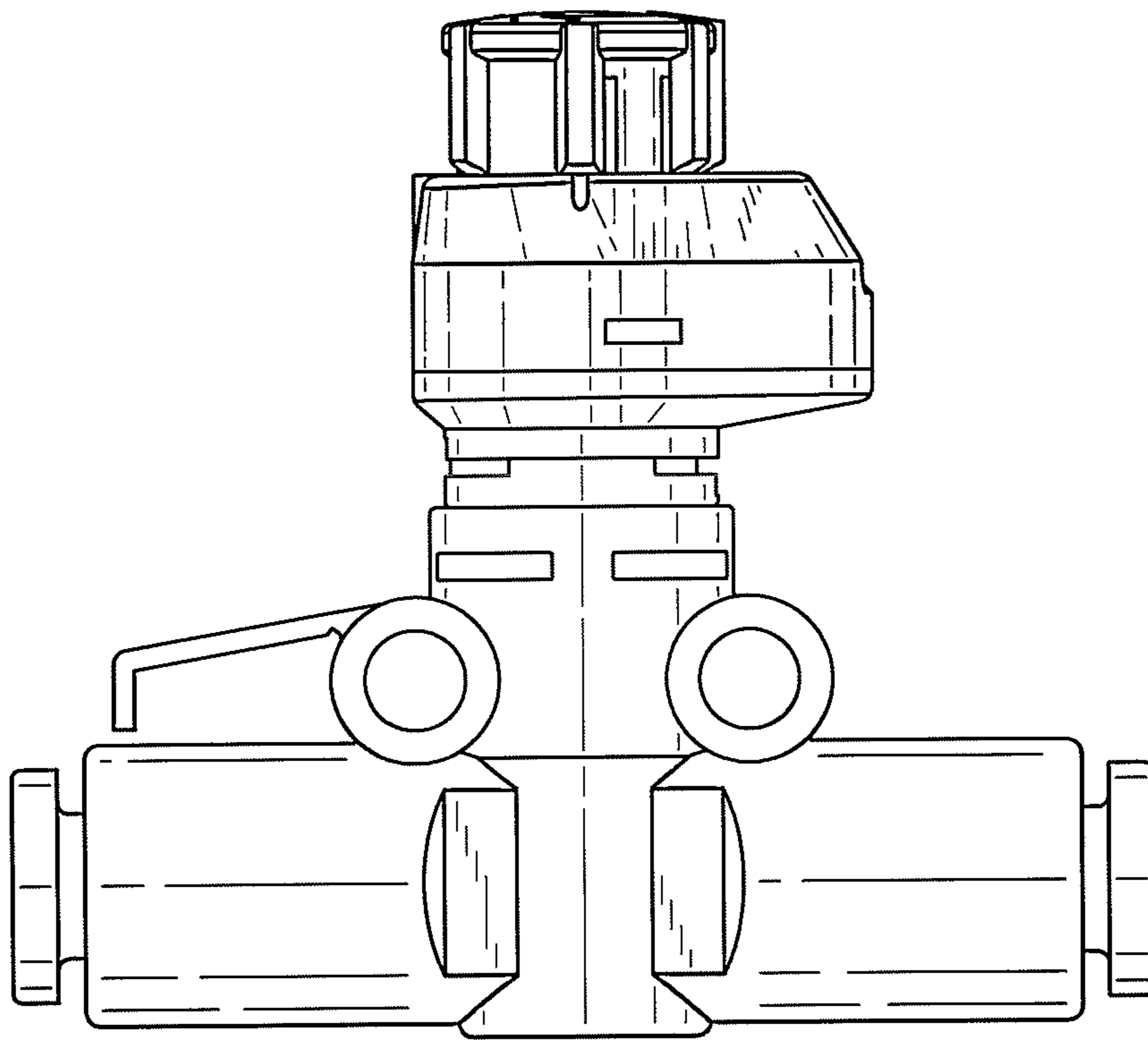

FIG. 17

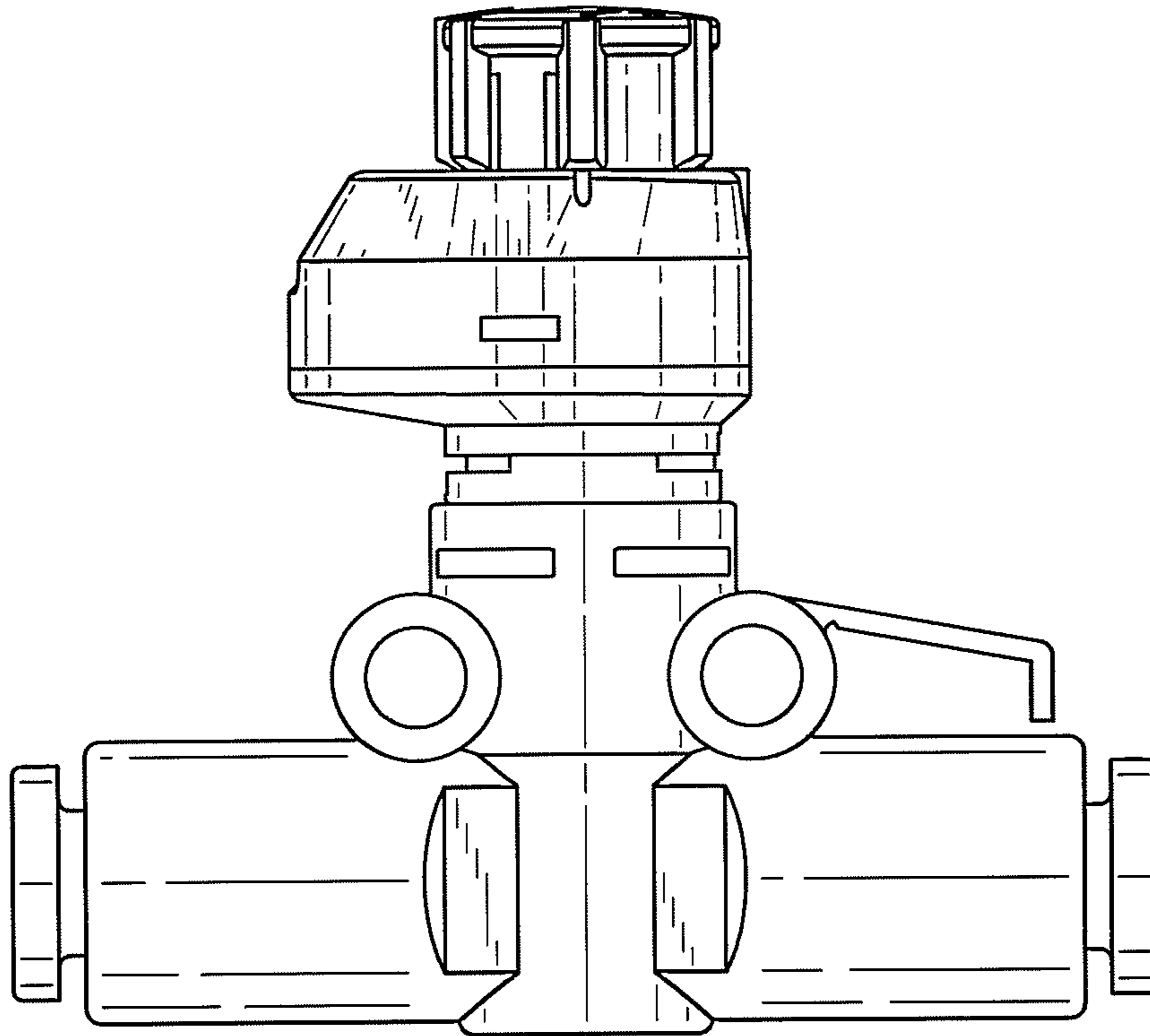

FIG. 18

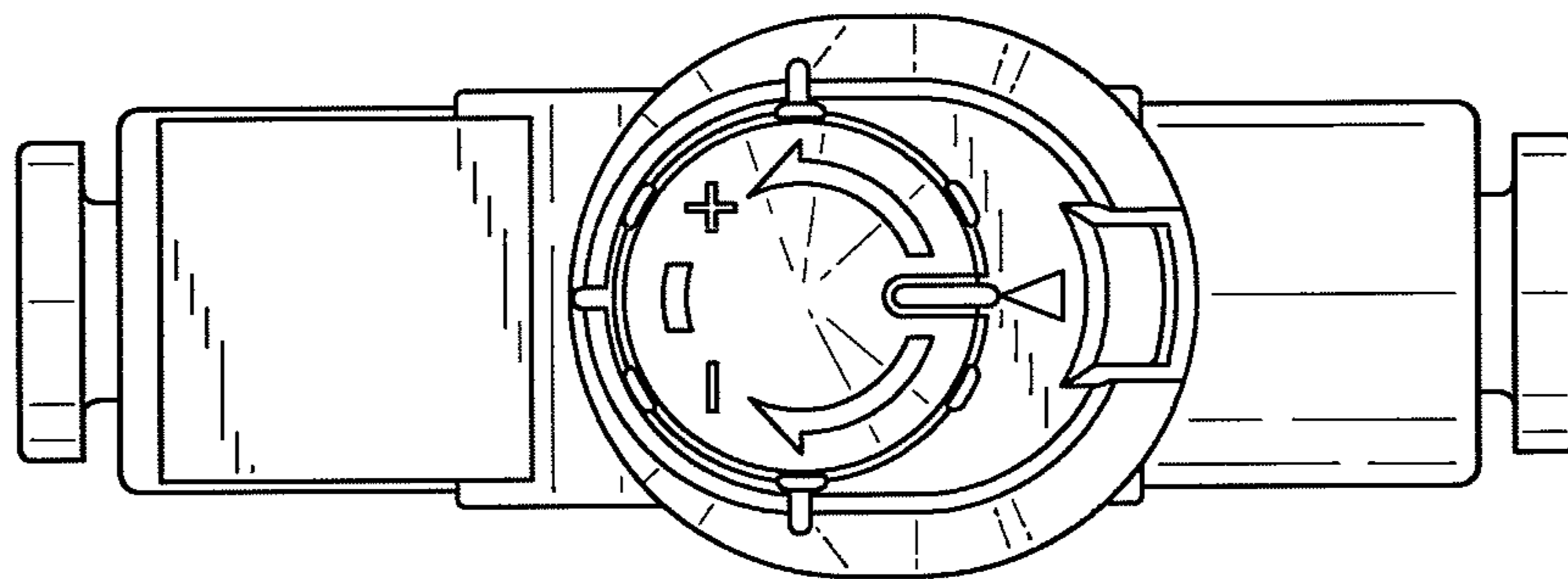

FIG. 19

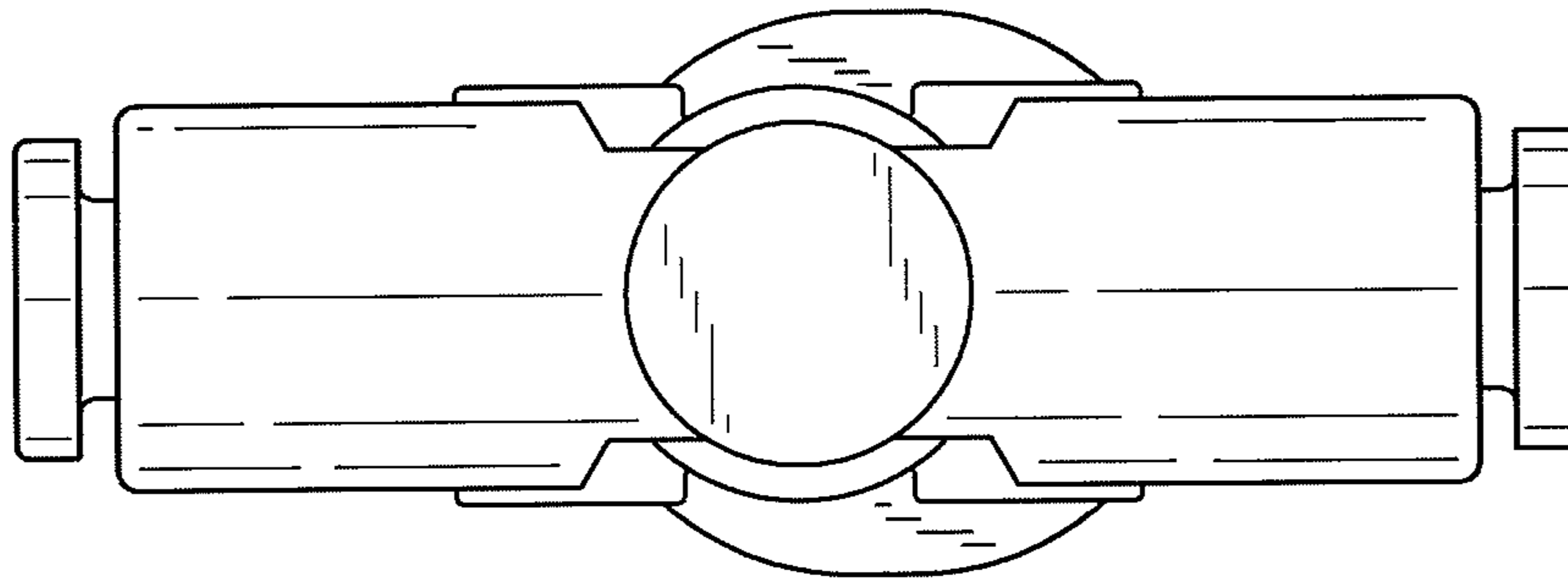

FIG. 20

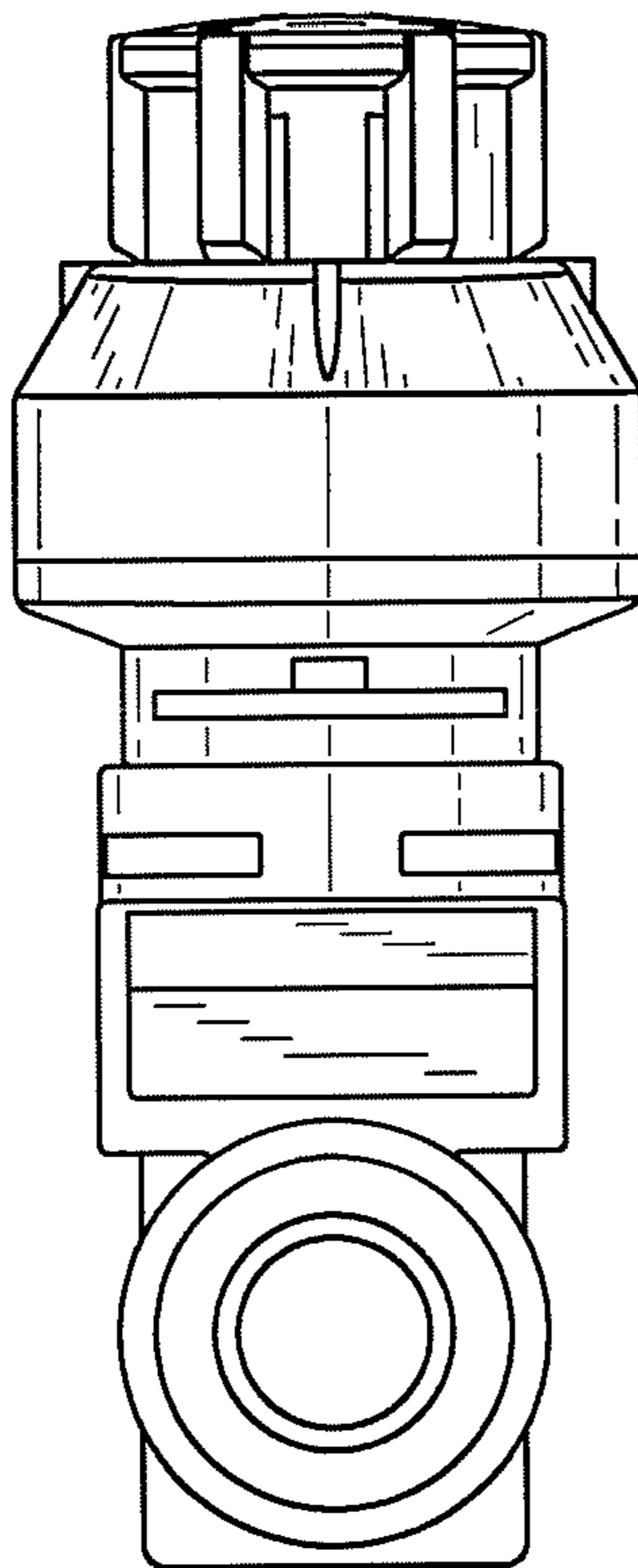

FIG. 21

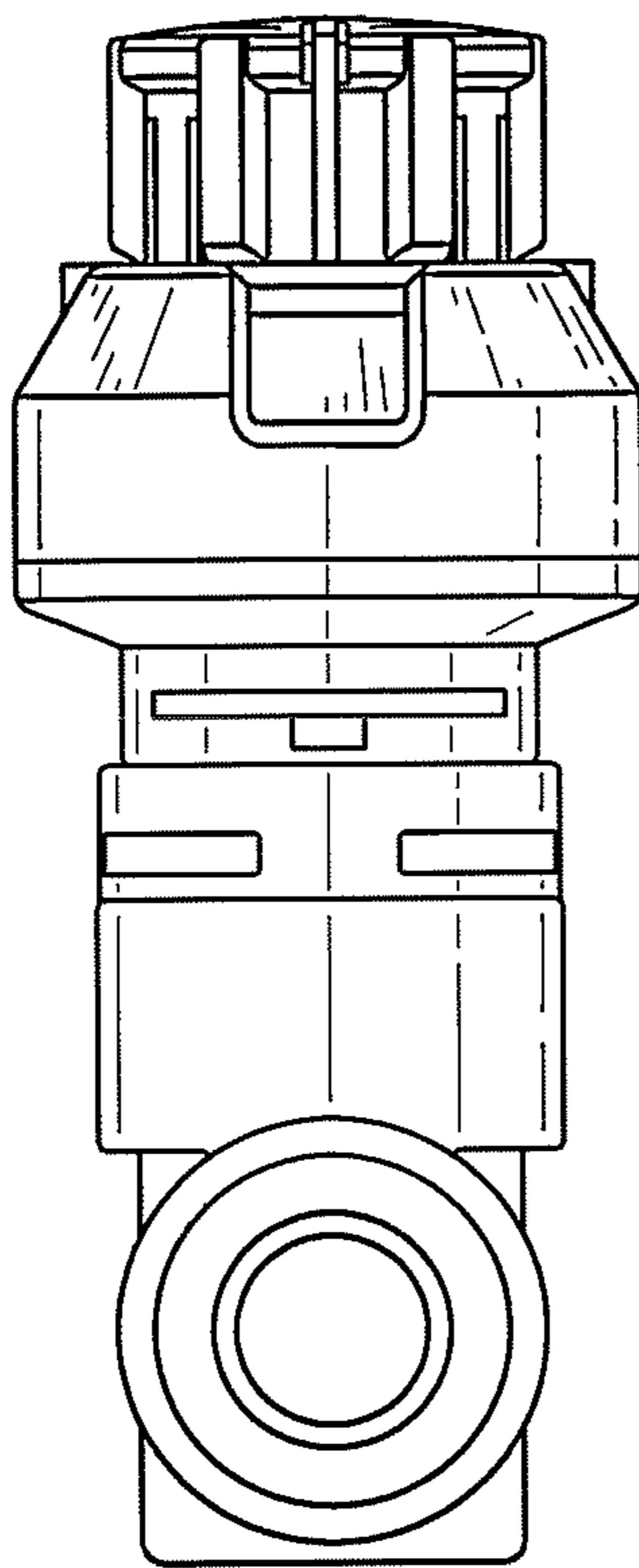

FIG. 22

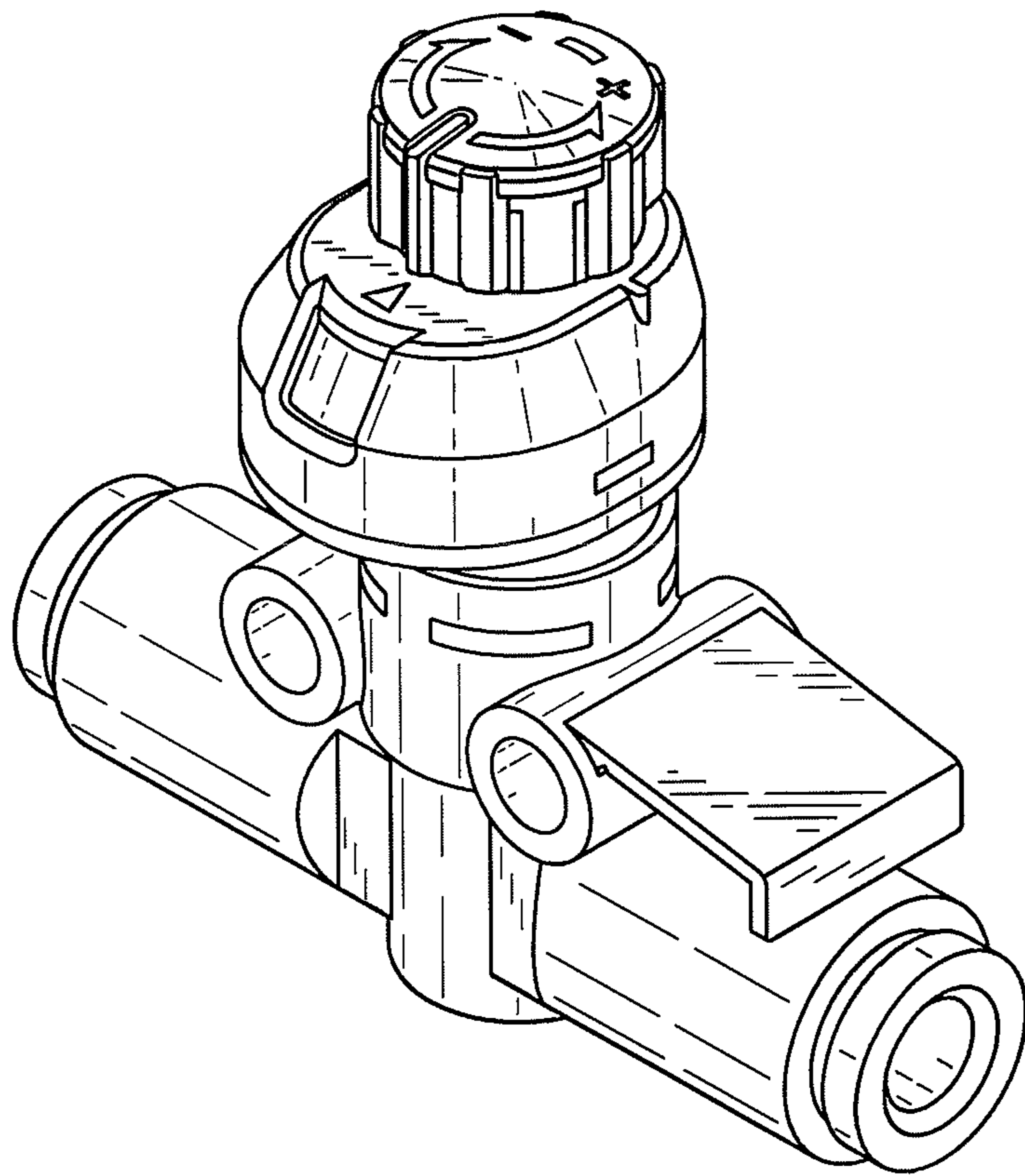

FIG. 23

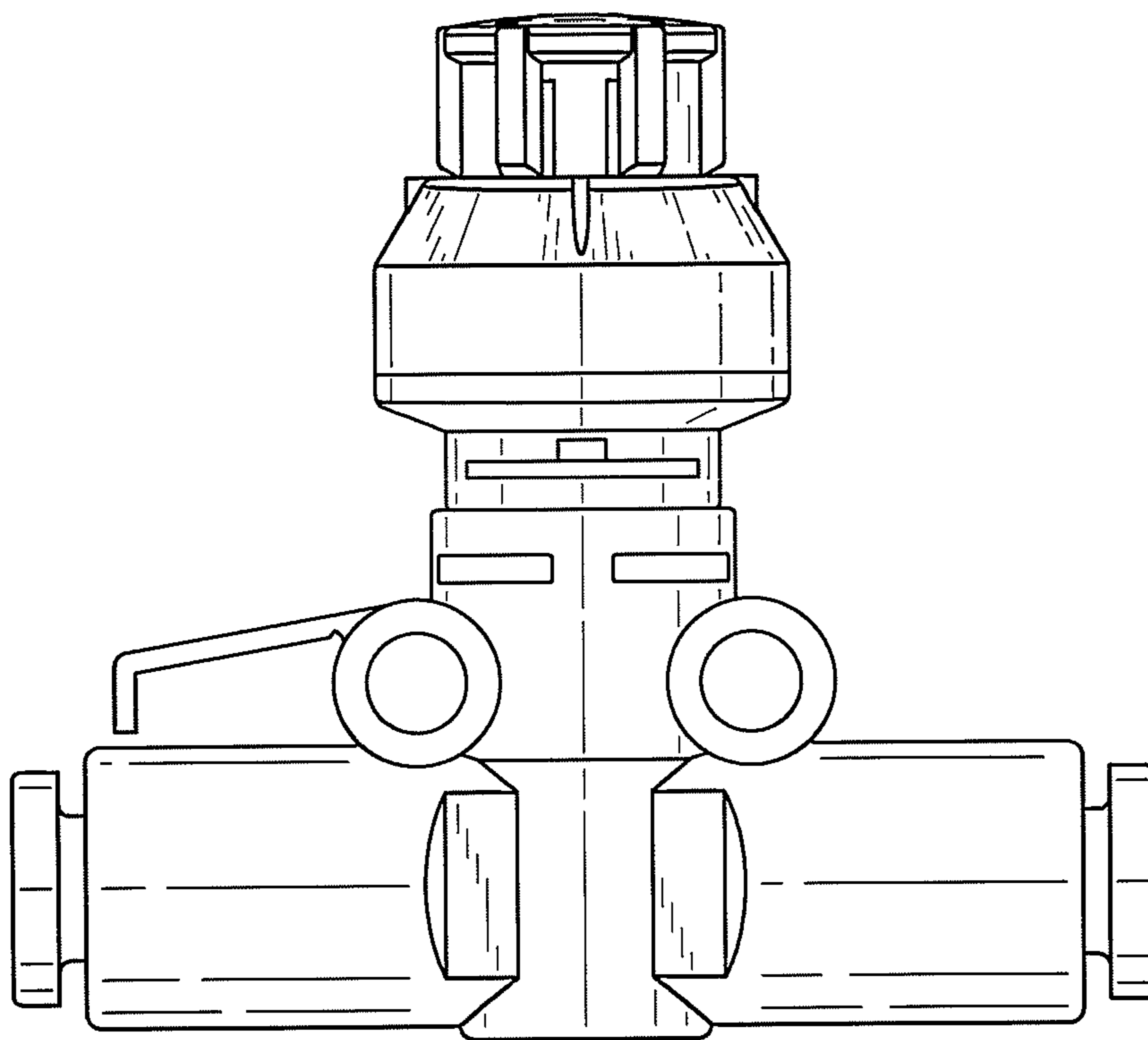

FIG. 24

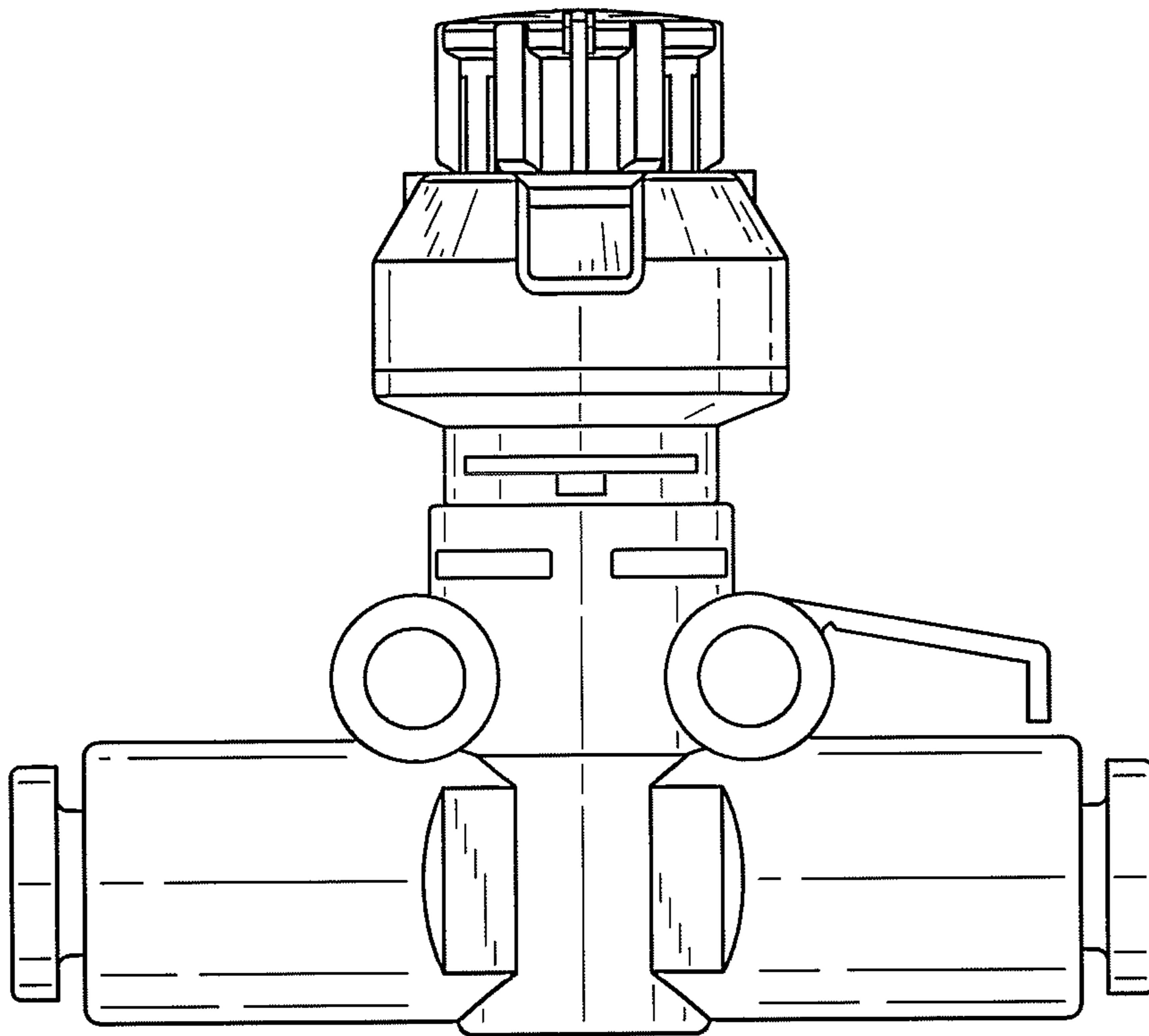

FIG. 25

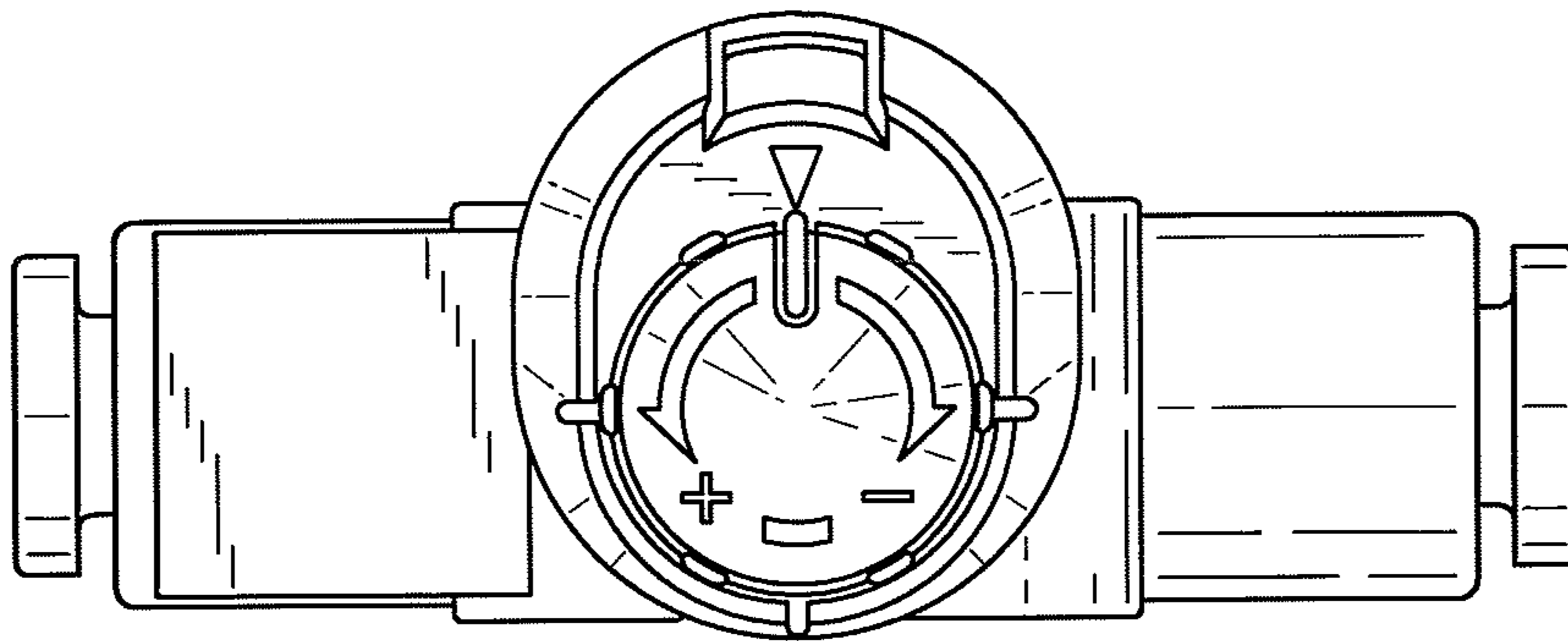

FIG. 26

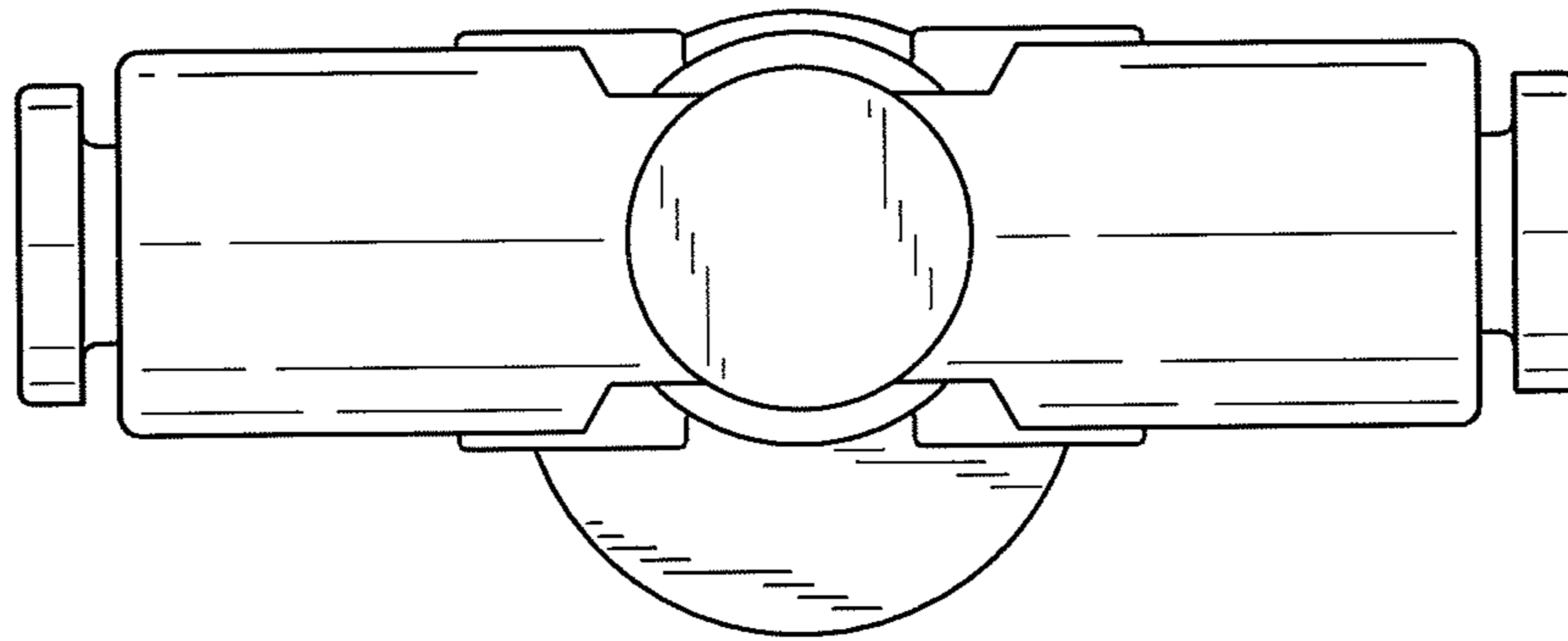

FIG. 27

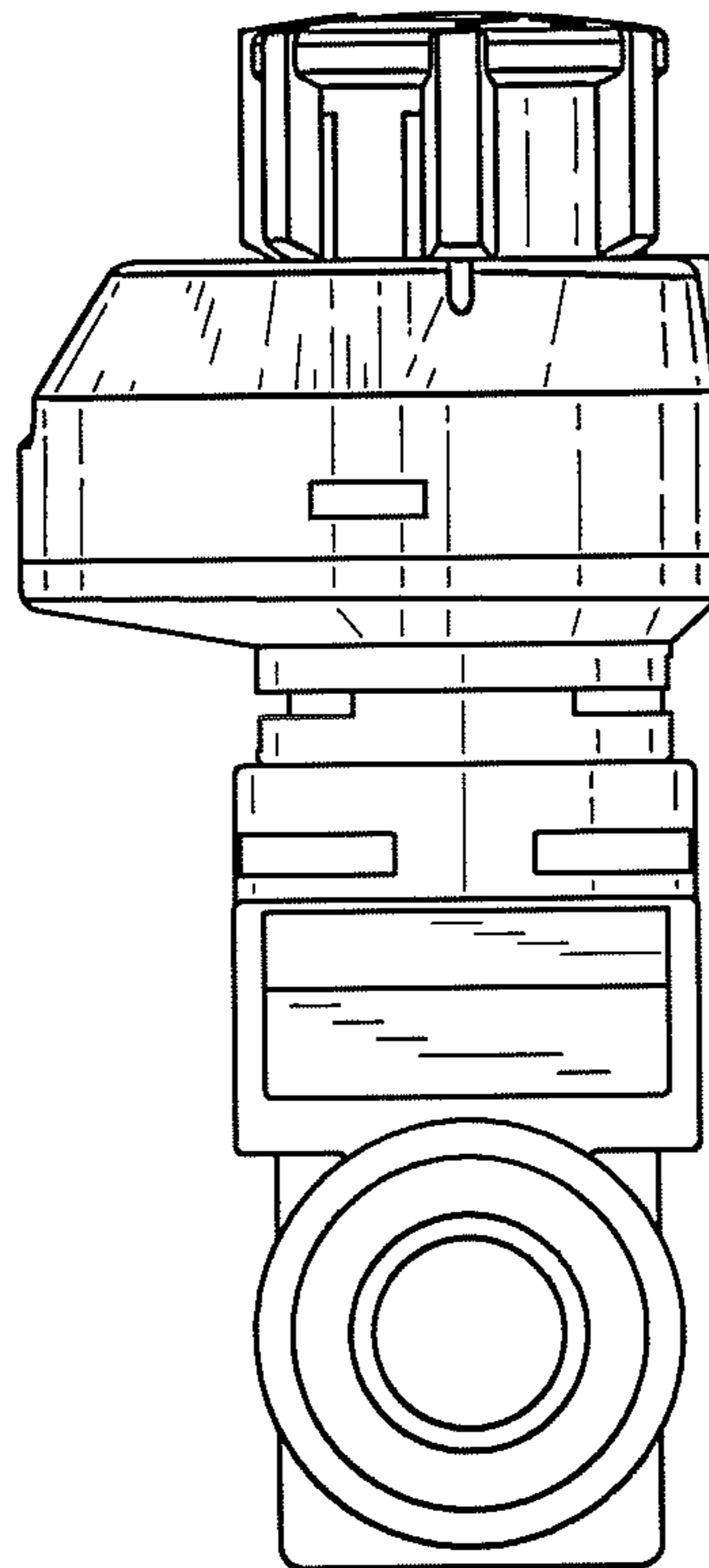

FIG. 28

