



US00D736680S

(12) **United States Design Patent**
Nishimoto et al.

(10) **Patent No.:** **US D736,680 S**
(45) **Date of Patent:** **** Aug. 18, 2015**

(54) **REAR COWL FOR MOTORCYCLE**

(71) Applicant: **HONDA MOTOR CO., LTD.**, Tokyo
(JP)

(72) Inventors: **Taro Nishimoto**, Wako (JP); **Hirota Mizunoya**, Wako (JP)

(73) Assignee: **HONDA MOTOR CO., LTD.**, Tokyo
(JP)

(**) Term: **14 Years**

(21) Appl. No.: **29/495,668**

(22) Filed: **Jul. 2, 2014**

(30) **Foreign Application Priority Data**

Jan. 8, 2014 (JP) 2014-000144

(51) **LOC (10) Cl.** **12-16**

(52) **U.S. Cl.**
USPC **D12/126**

(58) **Field of Classification Search**
USPC D12/182, 184, 186, 110, 114, 126;
180/219, 220, 225, 229; 296/78.1,
296/187.12, 193.01, 193.02, 193.05;
280/152.1, 304.3, 852
CPC B62D 21/157; B62D 23/00; B62D 25/02;
B62D 25/145; B62J 15/04; B62J 17/04;
B62J 27/00; B62K 11/04; B62M 7/12; F02B
61/02
See application file for complete search history.

(56) **References Cited**

U.S. PATENT DOCUMENTS

D533,125 S * 12/2006 Kokubu D12/182
D580,325 S * 11/2008 Sawabe et al. D12/182
7,552,788 B2 * 6/2009 Satake 180/68.1
D596,536 S * 7/2009 Katagiri et al. D12/126
D608,260 S * 1/2010 Toriyama et al. D12/186

D653,183 S * 1/2012 Yamazaki et al. D12/186
D683,275 S * 5/2013 Yanagita et al. D12/126
D689,800 S * 9/2013 Futamata et al. D12/126
D690,625 S * 10/2013 Futamata et al. D12/126
D695,157 S * 12/2013 Tsukui et al. D12/126
2004/0061350 A1 * 4/2004 Yoshida et al. 296/78.1

(Continued)

FOREIGN PATENT DOCUMENTS

JP 2006213107 A * 8/2006 B62J 17/00
JP 201217152 A * 9/2012 B62J 17/00

(Continued)

Primary Examiner — Philip S Hyder

Assistant Examiner — Darlington Ly

(74) *Attorney, Agent, or Firm* — Birch, Stewart, Kolasch & Birch, LLP

(57) **CLAIM**

The ornamental design for a rear cowl for motorcycle, as shown and described.

DESCRIPTION

FIG. 1 is a perspective view from the front side of a rear cowl for motorcycle.
FIG. 2 is a perspective view from the rear side thereof.
FIG. 3 is a perspective view from the front side thereof.
FIG. 4 is a perspective view from the rear side thereof.
FIG. 5 is a front elevation view thereof.
FIG. 6 is a rear elevation view thereof.
FIG. 7 is a top plan view thereof.
FIG. 8 is a bottom plan view thereof.
FIG. 9 is a right side elevation view thereof.
FIG. 10 is a left side elevation view thereof; and,
FIG. 11 is a referential view showing use thereof.
The broken line showing of a motorcycle in FIG. 11 and portions of the rear cowl in FIGS. 1-10 are for the purposes of illustrating environmental structure and portions of the article of manufacture that forms no part of the claimed design.

1 Claim, 11 Drawing Sheets

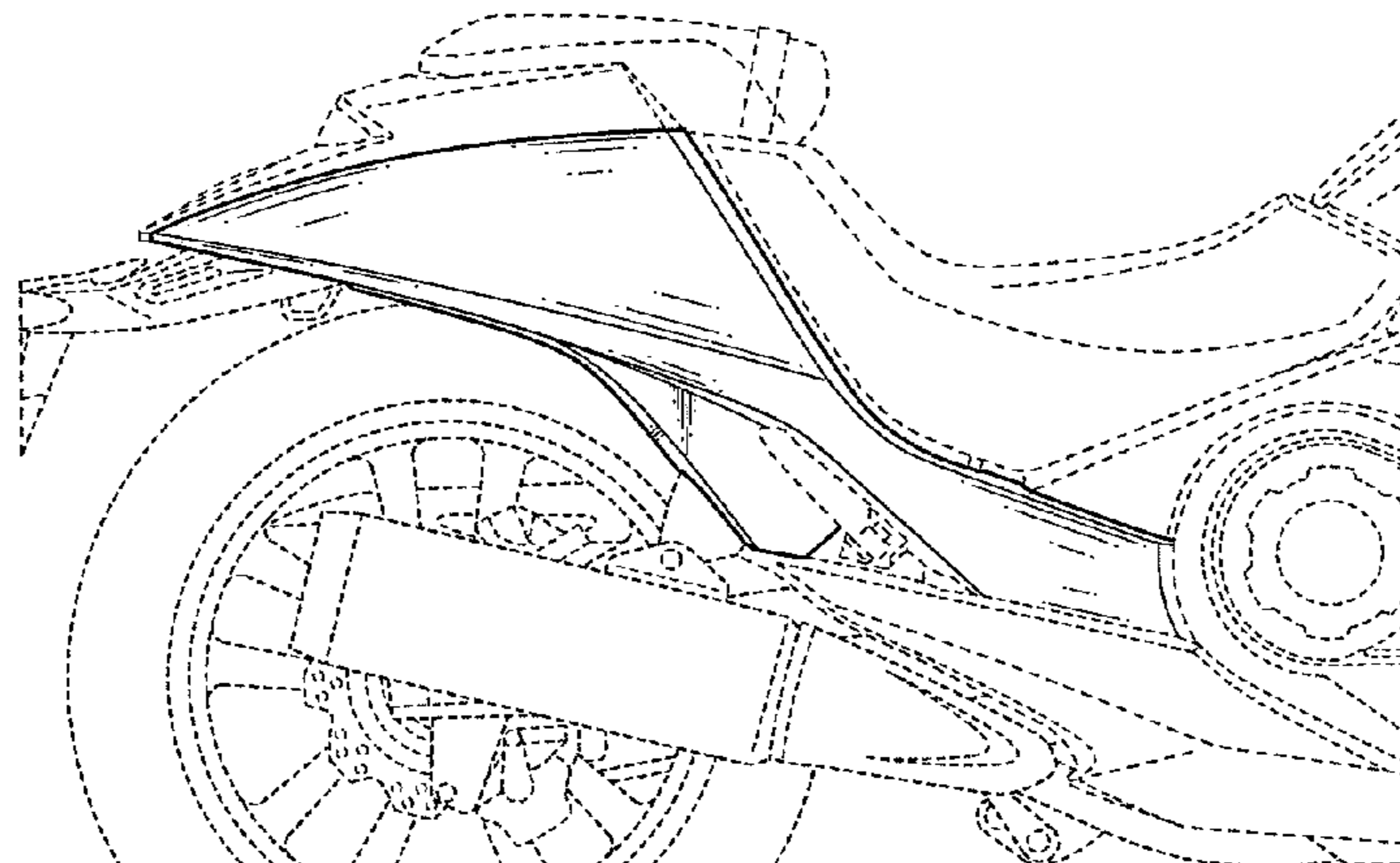

(56)

References Cited

FOREIGN PATENT DOCUMENTS

U.S. PATENT DOCUMENTS

2010/0181133 A1* 7/2010 Mitomi et al. 180/229
2014/0084623 A1* 3/2014 Miyamoto et al. 296/180.1

JP 2012183955 A * 9/2012 B62J 17/00
JP 2013052831 A * 3/2013 B62J 17/00

* cited by examiner

FIG. 1

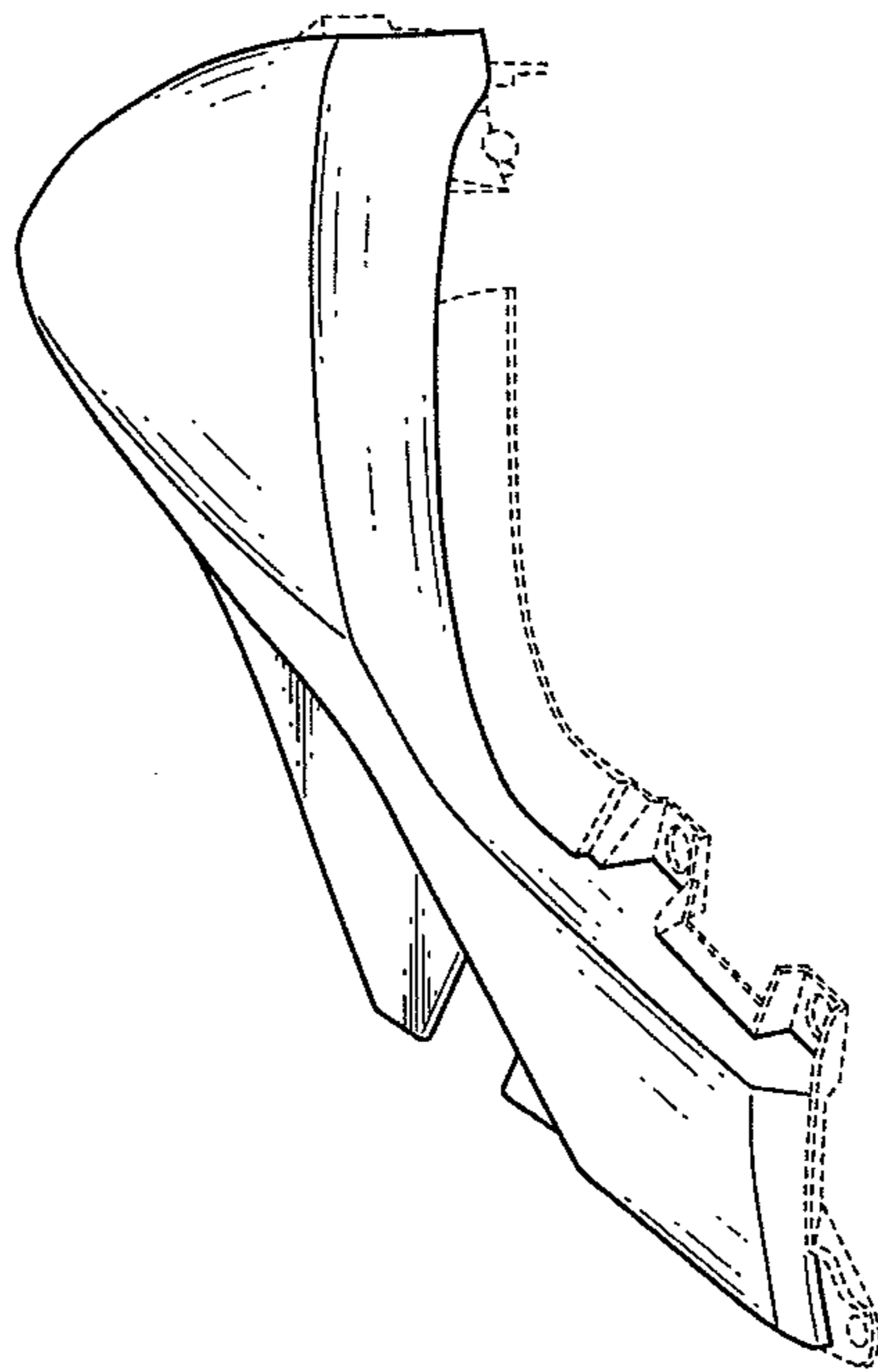

FIG. 2

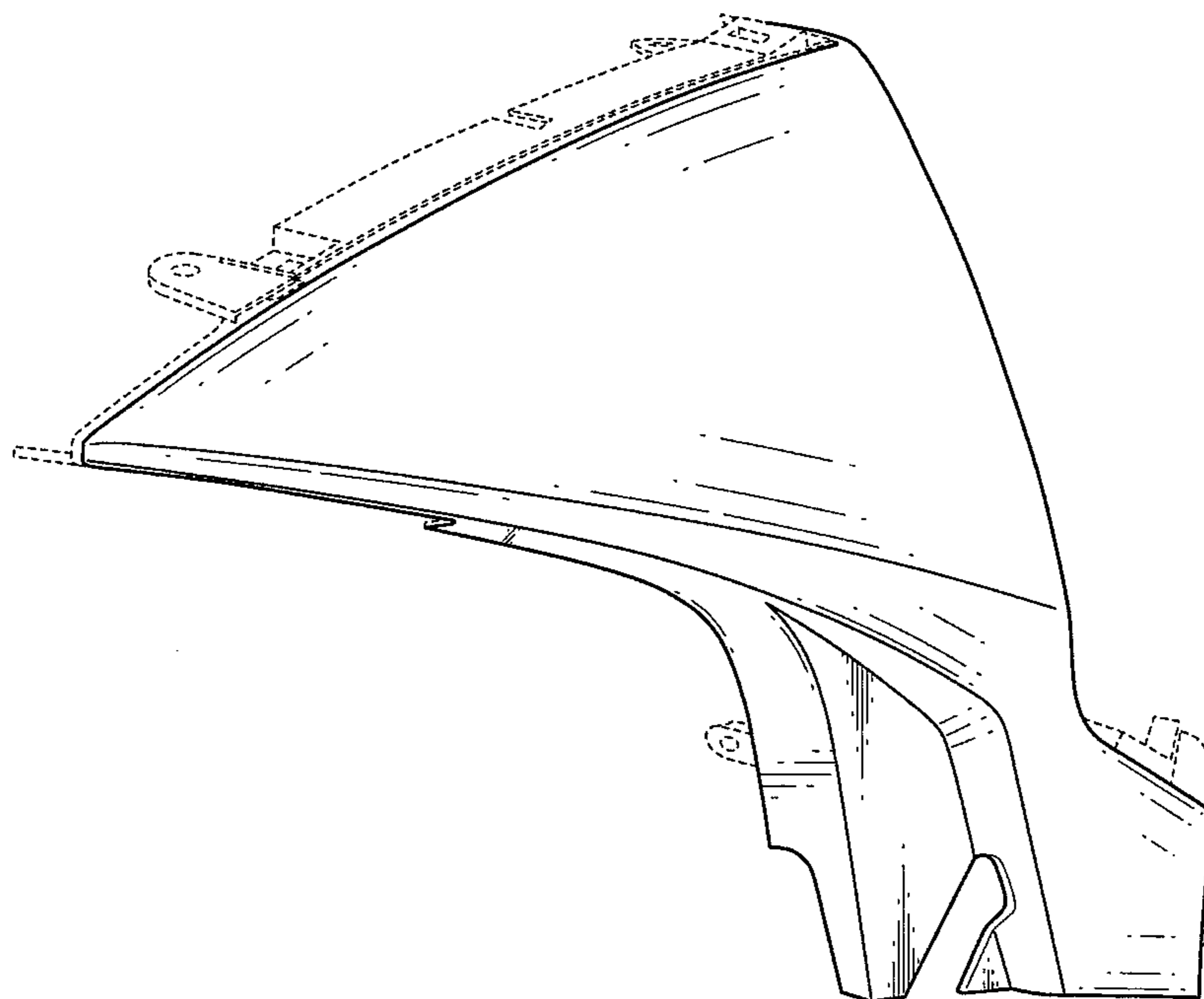

FIG. 3

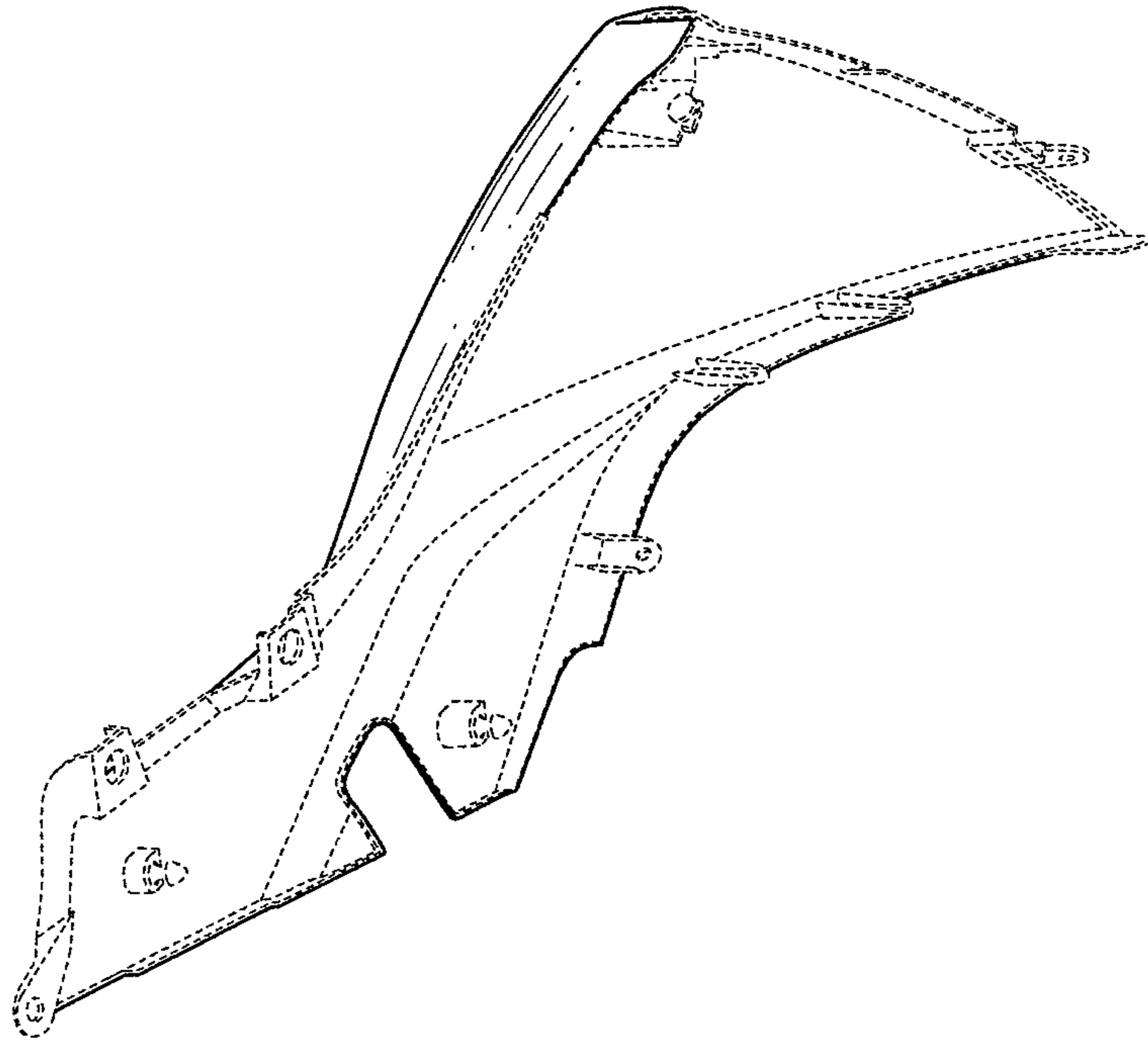

FIG. 4

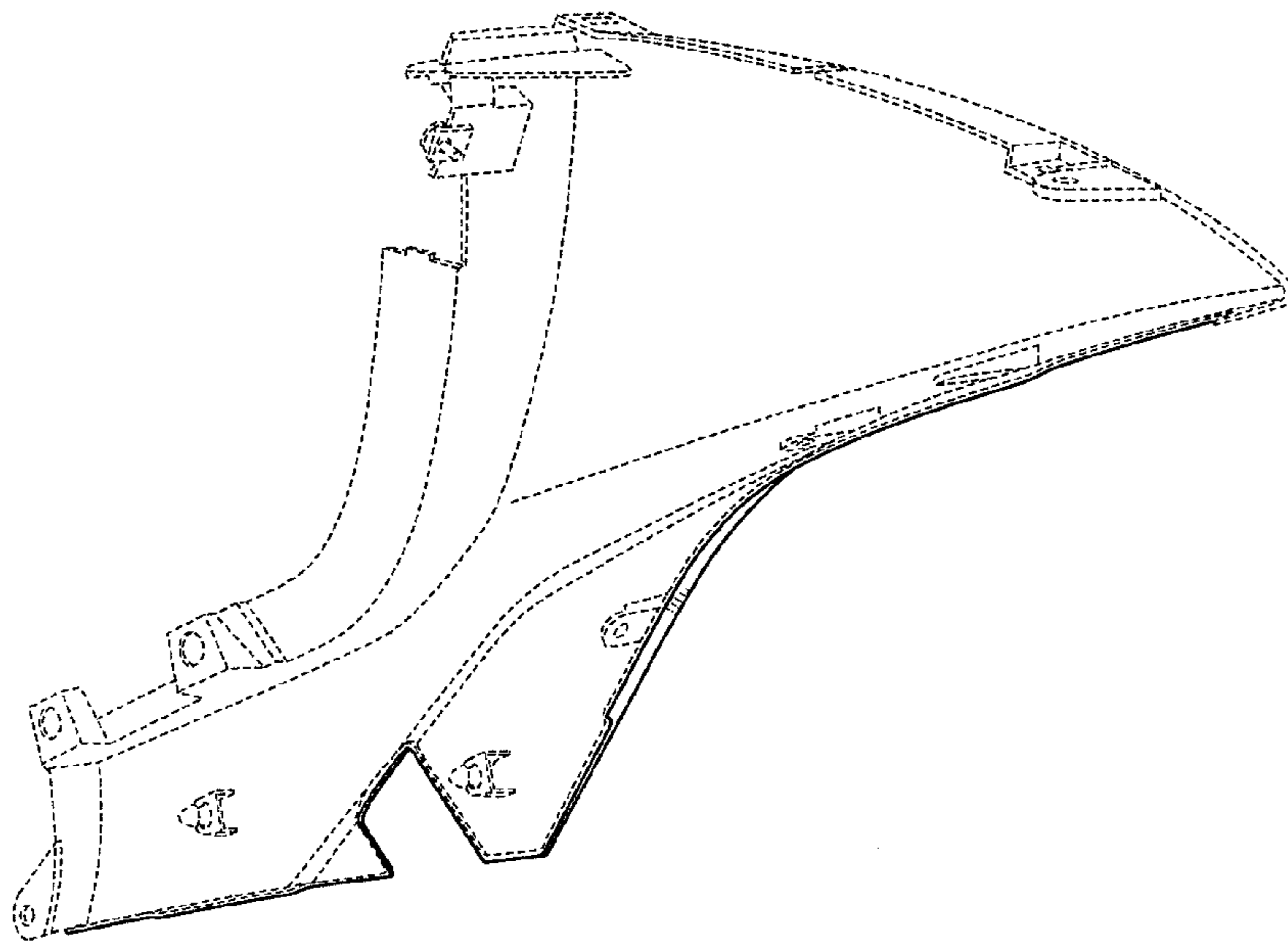

FIG. 5

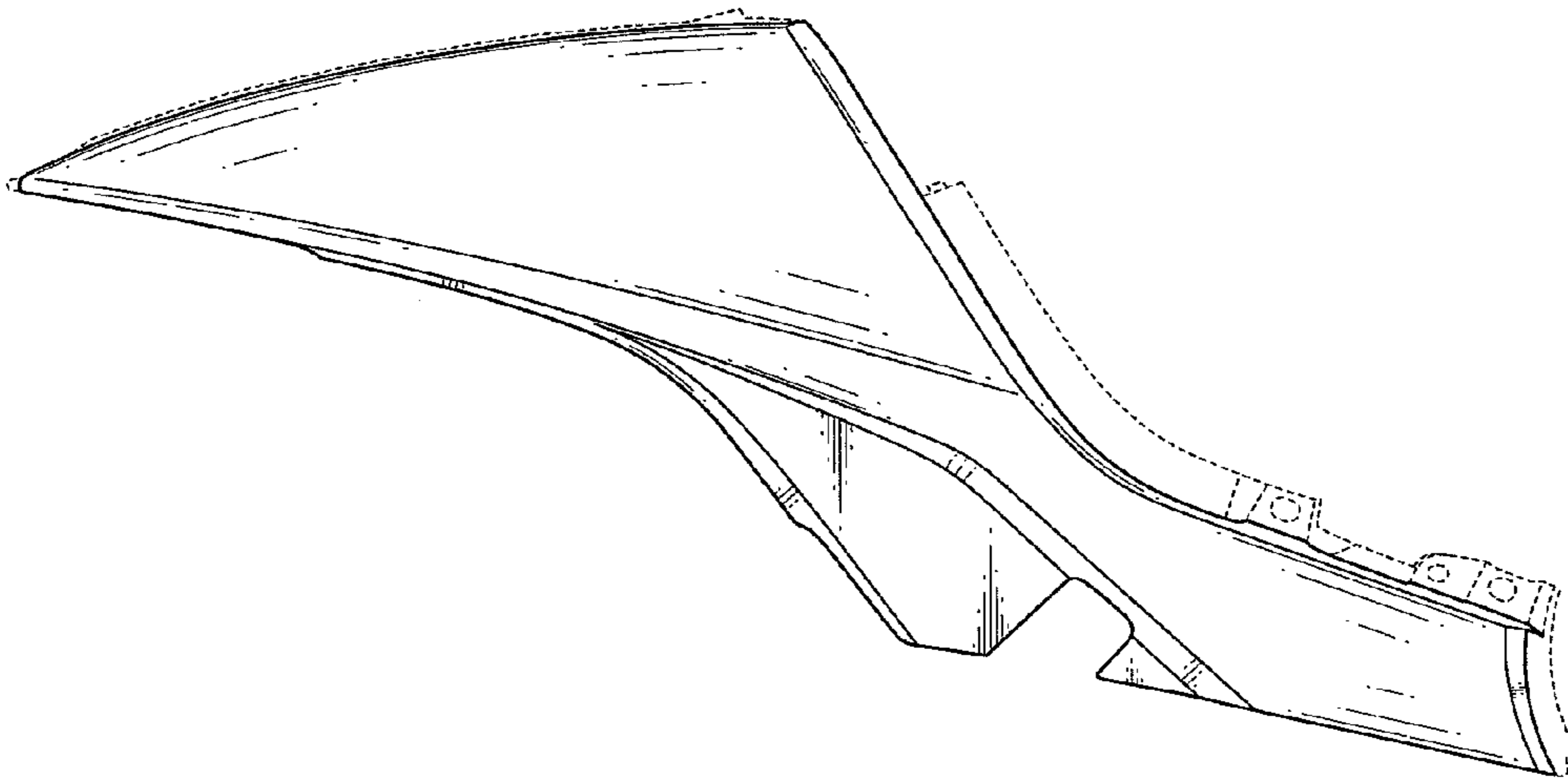

FIG. 6

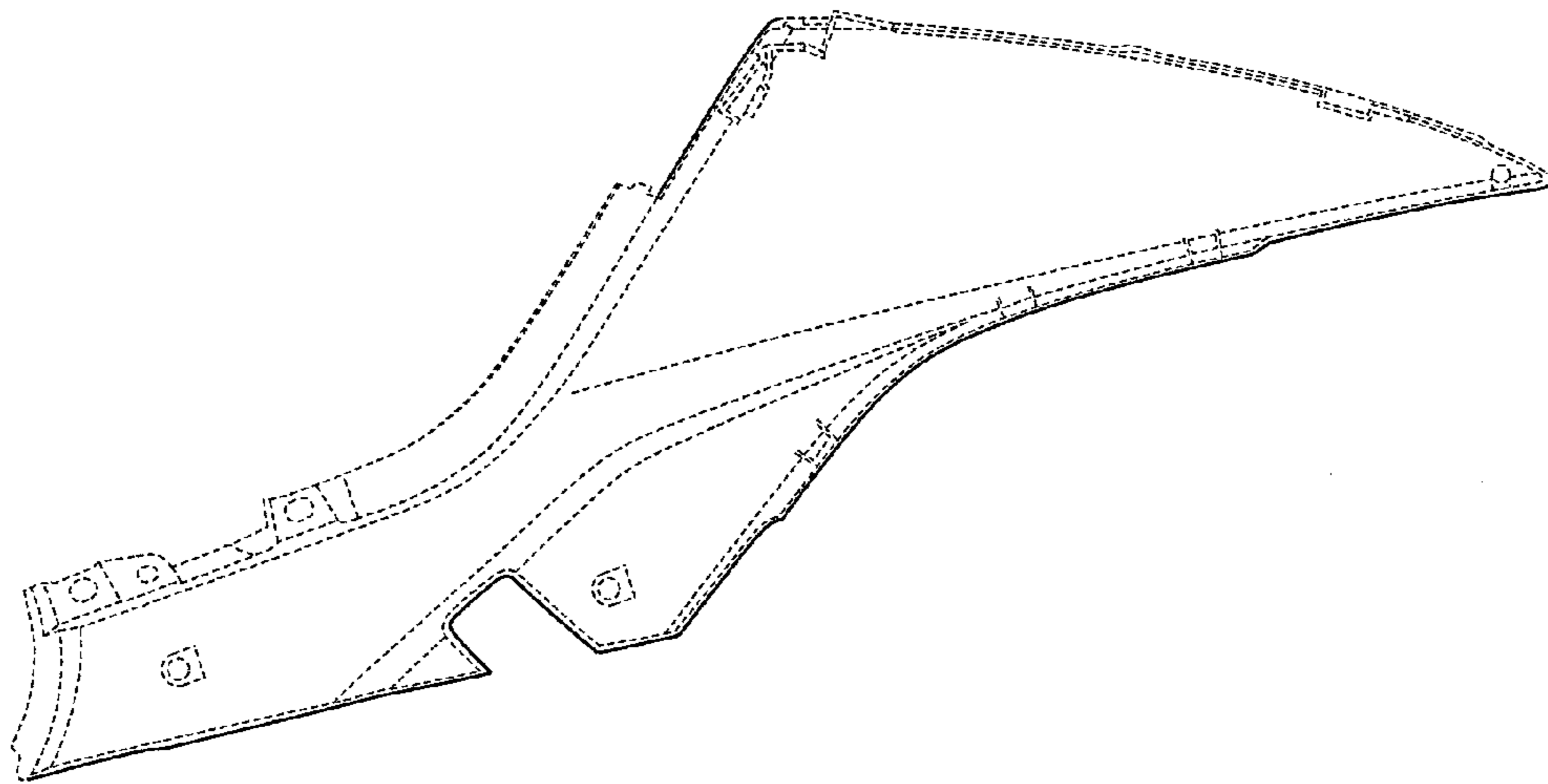

FIG. 7

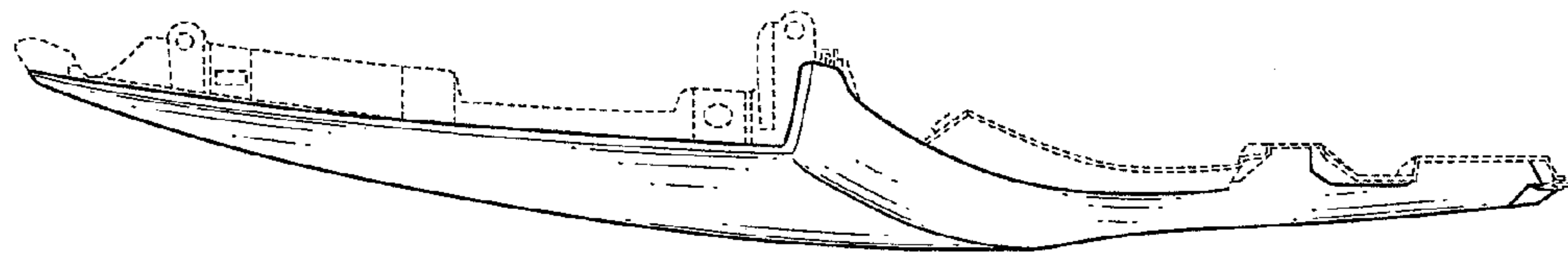

FIG. 8

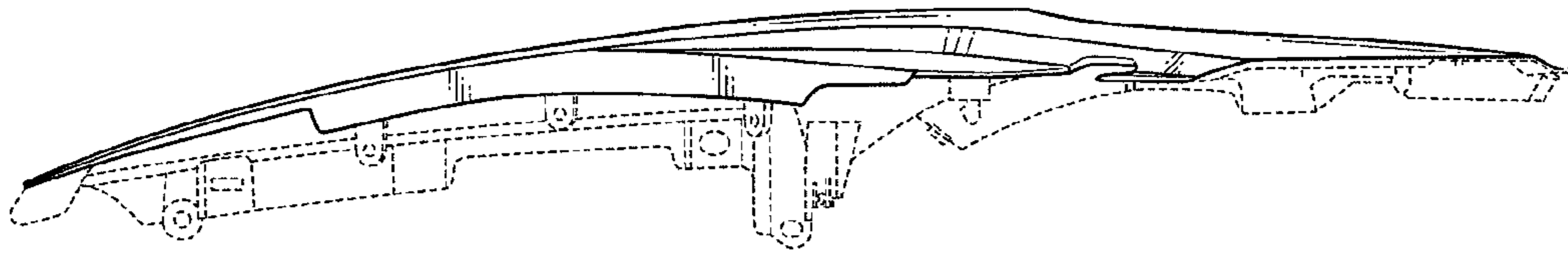

FIG. 9

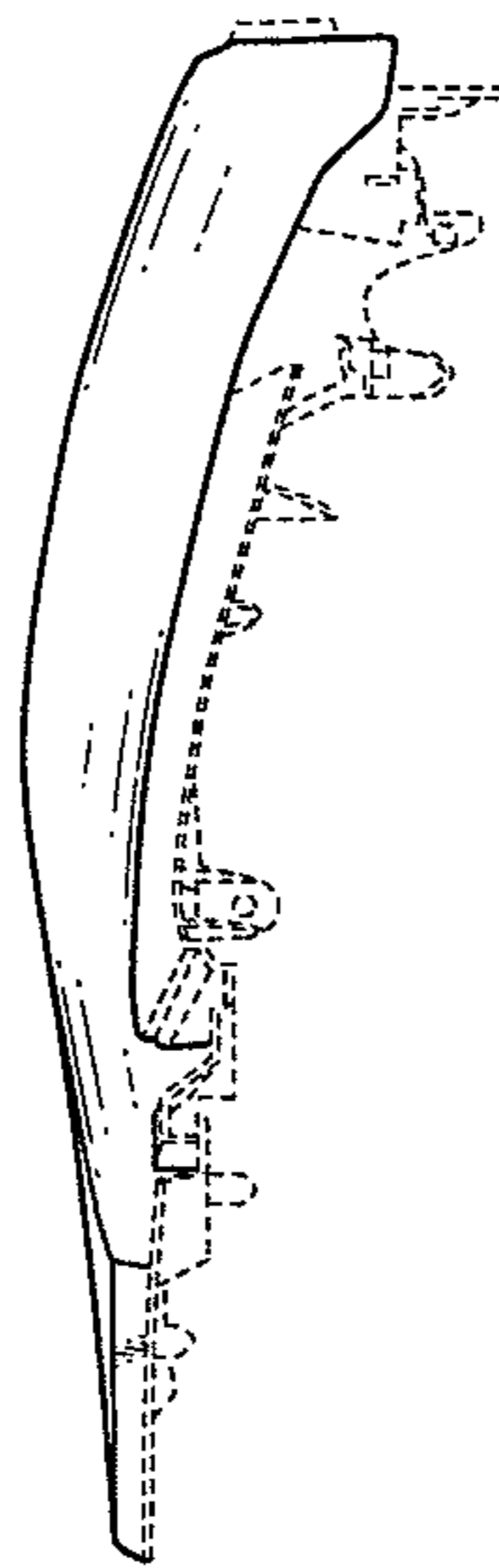

FIG. 10

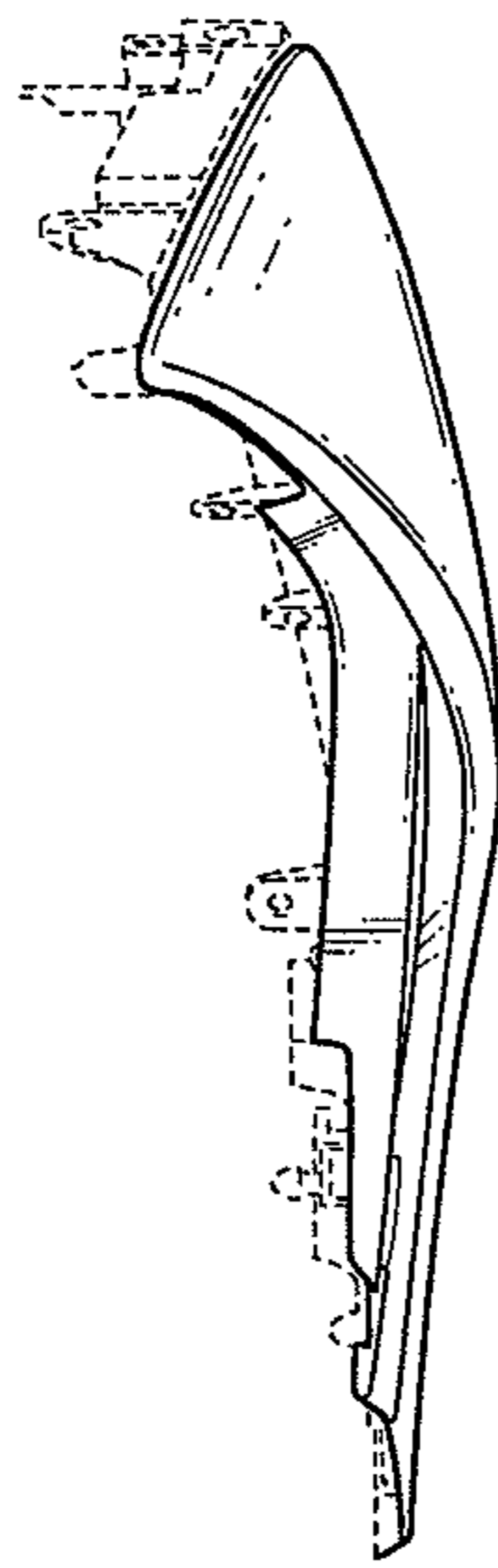

FIG. 11

