



US00D736593S

(12) **United States Design Patent**  
**Ade**

(10) **Patent No.:** **US D736,593 S**

(45) **Date of Patent:** **\*\* Aug. 18, 2015**

- (54) **ADJUSTABLE CHAIN LATCH**
- (71) Applicant: **SAFE DOC, L.L.C.**, Overland Park, KS  
(US)
- (72) Inventor: **Jimmy Ray Ade**, Overland Park, KS  
(US)
- (73) Assignee: **SAFE DOC, L.L.C.**, Overland Park, KS  
(US)

3,661,360	A	5/1972	Windham	
3,999,408	A *	12/1976	Kawakami	70/18
4,017,104	A	4/1977	Walker	
D246,760	S *	12/1977	Hart	D8/341
4,105,221	A	8/1978	Fleming	
4,302,955	A *	12/1981	Kawakami	70/30
D274,125	S *	6/1984	Hardesty et al.	D8/341
4,617,703	A	10/1986	Schaeffer	
D469,332	S *	1/2003	Meekma et al.	D8/333
6,619,708	B1	9/2003	Naylor	
6,866,120	B1 *	3/2005	Butterworth	182/187
D657,226	S *	4/2012	Benson et al.	D8/333
D689,358	S *	9/2013	Stevens	D8/343
8,555,682	B2 *	10/2013	Trunek	70/58
2009/0297288	A1	12/2009	Metz et al.	

(\*\*) Term: **14 Years**

(21) Appl. No.: **29/499,450**

\* cited by examiner

(22) Filed: **Aug. 14, 2014**

*Primary Examiner* — Prabhakar Deshmukh

(51) **LOC (10) Cl.** ..... **08-07**

(74) *Attorney, Agent, or Firm* — Kenneth W. Iles

(52) **U.S. Cl.**  
USPC ..... **D8/343; D8/367**

(57) **CLAIM**

(58) **Field of Classification Search**  
USPC ..... D8/330, 331, 333, 334, 339–341, 343,  
D8/349, 367; 70/20, 30, 31, 38 A, 38 R, 51,  
70/52, 57.1, 141, 233, 431  
CPC ..... E05C 19/18; B25G 3/00; B25G 3/02;  
B25G 3/002  
See application file for complete search history.

A ornamental design for an adjustable chain latch, as shown and described.

**DESCRIPTION**

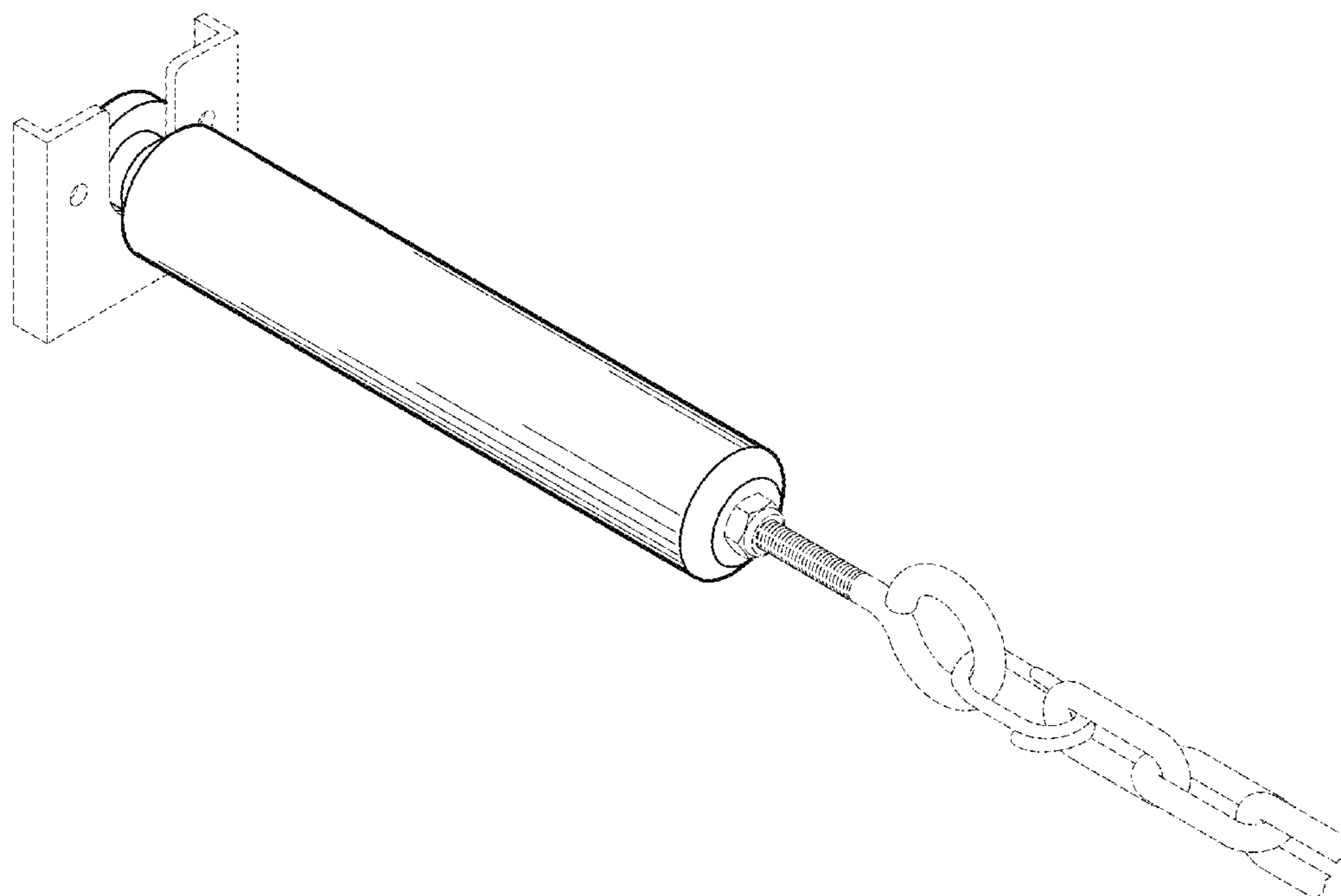
(56) **References Cited**

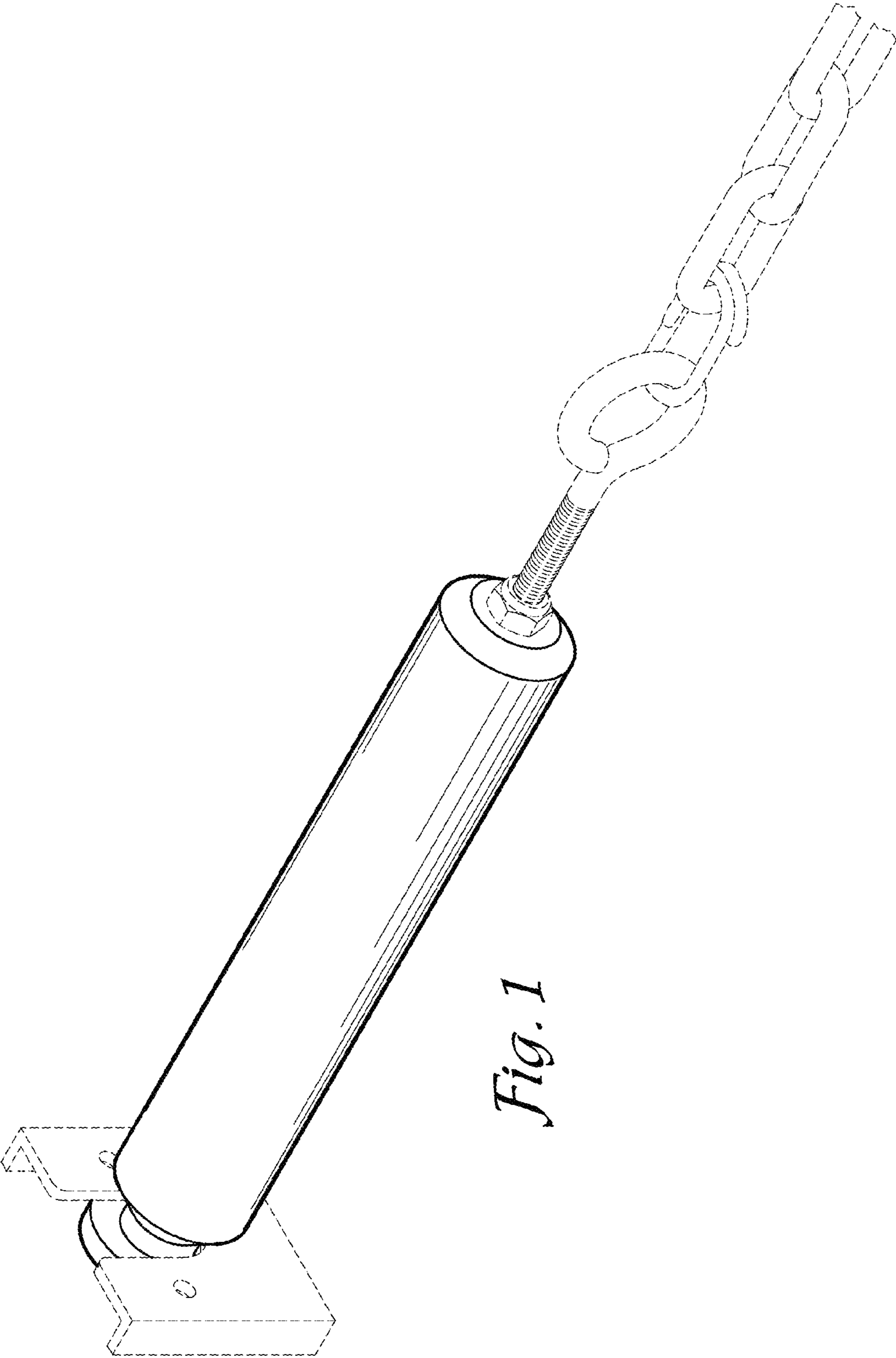
U.S. PATENT DOCUMENTS

1,386,109	A *	8/1921	Hatfield	403/48
2,120,497	A *	6/1938	Heinrich	248/219.4
3,051,519	A *	8/1962	Sudeikis	403/43
3,643,478	A *	2/1972	McPeake	70/212

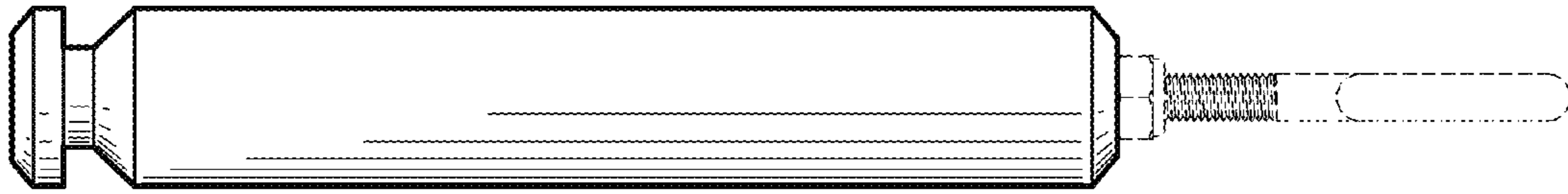
FIG. 1 is an isometric view of the adjustable chain latch showing my new design;  
FIG. 2 is a top view thereof;  
FIG. 3 is a right or left side view thereof;  
FIG. 4 is a bottom view thereof;  
FIG. 5 is a left end view thereof; and,  
FIG. 6 is a right end view thereof.  
The broken line showing is included for the purpose of illustrating environment and forms no part of the claimed design.

**1 Claim, 2 Drawing Sheets**

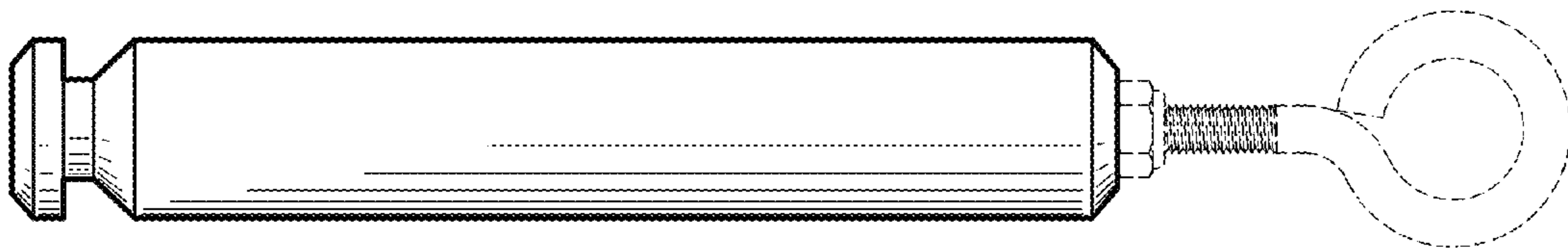




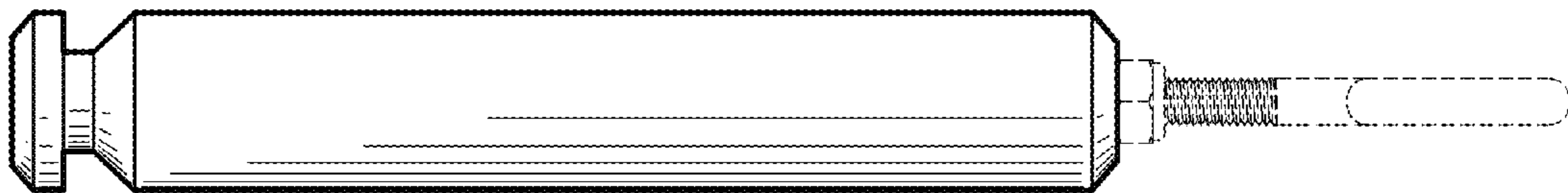
*Fig. 1*



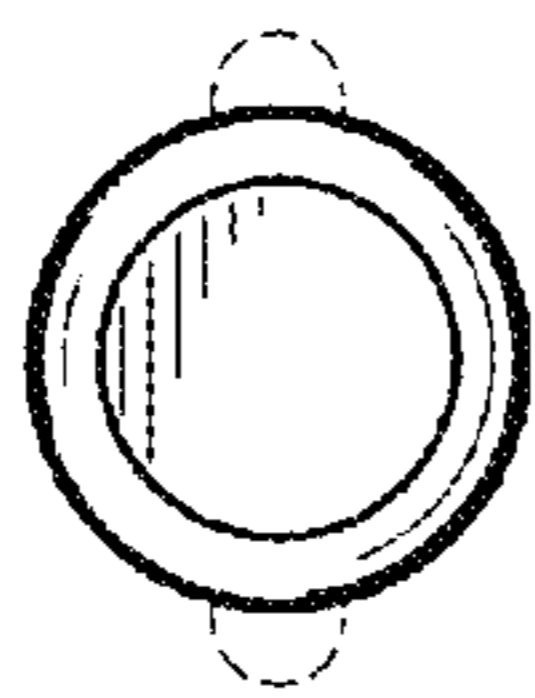
*Fig. 2*



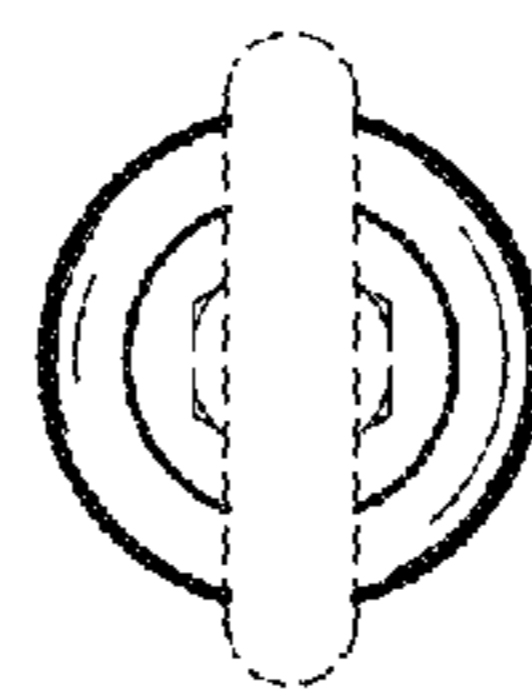
*Fig. 3*



*Fig. 4*



*Fig. 5*



*Fig. 6*