



US00D736140S

(12) **United States Design Patent**
Moller

(10) **Patent No.:** **US D736,140 S**

(45) **Date of Patent:** **** Aug. 11, 2015**

(54) **VERTICAL TAKEOFF AND LANDING VEHICLE**

(71) Applicant: **Paul S. Moller**, Davis, CA (US)

(72) Inventor: **Paul S. Moller**, Davis, CA (US)

(73) Assignee: **MOLLER International, Inc.**, Davis, CA (US)

(**) Term: **14 Years**

(21) Appl. No.: **29/465,020**

(22) Filed: **Aug. 23, 2013**

(51) **LOC (10) Cl.** **12-07**

(52) **U.S. Cl.**
USPC **D12/326; D12/330**

(58) **Field of Classification Search**
USPC D12/319, 326, 327, 328, 331, 333, 334, D12/337, 339, 341, 344, 345; D21/442, D21/447, 450; 244/6, 7 A, 7 R, 7 C, 12.1, 244/12.3, 12.4, 12.5, 12.6, 13, 45 R, 56, 60, 244/199.4; 446/35, 36, 57, 225
CPC B64C 27/00; B64C 27/22; B64C 29/00; B64C 29/0016; B64C 29/0033; B64C 39/00; B64C 30/06; B64C 39/066; B64C 39/08; B64C 3/00; B64C 3/10
See application file for complete search history.

(56) **References Cited**

U.S. PATENT DOCUMENTS

2,194,596	A *	3/1940	Henter	244/13
4,358,074	A *	11/1982	Schoen et al.	244/12.4
4,804,155	A *	2/1989	Strumbos	244/12.6
D312,068	S	11/1990	Moller		
5,115,996	A	5/1992	Moller		
5,503,352	A *	4/1996	Eger	244/45 R
6,808,140	B2	10/2004	Moller		
D498,201	S	11/2004	Moller		
6,886,776	B2 *	5/2005	Wagner et al.	244/12.4
7,472,863	B2 *	1/2009	Pak	244/12.5

7,644,892	B1 *	1/2010	Alford et al.	244/199.4
7,874,513	B1 *	1/2011	Smith	244/12.4
D634,257	S *	3/2011	Alexander	D12/326
8,152,096	B2 *	4/2012	Smith	244/60
2004/0026563	A1 *	2/2004	Moller	244/12.4
2010/0019081	A1 *	1/2010	Cazals et al.	244/56
2012/0234968	A1 *	9/2012	Smith	244/12.3

* cited by examiner

Primary Examiner — Martie K Holtje

(74) *Attorney, Agent, or Firm* — Claude A. S. Hamrick

(57) **CLAIM**

The ornamental design for a vertical takeoff and landing vehicle, as shown and described.

DESCRIPTION

FIG. 1 is a top, right front perspective view of a vertical takeoff and landing vehicle showing my new design; FIG. 2 is a right side elevational view thereof; FIG. 3 is a front elevational view thereof; FIG. 4 is a rear elevational view thereof; FIG. 5 is a top plan view thereof; FIG. 6 is a bottom plan view thereof; FIG. 7 is a right side elevational view thereof showing the nacelles rotated upwardly into a take-off or landing position; FIG. 8 is a front elevational view of FIG. 7; FIG. 9 is a right side elevational view similar to FIG. 2, with the wings rotated upwardly in a folded storage position; and, FIG. 10 is a front elevational view similar to FIG. 3, with the wings rotated upwardly into a folded storage position. The dashed lines shown in FIGS. 1, 3, 4, 8 and 10 represent propeller blades contained within the nacelles and are included to show the open characteristic of the nacelle air flow passageways and are specifically disclaimed as not forming a part of the claimed design. The propeller blades depicted by broken lines in FIGS. 1, 3, 4, 8, and 10 have been shown for the purpose of illustrating portions of the vertical takeoff and landing vehicle that form no part of the claimed design.

1 Claim, 4 Drawing Sheets

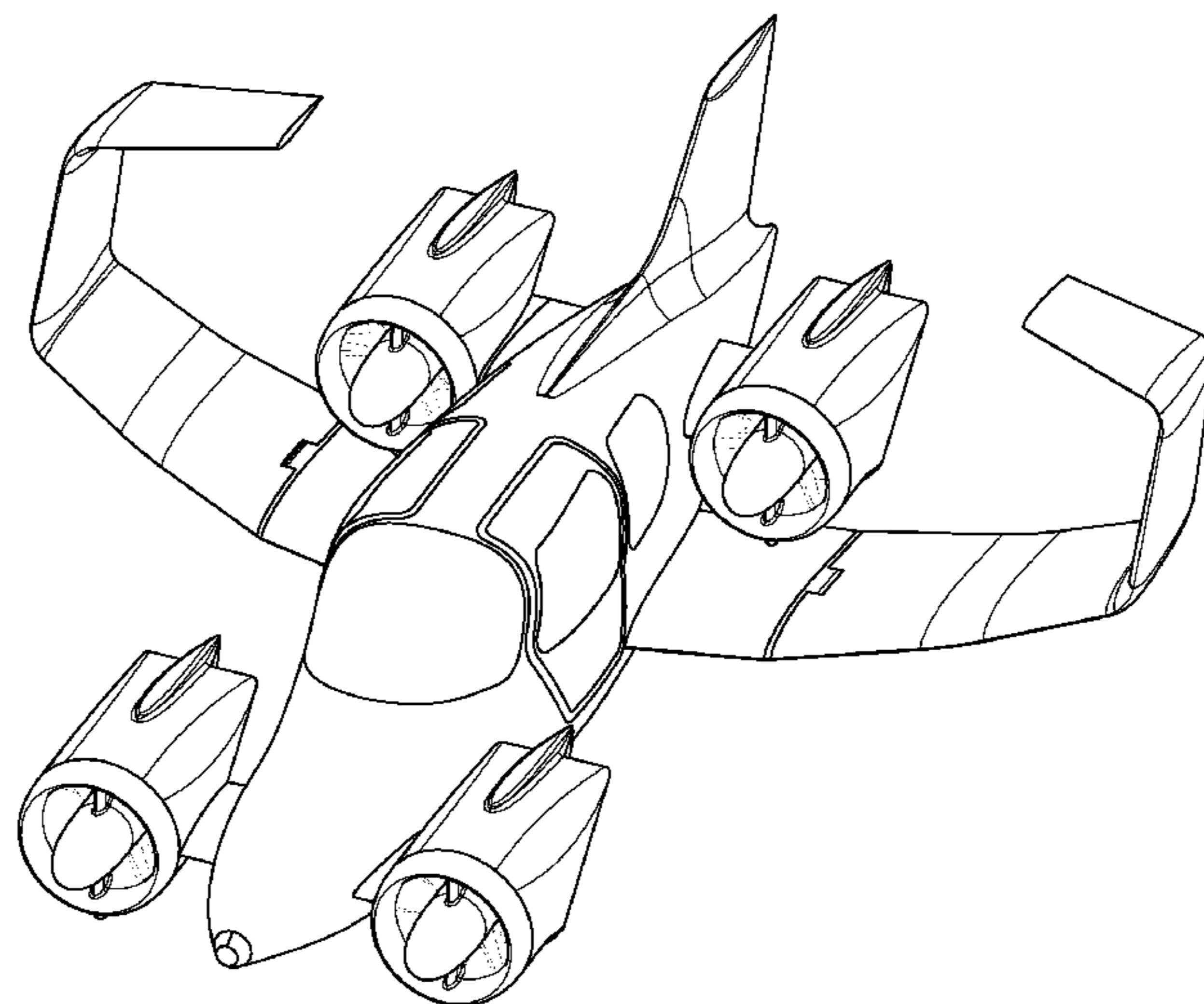

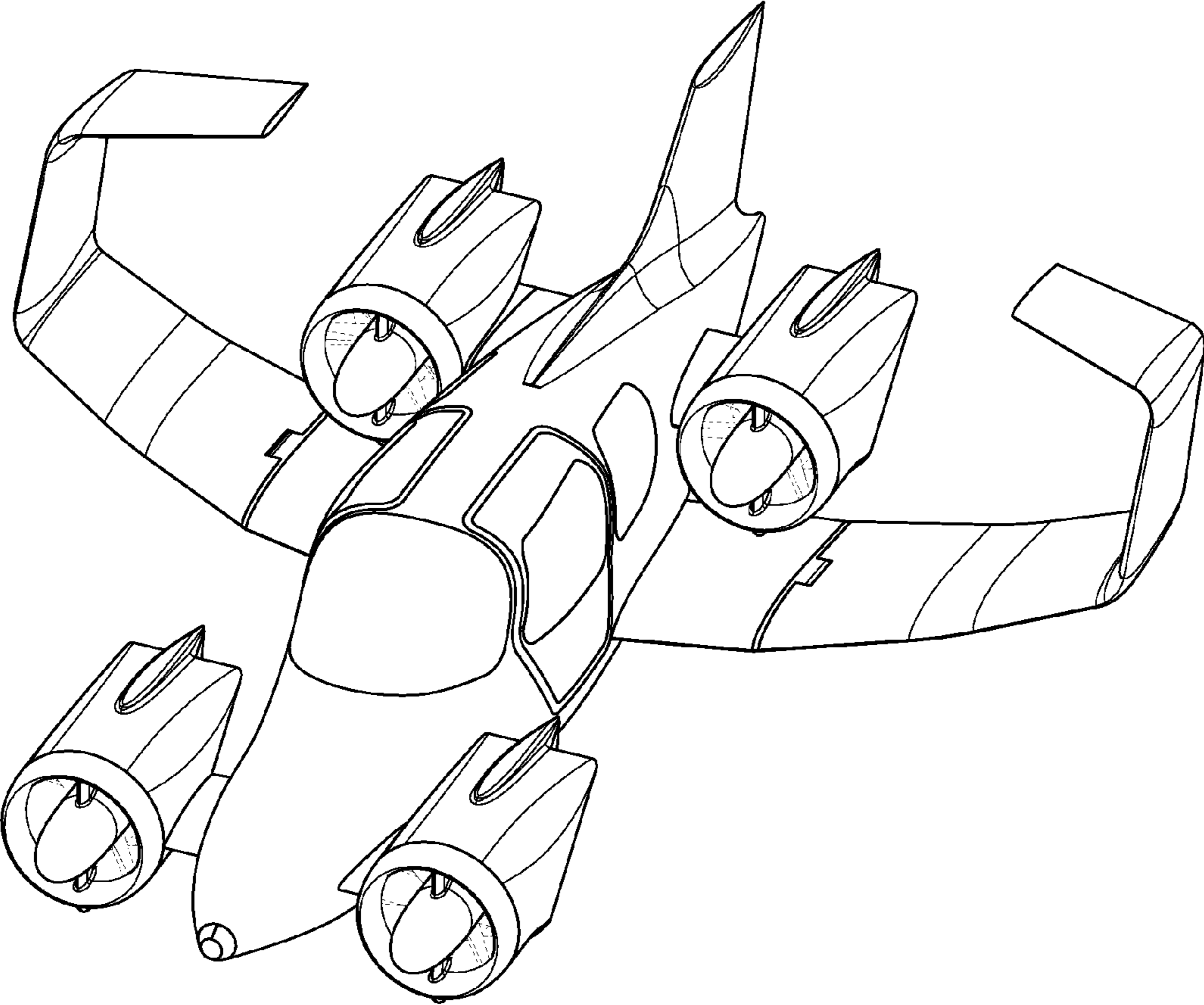

FIG. 1

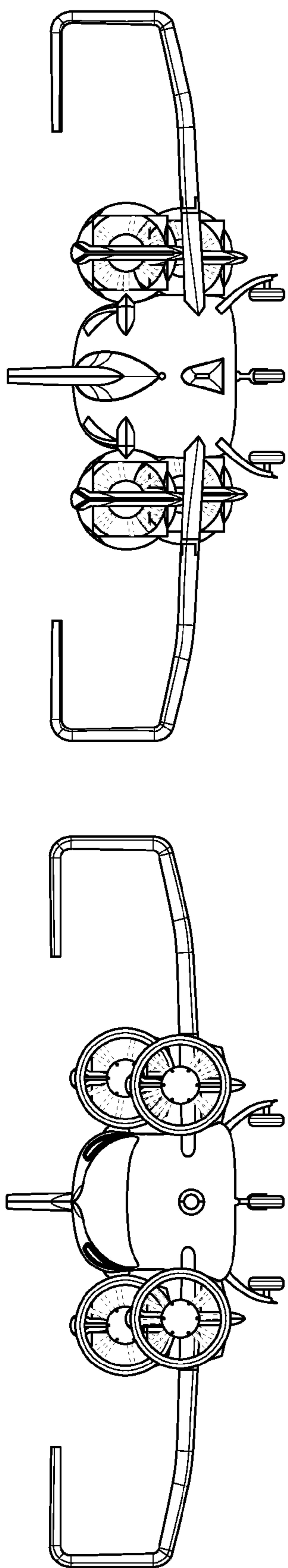

FIG. 4

FIG. 3

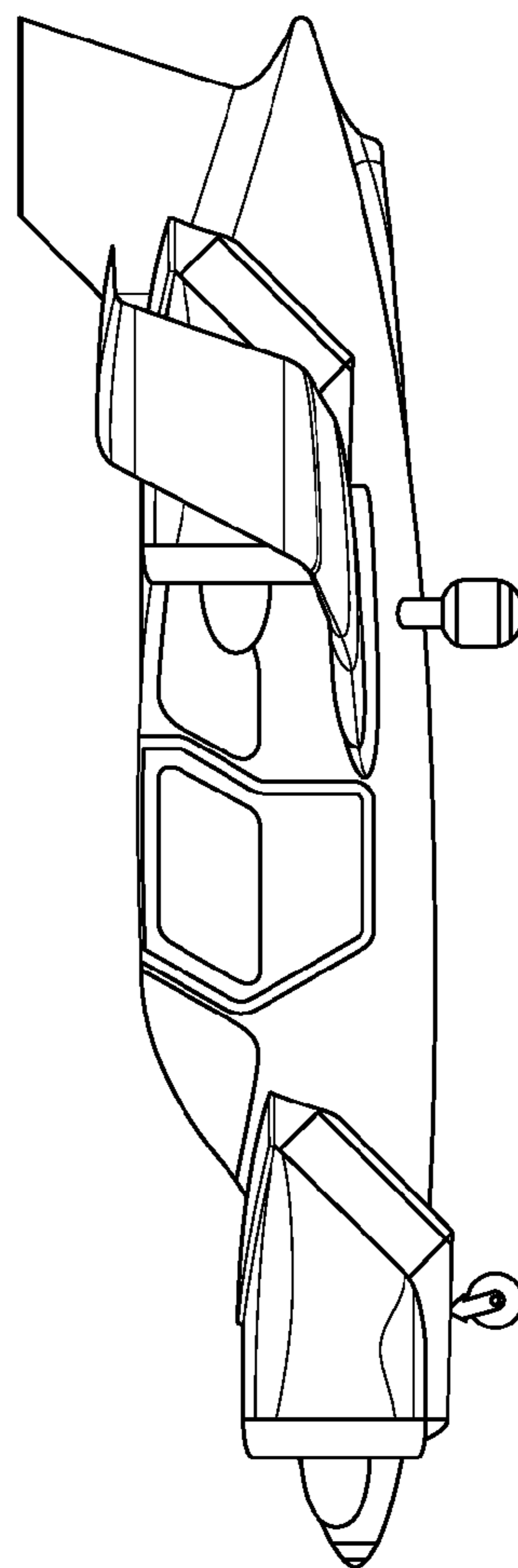

FIG. 2

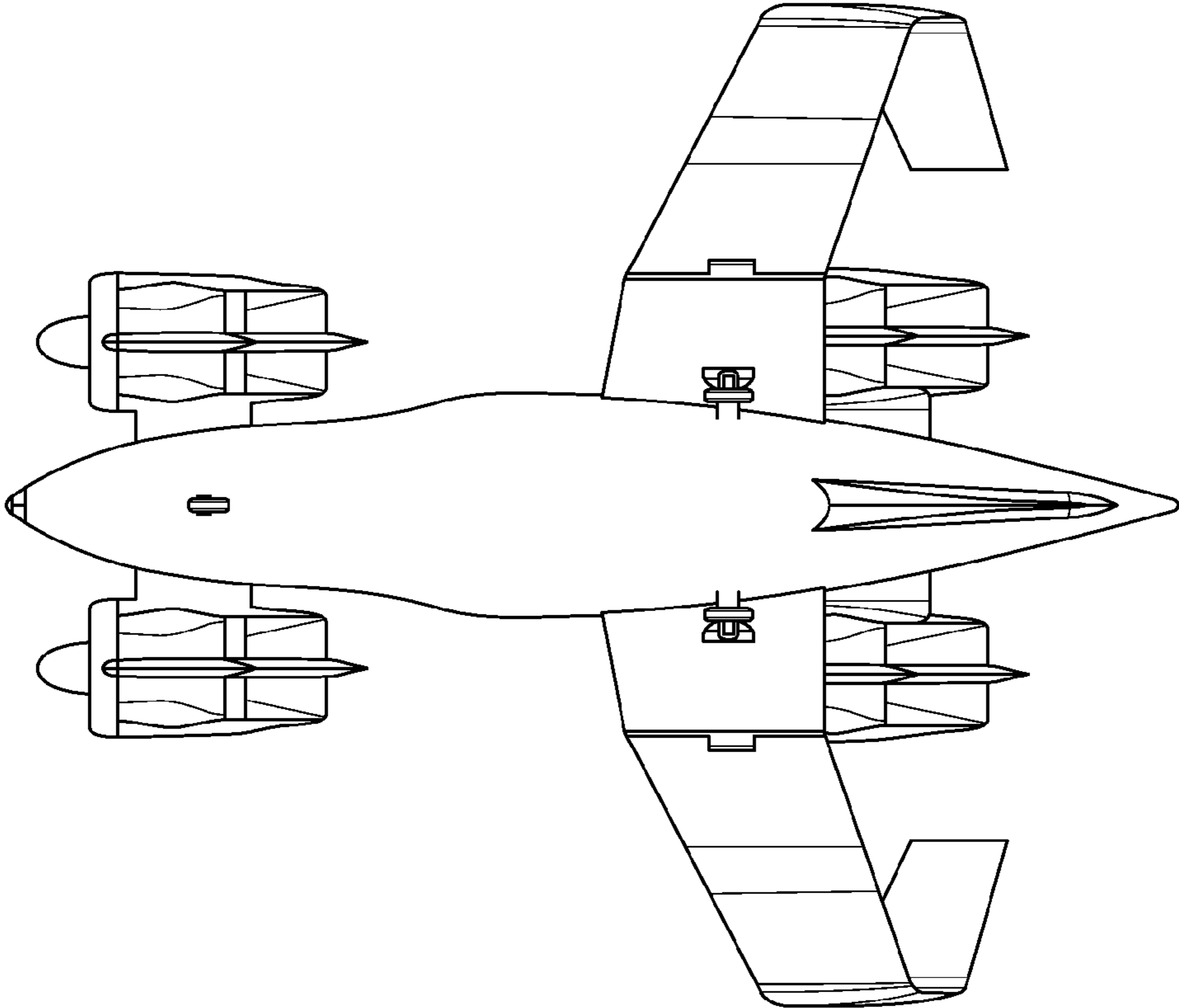

FIG. 6

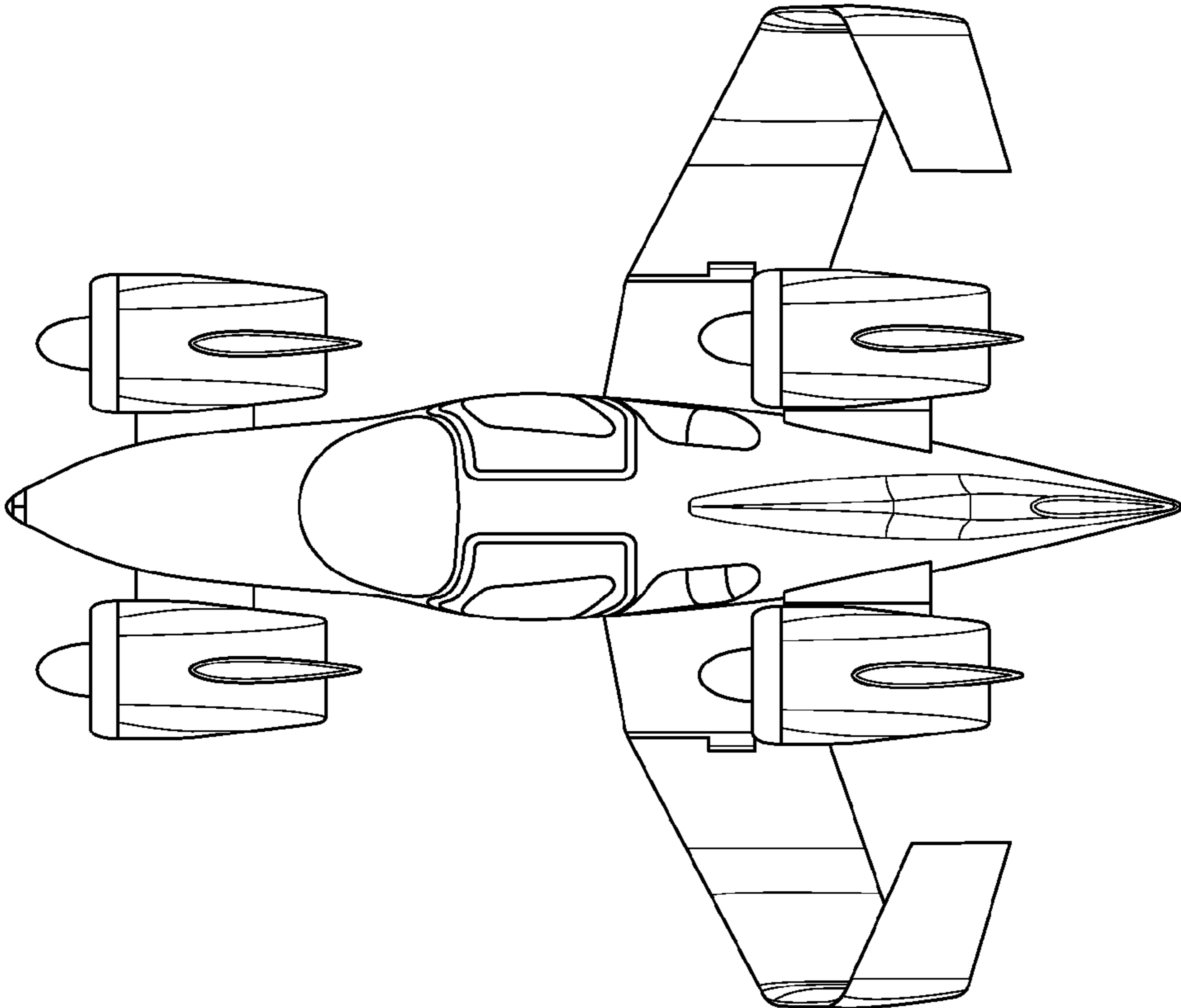

FIG. 5

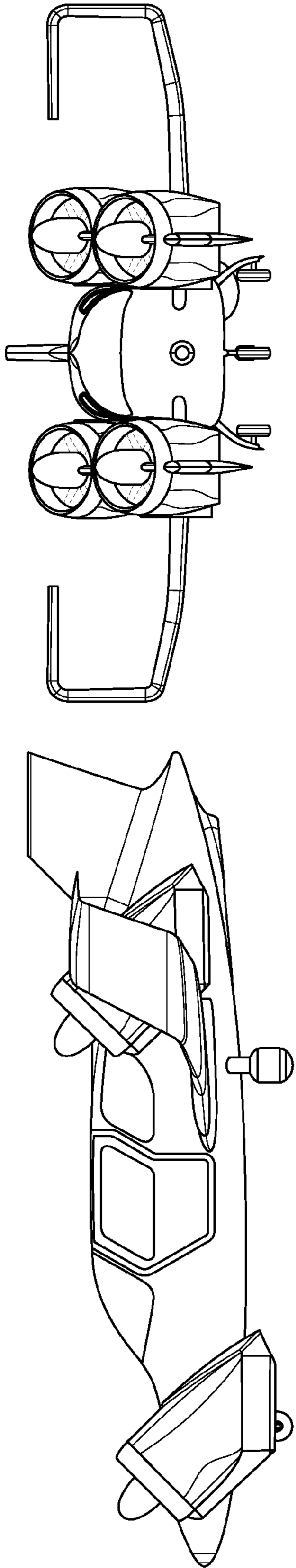

FIG. 8

FIG. 7

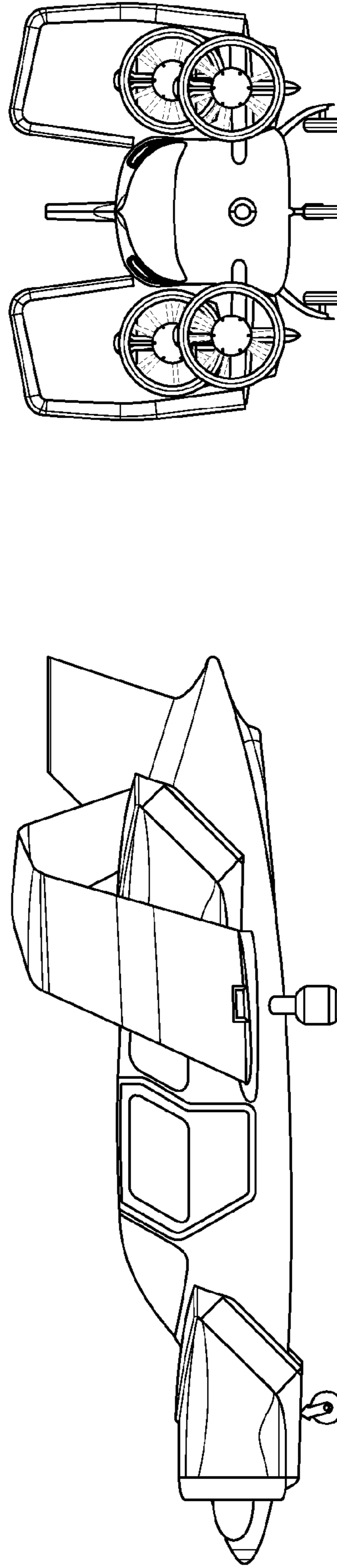

FIG. 9

FIG. 10