



US00D736004S

(12) **United States Design Patent**  
**Pinkstone et al.**

(10) **Patent No.:** **US D736,004 S**

(45) **Date of Patent:** **\*\* Aug. 11, 2015**

(54) **AIRPLANE SEATING UNIT**

(56) **References Cited**

(71) Applicant: **Zodiac Seats UK Limited**, Wales  
Cwmbran (GB)

U.S. PATENT DOCUMENTS

(72) Inventors: **Andrew Pinkstone**, Torfaen (GB);  
**Andrew Peel**, Carmathenshire (GB)

D98,628 S *	2/1936	Stark et al. ....	D6/337
D128,165 S *	7/1941	Jory .....	D6/337
D260,823 S *	9/1981	Stulik, Jr. ....	D6/335
D262,165 S *	12/1981	Andries et al. ....	D6/335
D467,754 S *	12/2002	Chen .....	D6/429
D563,114 S *	3/2008	Pegg .....	D6/406.1
D565,848 S *	4/2008	Newhouse .....	D6/338
D565,849 S *	4/2008	Newhouse .....	D6/338
D565,850 S *	4/2008	Newhouse .....	D6/338
D588,829 S *	3/2009	Rheault et al. ....	D6/406.1
D616,209 S *	5/2010	Singler et al. ....	D6/338
D720,160 S *	12/2014	Lloyd et al. ....	D6/643

(73) Assignee: **Zodiac Seats UK Limited**, Cwmbran,  
Wales (GB)

(\*\*) Term: **14 Years**

\* cited by examiner

(21) Appl. No.: **29/486,994**

*Primary Examiner* — Sandra Snapp

(22) Filed: **Apr. 4, 2014**

(74) *Attorney, Agent, or Firm* — Kilpatrick Townsend &  
Stockton LLP; Dean W. Russell; Tiffany L. Williams

(51) **LOC (10) Cl.** ..... **06-01**

(57) **CLAIM**

(52) **U.S. Cl.**

The ornamental design for an airplane seating unit, as shown  
and described.

USPC ..... **D6/338**

**DESCRIPTION**

(58) **Field of Classification Search**

USPC ..... D6/334, 335, 336, 379, 381, 369, 349,  
D6/370, 337, 338, 640, 643, 643.1, 644,  
D6/406.1, 406.2, 406.3; 297/94, 118, 232,  
297/445.1, 448.1, DIG. 7  
CPC ..... A47C 17/00; A47C 17/02; A47C 17/12;  
A47C 17/18; A47C 7/021; A47C 31/00;  
A47C 3/16

FIG. 1 is an isometric view of an airplane seating unit.  
FIG. 2 is a side view of the airplane seating unit of FIG. 1.  
FIG. 3 is another side view of the airplane seating unit of FIG. 1,  
opposite the side view of FIG. 2.  
FIG. 4 is an end view of the airplane seating unit of FIG. 1.  
FIG. 5 is another end view of the airplane seating unit of FIG. 1,  
opposite the end view of FIG. 4; and,  
FIG. 6 is a top view of the airplane seating unit of FIG. 1.  
The broken lines form no part of the claimed design.

See application file for complete search history.

**1 Claim, 6 Drawing Sheets**

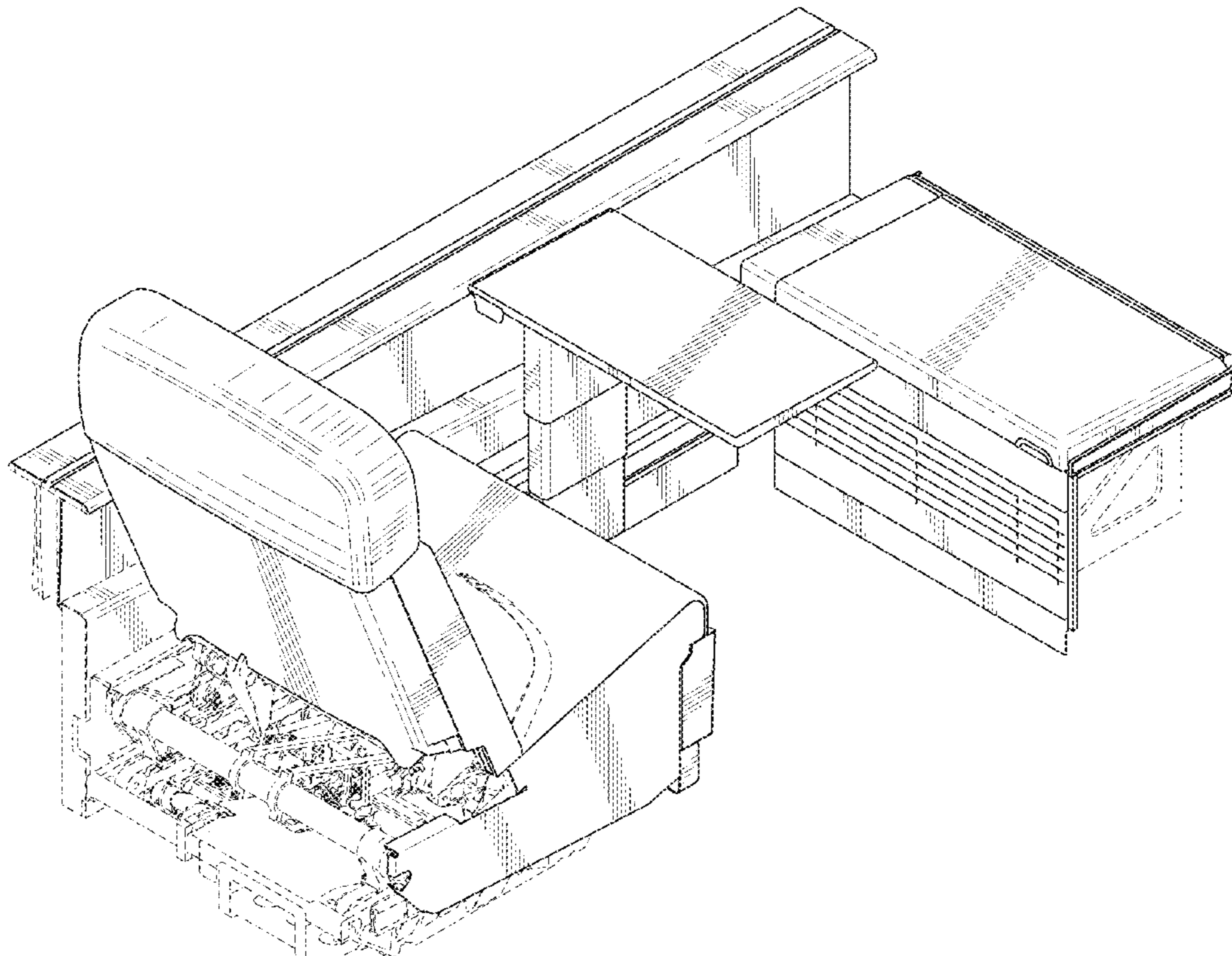

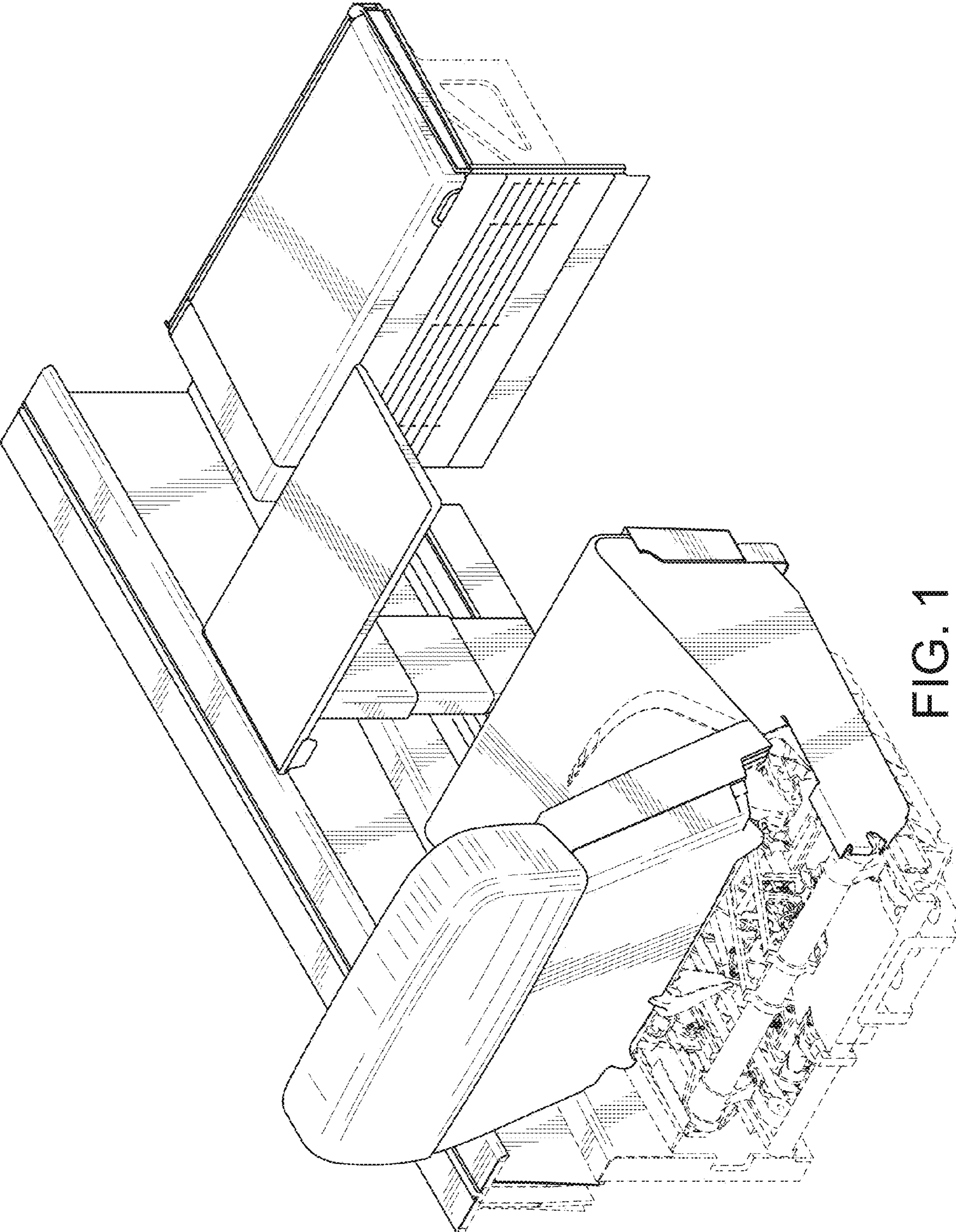

FIG. 1

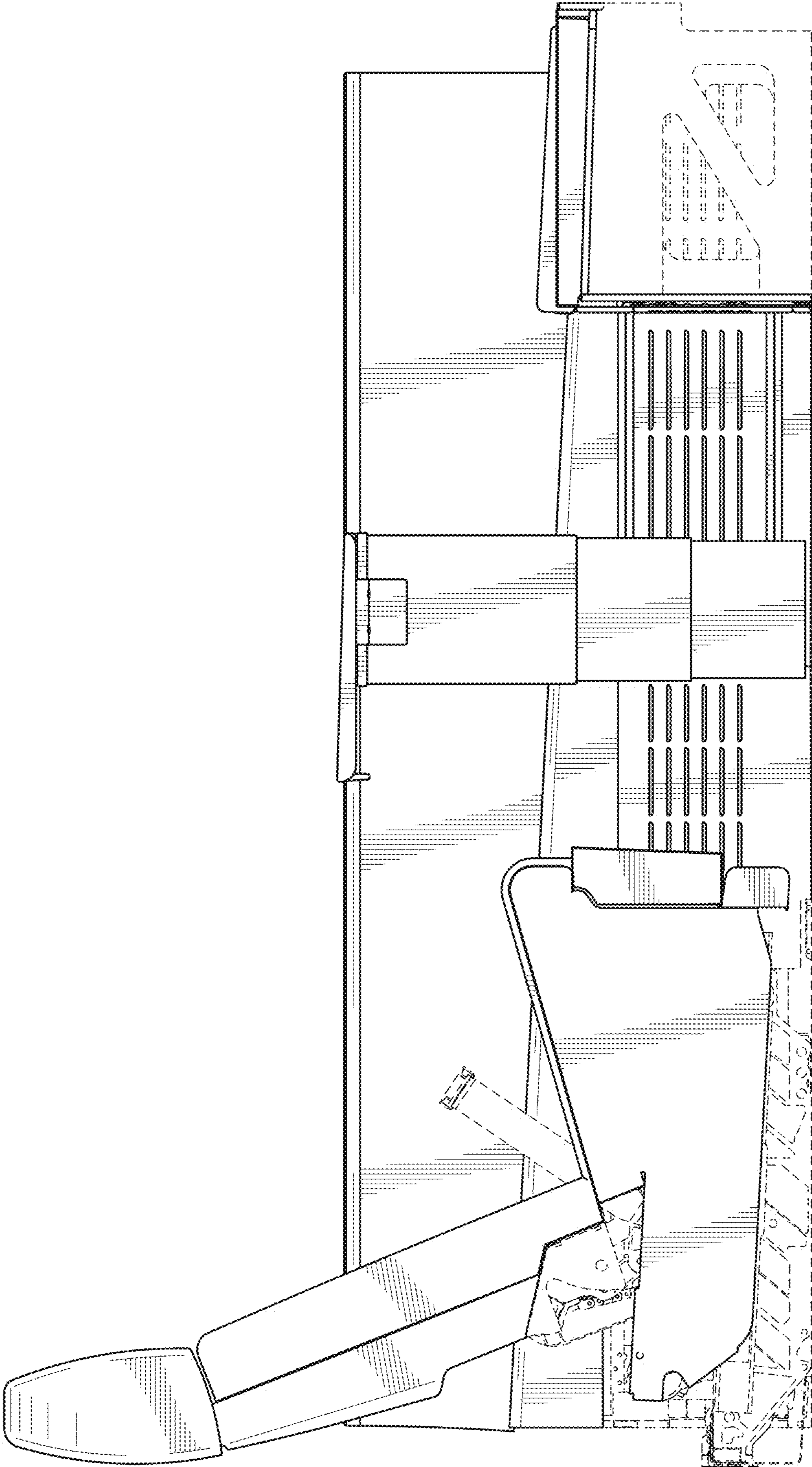

FIG. 2

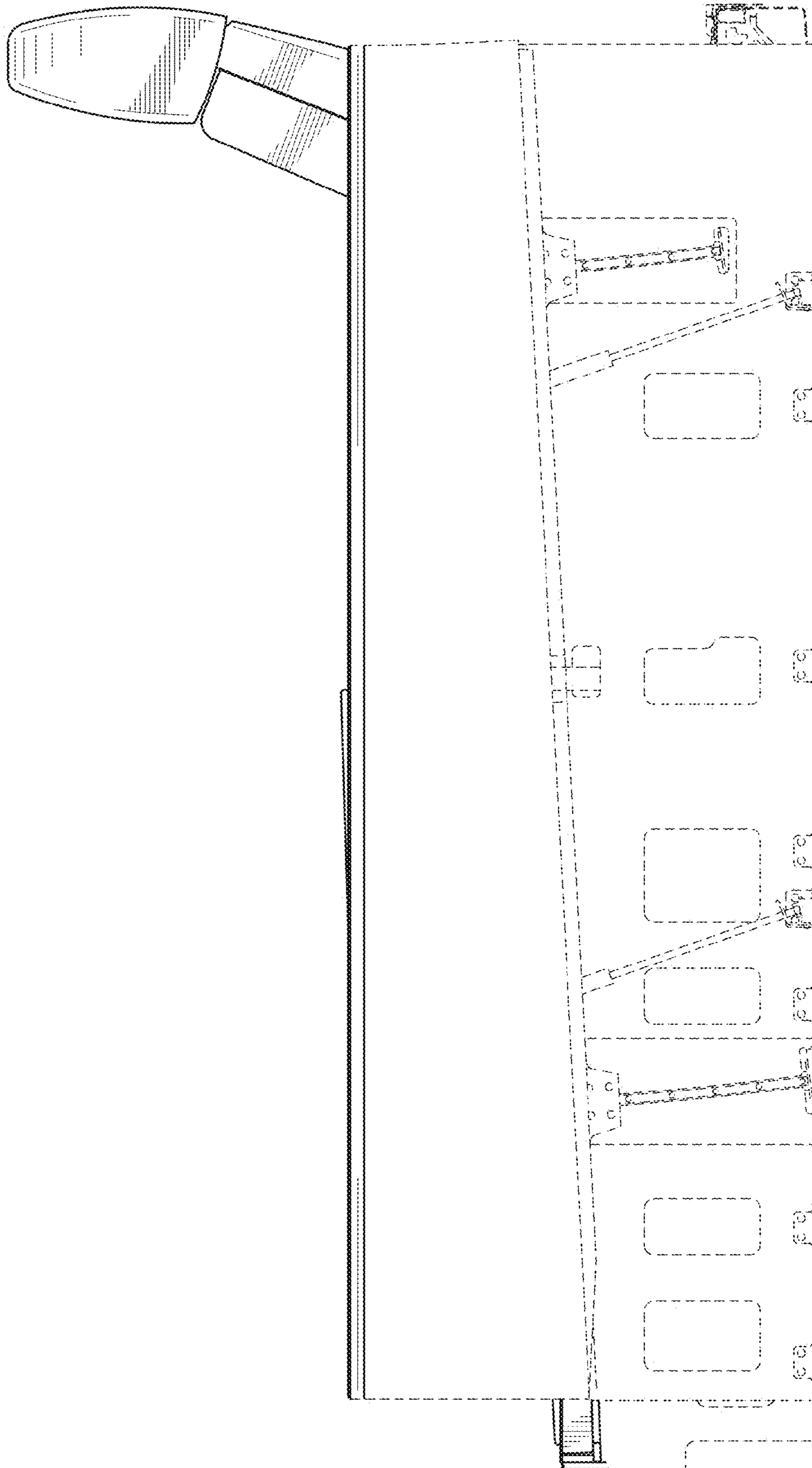

FIG. 3

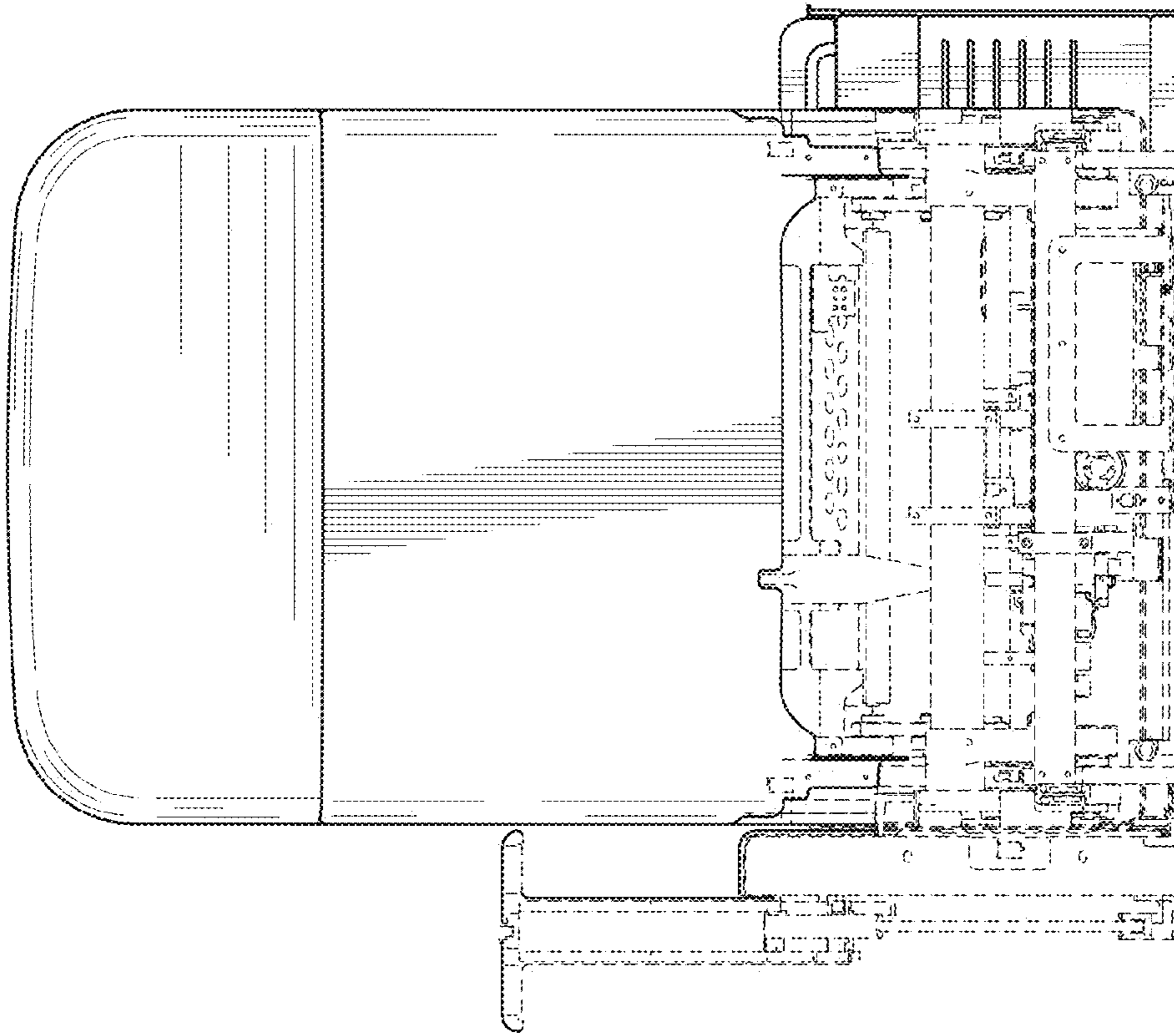

FIG. 4

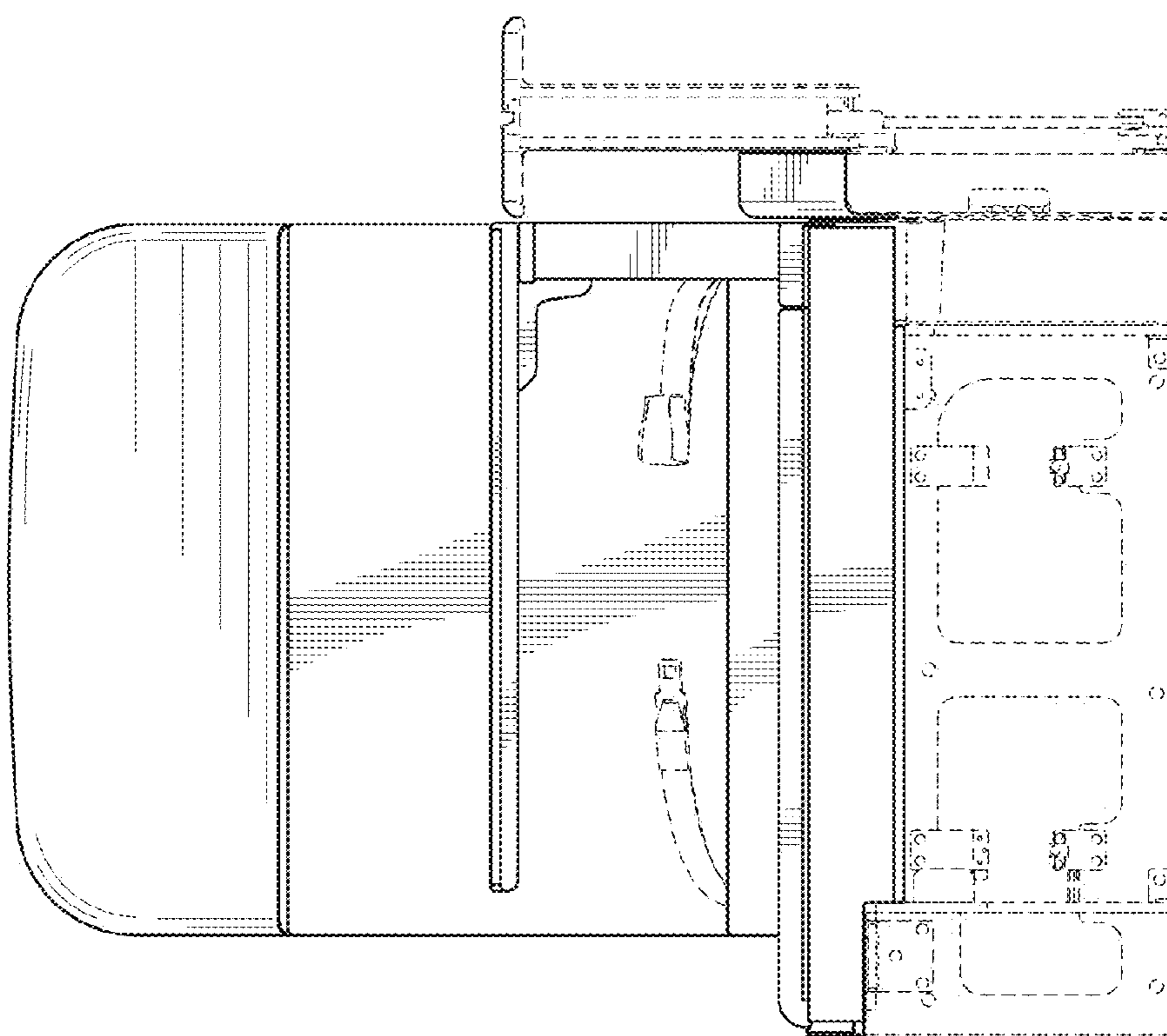

FIG. 5

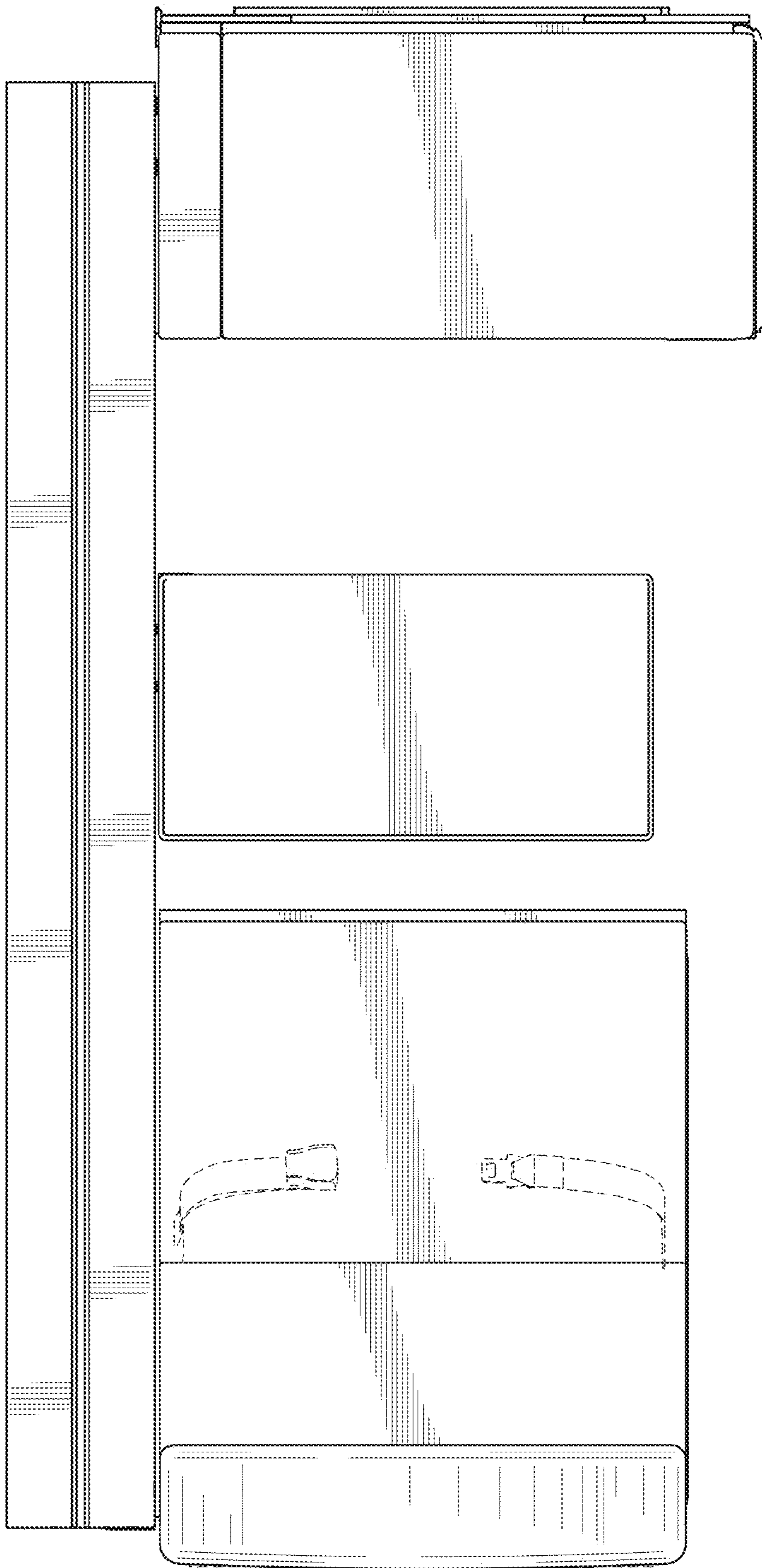

FIG. 6