



US00D735908S

(12) **United States Design Patent**
Ko

(10) **Patent No.:** **US D735,908 S**

(45) **Date of Patent:** **** Aug. 4, 2015**

(54) **LIGHT FOR VEHICLE**

(56) **References Cited**

(71) Applicant: **VISION MOTOR SPORTS, INC.**,
Algona, WA (US)

U.S. PATENT DOCUMENTS

(72) Inventor: **In-Hong Ko**, Incheon (KR)

D490,172	S	*	5/2004	Yamamoto	D26/28
D564,683	S	*	3/2008	Roach et al.	D26/28
D570,009	S	*	5/2008	Kani et al.	D26/28
D638,963	S	*	5/2011	Huang	D26/28
D704,363	S	*	5/2014	Adams	D26/28
D704,365	S	*	5/2014	Adams	D26/28
D718,478	S	*	11/2014	Adams	D26/28
D722,713	S	*	2/2015	Burns	D26/28

(73) Assignee: **VISION MOTOR SPORTS, INC.**,
Algona, WA (US)

(**) Term: **14 Years**

* cited by examiner

(21) Appl. No.: **29/462,869**

Primary Examiner — Wan Laymon

(22) Filed: **Aug. 9, 2013**

(74) *Attorney, Agent, or Firm* — Barnes & Thornburg LLP;
Mark J. Nahnsen

(30) **Foreign Application Priority Data**

Apr. 15, 2013 (KR) 30-2013-0019599

(51) **LOC (10) Cl.** **26-06**

(57) **CLAIM**

The ornamental design for a light for vehicle, as shown and described.

(52) **U.S. Cl.**

USPC **D26/28**

DESCRIPTION

(58) **Field of Classification Search**

USPC D26/28-36; 362/459-460, 464-466,
362/467, 475-477, 478, 485-487

CPC B60A 1/08; B60Q 1/16; B60Q 1/04;
B60Q 1/122; B60Q 1/30; B60Q 1/32; B60Q
11/005; B60Q 1/24; B60Q 1/0035; B60Q
1/2665; B60Q 1/2696; B60Q 3/004; F21S
48/215; F21S 48/10; F21S 48/1145; F21W
2101/02; B62J 6/04; B61L 15/02

FIG. 1 is a perspective view of a light for vehicle;
FIG. 2 is a side elevational view thereof;
FIG. 3 is another side elevational view thereof;
FIG. 4 is a bottom view thereof;
FIG. 5 is a top view thereof;
FIG. 6 is a front elevational view thereof; and,
FIG. 7 is a rear elevational view thereof.

See application file for complete search history.

1 Claim, 7 Drawing Sheets

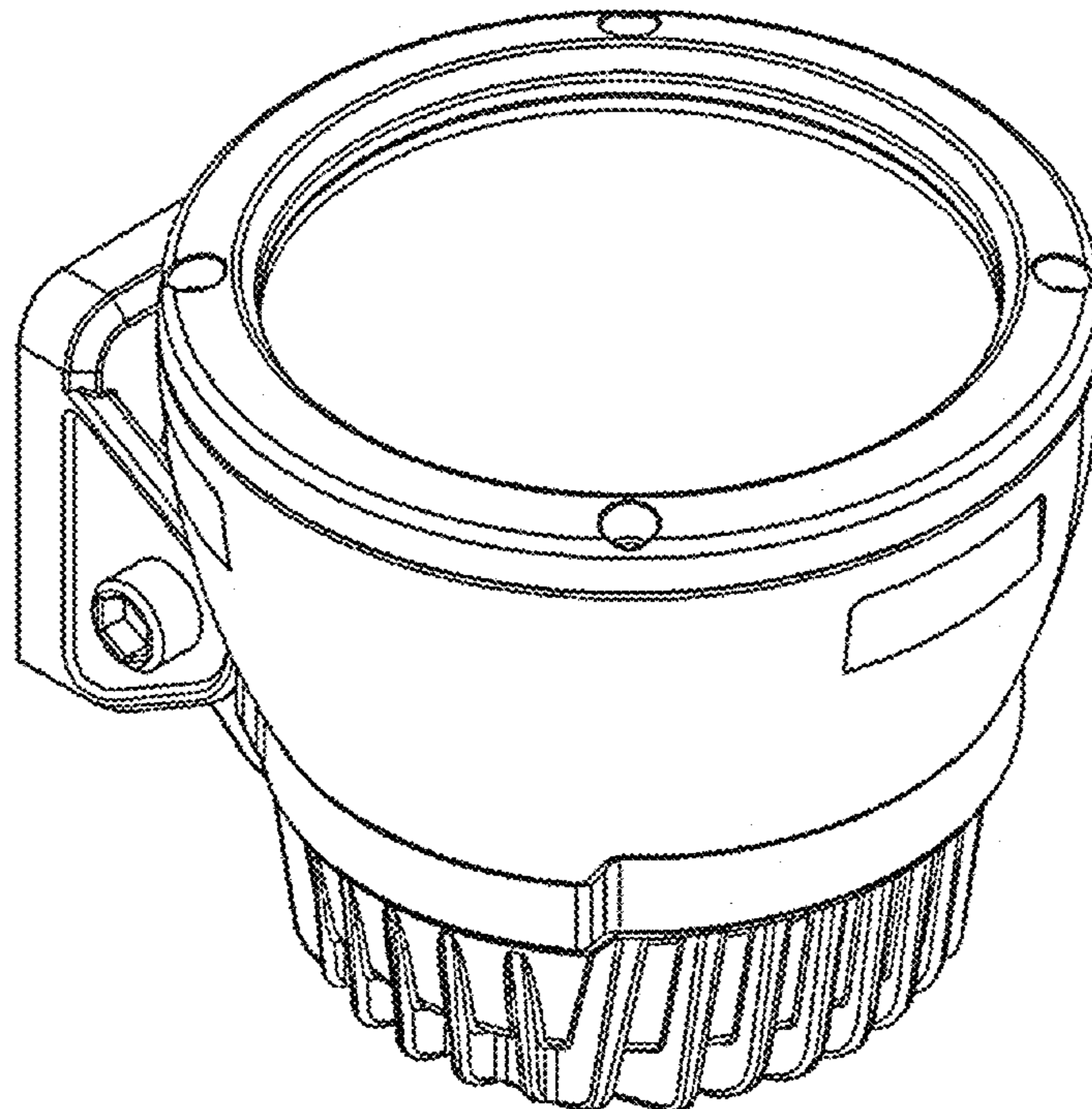

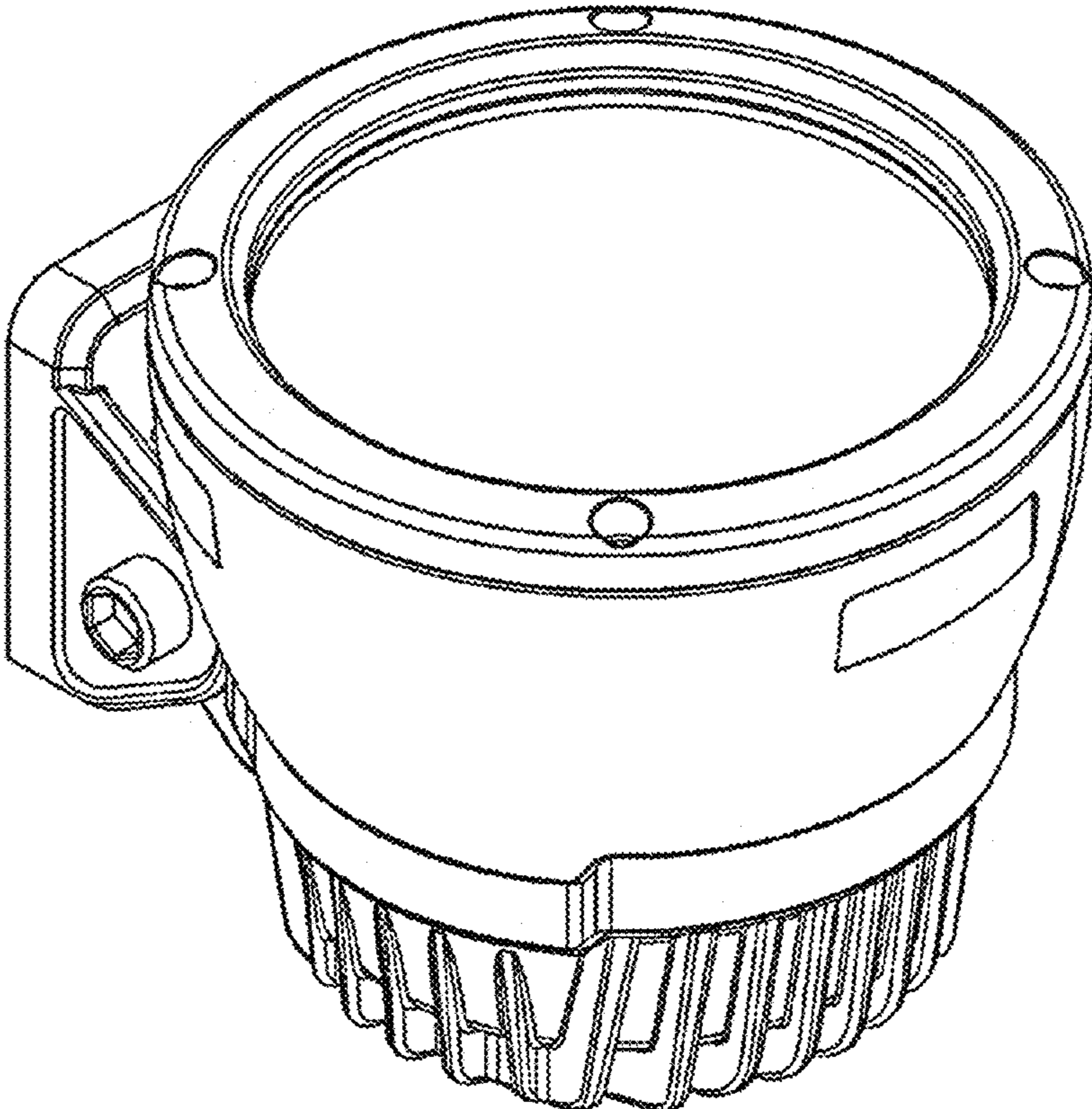

FIG. 1

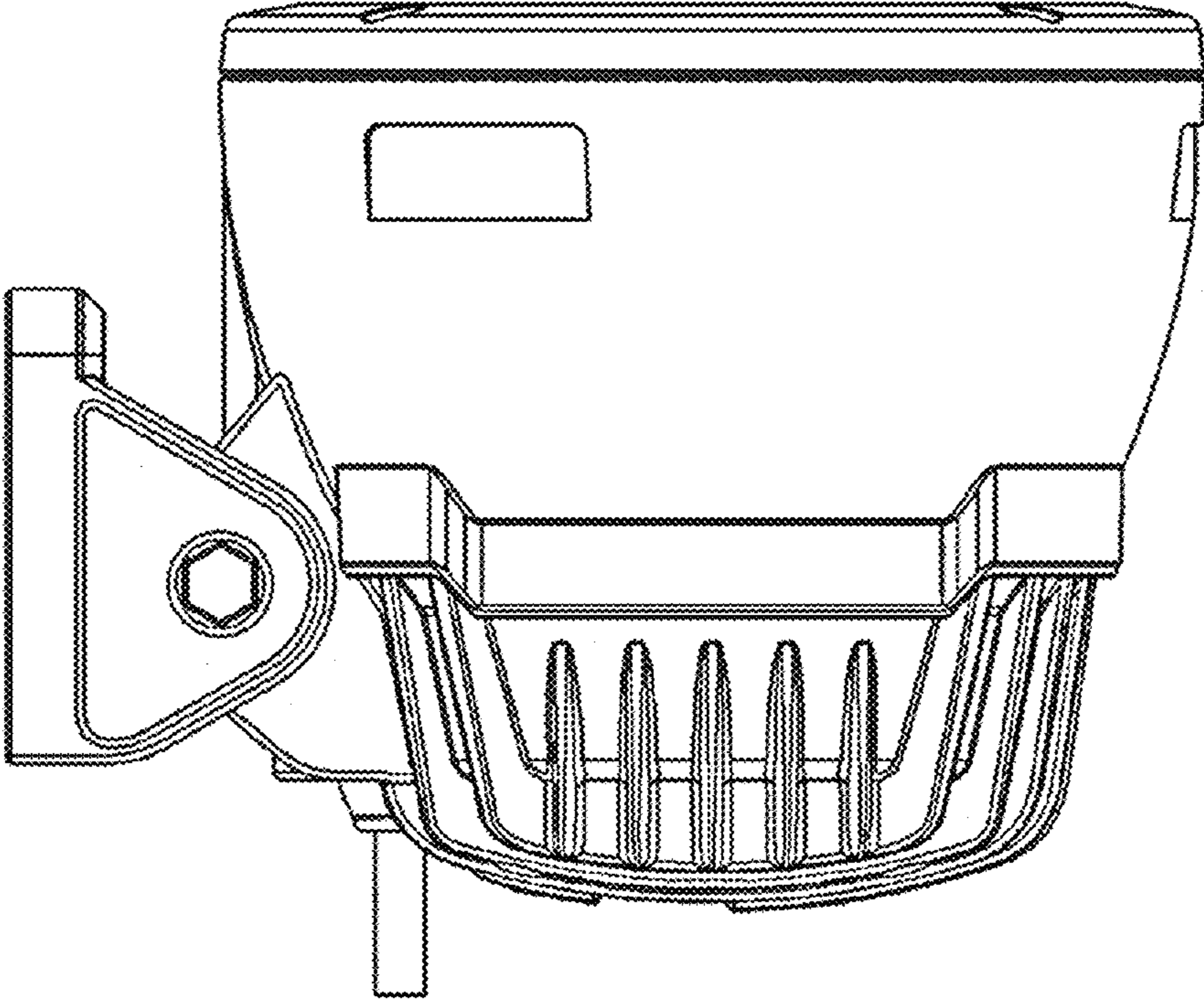

FIG. 2

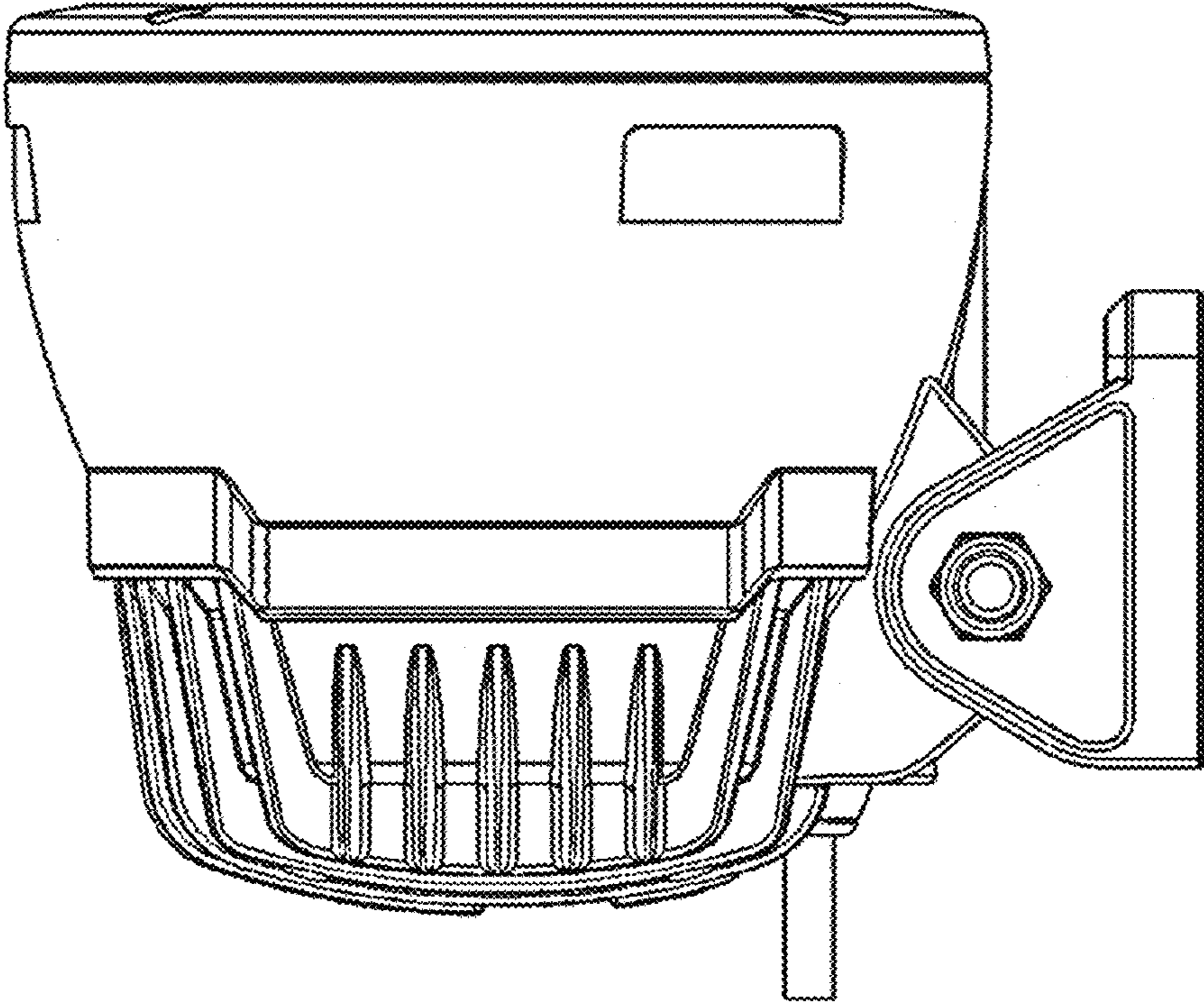

FIG. 3

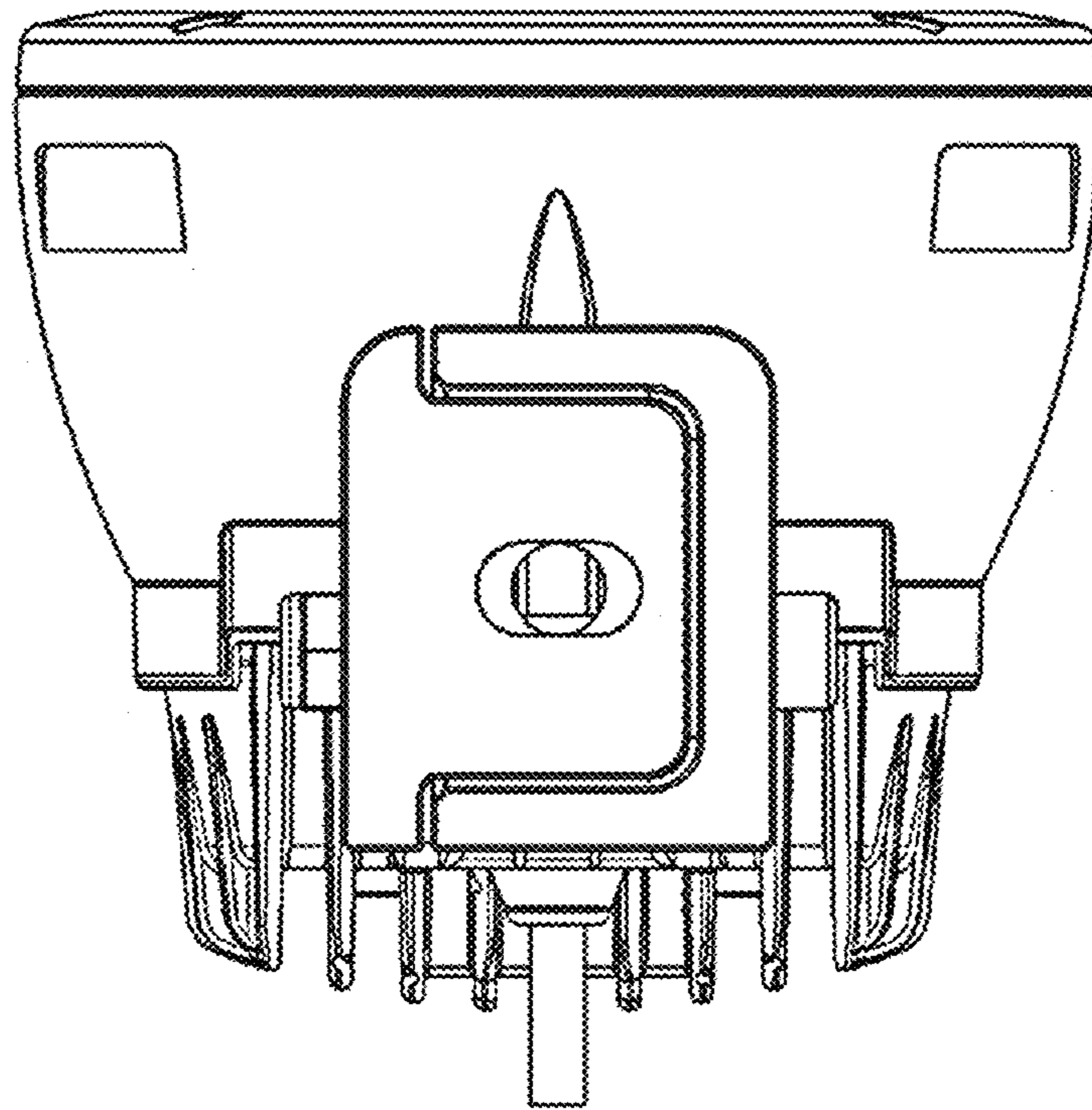

FIG. 4

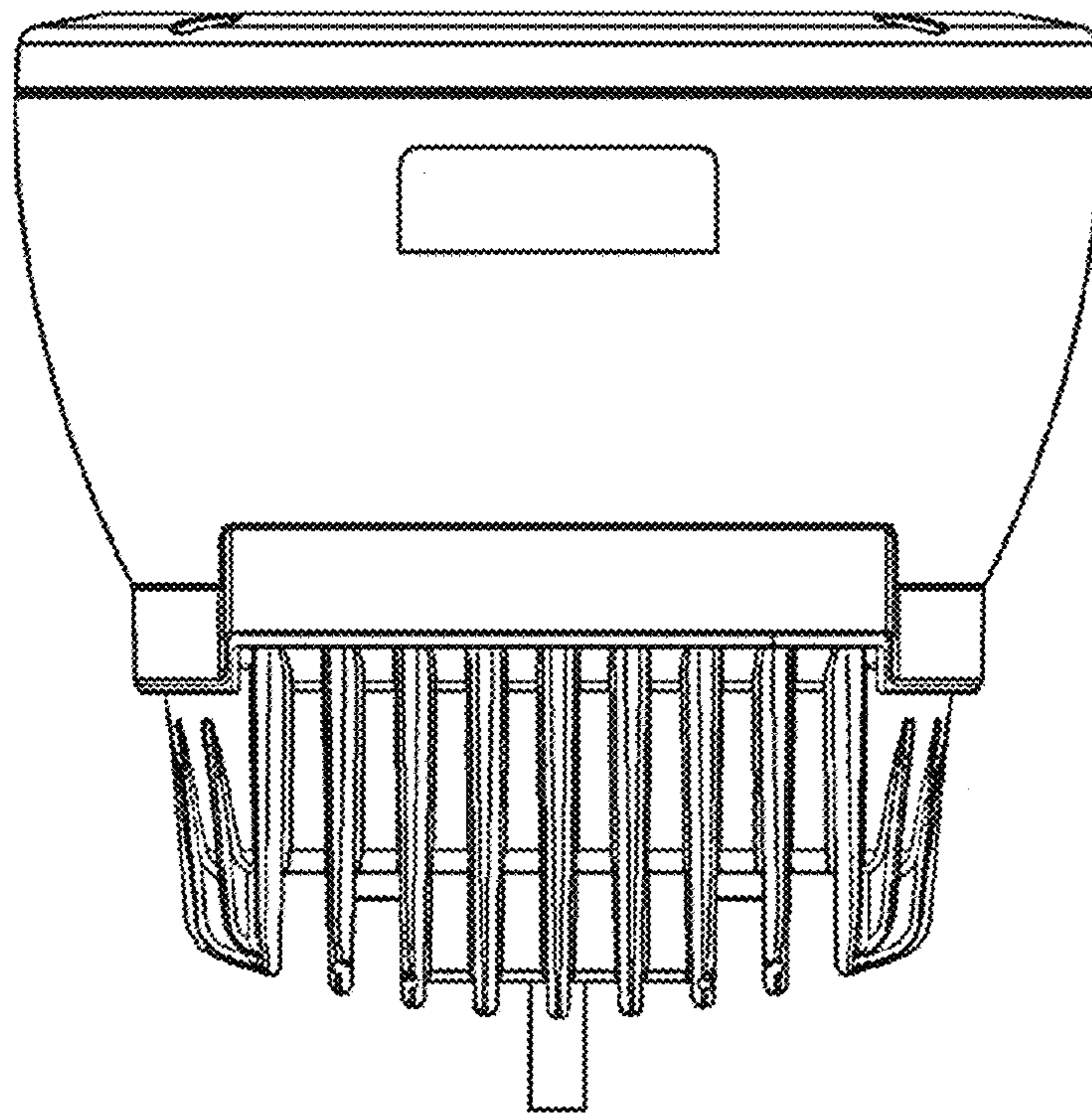

FIG. 5

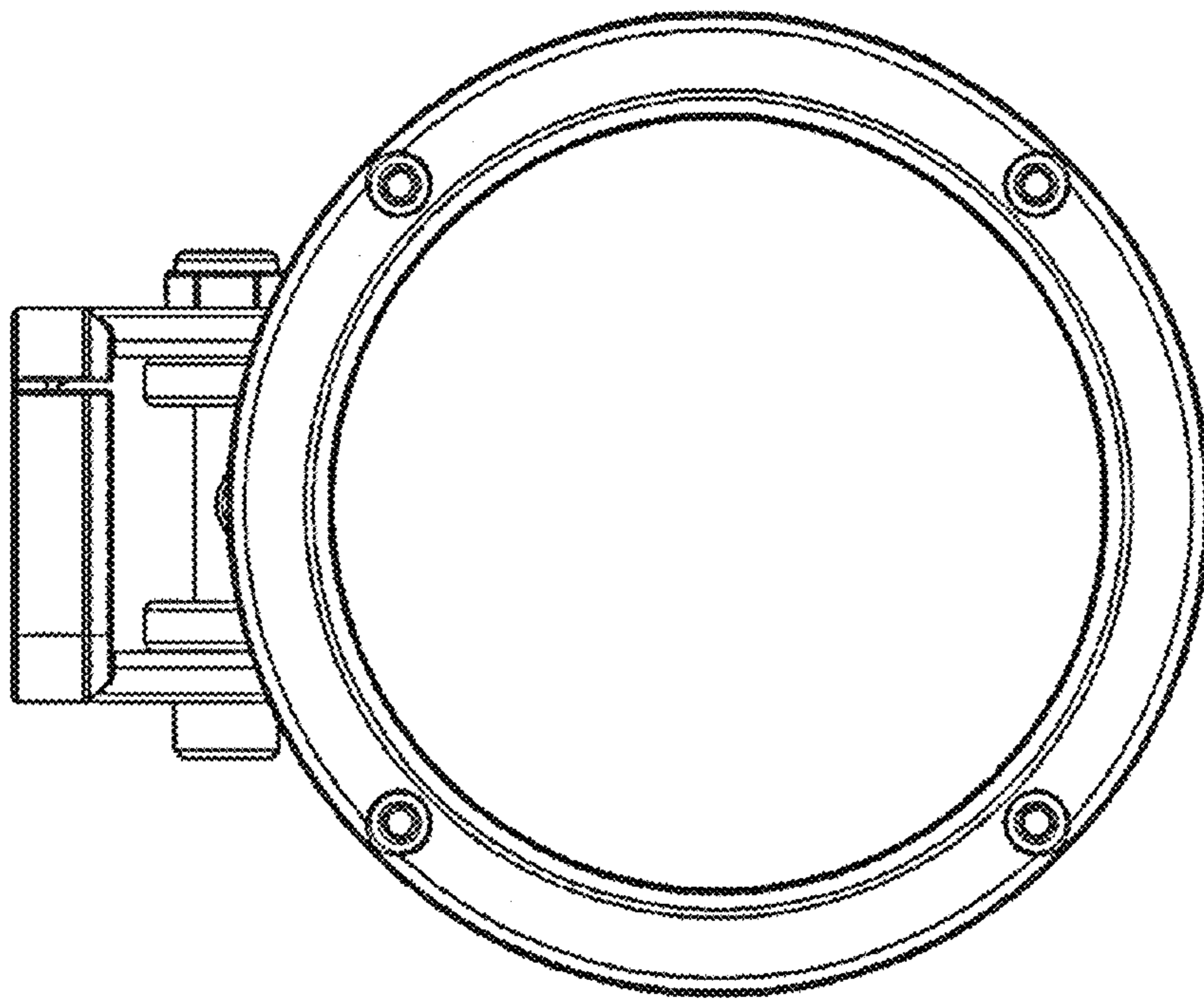

FIG. 6

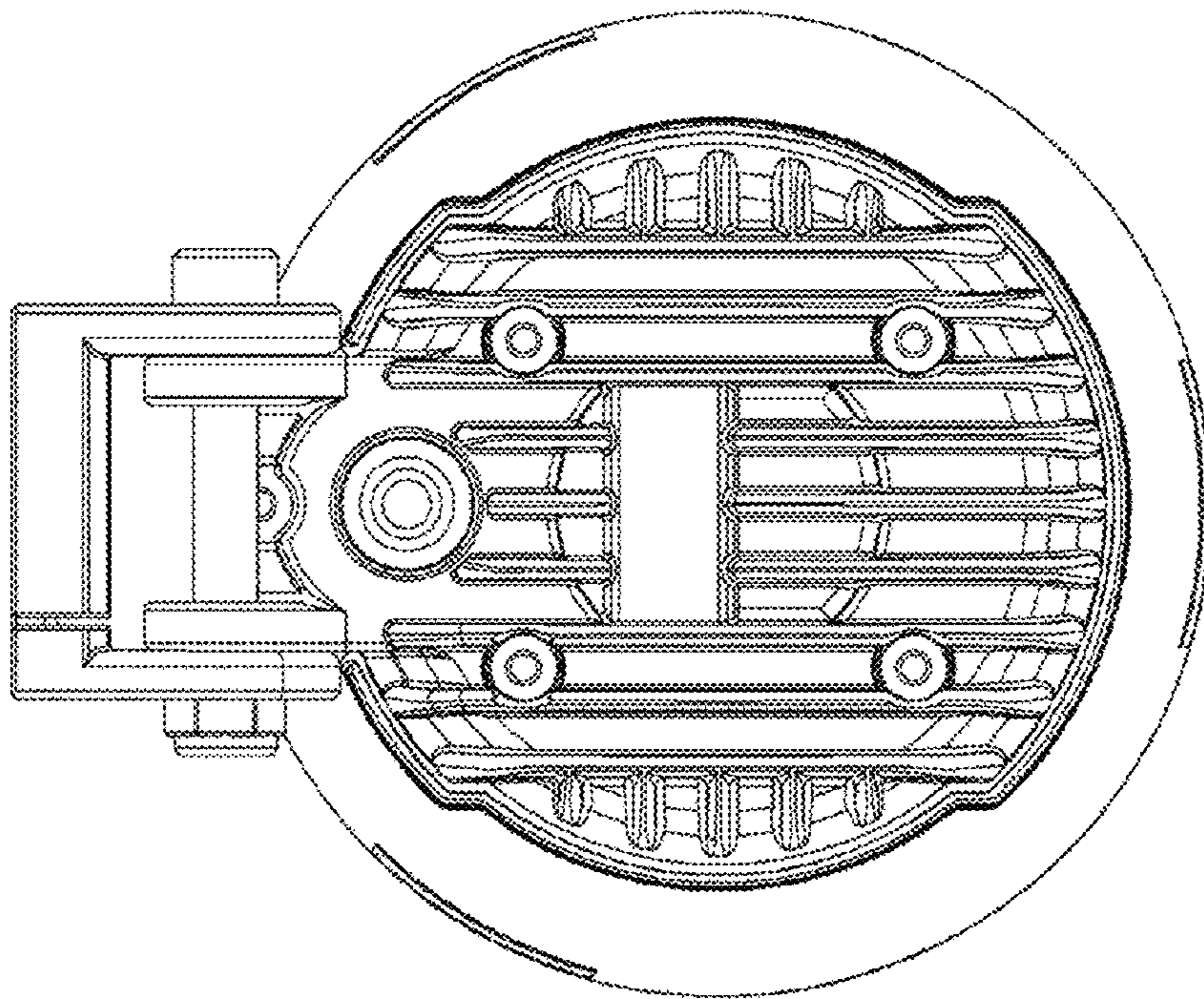

FIG. 7