



US00D735873S

(12) **United States Design Patent**
Brefka et al.

(10) **Patent No.:** **US D735,873 S**

(45) **Date of Patent:** **** Aug. 4, 2015**

(54) **TRANSCUTANEOUS ELECTRICAL NERVE STIMULATION (TENS) DEVICE**

(71) Applicant: **NeuroMetrix, Inc.**, Waltham, MA (US)

(72) Inventors: **Paul E. Brefka**, Southborough, MA (US); **Marc Cryan**, Maynard, MA (US); **Shai N. Gozani**, Brookline, MA (US); **Michael L. Williams**, Melrose, MA (US)

(73) Assignee: **NeuroMetrix, Inc.**, Waltham, MA (US)

(**) Term: **14 Years**

(21) Appl. No.: **29/480,468**

(22) Filed: **Jan. 27, 2014**

(51) **LOC (10) Cl.** **24-01**

(52) **U.S. Cl.**
USPC **D24/200**

(58) **Field of Classification Search**
USPC D2/627, 629, 633; D10/31, 32;
D24/158, 165, 167, 170, 184, 186, 187,
D24/188, 189, 190, 191, 192, 200, 211,
D24/214; 600/500, 503; 607/46, 115
CPC A61N 1/04; A61N 1/08; A61N 1/0456;
A61N 1/36021
See application file for complete search history.

(56) **References Cited**

U.S. PATENT DOCUMENTS

D251,829 S * 5/1979 Sulek D10/32
D342,571 S * 12/1993 Givens, Sr. D24/186

(Continued)

OTHER PUBLICATIONS

DiaTribe. FDA Approves Sensus Pain Management Device For Over-The-Counter Use. Jul. 20, 2014 [online], [site visited Mar. 4, 2015]. Available from Internet, <URL:http://diatribe.org/issues/66/new-now-next/5>.*

(Continued)

Primary Examiner — Robert M Spear

Assistant Examiner — Darcey E Heflin

(74) *Attorney, Agent, or Firm* — Pandiscio & Pandiscio

(57) **CLAIM**

The ornamental design for a transcutaneous electrical nerve stimulation (TENS) device, as shown and described.

DESCRIPTION

FIG. 1 is a top right perspective view of the transcutaneous electrical nerve stimulation (TENS) device;
FIG. 2 is a top left perspective view of the transcutaneous electrical nerve stimulation (TENS) device;
FIG. 3 is a front perspective view of the transcutaneous electrical nerve stimulation (TENS) device, taken from the frame of reference of FIG. 1;
FIG. 4 is a rear perspective view of the transcutaneous electrical nerve stimulation (TENS) device, taken from the frame of reference of FIG. 1;
FIG. 5 is a right side view, in elevation, of the transcutaneous electrical nerve stimulation (TENS) device, taken from the frame of reference of FIG. 1;
FIG. 6 is a left side view, in elevation, of the transcutaneous electrical nerve stimulation (TENS) device, taken from the frame of reference of FIG. 1;
FIG. 7 is a top view of the transcutaneous electrical nerve stimulation (TENS) device, taken from the frame of reference of FIG. 1;
FIG. 8 is a bottom view of the transcutaneous electrical nerve stimulation (TENS) device, taken from the frame of reference of FIG. 1;
FIG. 9 is a bottom right perspective view of the transcutaneous electrical nerve stimulation (TENS) device; and,
FIG. 10 is a bottom left perspective view of the transcutaneous electrical nerve stimulation (TENS) device.

1 Claim, 10 Drawing Sheets

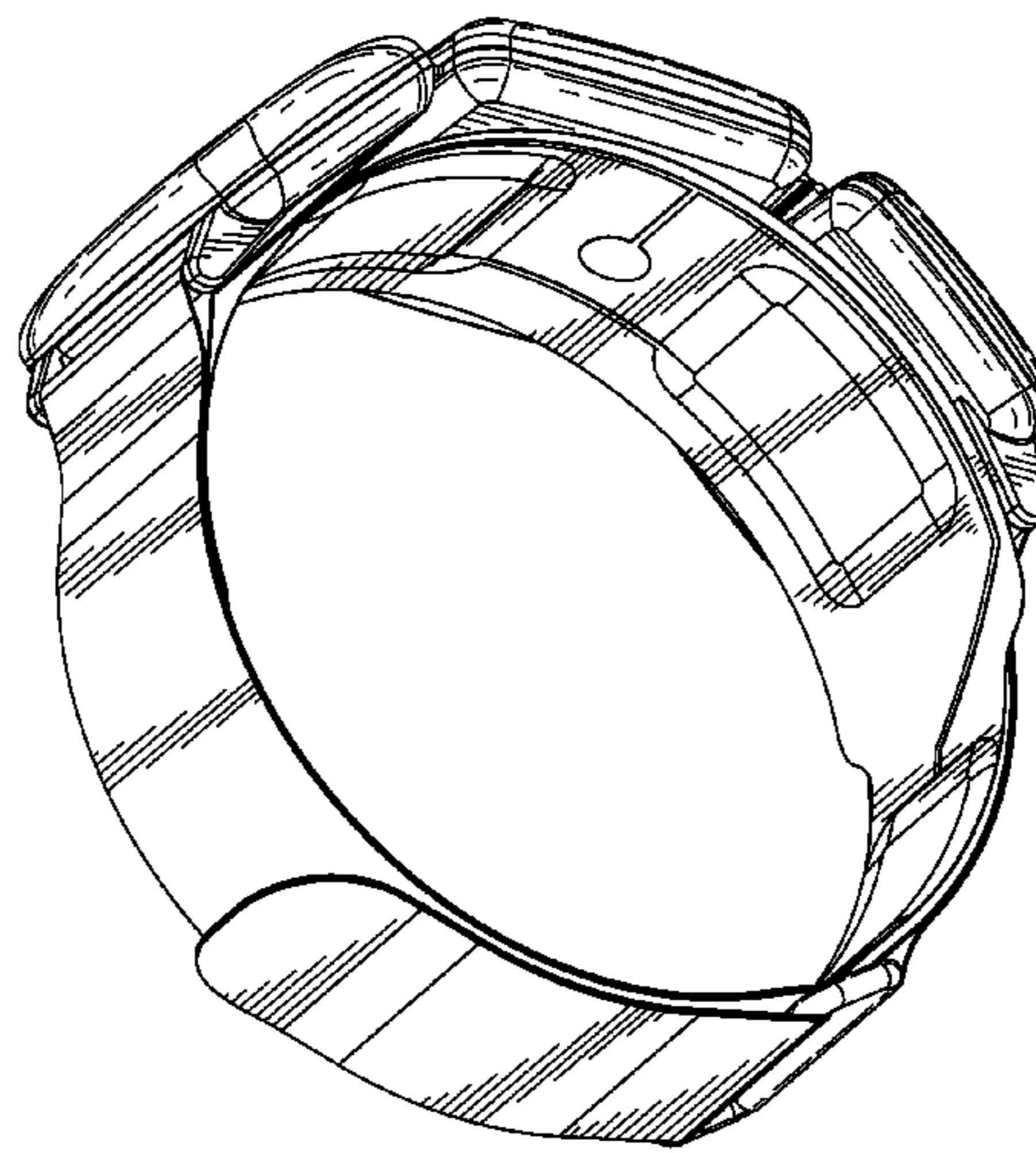
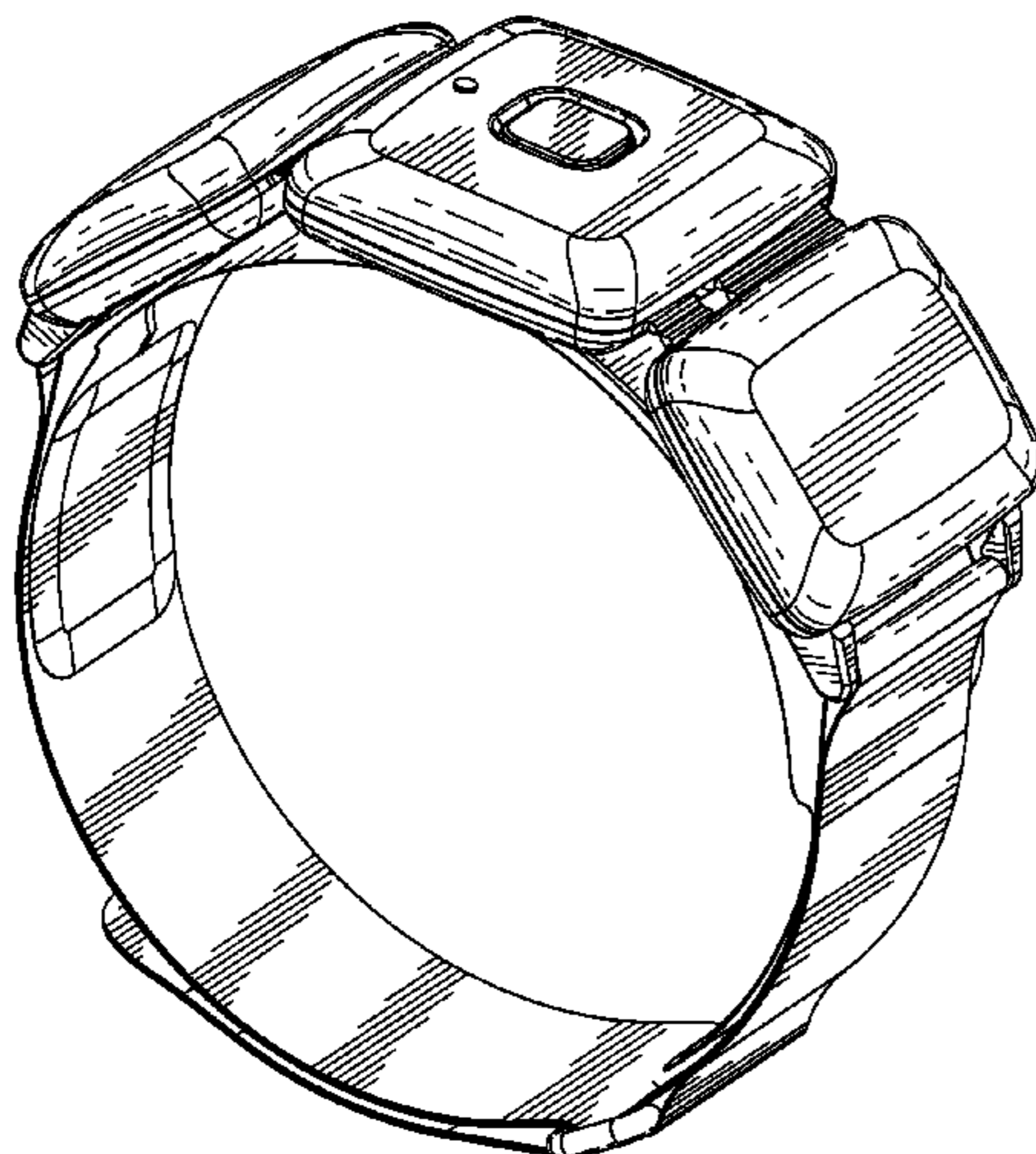

(56)

References Cited

OTHER PUBLICATIONS

U.S. PATENT DOCUMENTS

D422,709	S *	4/2000	Caswell	D24/190
D595,858	S *	7/2009	Kazel	D24/186
D597,676	S *	8/2009	Copeland et al.	D24/187
D622,031	S *	8/2010	Wyszynski	D2/627
D711,002	S *	8/2014	Ohnemus et al.	D24/186
D716,457	S *	10/2014	Brefka et al.	D24/186
D716,458	S *	10/2014	Snyder et al.	D24/186
8,915,859	B1 *	12/2014	Rulkov et al.	600/500
2013/0158627	A1 *	6/2013	Gozani et al.	607/46
2014/0296934	A1 *	10/2014	Gozani et al.	607/46
2014/0309709	A1 *	10/2014	Gozani et al.	607/46

Med Gadget. NeuroMetrix Pain Management Technology Cleared for OTC Use by FDA. Jul. 9, 2014 [online], [site visited Mar. 4, 2015]. Available from Internet, <URL:<http://www.medgadget.com/2014/07/sensus-peripheral-neuropathy-pain-management-system-cleared-for-otc-use-by-fda.html>>.*

YouTube. Sensus Pain Management System 3 Simple Steps. Feb. 8, 2013 [online], [site visited Mar. 4, 2015]. Available from Internet, <URL:<https://www.youtube.com/watch?v=IFAgNSaUYsk>>.*

* cited by examiner

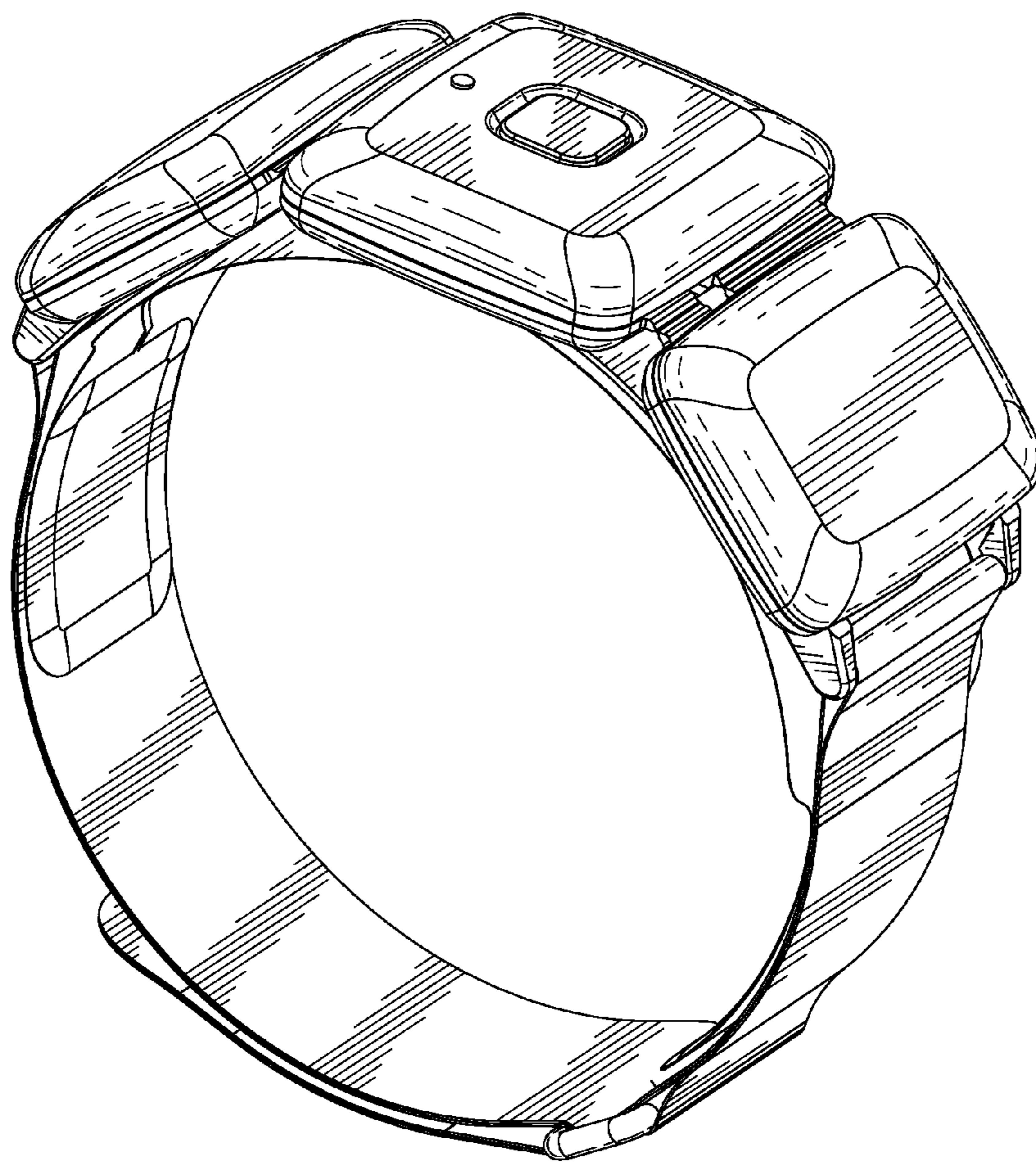

FIG. 1

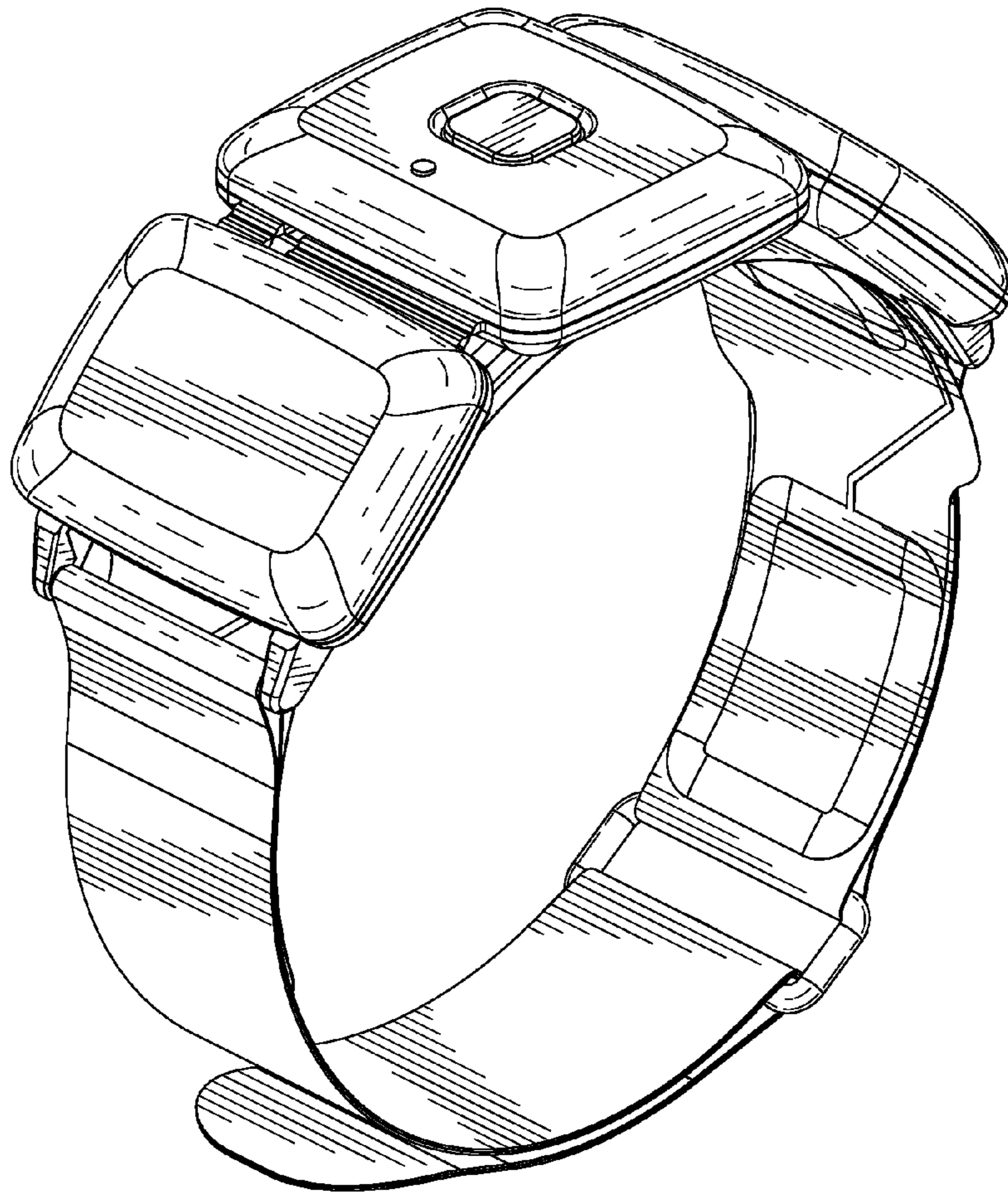

FIG. 2

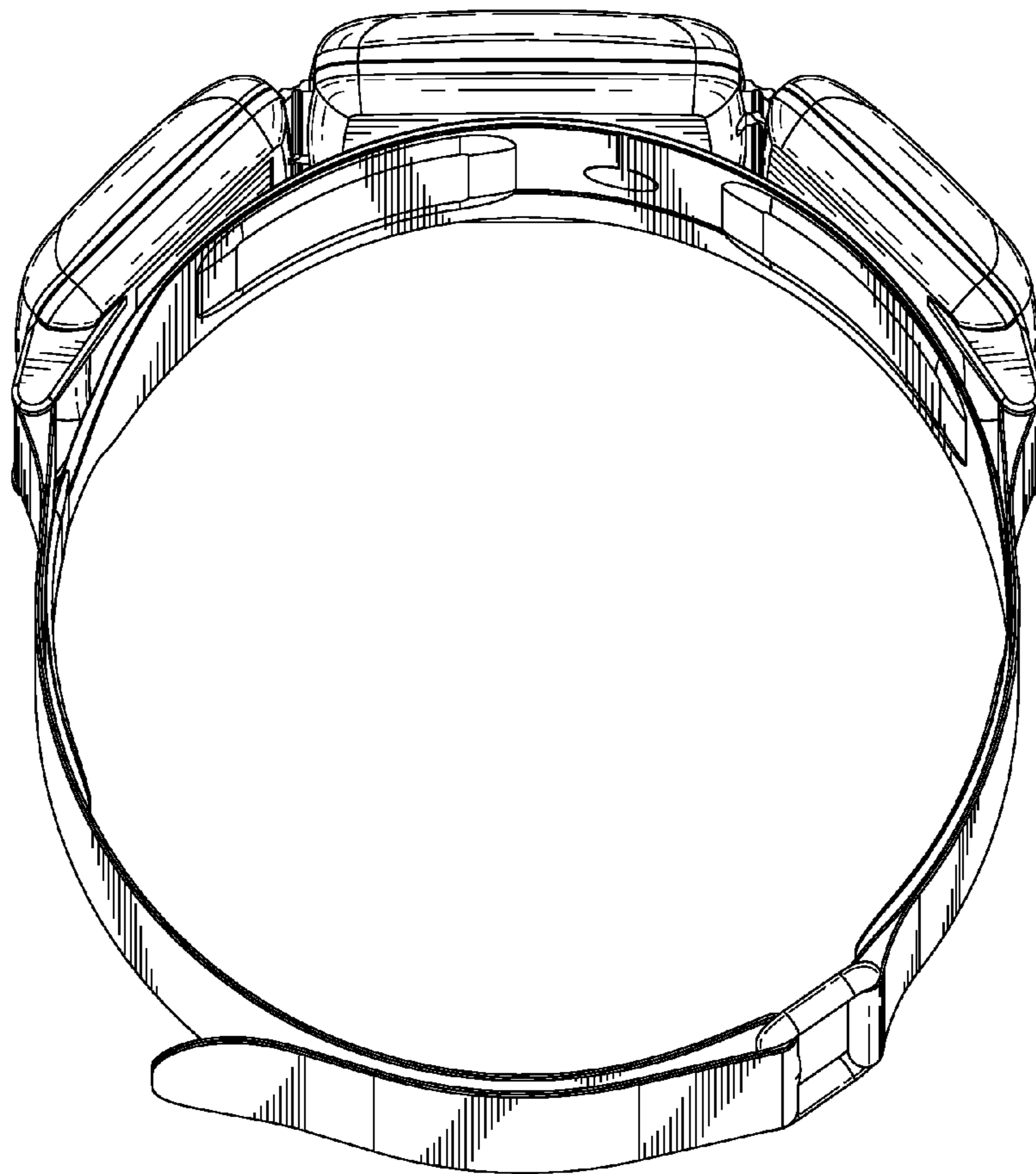

FIG. 3

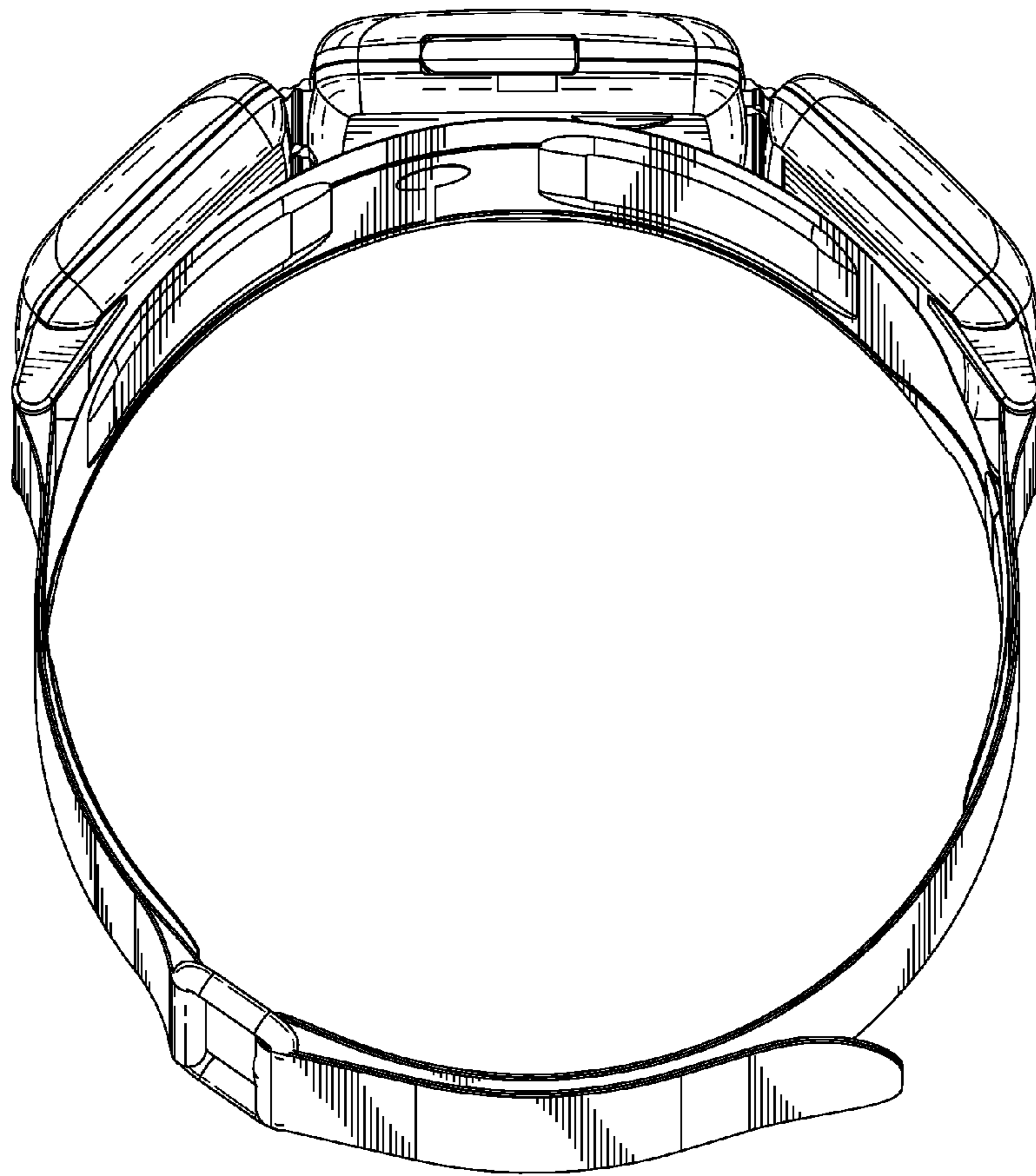

FIG. 4

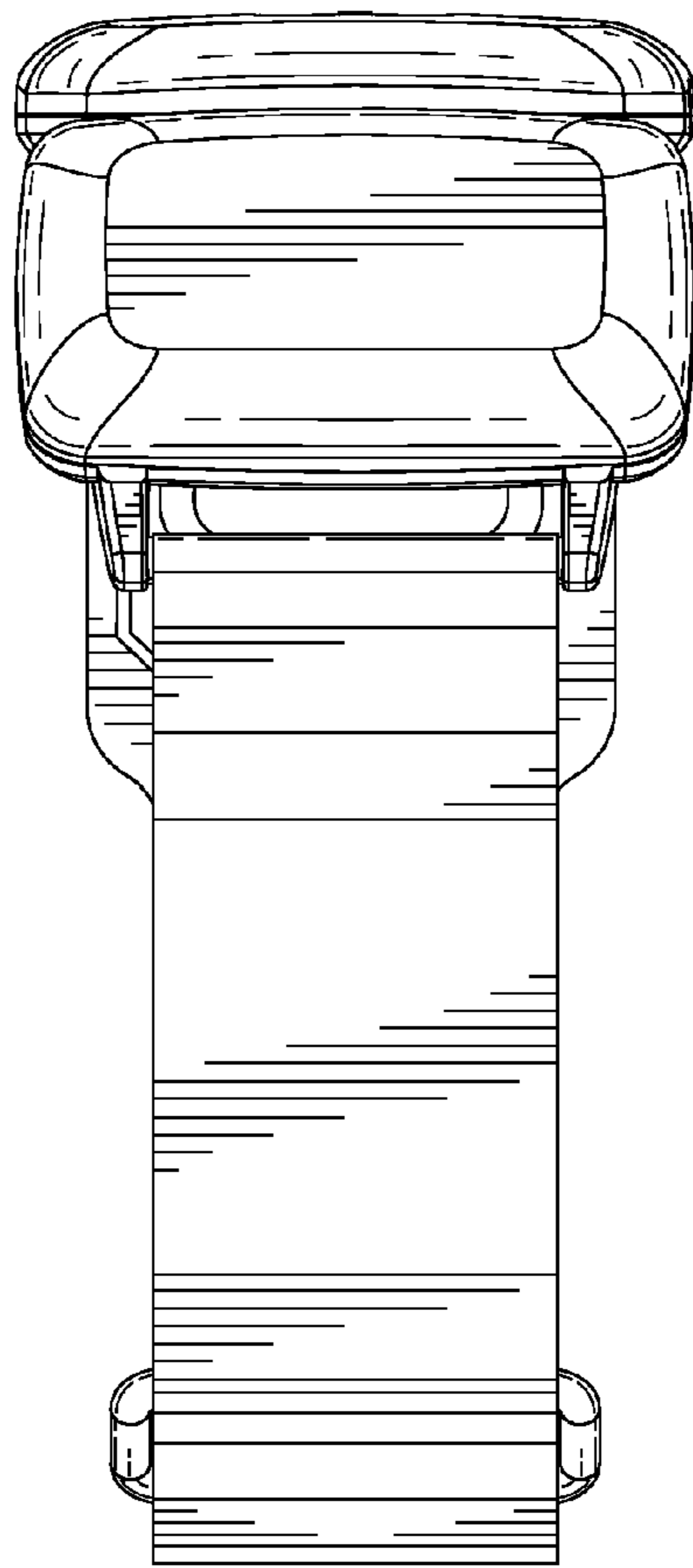

FIG. 5

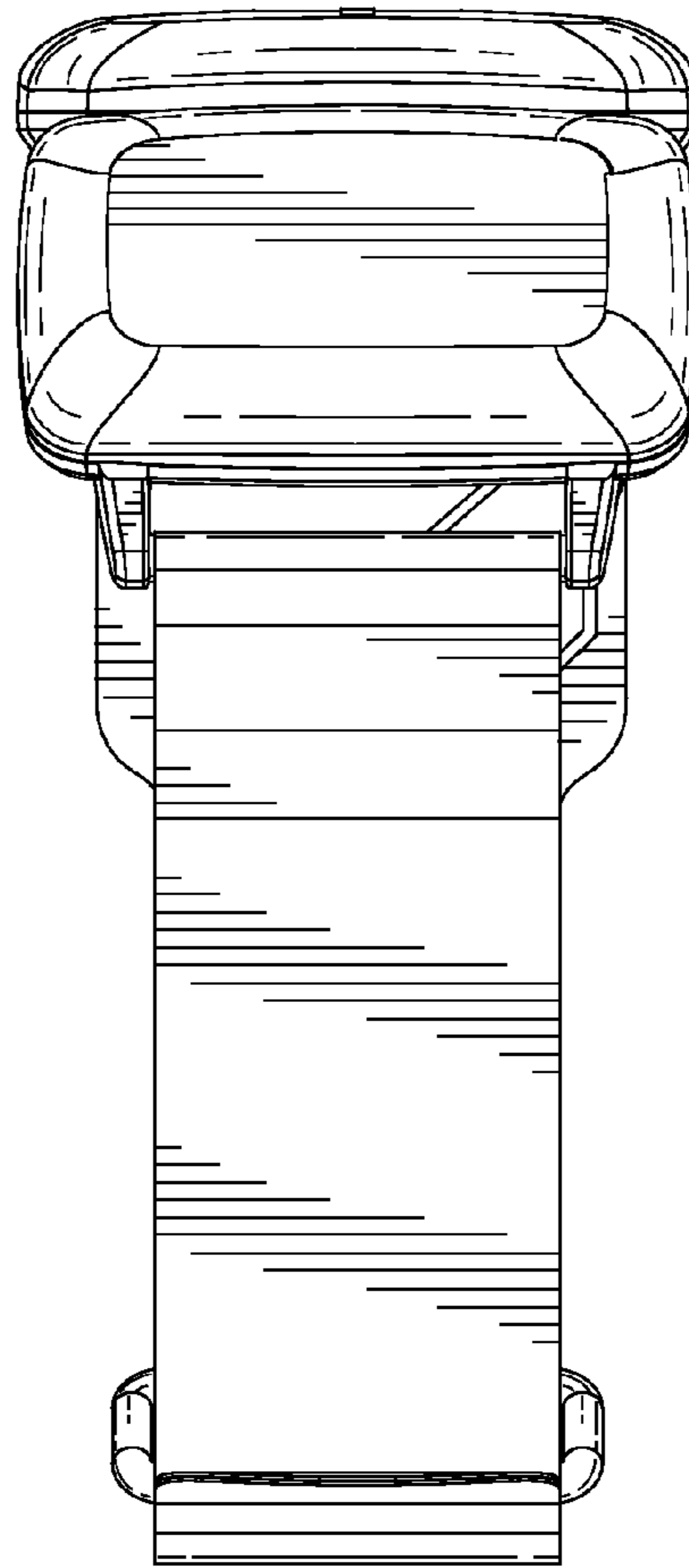

FIG. 6

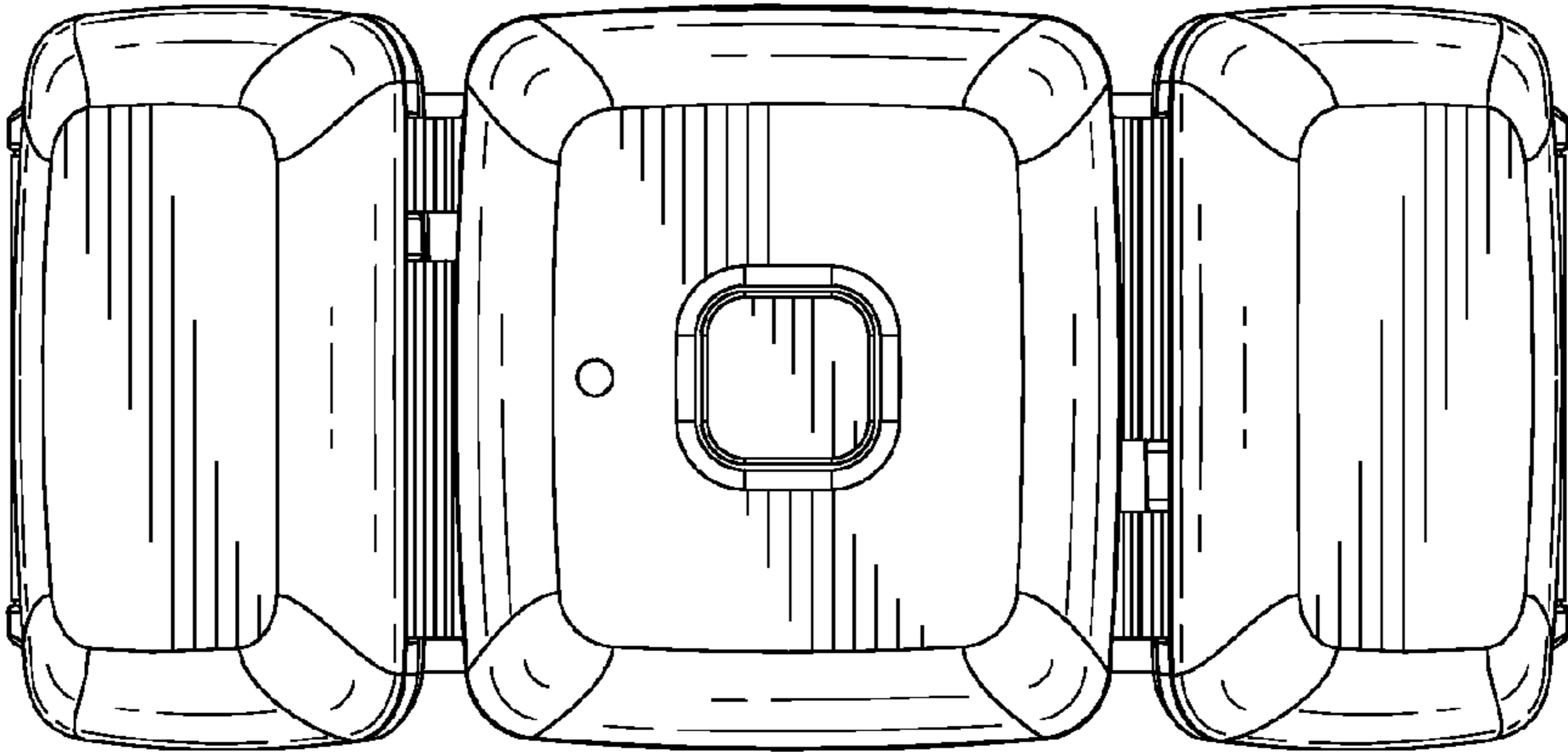

FIG. 7

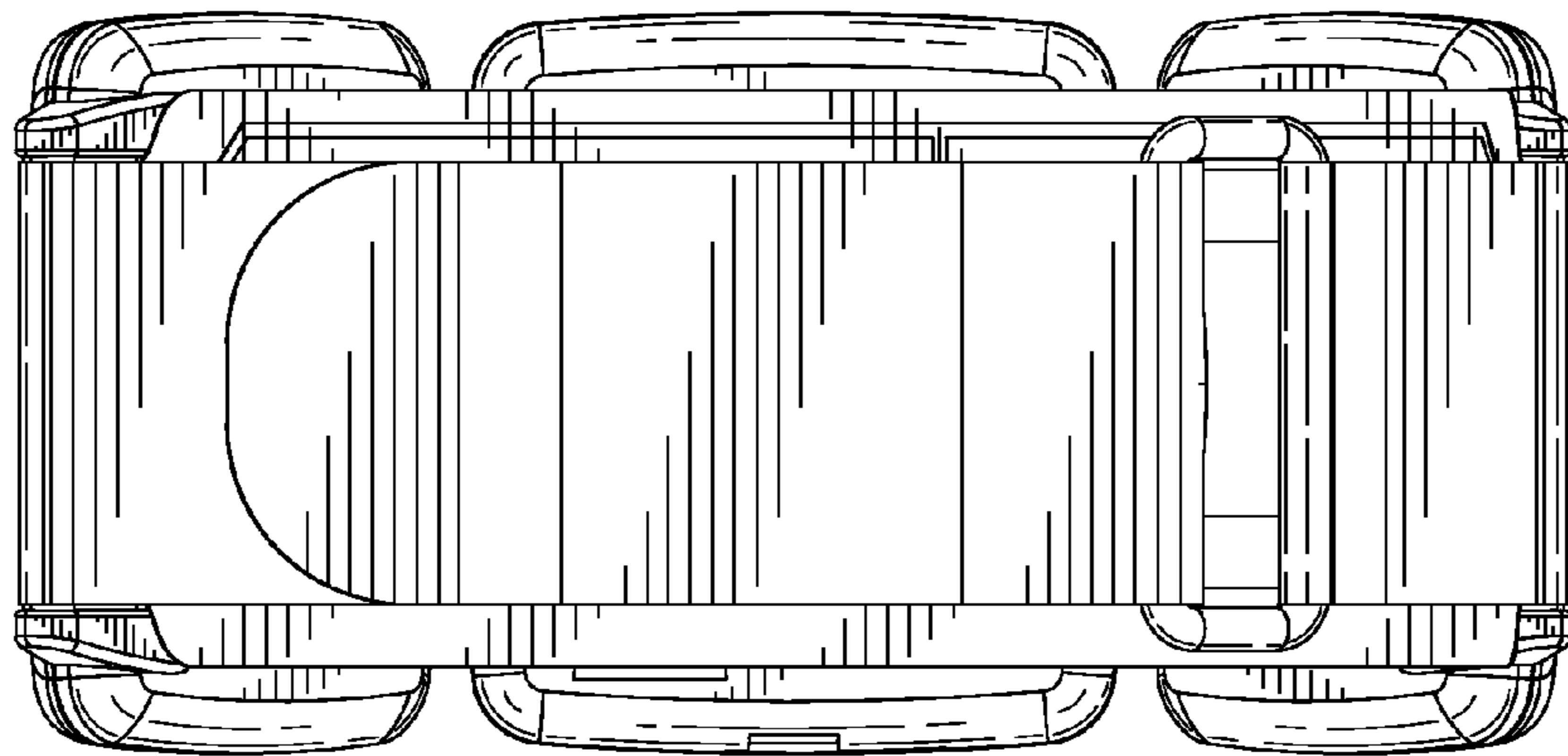

FIG. 8

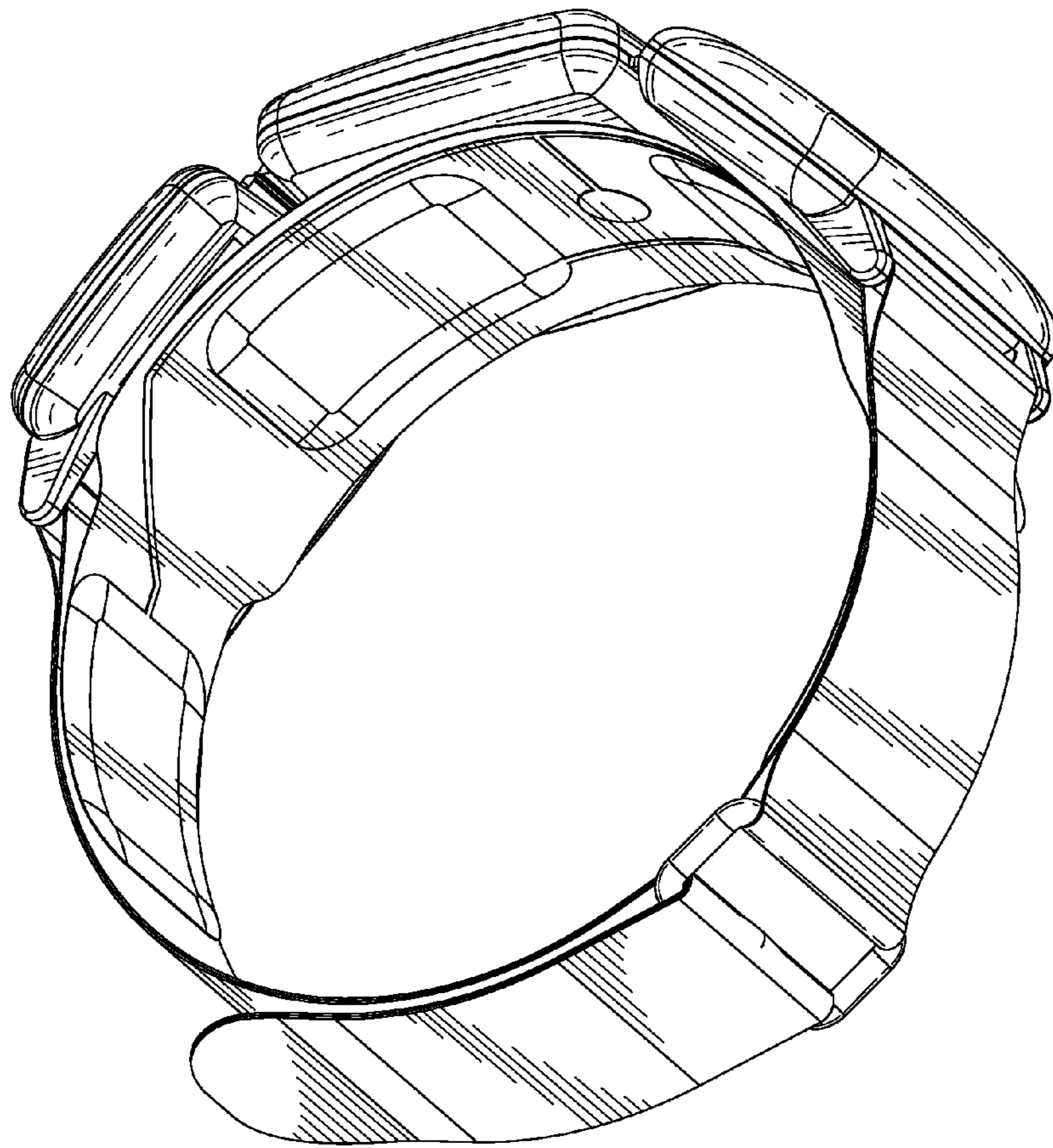

FIG. 9

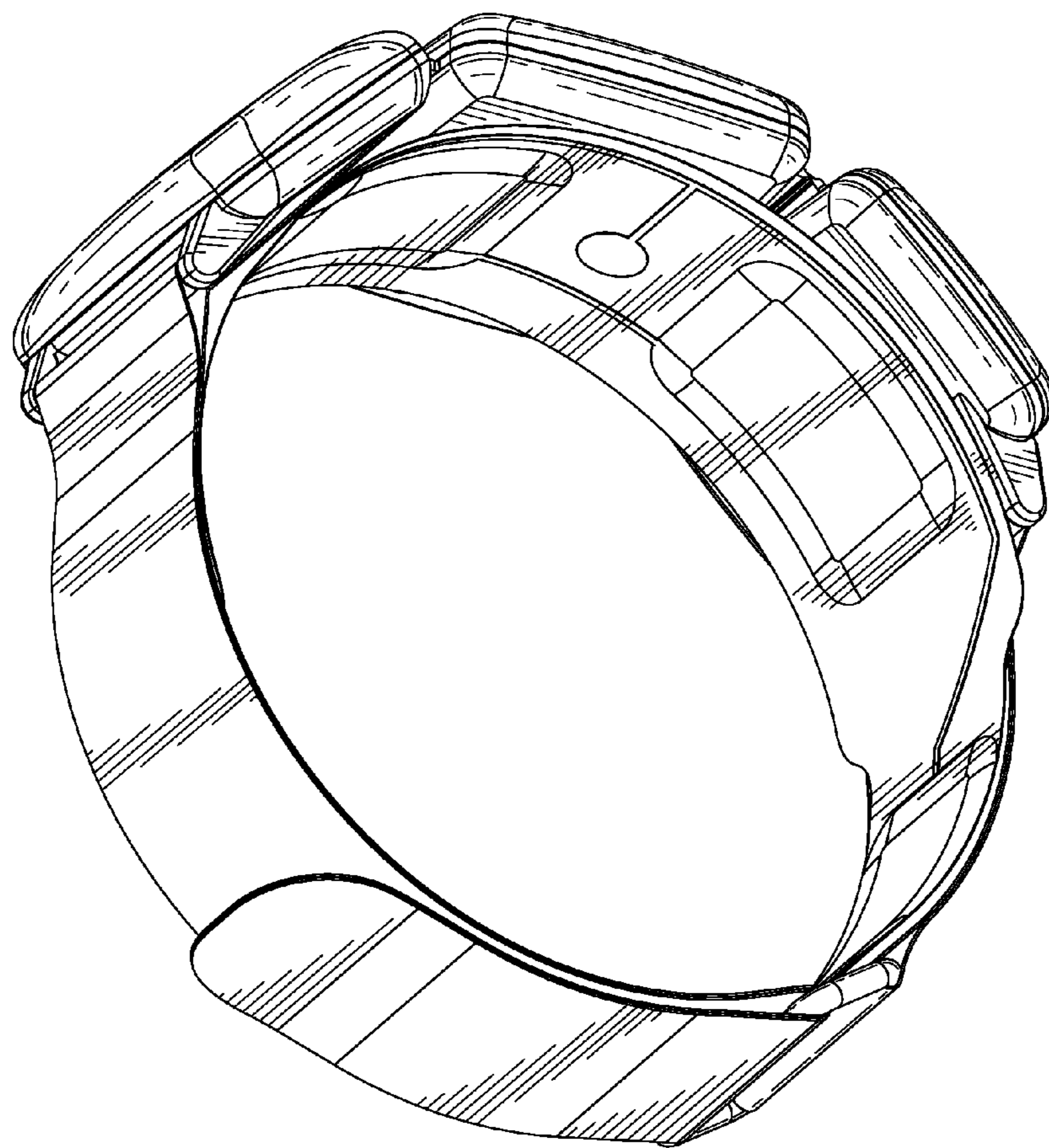

FIG. 10