



US00D735785S

(12) **United States Design Patent**
O'Malley

(10) **Patent No.:** **US D735,785 S**

(45) **Date of Patent:** **** Aug. 4, 2015**

(54) **MILL TOOL**

(71) Applicant: **ELEMENT SIX LIMITED**, County Clare (IE)

(72) Inventor: **Dermot Francis O'Malley**, Shannon (IE)

(73) Assignee: **Element Six Limited**, County Clare (IE)

(**) Term: **14 Years**

(21) Appl. No.: **29/480,831**

(22) Filed: **Jan. 30, 2014**

Related U.S. Application Data

(62) Division of application No. 29/473,995, filed on Nov. 27, 2013.

(30) **Foreign Application Priority Data**

Jul. 19, 2013	(GB)	1312954.9
Nov. 27, 2013	(EM)	002352872-0001
Nov. 27, 2013	(EM)	002352872-0002
Nov. 27, 2013	(EM)	002352872-0003

(51) **LOC (10) Cl.** **15-09**

(52) **U.S. Cl.**
USPC **D15/131; D15/139**

(58) **Field of Classification Search**
USPC D15/128, 131, 138, 139, 140
See application file for complete search history.

(56) **References Cited**

U.S. PATENT DOCUMENTS

1,591,967	A *	7/1926	Emerson	451/474
1,603,739	A *	10/1926	Borgeson	408/229
1,747,713	A *	2/1930	Havlista	407/42

3,451,721	A *	6/1969	Speirs et al.	299/39.8
4,844,666	A *	7/1989	Tsujimura et al.	407/34
5,074,356	A *	12/1991	Neff	166/55.7
D682,898	S *	5/2013	Fujii	D15/139
8,499,834	B2 *	8/2013	Guidry et al.	166/298
8,702,352	B2 *	4/2014	Sjoo	407/40
D706,844	S *	6/2014	Qiu et al.	D15/139
8,820,848	B2 *	9/2014	Rotsch et al.	299/39.4
8,974,155	B2 *	3/2015	Dressler	407/59

OTHER PUBLICATIONS

U.S. Appl. No. 29/473,995, Notice of Allowance mailed May 13, 2015, 12 pages.

U.S. Appl. No. 29/480,832, Notice of Allowance mailed May 13, 2015, 11 pages.

* cited by examiner

Primary Examiner — Patricia Palasik

(74) *Attorney, Agent, or Firm* — Dean W. Russell; Michael A. Bertelson; Kilpatrick Townsend & Stockton LLP

(57) **CLAIM**

The ornamental design for a mill tool, as shown and described.

DESCRIPTION

FIG. 1 is a front elevational view of a mill tool showing my new design;
FIG. 2 is a top elevational view thereof;
FIG. 3 is a perspective view thereof;
FIG. 4 is a second perspective view thereof; and,
FIG. 5 is a back elevational view thereof.
The broken lines illustrate environmental structures and boundaries of the claimed design, and form no part of the claimed design.

1 Claim, 4 Drawing Sheets

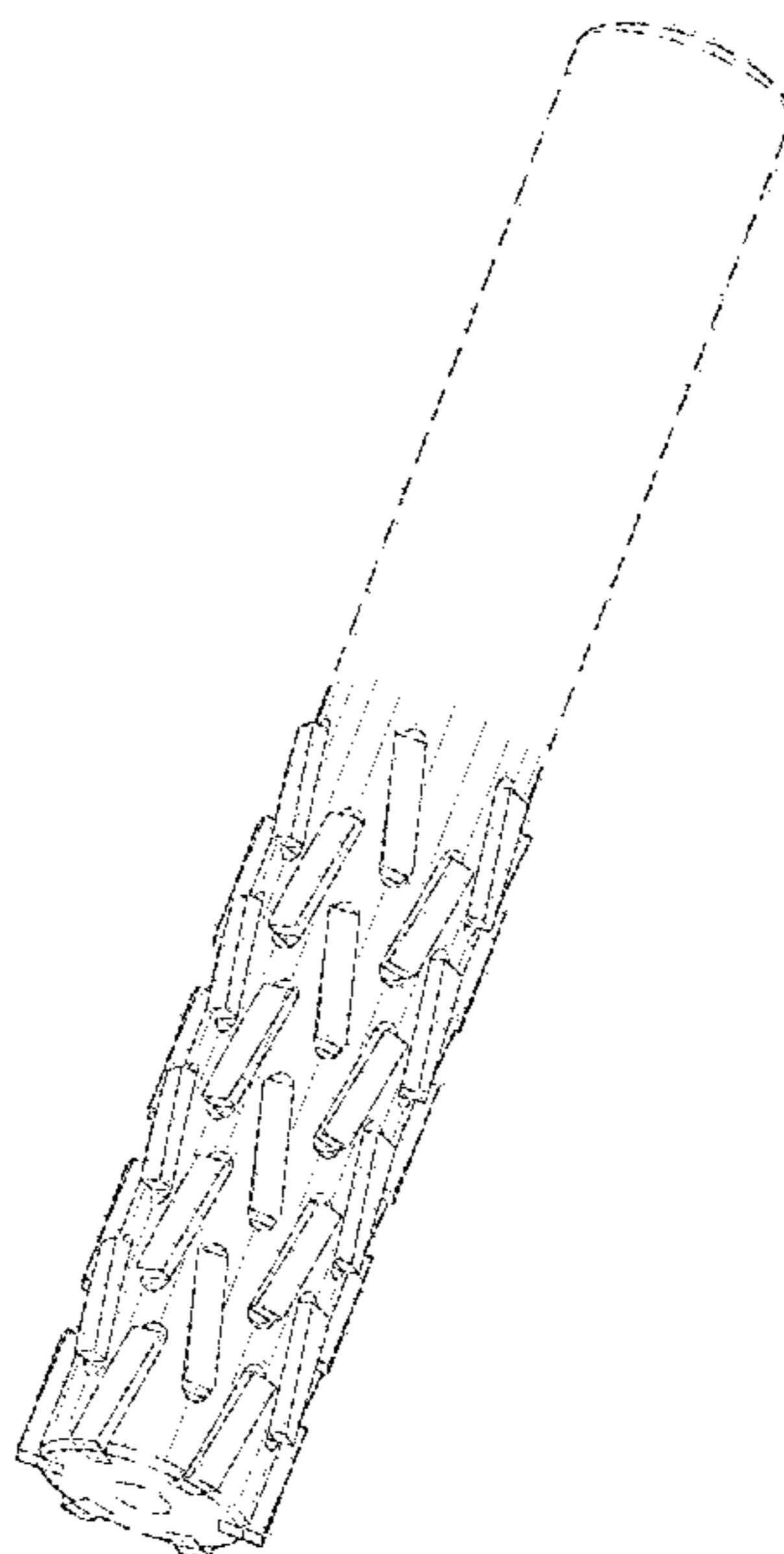

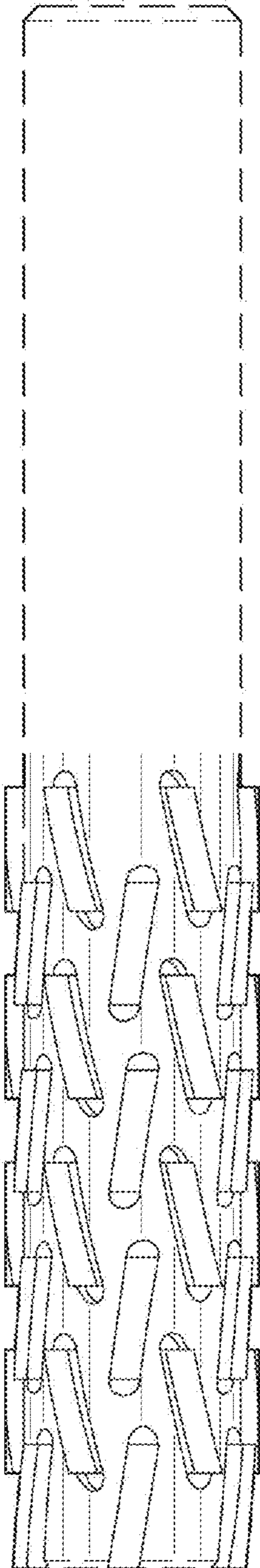

FIG. 1

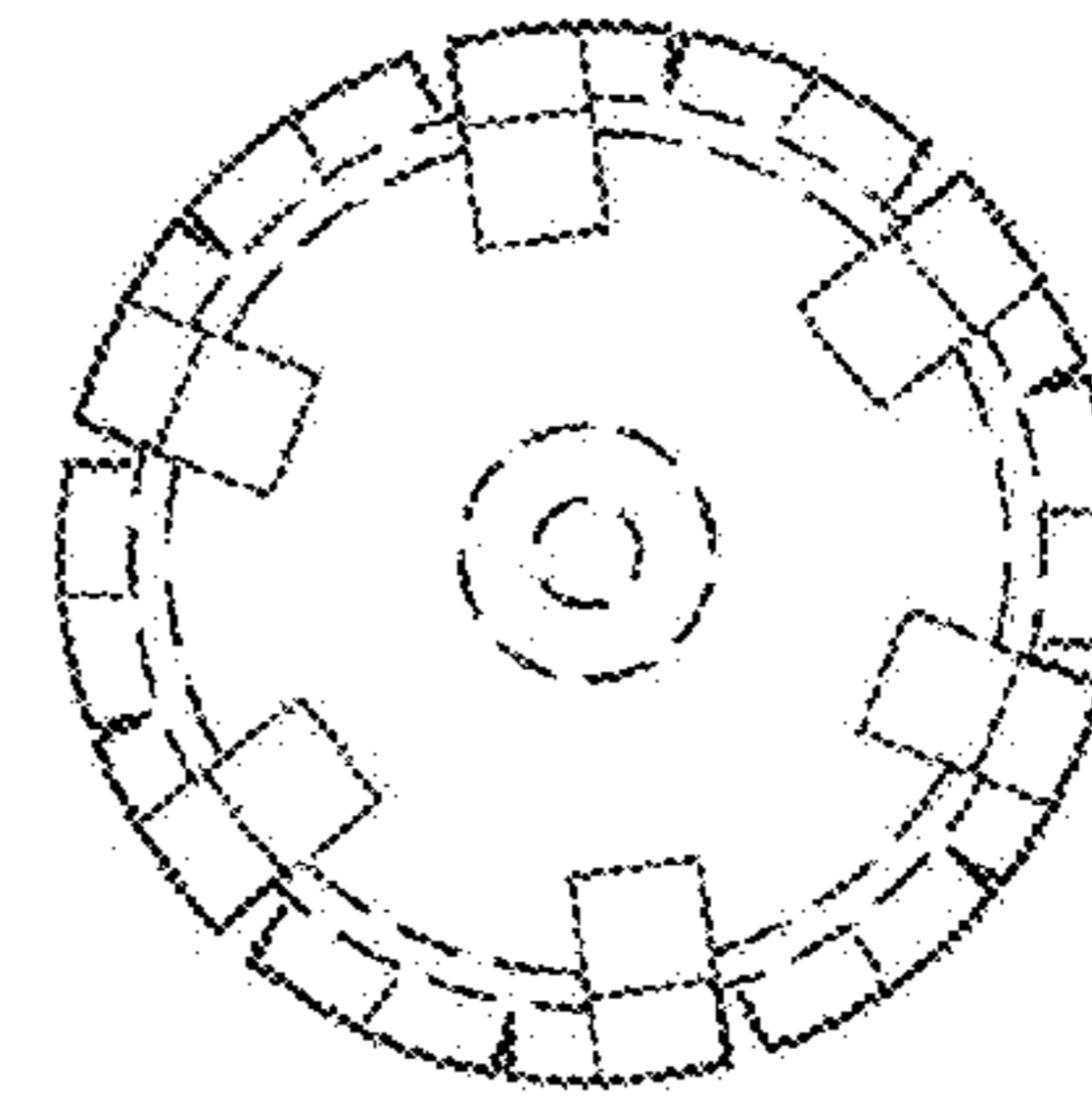

FIG. 2

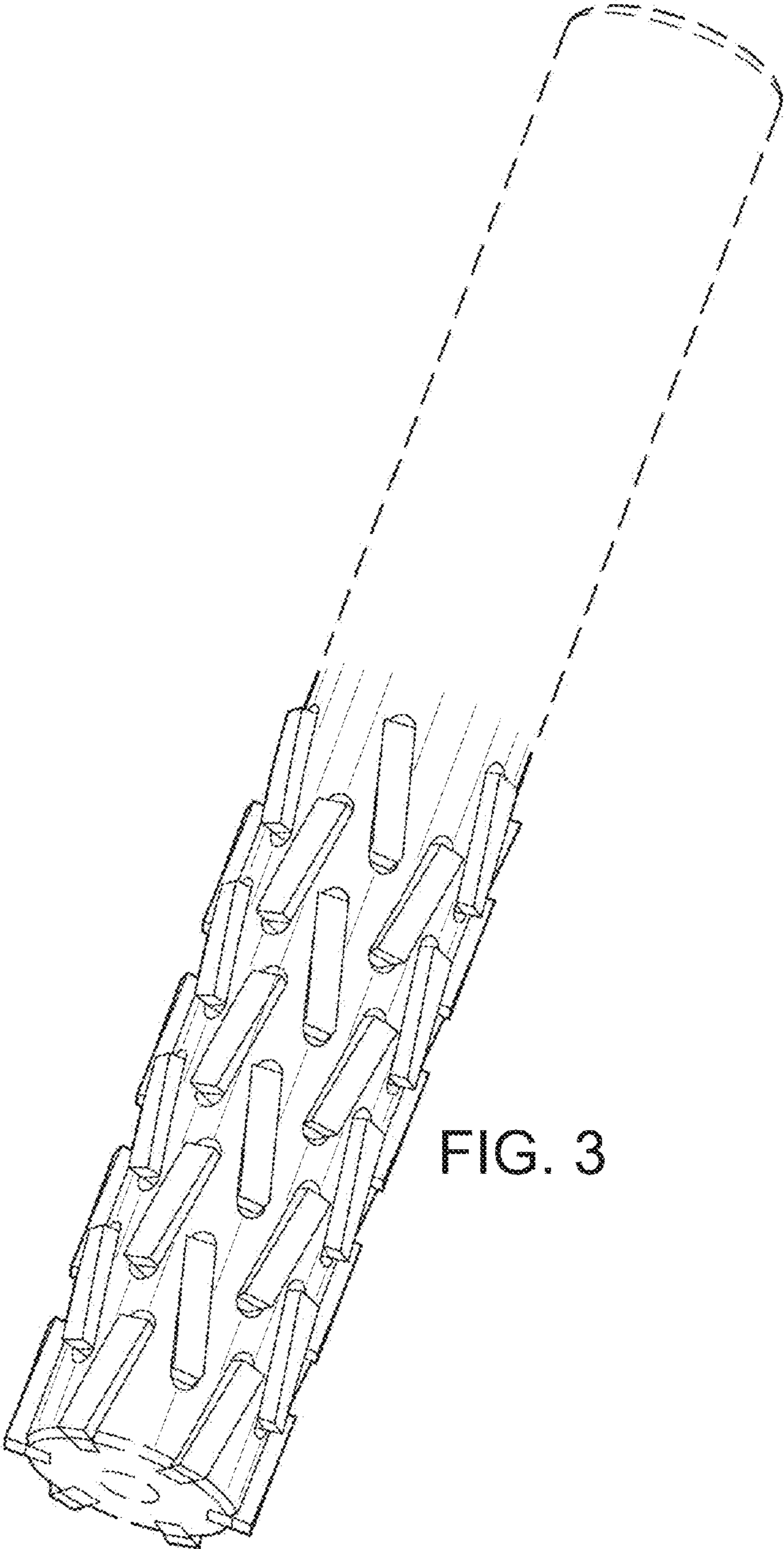

FIG. 3

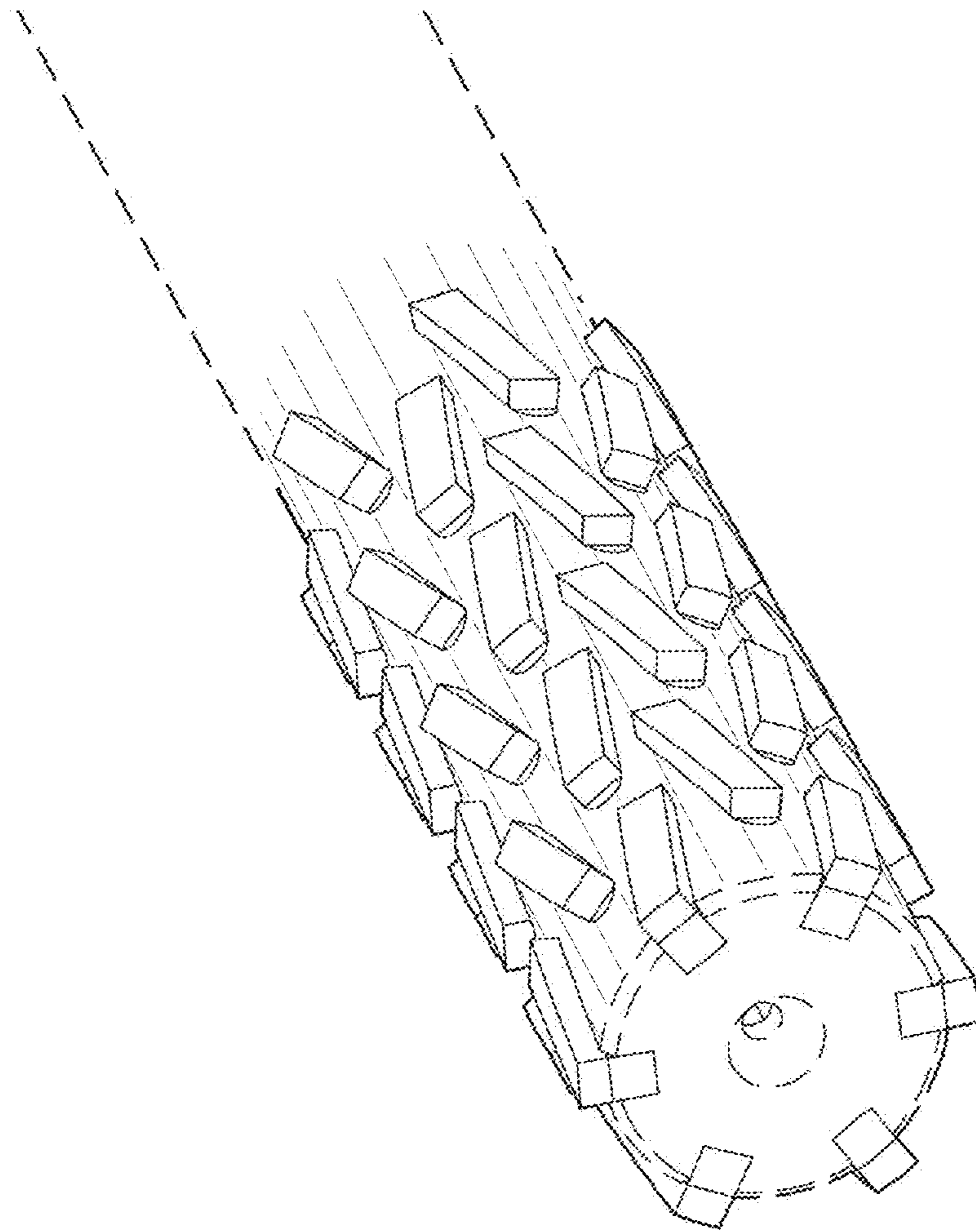

FIG. 4

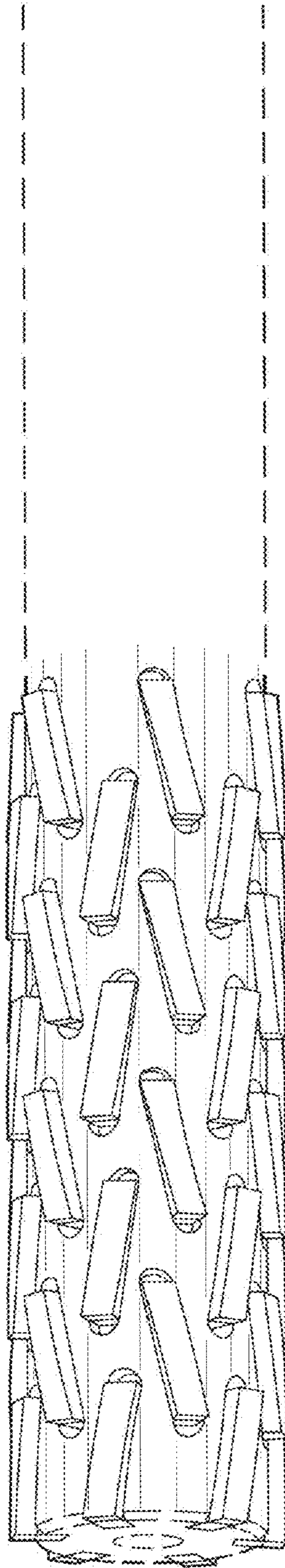

FIG. 5