



US00D735635S

(12) **United States Design Patent**
Sonnentag et al.

(10) **Patent No.:** **US D735,635 S**

(45) **Date of Patent:** **** Aug. 4, 2015**

(54) **LUGGAGE RACK**

(71) Applicant: **Harley-Davidson Motor Company Group, LLC**, Milwaukee, WI (US)

(72) Inventors: **Jeffary Ronald Sonnentag**, Waukesha, WI (US); **Mark G. Daniels**, Mequon, WI (US); **Matthew John Van Dyke**, West Allis, WI (US); **Chetan Suhas Shedjale**, Wauwatosa, WI (US); **Steve Clark Zenge**, Glendale, WI (US)

(73) Assignee: **Harley-Davidson Motor Company Group, LLC**, Milwaukee, WI (US)

(**) Term: **14 Years**

(21) Appl. No.: **29/494,815**

(22) Filed: **Jun. 24, 2014**

(51) **LOC (10) Cl.** **12-11**

(52) **U.S. Cl.**
USPC **D12/407**

(58) **Field of Classification Search**

USPC D12/115, 120, 407, 412, 413, 414, D12/414.1; D3/304-306; D6/552; 211/5, 211/17-22; 224/309-310, 315-316, 319, 224/323-329, 400, 331, 321, 229.1, 316.4, 224/924, 299.1; 248/176.1, 309.1; 280/293, 280/760-762, 848, 727, 769; 293/3, 100
CPC B62J 7/00; B62J 7/02; B62J 7/04; B62J 7/08

See application file for complete search history.

(56) **References Cited**

U.S. PATENT DOCUMENTS

D208,895	S	*	10/1967	Lahti	D12/407
D244,928	S	*	7/1977	Oakes	D12/407
D255,561	S	*	6/1980	Pold et al.	D12/407
D276,330	S	*	11/1984	Stahel	D12/407
D364,140	S	*	11/1995	Gustavsen	D12/407
D374,422	S	*	10/1996	Gogan et al.	D12/407
D392,247	S	*	3/1998	Gogan et al.	D12/407
D395,420	S	*	6/1998	Gogan et al.	D12/407
D427,963	S	*	7/2000	Gogan et al.	D12/407
D428,848	S	*	8/2000	Wurst	D12/407
D575,722	S	*	8/2008	Beauchamp et al.	D12/412
D719,904	S	*	12/2014	Rickard	D12/412
2003/0010556	A1	*	1/2003	Galbraith et al.	180/219

* cited by examiner

Primary Examiner — Philip S Hyder

Assistant Examiner — Darlington Ly

(74) *Attorney, Agent, or Firm* — Michael Best & Friedrich LLP

(57) **CLAIM**

We claim the ornamental design for a luggage rack, as shown and described.

DESCRIPTION

FIG. 1 is a front perspective view of a luggage rack according to a first embodiment of the present invention.

FIG. 2 is a bottom view of the luggage rack of FIG. 1.

FIG. 3 is a top view of the luggage rack of FIG. 1.

FIG. 4 is a right-side view of the luggage rack of FIG. 1.

FIG. 5 is a left-side view of the luggage rack of FIG. 1.

FIG. 6 is a rear view of the luggage rack of FIG. 1; and,

FIG. 7 is a front view of the luggage rack of FIG. 1.

1 Claim, 7 Drawing Sheets

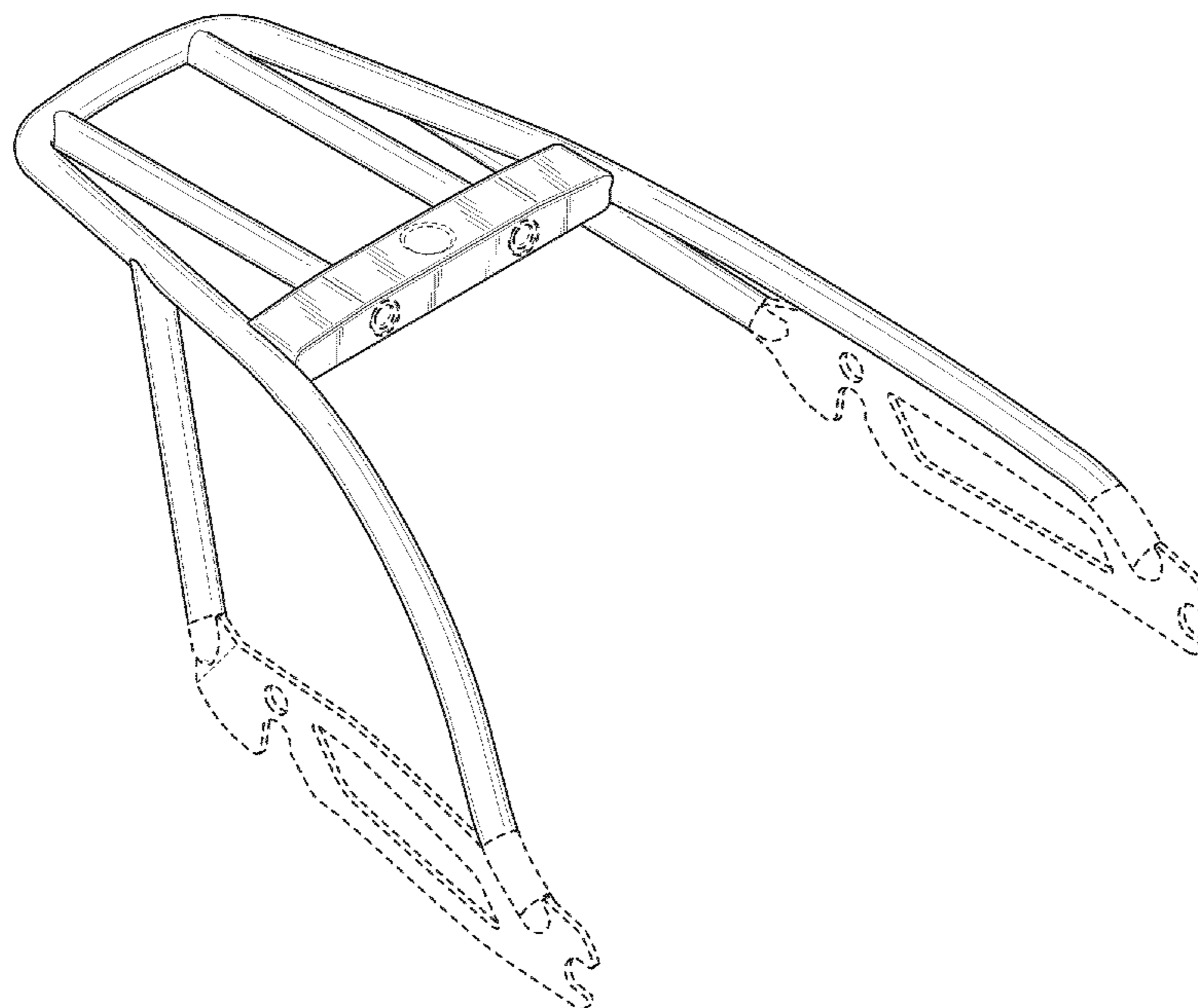

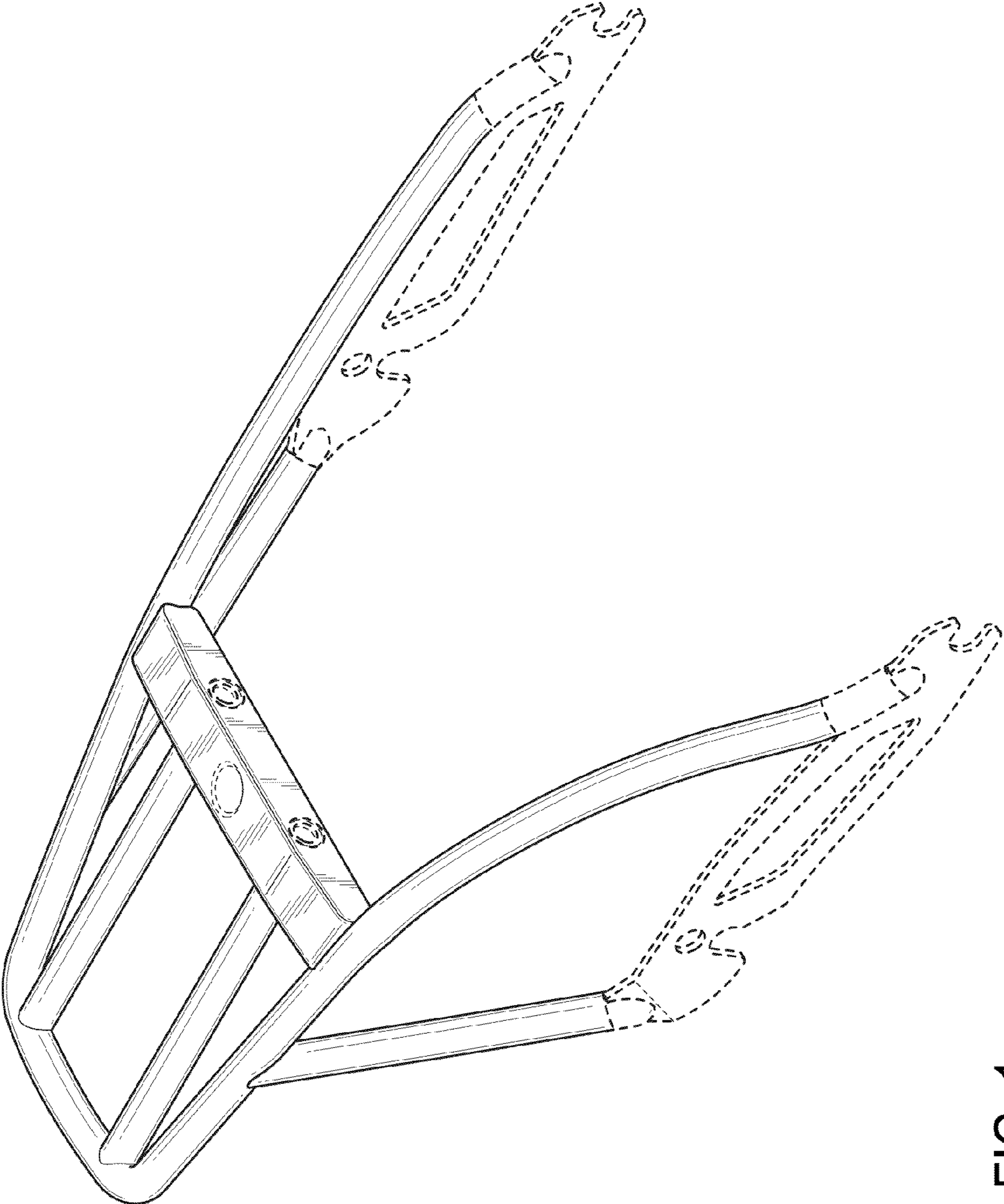

FIG. 1

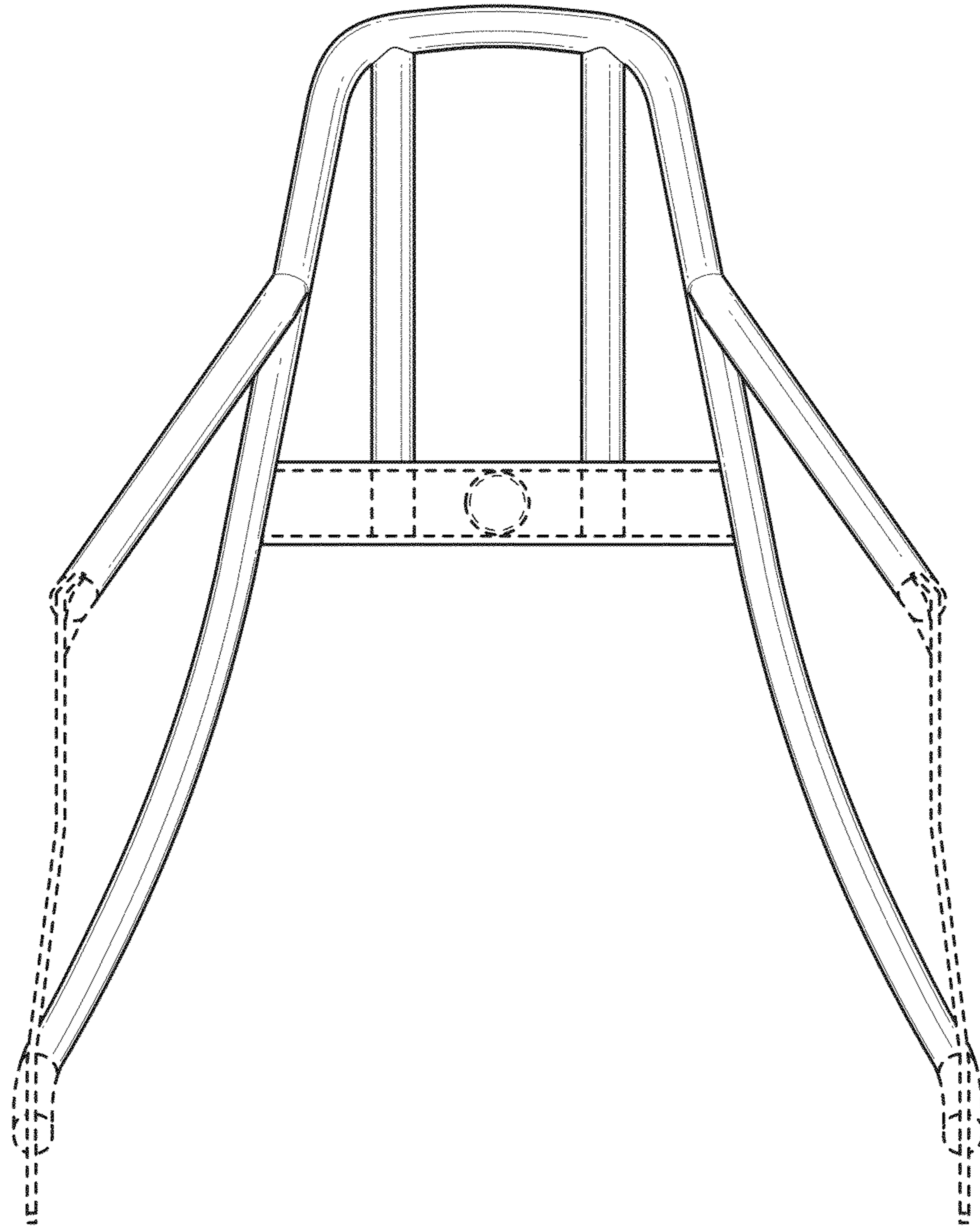

FIG. 2

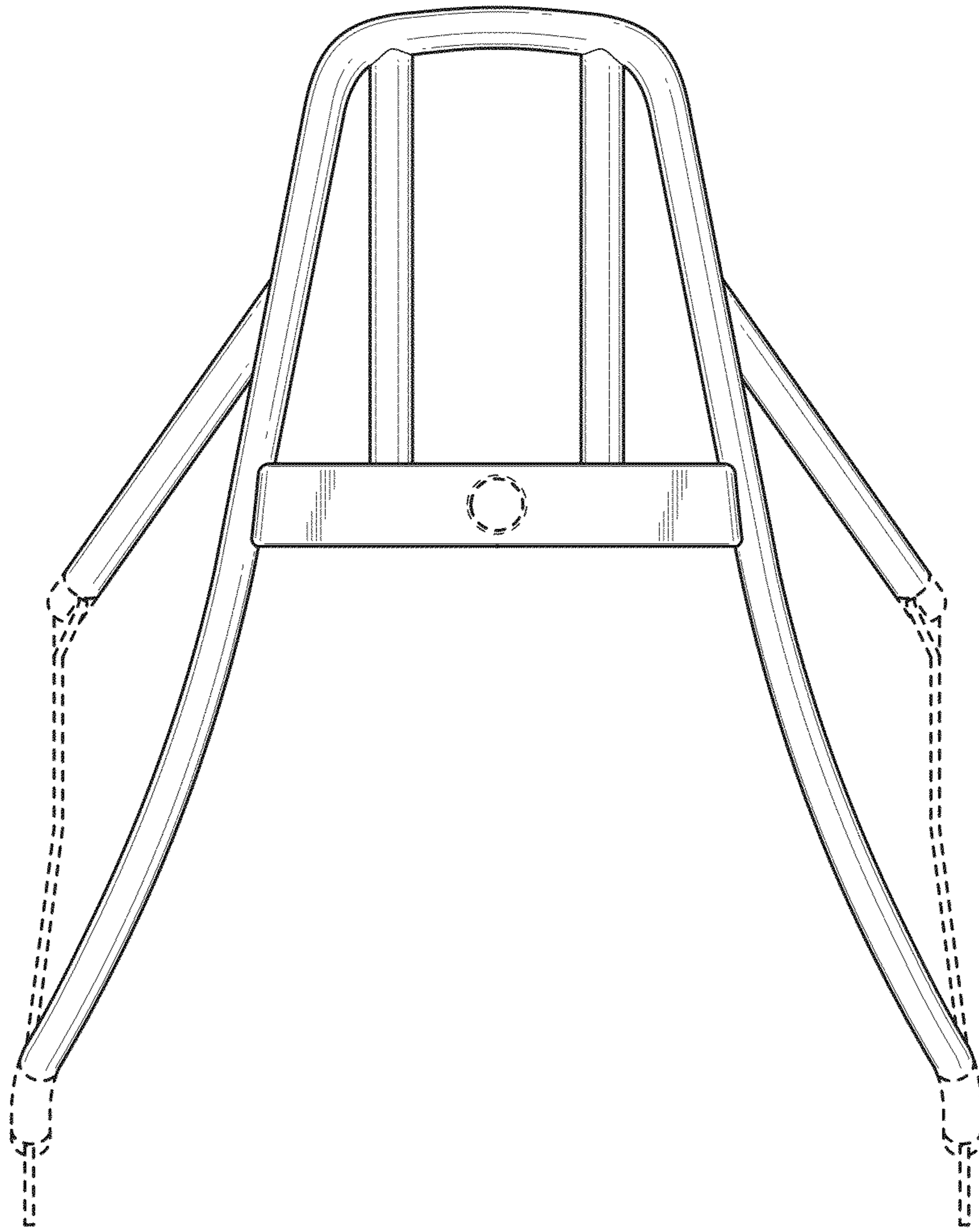

FIG. 3

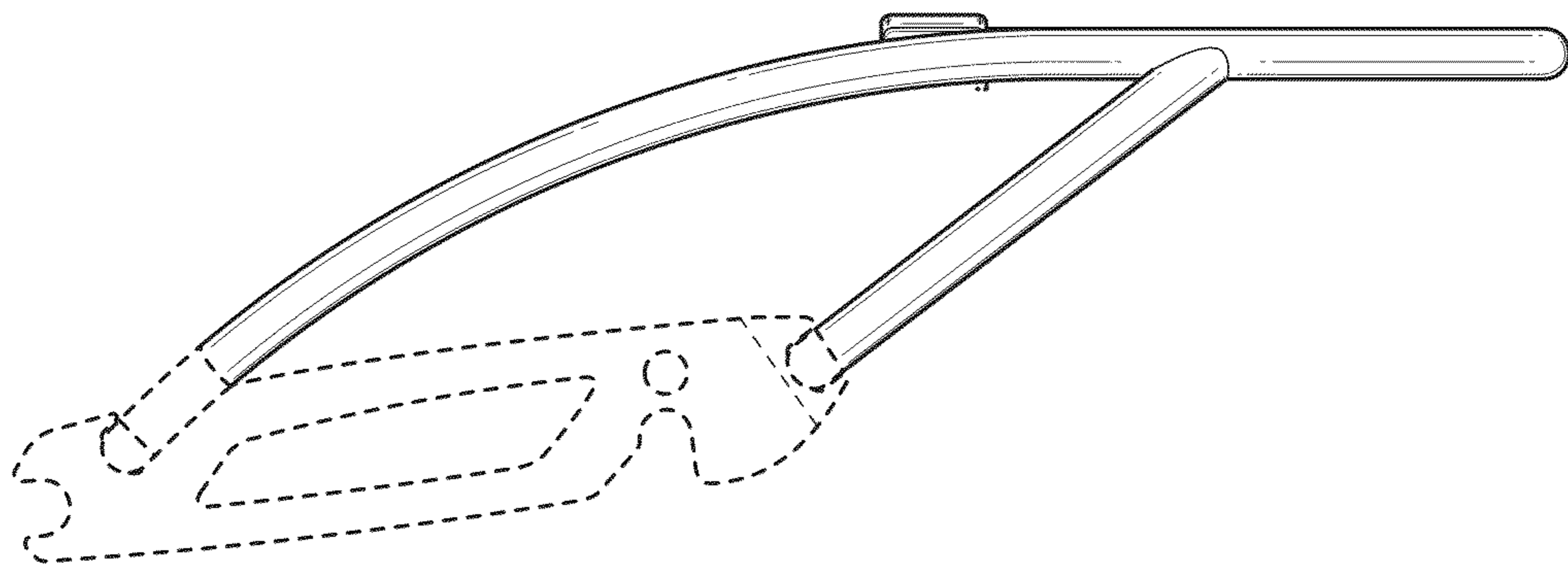

FIG. 4

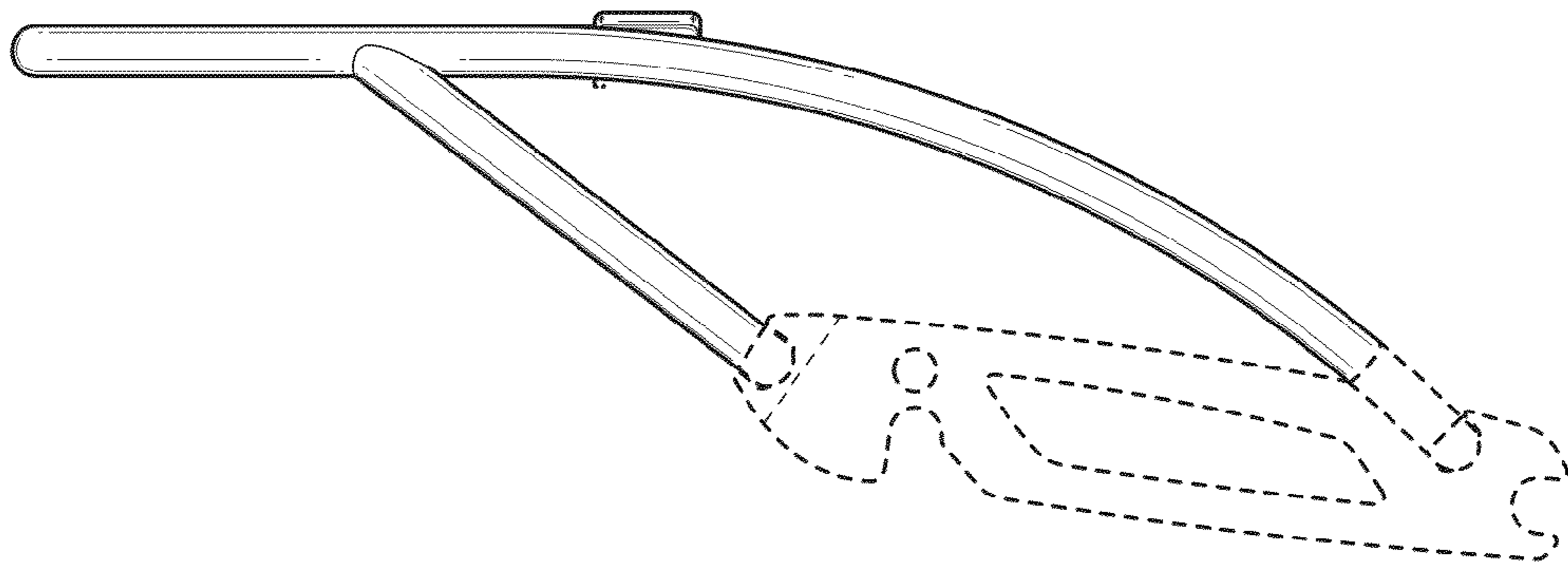

FIG. 5

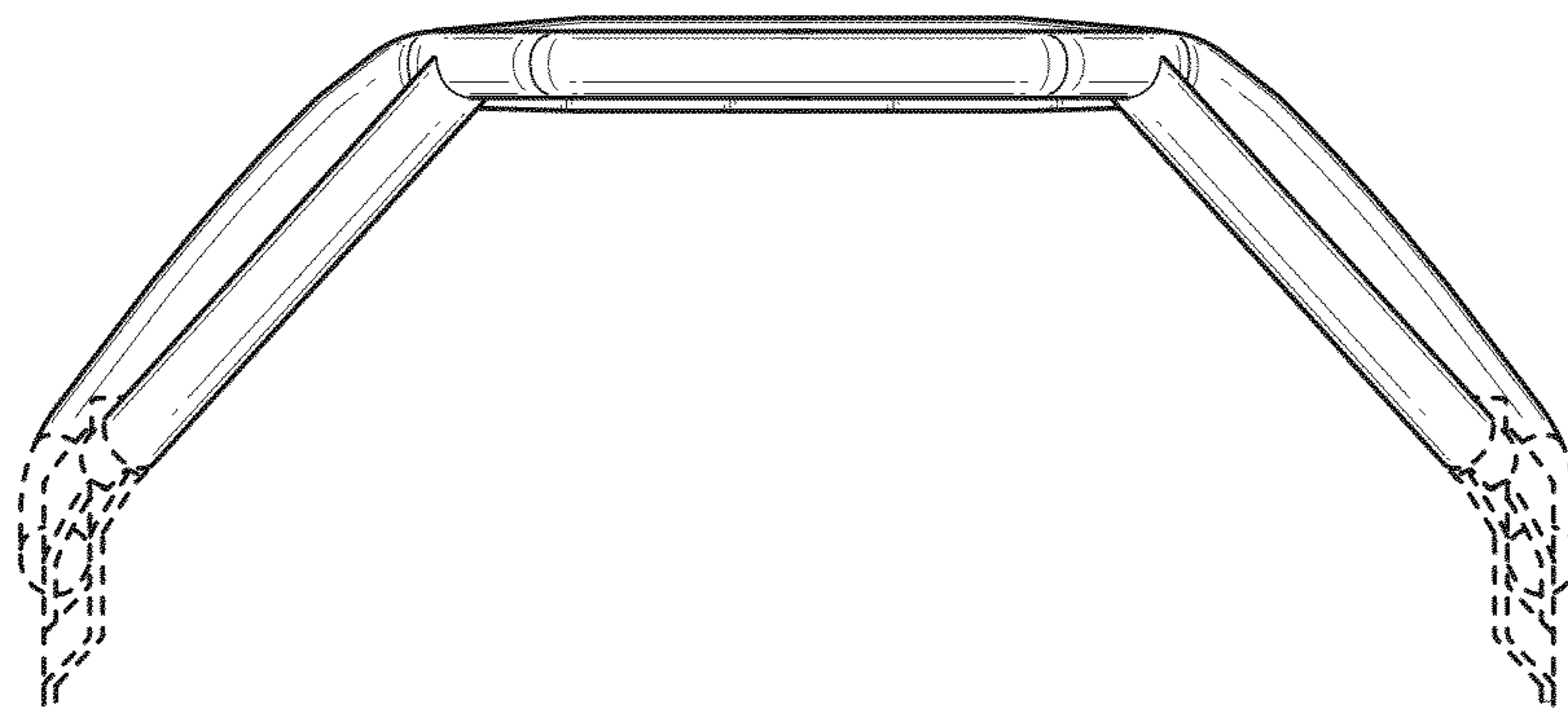

FIG. 6

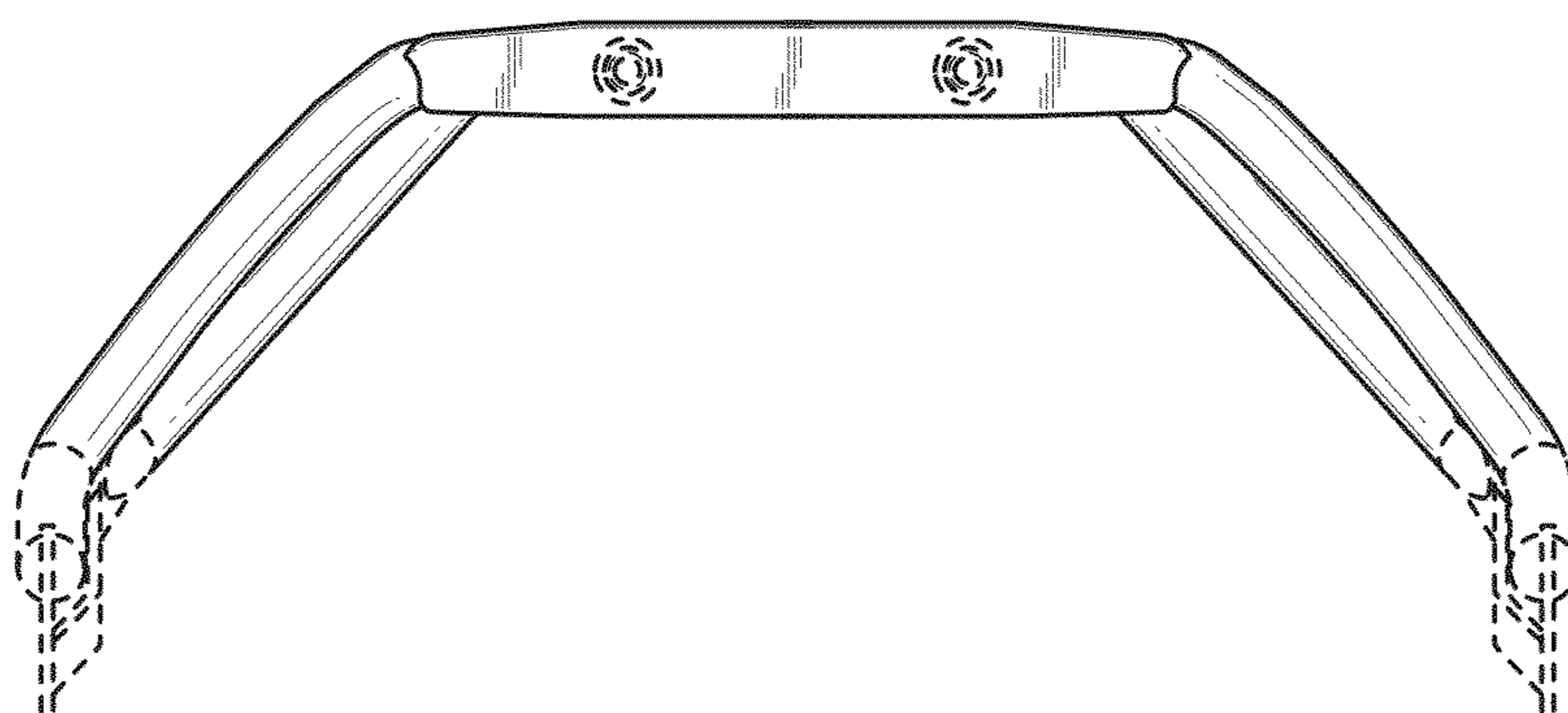

FIG. 7