



US00D735629S

(12) **United States Design Patent**  
**Fickling**

(10) **Patent No.:** **US D735,629 S**

(45) **Date of Patent:** **\*\* Aug. 4, 2015**

(54) **REAR BAR FOR VEHICLE**

(71) Applicant: **ARB Corporation Limited**, Kilsyth,  
VIC (AU)

(72) Inventor: **Ethan Fickling**, Kilsyth (AU)

(73) Assignee: **ARB CORPORATION LIMITED**,  
Kilsyth (AU)

(\*\*) Term: **14 Years**

(21) Appl. No.: **29/477,197**

(22) Filed: **Dec. 19, 2013**

(30) **Foreign Application Priority Data**

Oct. 28, 2013 (AU) ..... 15506/2013

(51) **LOC (10) Cl.** ..... **12-16**

(52) **U.S. Cl.**  
USPC ..... **D12/202**

(58) **Field of Classification Search**  
USPC ..... D12/202, 400, 196; 141/462-466, 400;  
296/146.11; 362/496, 500, 505,  
362/540-541; 224/42.21-23, 538  
CPC ..... B62D 43/02; B60R 11/06; B60R 9/06;  
B60D 1/58; B60D 1/075  
See application file for complete search history.

(56) **References Cited**

**U.S. PATENT DOCUMENTS**

D216,967 S \* 3/1970 Harden ..... D12/202  
D251,839 S \* 5/1979 Bodde ..... D12/202  
D256,345 S \* 8/1980 Weiler ..... D12/202

D289,030 S \* 3/1987 Bowman ..... D12/202  
D308,959 S \* 7/1990 Ware ..... D12/202  
D310,507 S \* 9/1990 Ware ..... D12/202  
D424,005 S \* 5/2000 Henry ..... D12/202  
D473,835 S \* 4/2003 Roehmer et al. .... D12/202  
D505,649 S \* 5/2005 Kenney ..... D12/202  
D562,206 S \* 2/2008 Newbill ..... D12/202  
D609,619 S \* 2/2010 Newbill ..... D12/202  
D633,024 S \* 2/2011 Harriton ..... D12/202  
D720,673 S \* 1/2015 Fickling ..... D12/202

\* cited by examiner

*Primary Examiner* — Stacia Cadmus

(74) *Attorney, Agent, or Firm* — Davis Wright Tremaine  
LLP; Heather M. Colburn

(57) **CLAIM**

The ornamental design for a rear bar for vehicle, as shown and  
described.

**DESCRIPTION**

FIG. 1 is a left side, rear perspective view of a rear bar for  
vehicle showing my new design;  
FIG. 2 is a rear view thereof;  
FIG. 3 is a top plan view thereof;  
FIG. 4 is a left side view thereof, the right side view being a  
mirror image of the left side view;  
FIG. 5 is a left side, rear perspective view of a second embodi-  
ment of the rear bar for vehicle;  
FIG. 6 is a rear view thereof;  
FIG. 7 is a top plan view thereof; and,  
FIG. 8 is a left side view thereof, the right side view being a  
mirror image of the left side view.  
The broken lines represent portions of the rear bar for vehicle  
that form no part of the claim.

**1 Claim, 8 Drawing Sheets**

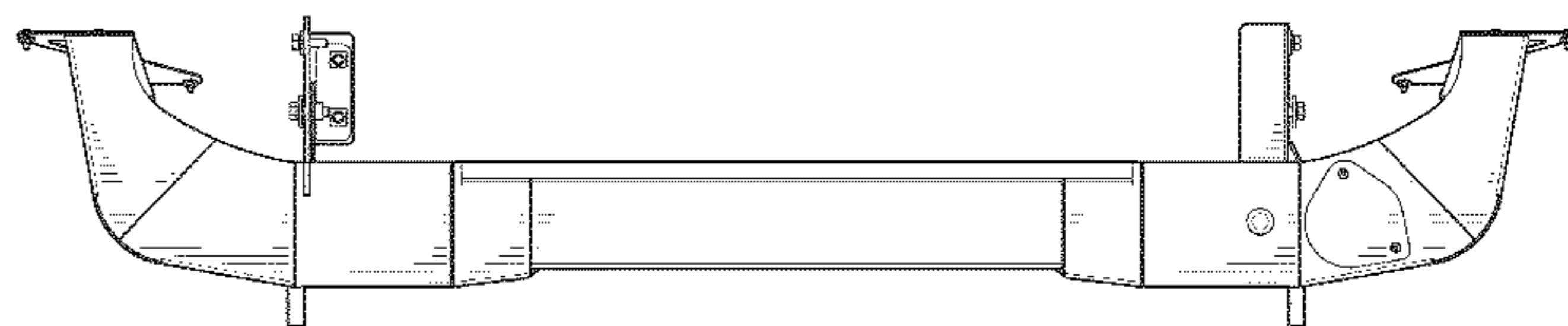
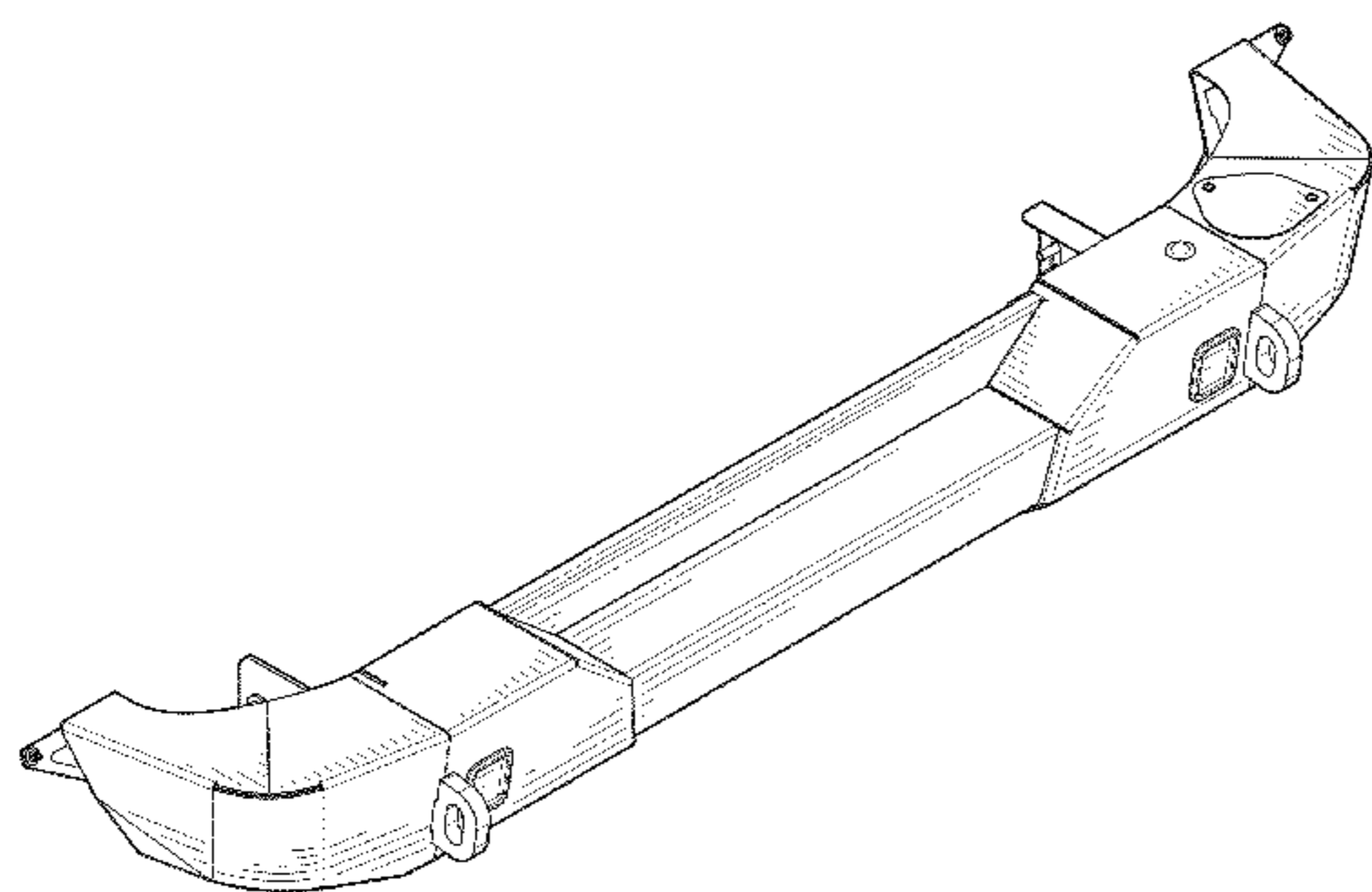

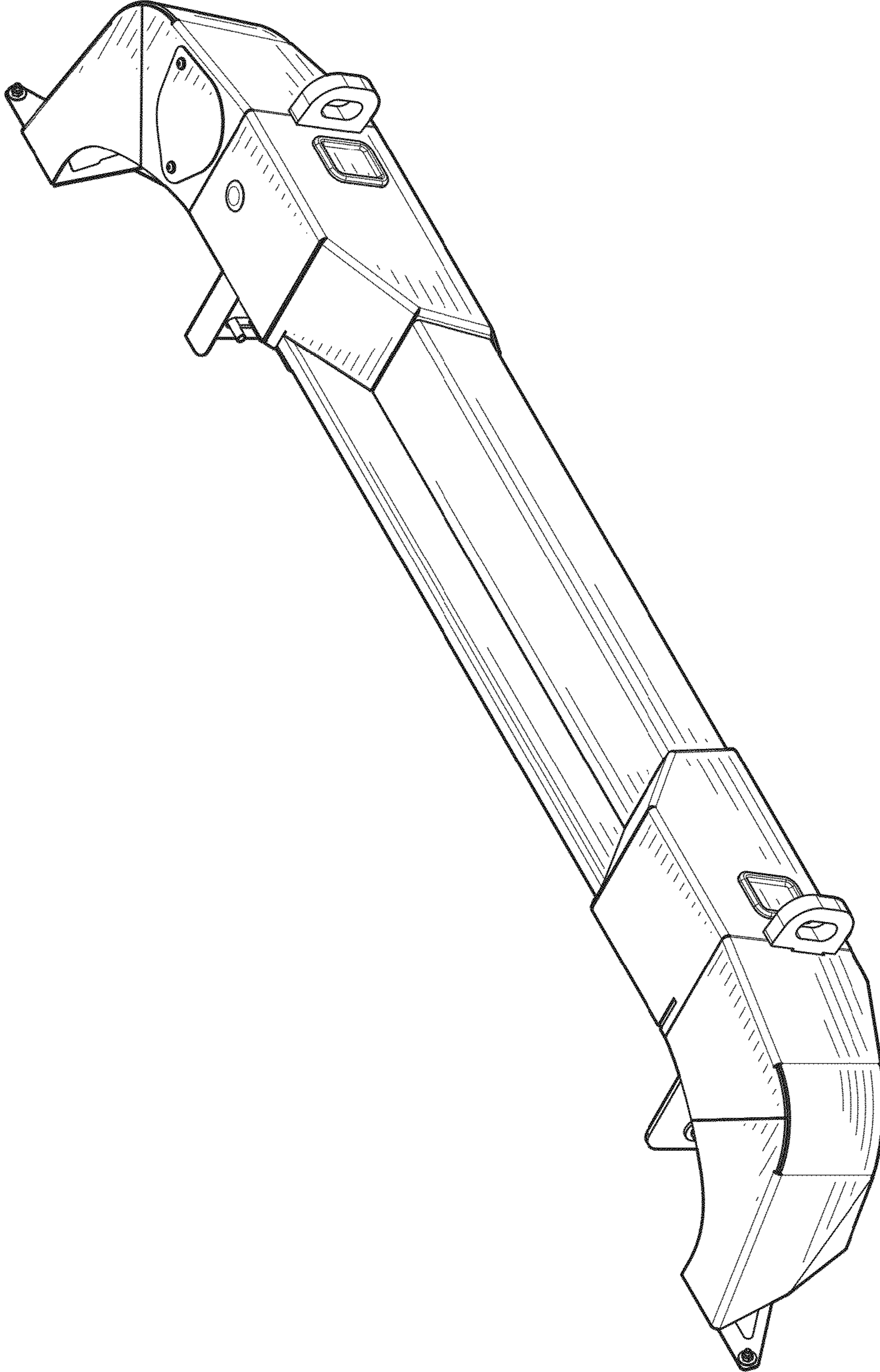

FIG.1

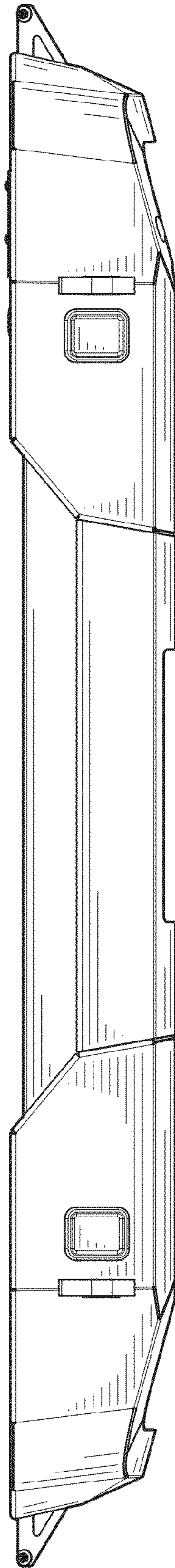

FIG. 2

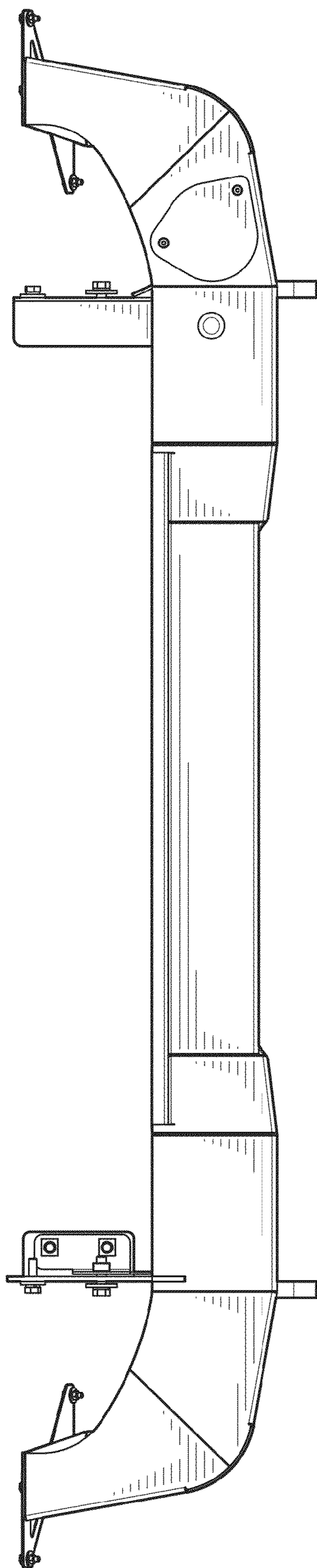

FIG. 3

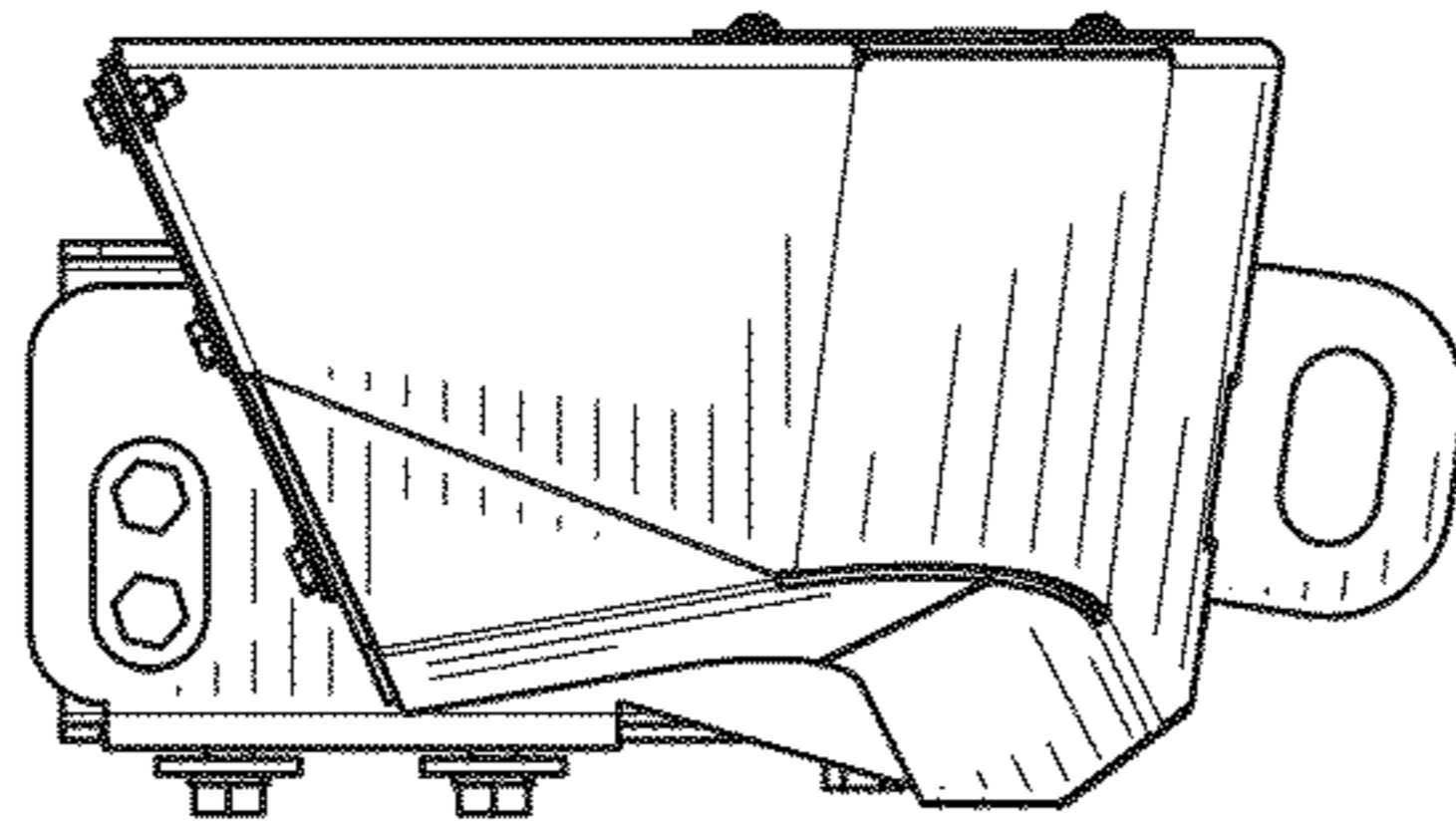

FIG.4

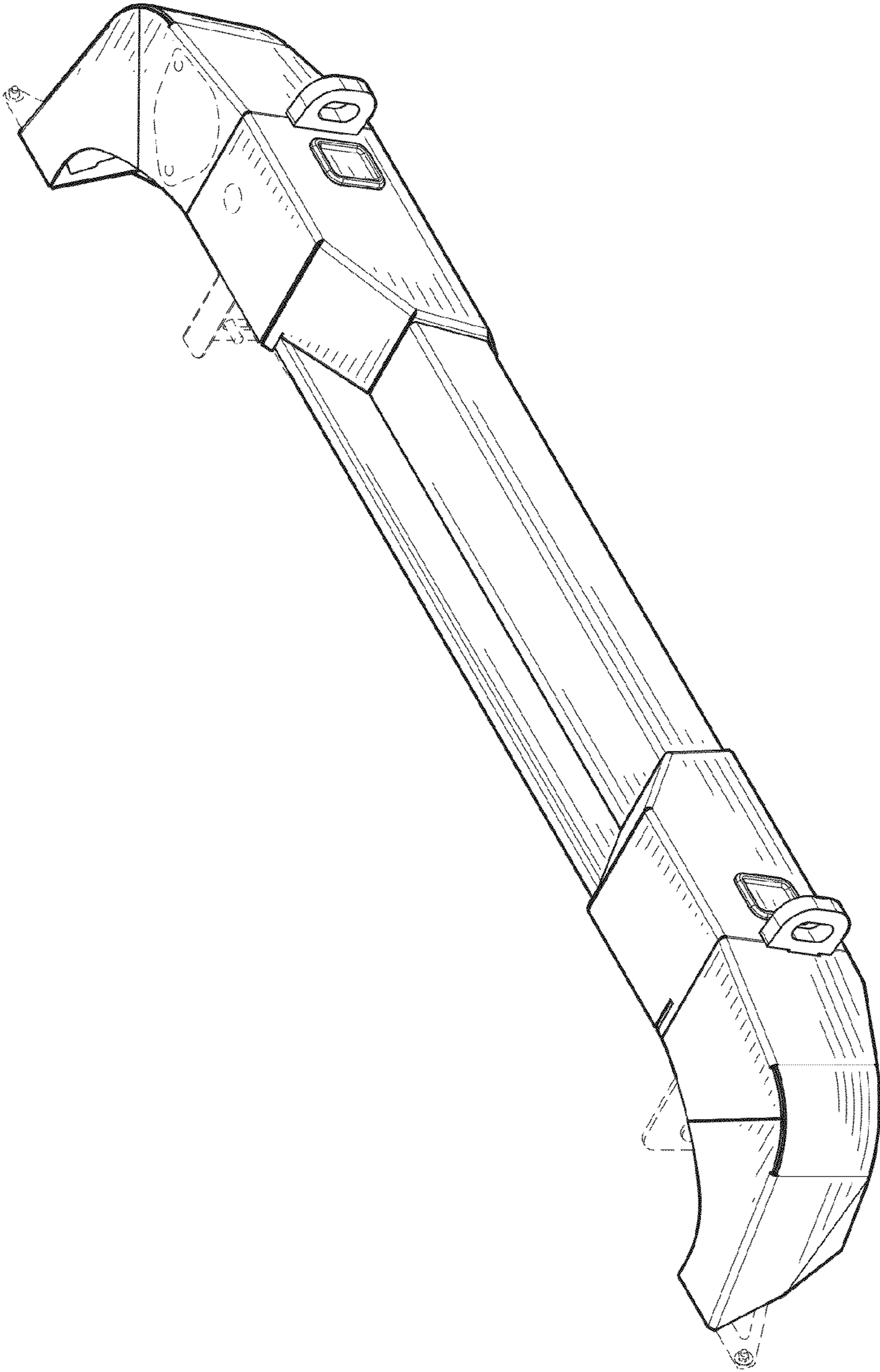

FIG. 5

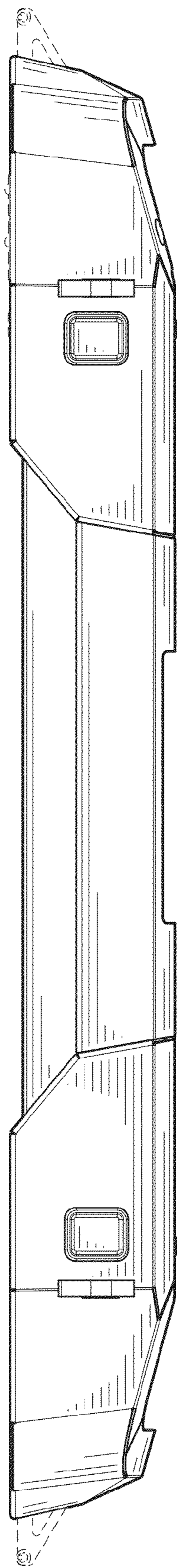

FIG. 6

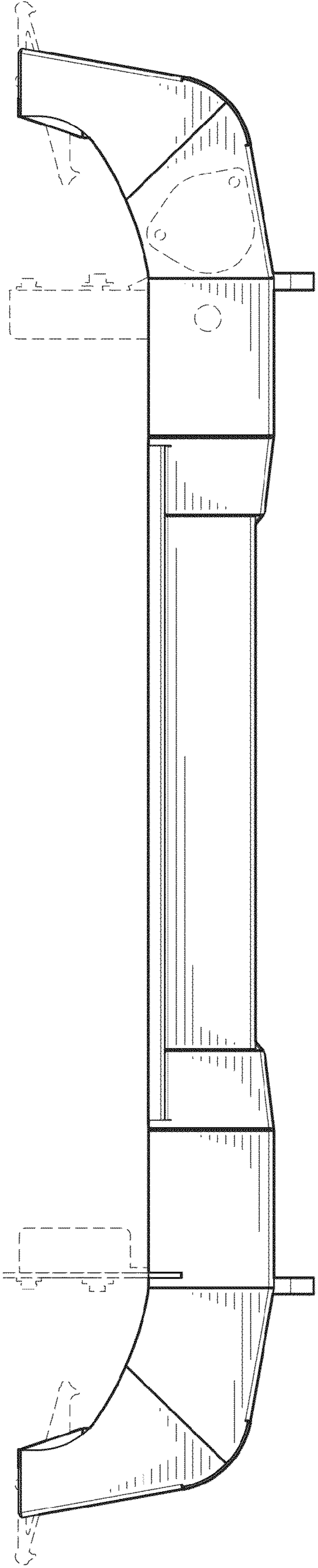

FIG. 7



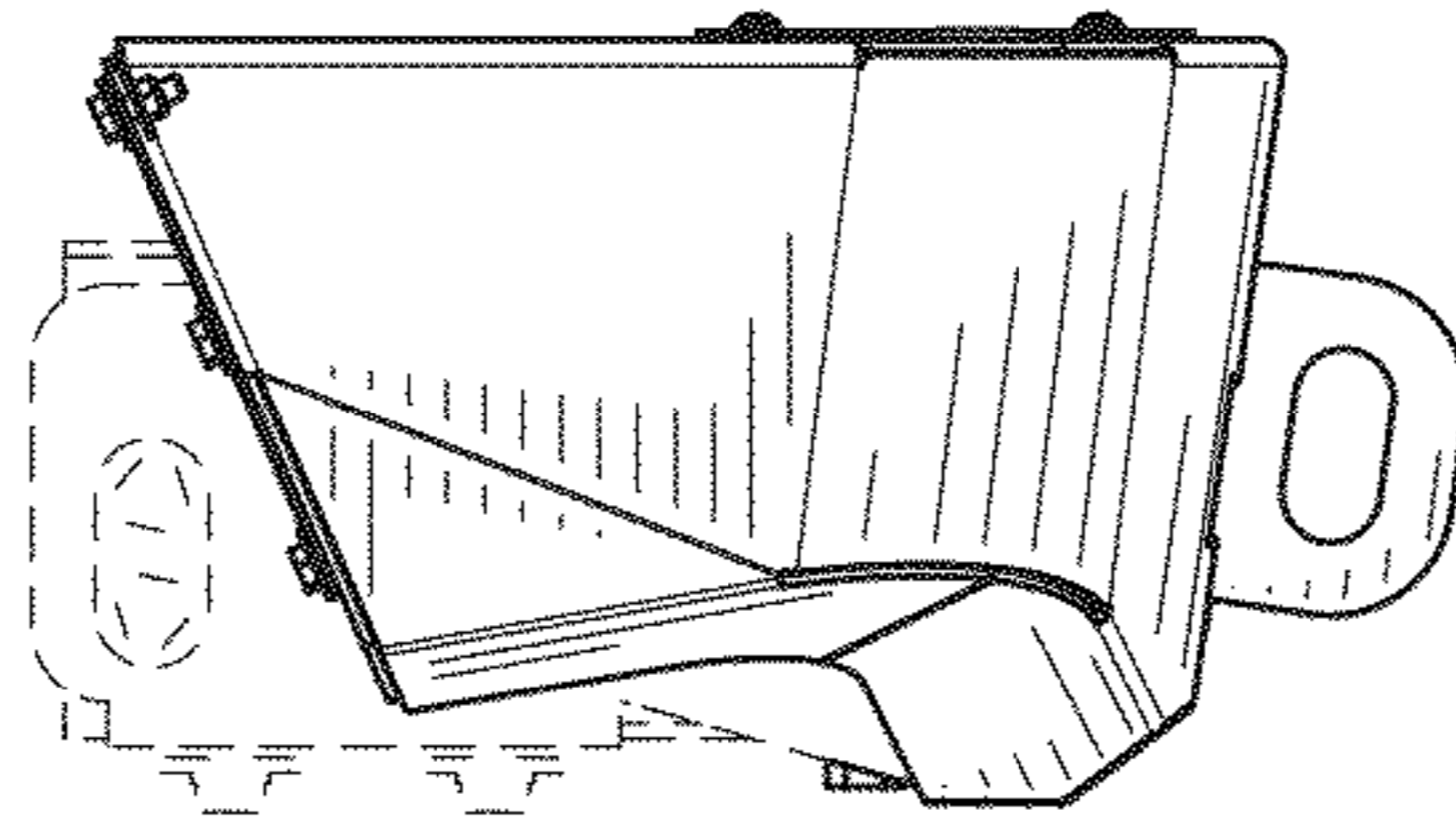

FIG. 8