



US00D735616S

(12) **United States Design Patent**
Tako et al.

(10) **Patent No.:** **US D735,616 S**
(45) **Date of Patent:** **** Aug. 4, 2015**

(54) **MOTORCYCLE**

(71) Applicant: **HONDA MOTOR CO., LTD.**, Tokyo (JP)

(72) Inventors: **Kenji Tako**, Wako (JP); **Hirotsugu Ueno**, Wako (JP)

(73) Assignee: **HONDA MOTORS CO., LTD.**, Tokyo (JP)

(**) Term: **14 Years**

(21) Appl. No.: **29/476,351**

(22) Filed: **Dec. 12, 2013**

(30) **Foreign Application Priority Data**

Jun. 13, 2013 (JP) 2013-013388

(51) **LOC (10) Cl.** **12-11**

(52) **U.S. Cl.**
USPC **D12/110**

(58) **Field of Classification Search**
USPC D12/110, 107, 182, 194, 126, 114, 117,
D12/218; D21/538, 432; D26/28;
296/193.09, 78.1, 198, 105; 180/219,
180/220, 225, 229; 280/281.1
See application file for complete search history.

(56) **References Cited**

U.S. PATENT DOCUMENTS

D286,519 S *	11/1986	Komuro et al.	D12/110
D378,204 S *	2/1997	Heinrich et al.	D12/110
D384,916 S *	10/1997	Rodriguez Ferre	D12/110
D406,801 S *	3/1999	Robb et al.	D12/110
D417,415 S *	12/1999	Hoagland, IV	D12/110
D426,174 S *	6/2000	Sofue et al.	D12/110
D444,419 S *	7/2001	Kamata et al.	D12/110
D476,271 S *	6/2003	Abe et al.	D12/110
D519,415 S *	4/2006	Hohdorf et al.	D12/110
D530,244 S *	10/2006	Wilm et al.	D12/110

D574,299 S *	8/2008	Kouchi et al.	D12/110
D597,891 S *	8/2009	Andoh	D12/110
D605,982 S *	12/2009	Tanaka et al.	D12/110
D624,853 S *	10/2010	Song et al.	D12/110
D625,229 S *	10/2010	Tako et al.	D12/126
D637,525 S *	5/2011	Sugimoto	D12/110
D656,068 S *	3/2012	Song et al.	D12/110
D656,069 S *	3/2012	Itaya et al.	D12/110
D656,867 S *	4/2012	Uemoto et al.	D12/110
D665,310 S *	8/2012	Hohdorf et al.	D12/110
D666,531 S *	9/2012	Dunshee	D12/110
D686,538 S *	7/2013	Nagao	D12/110
D691,069 S *	10/2013	Tsukui et al.	D12/110
D692,355 S *	10/2013	Tsuji et al.	D12/110
D713,475 S *	9/2014	Hui	D21/538
D722,538 S *	2/2015	Song et al.	D12/110

* cited by examiner

Primary Examiner — Robert M Spear

Assistant Examiner — Ryan Harvey

(74) *Attorney, Agent, or Firm* — Westerman, Hattori, Daniels & Adrian, LLP

(57) **CLAIM**

The ornamental design for a motorcycle, as shown and described.

DESCRIPTION

FIG. 1 is a front elevational view of the motorcycle showing our new design;

FIG. 2 is a rear elevational view thereof;

FIG. 3 is a top plan view thereof;

FIG. 4 is a bottom plan view thereof;

FIG. 5 is a left side elevational view thereof;

FIG. 6 is a right side elevational view thereof;

FIG. 7 is a left front perspective view thereof;

FIG. 8 is a right front perspective view thereof;

FIG. 9 is a left rear perspective view thereof; and,

FIG. 10 is a right rear perspective view thereof.

The broken lines illustrate environmental structure only and form no part of the claimed design.

1 Claim, 5 Drawing Sheets

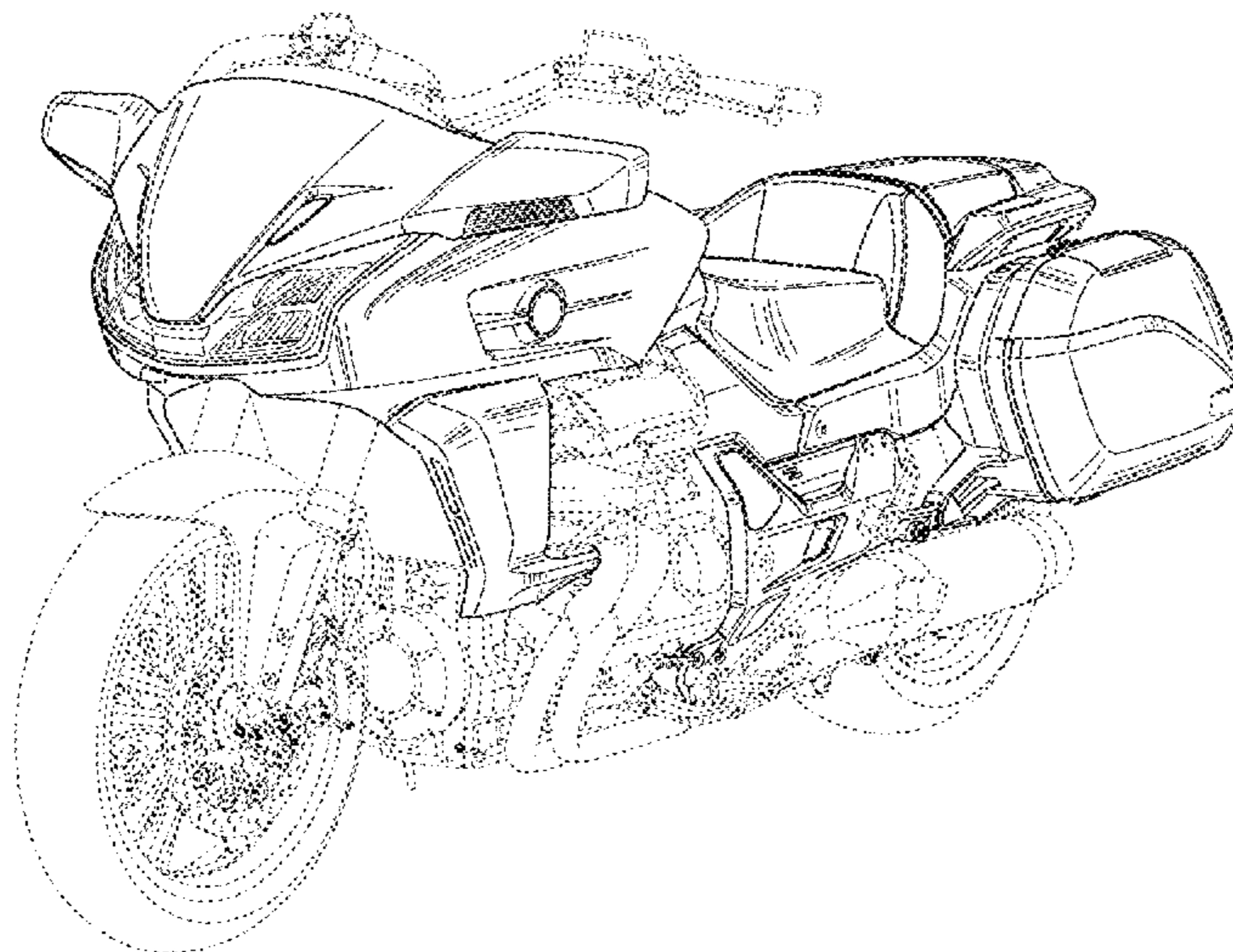

FIG.1

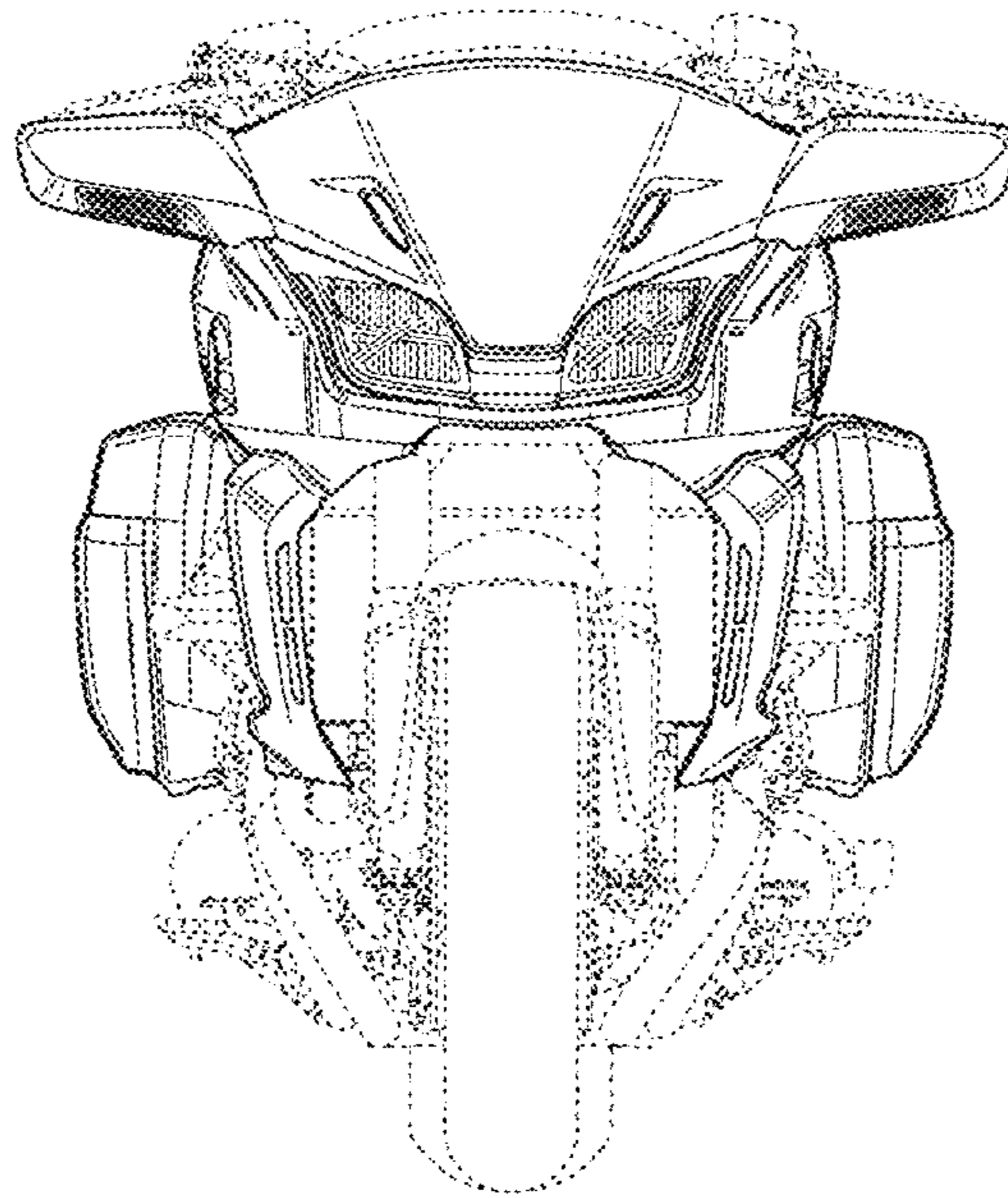

FIG.2

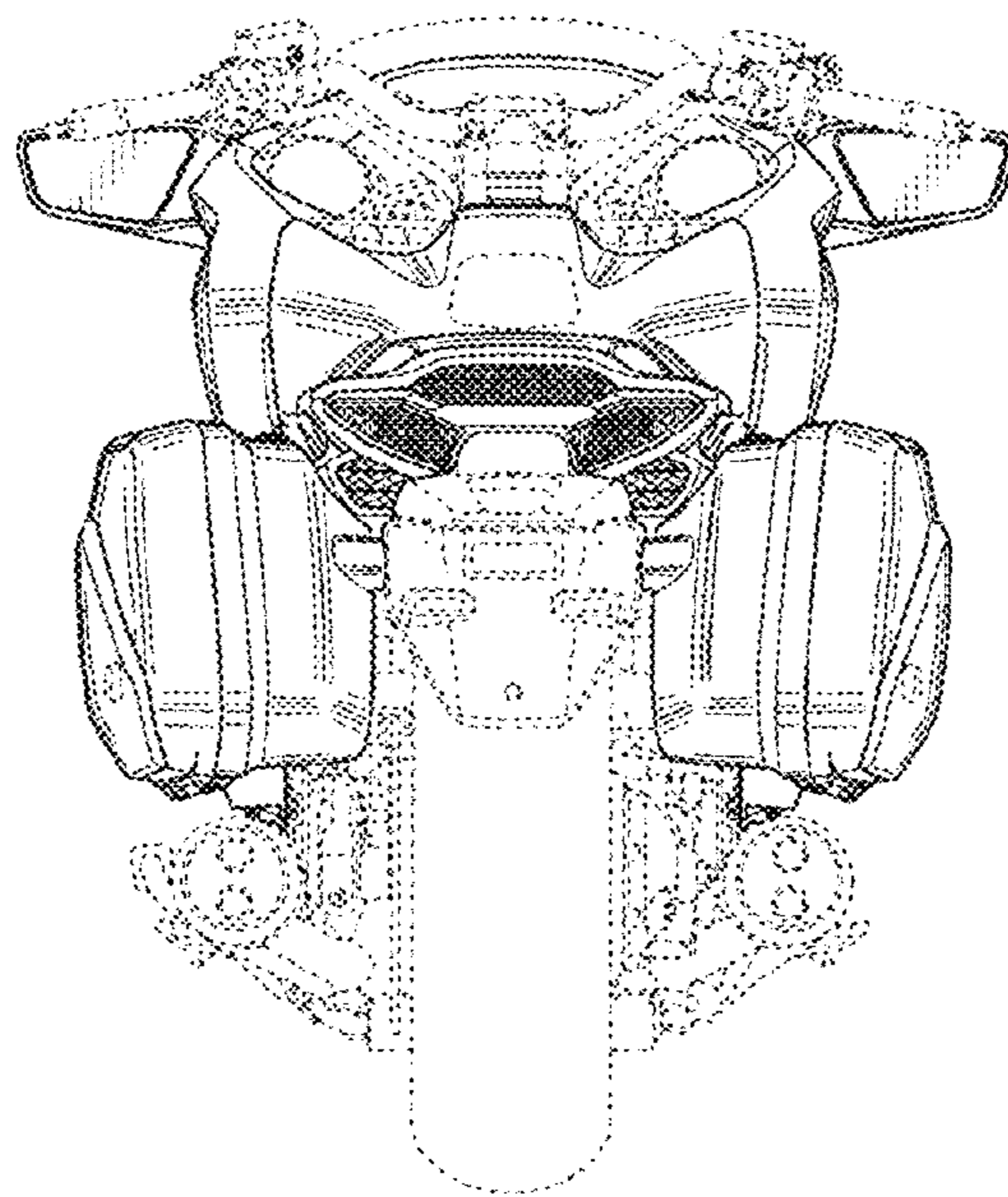

FIG.3

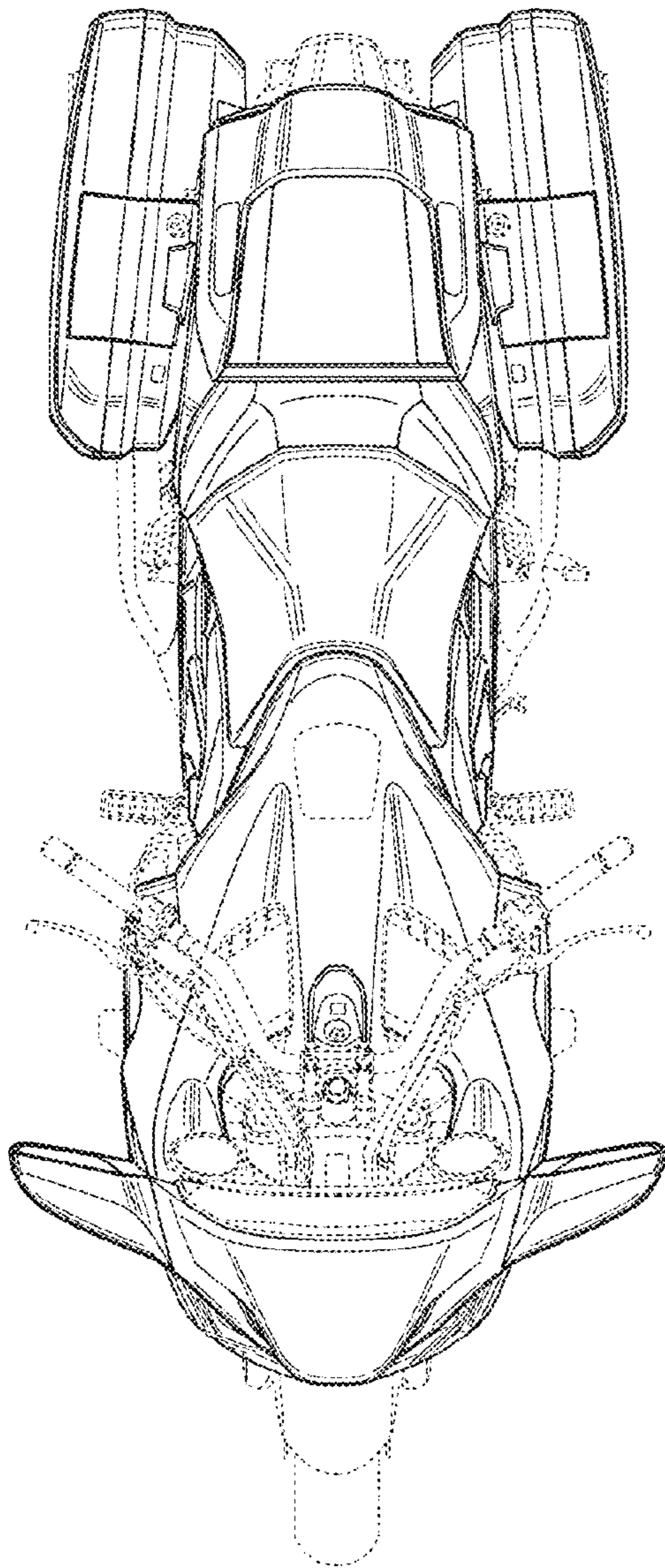

FIG.4

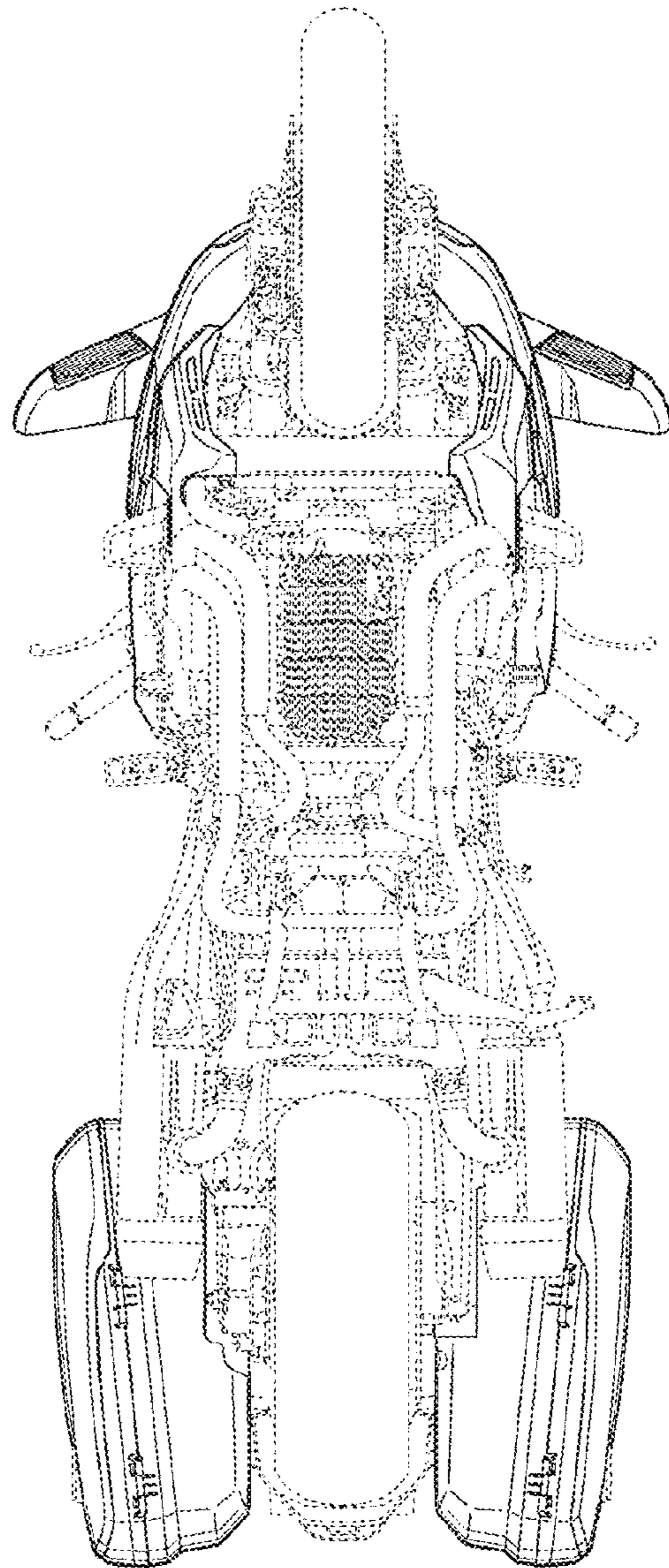

FIG.5

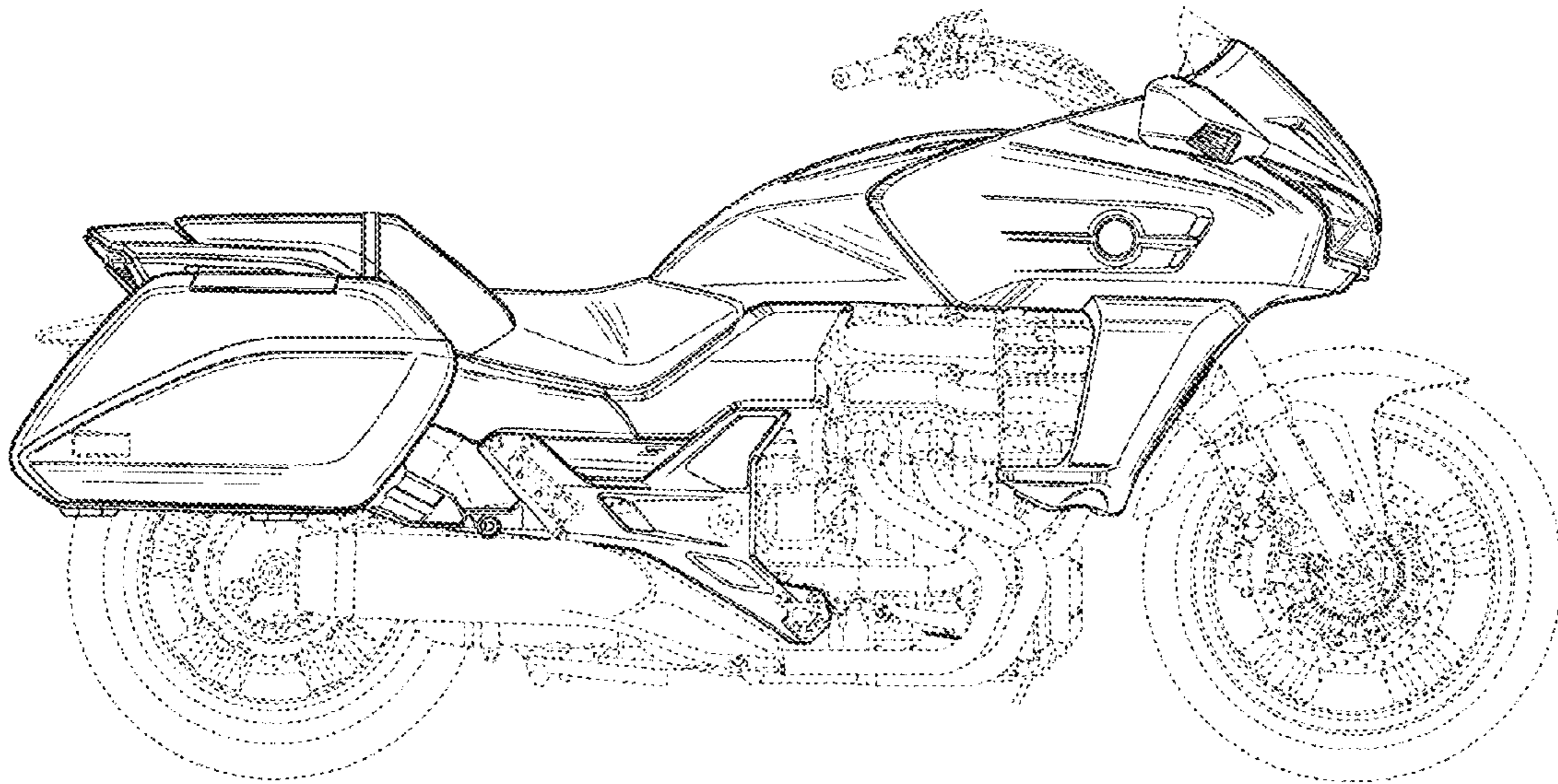

FIG.6

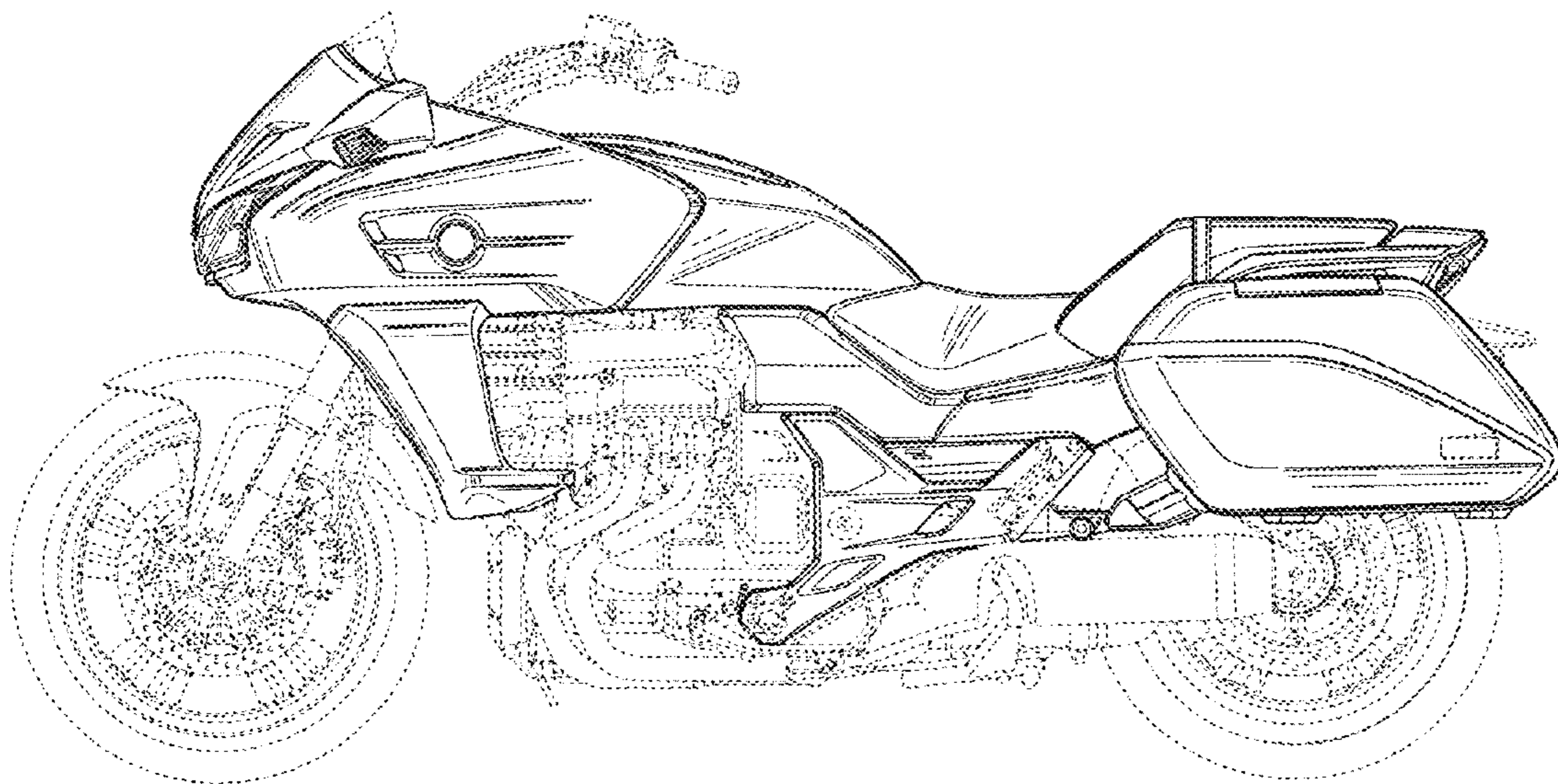

FIG.7

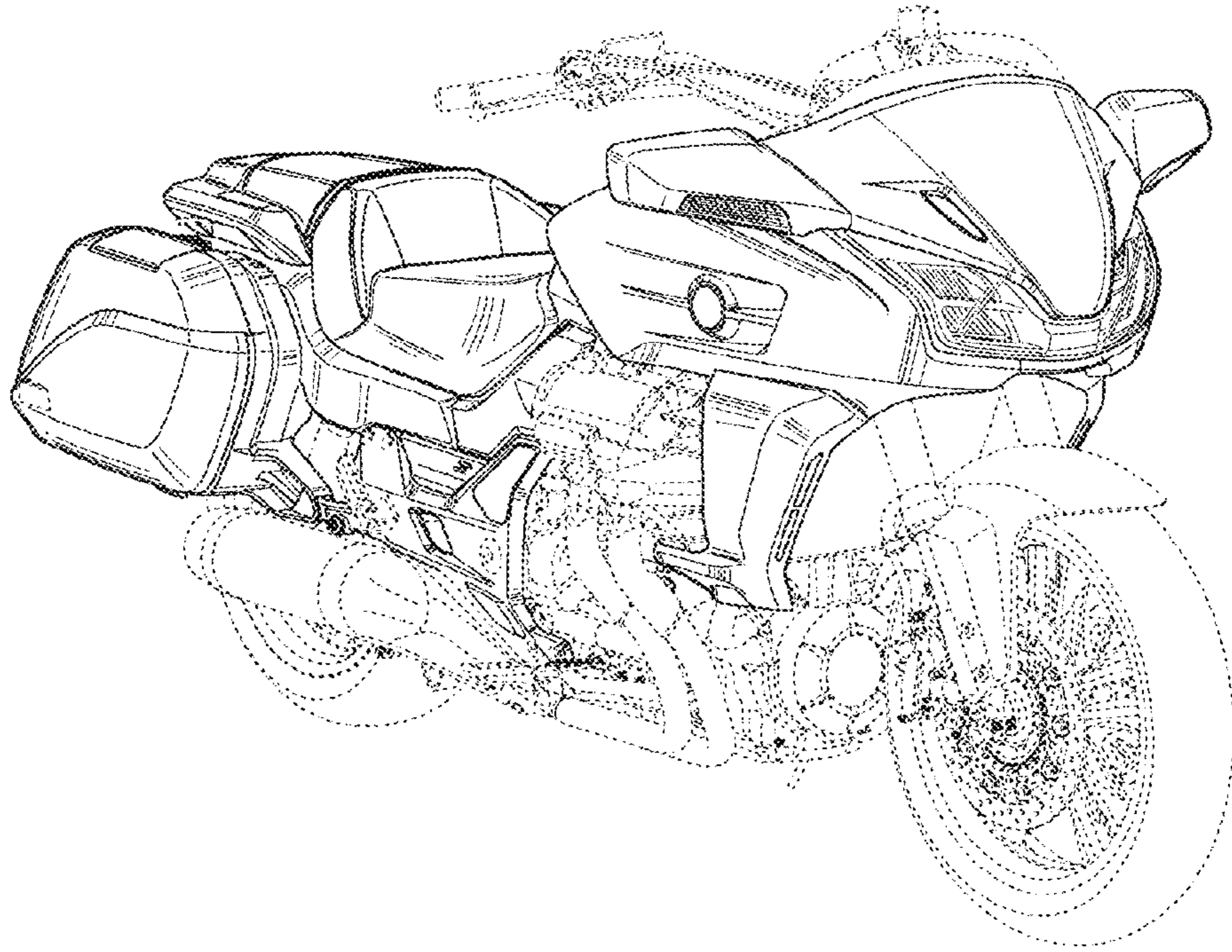

FIG.8

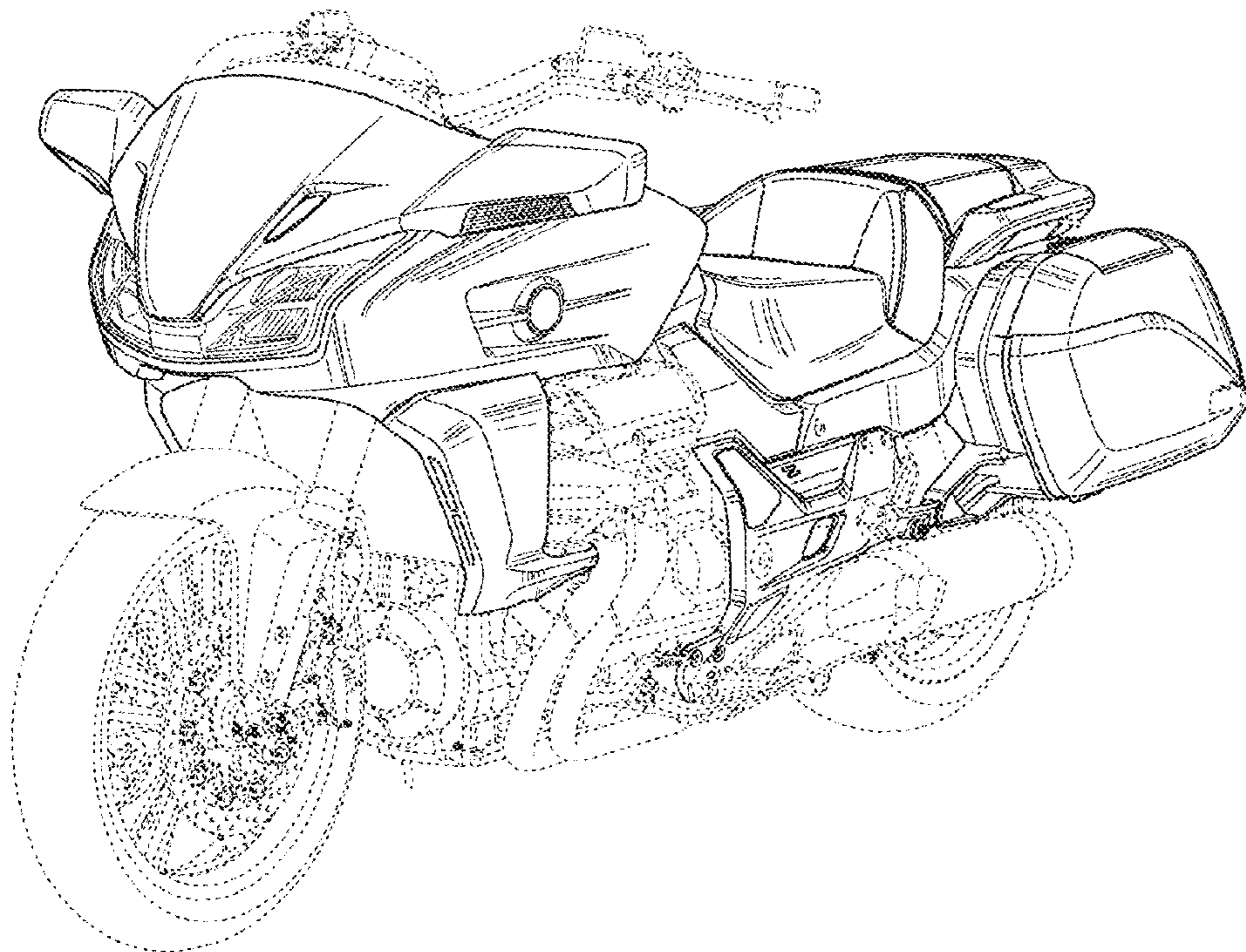

FIG.9

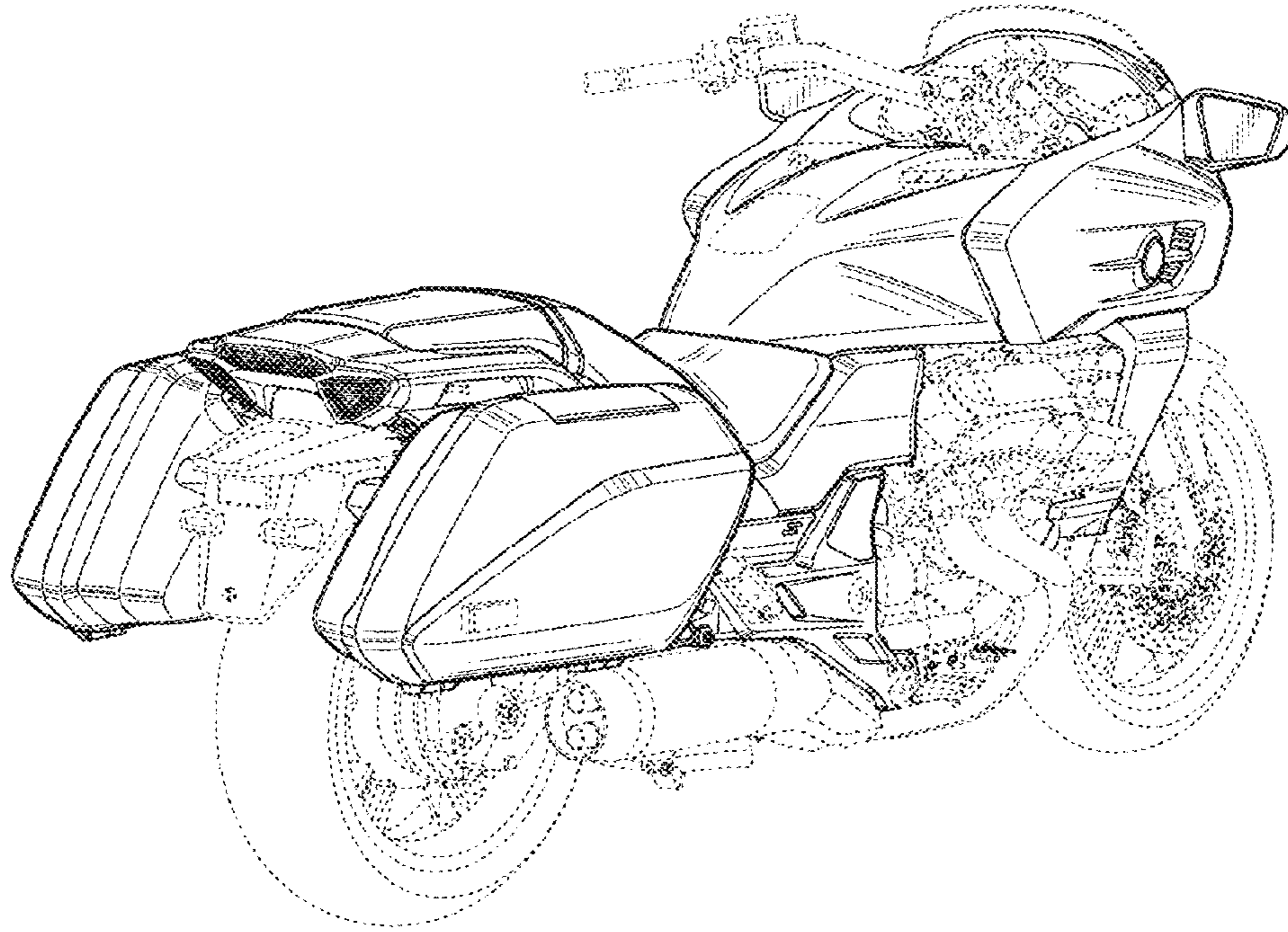
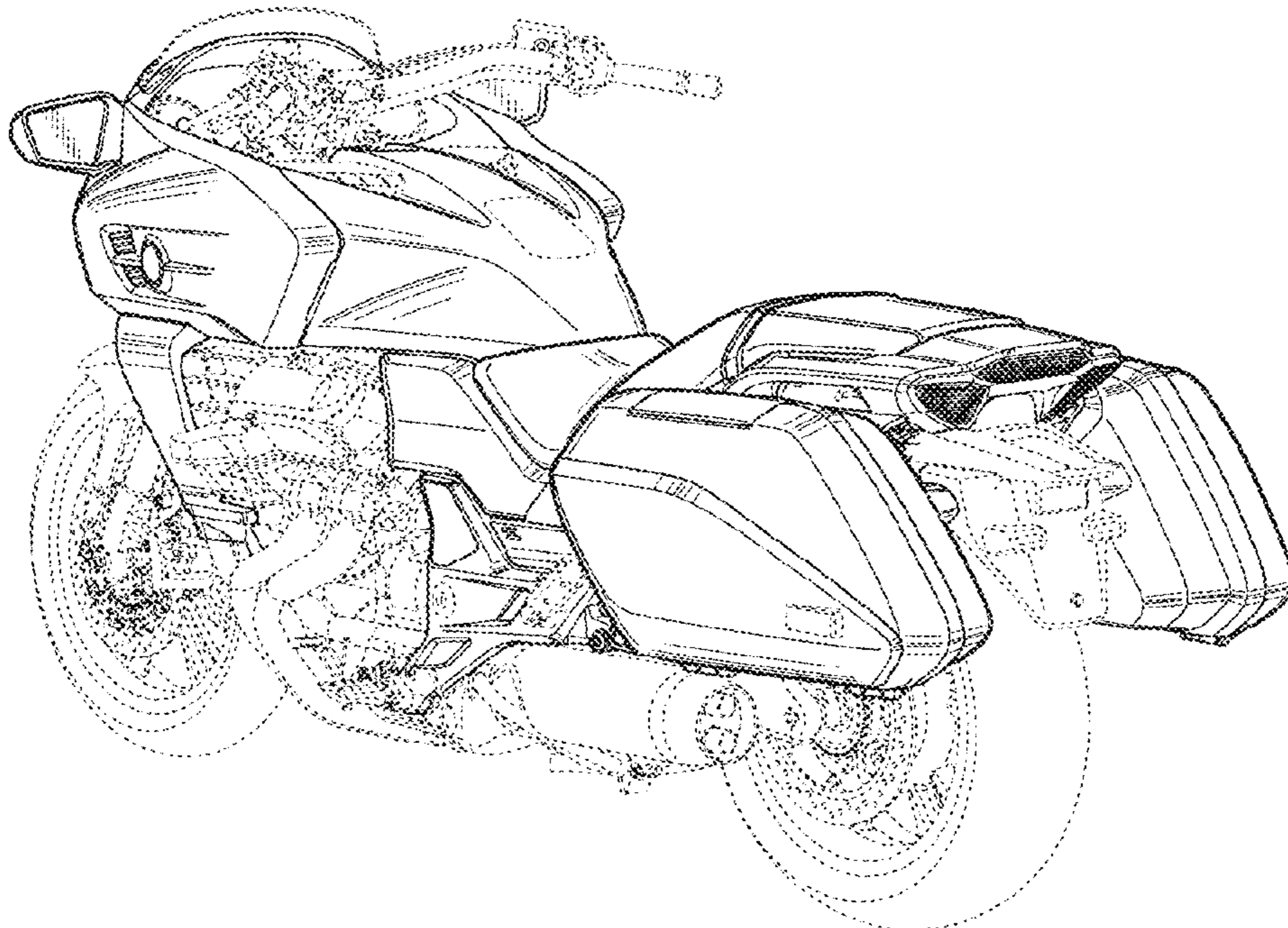

FIG.10



UNITED STATES PATENT AND TRADEMARK OFFICE
CERTIFICATE OF CORRECTION

PATENT NO. : D735,616 S
APPLICATION NO. : 29/476351
DATED : August 4, 2015
INVENTOR(S) : Kenji Tako et al.

Page 1 of 1

It is certified that error appears in the above-identified patent and that said Letters Patent is hereby corrected as shown below:

On the title page item (73)

Change

(73) Assignee: Honda Motors Co., LTD., Tokyo (JP)

To be

(73) Assignee: Honda Motor Co., LTD., Tokyo (JP)

Signed and Sealed this
Eighth Day of March, 2016



Michelle K. Lee
Director of the United States Patent and Trademark Office