



US00D735608S

(12) **United States Design Patent**  
**Cao et al.**

(10) **Patent No.:** **US D735,608 S**  
(45) **Date of Patent:** **\*\* Aug. 4, 2015**

(54) **THREE WHEELED VEHICLE**

D626,031 S \* 10/2010 Doran ..... D12/1  
D626,032 S 10/2010 Starr

(71) Applicant: **T3 Motion, Inc.**, Costa Mesa, CA (US)

(Continued)

(72) Inventors: **Kenneth Tien Cao**, Laguna Niguel, CA (US); **Hung Pham**, Stanton, CA (US); **Richard Taras**, Anaheim, CA (US)

FOREIGN PATENT DOCUMENTS

JP 2009-154683 7/2009  
JP 2010-064560 3/2010  
WO WO-2004/020269 3/2004

(73) Assignee: **T3 Motion, Inc.**, Brea, CA (US)

OTHER PUBLICATIONS

(\*\*) Term: **14 Years**

“Office Action Dated Jan. 31, 2013, U.S. Appl. No. 29/410,658”,  
(Jan. 31, 2013).

(21) Appl. No.: **29/435,273**

(Continued)

(22) Filed: **Oct. 22, 2012**

(51) **LOC (10) Cl.** ..... **12-14**

(52) **U.S. Cl.**

USPC ..... **D12/1**

(58) **Field of Classification Search**

USPC ..... D12/1, 8, 14, 85, 86, 112, 113, 128,  
D12/130; D21/419, 421, 423, 424, 435;  
180/65.1, 65.51, 180, 181, 227, 228;  
280/282, 200, 220, 221, 263

See application file for complete search history.

*Primary Examiner* — Cathron Brooks

*Assistant Examiner* — Clese Moore, Jr.

(74) *Attorney, Agent, or Firm* — Blakely Sokoloff Taylor & Zafman LLP

(57) **CLAIM**

The ornamental design for a three wheeled vehicle, as shown and described.

(56) **References Cited**

**DESCRIPTION**

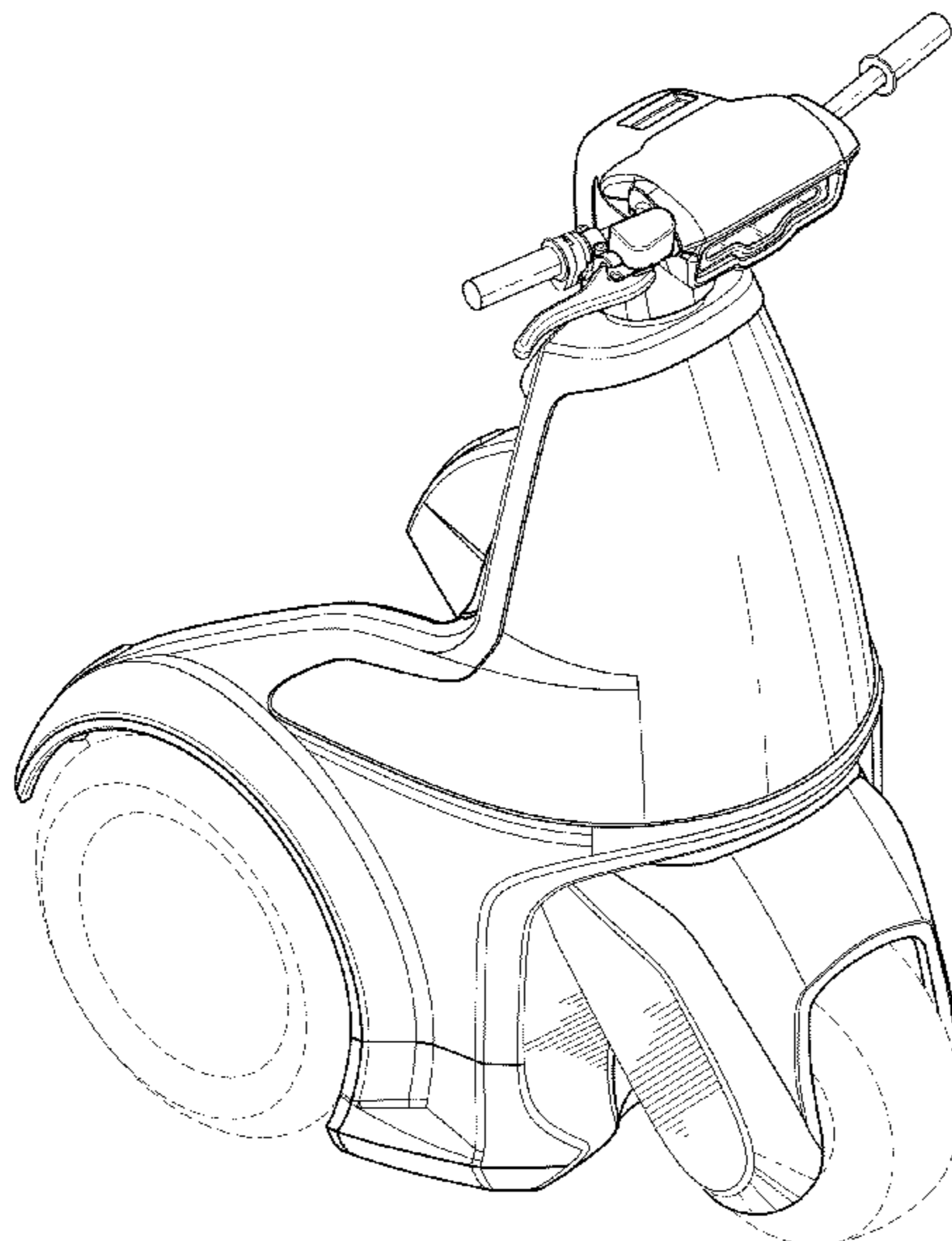
U.S. PATENT DOCUMENTS

D280,089 S \* 8/1985 Blower ..... D12/128  
D322,049 S 12/1991 Doman et al.  
D355,148 S \* 2/1995 Orsolini ..... D12/85  
D427,945 S \* 7/2000 Kirkpatrick ..... D12/112  
D428,364 S \* 7/2000 Kirkpatrick ..... D12/112  
D498,439 S \* 11/2004 Kirkpatrick et al. .... D12/112  
D507,206 S 7/2005 Wang  
D528,468 S 9/2006 Arling et al.  
D556,099 S 11/2007 Kretschmer  
D569,308 S 5/2008 Bergeron et al.  
D601,922 S 10/2009 Imai et al.  
D613,203 S 4/2010 Geslin et al.  
D614,998 S 5/2010 Fujita  
D619,045 S 7/2010 Fujita

FIG. 1 is a first perspective view of the three wheeled vehicle;  
FIG. 2 is a second perspective view thereof;  
FIG. 3 is a front view thereof;  
FIG. 4 is a rear view thereof;  
FIG. 5 is a first side view thereof;  
FIG. 6 is a second side view thereof;  
FIG. 7 is a top view thereof; and,  
FIG. 8 is a bottom view thereof.

The broken line showing of the wheels and portions of the bottom plan view are for the purpose of illustrating portions of the vehicle that form no part of the claimed design.

**1 Claim, 8 Drawing Sheets**



(56)

References Cited

U.S. PATENT DOCUMENTS

|              |      |         |               |          |
|--------------|------|---------|---------------|----------|
| D626,884     | S    | 11/2010 | Fujita        |          |
| D633,821     | S    | 3/2011  | Hill et al.   |          |
| D635,487     | S    | 4/2011  | Hill et al.   |          |
| 7,958,961    | B1 * | 6/2011  | Schade        | 180/273  |
| 8,072,185    | B2 * | 12/2011 | Nam et al.    | 320/116  |
| 8,397,854    | B1 * | 3/2013  | Nam et al.    | 180/213  |
| D699,626     | S *  | 2/2014  | Nam           | D12/1    |
| 8,783,394    | B1 * | 7/2014  | Nam et al.    | 180/61   |
| 2004/0188153 | A1 * | 9/2004  | Liu et al.    | 180/65.1 |
| 2009/0115149 | A1   | 5/2009  | Wallis et al. |          |
| 2009/0237032 | A1 * | 9/2009  | Nam et al.    | 320/116  |
| 2010/0065361 | A1 * | 3/2010  | Nam et al.    | 180/211  |
| 2013/0192908 | A1 * | 8/2013  | Schlagheck    | 180/65.1 |

OTHER PUBLICATIONS

“Security personnel to start using electric stand-up vehicles. Gulf Times—Qatar’s Top-Selling English Daily Newspaper”, Retrieved from the Internet <URL: [http://t3motion.com/printpdf/Gulf\\_Times\\_012710.pdf](http://t3motion.com/printpdf/Gulf_Times_012710.pdf)>, (Jan. 27, 2010).

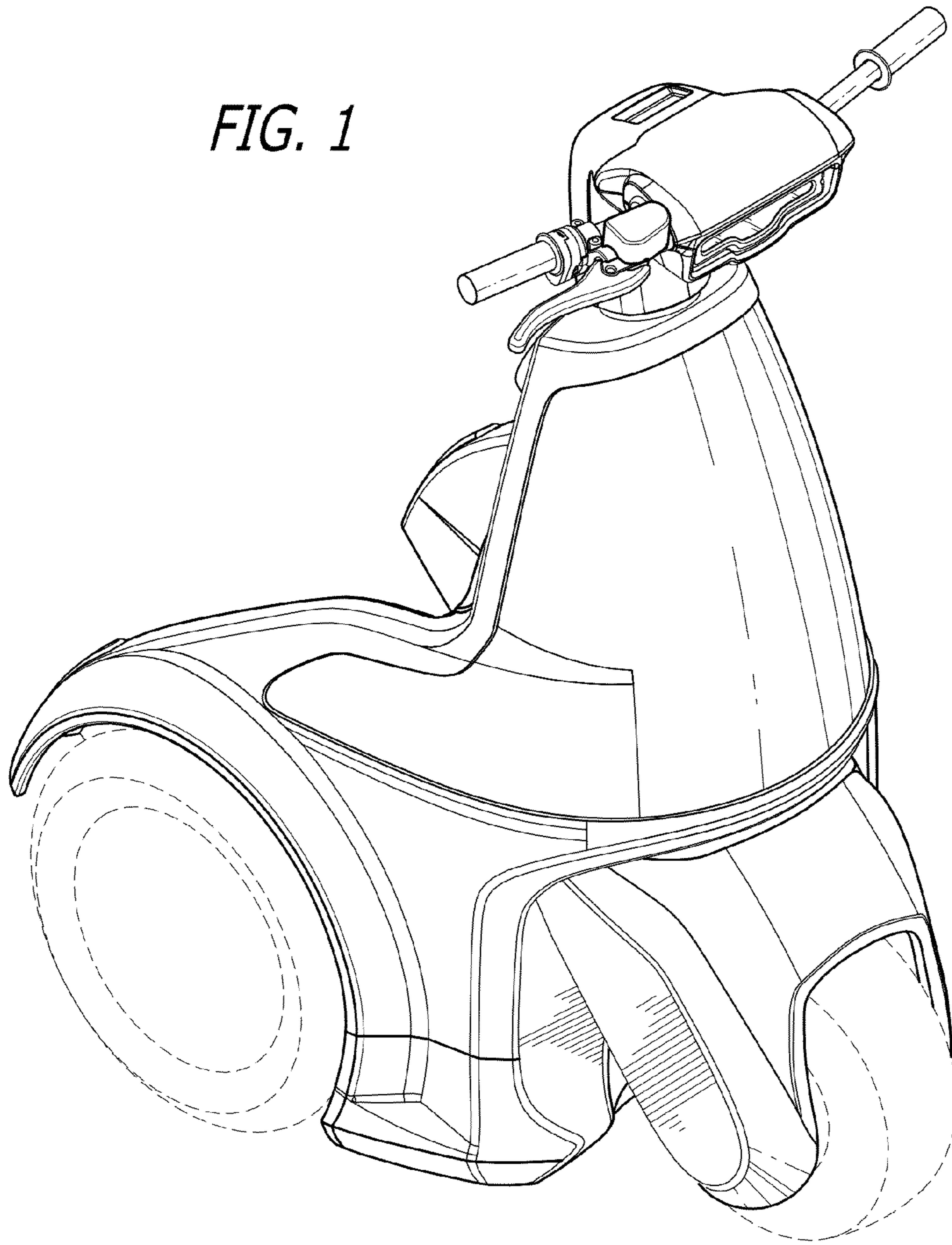
Yamamoto, Mike , “Pull over, Segway—The Cops are Coming. Police get alternative vehicle, complete siren. CNET CES Special Coverage”, Retrieved from the Internet <URL: [http://news.cnet.com/8301-17938\\_105-7654-1.html](http://news.cnet.com/8301-17938_105-7654-1.html)>, (Oct. 19, 2006).

“T3 Series ESV”, <http://t3motion.com/app-military.html>, (2010), 2 pps total.

“Notice of Allowance Dated Oct. 8, 2013; U.S. Appl. No. 29/410,658”, (Oct. 8, 2013).

\* cited by examiner

*FIG. 1*



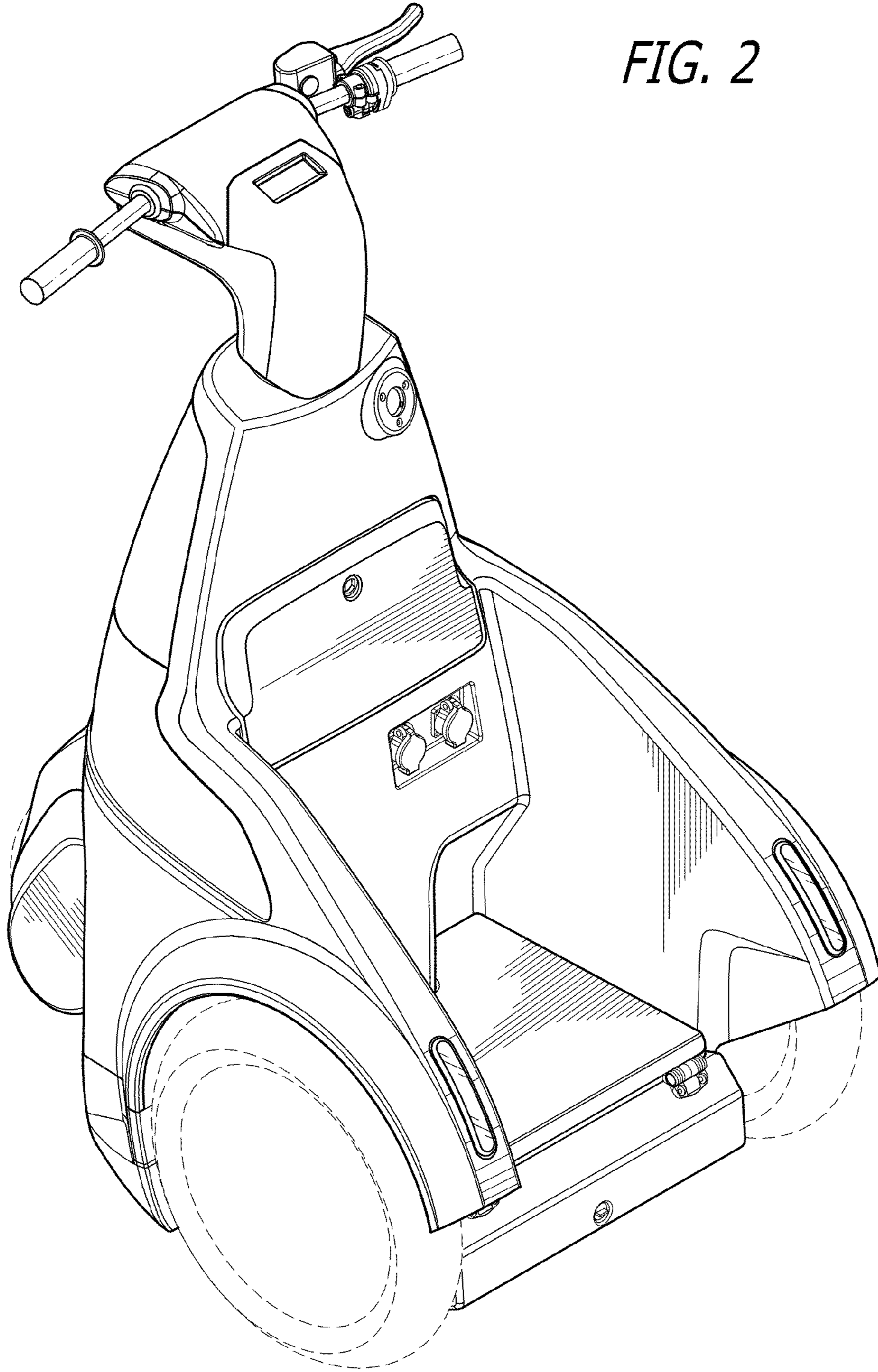
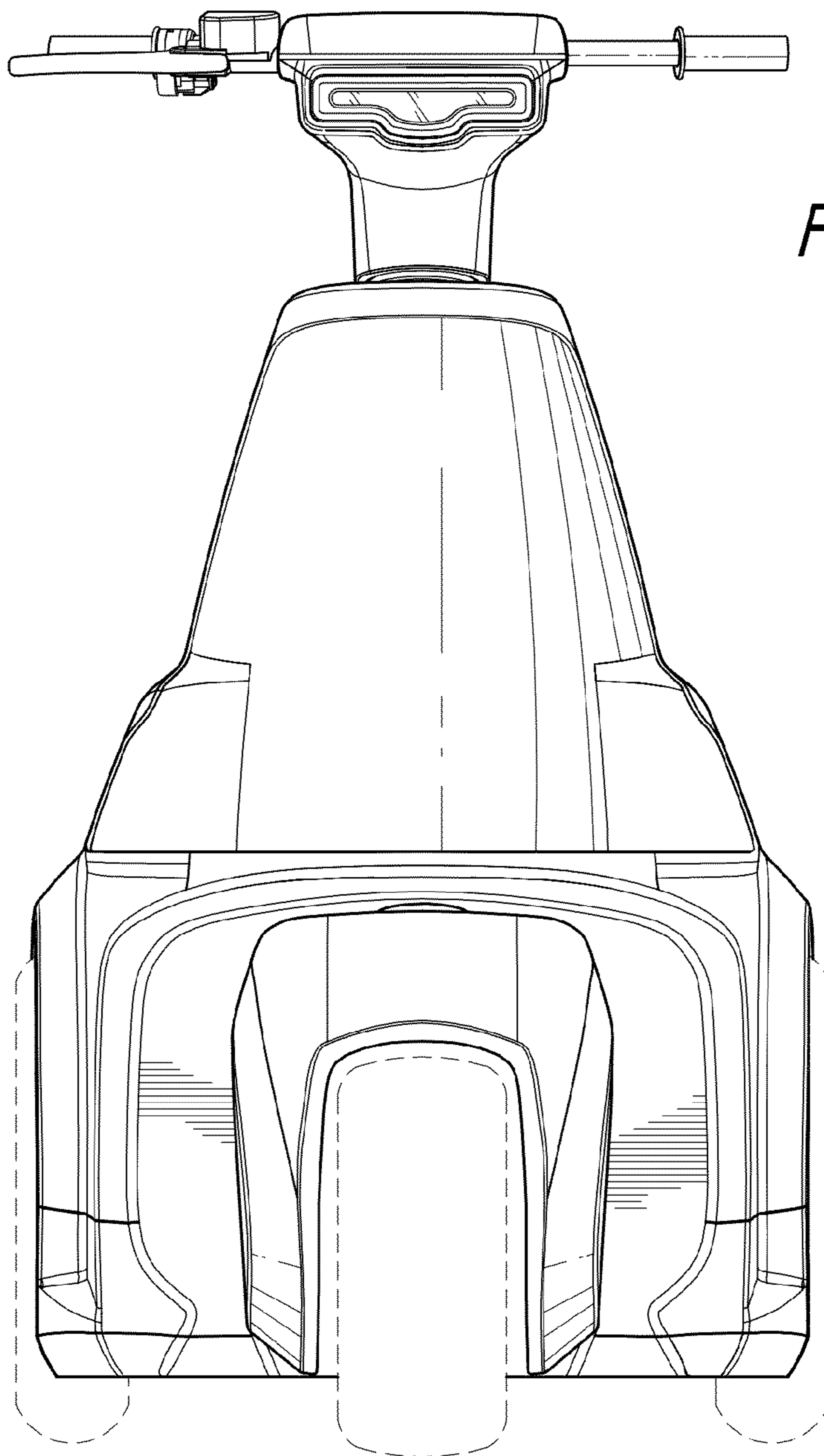
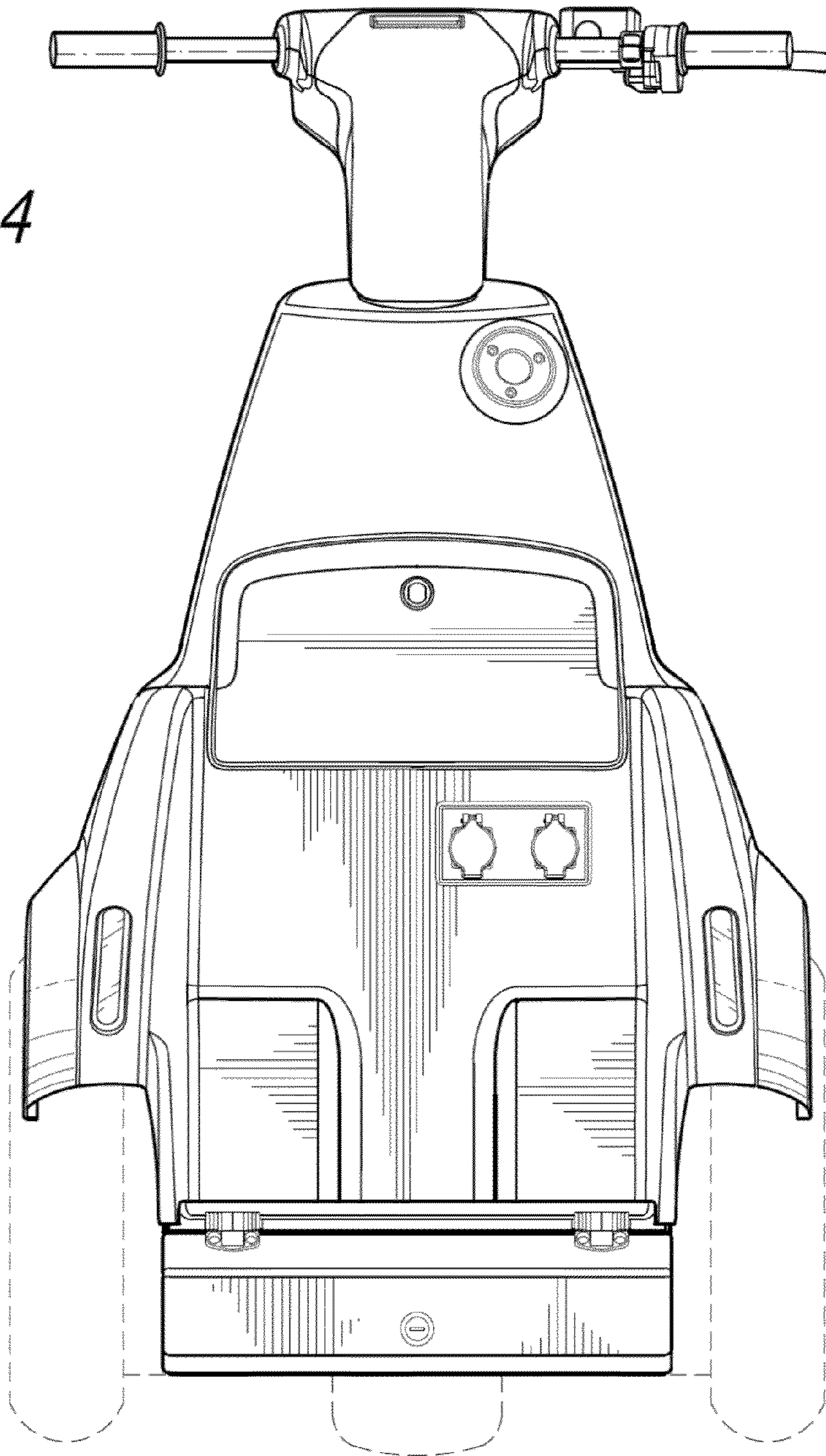


FIG. 2

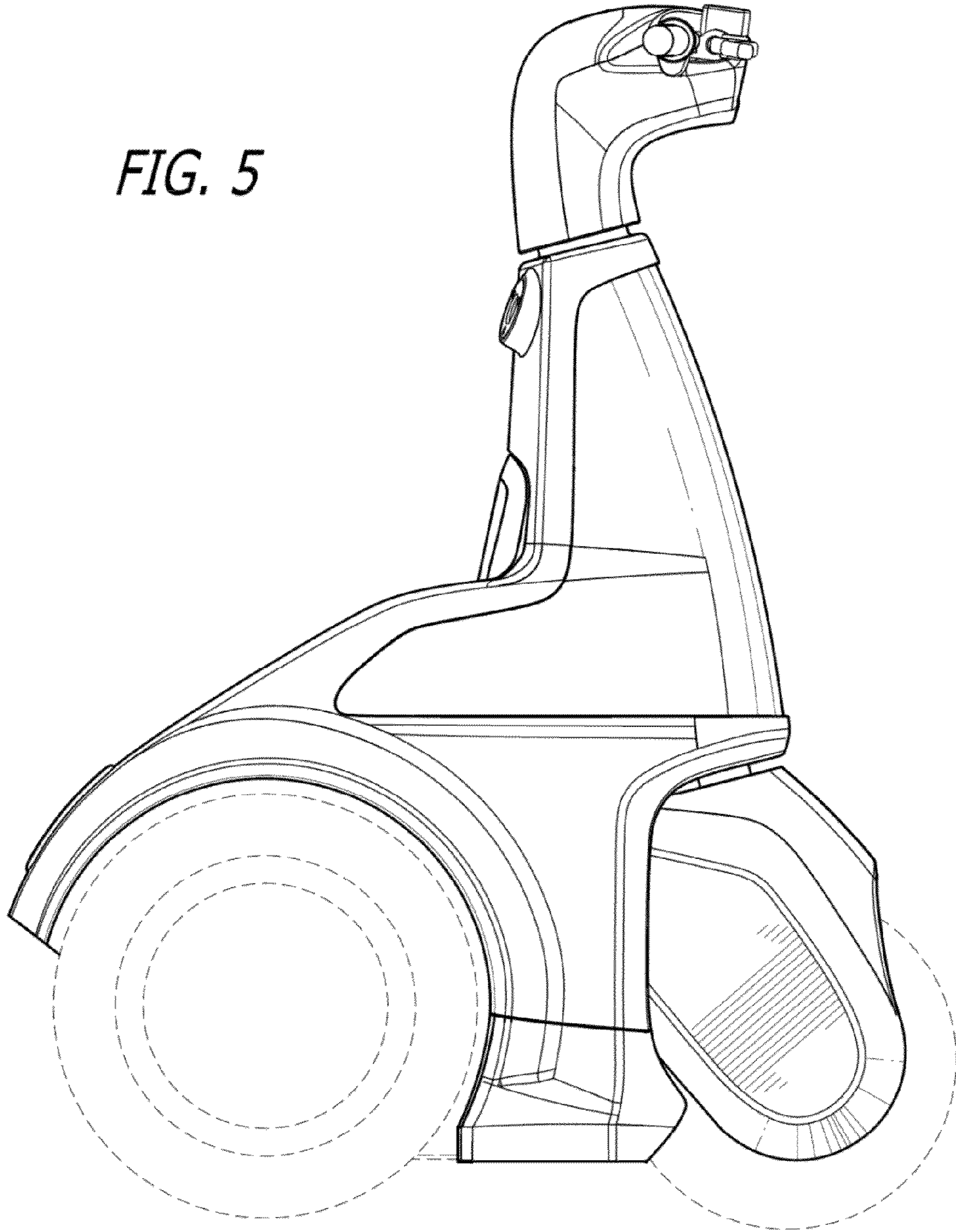


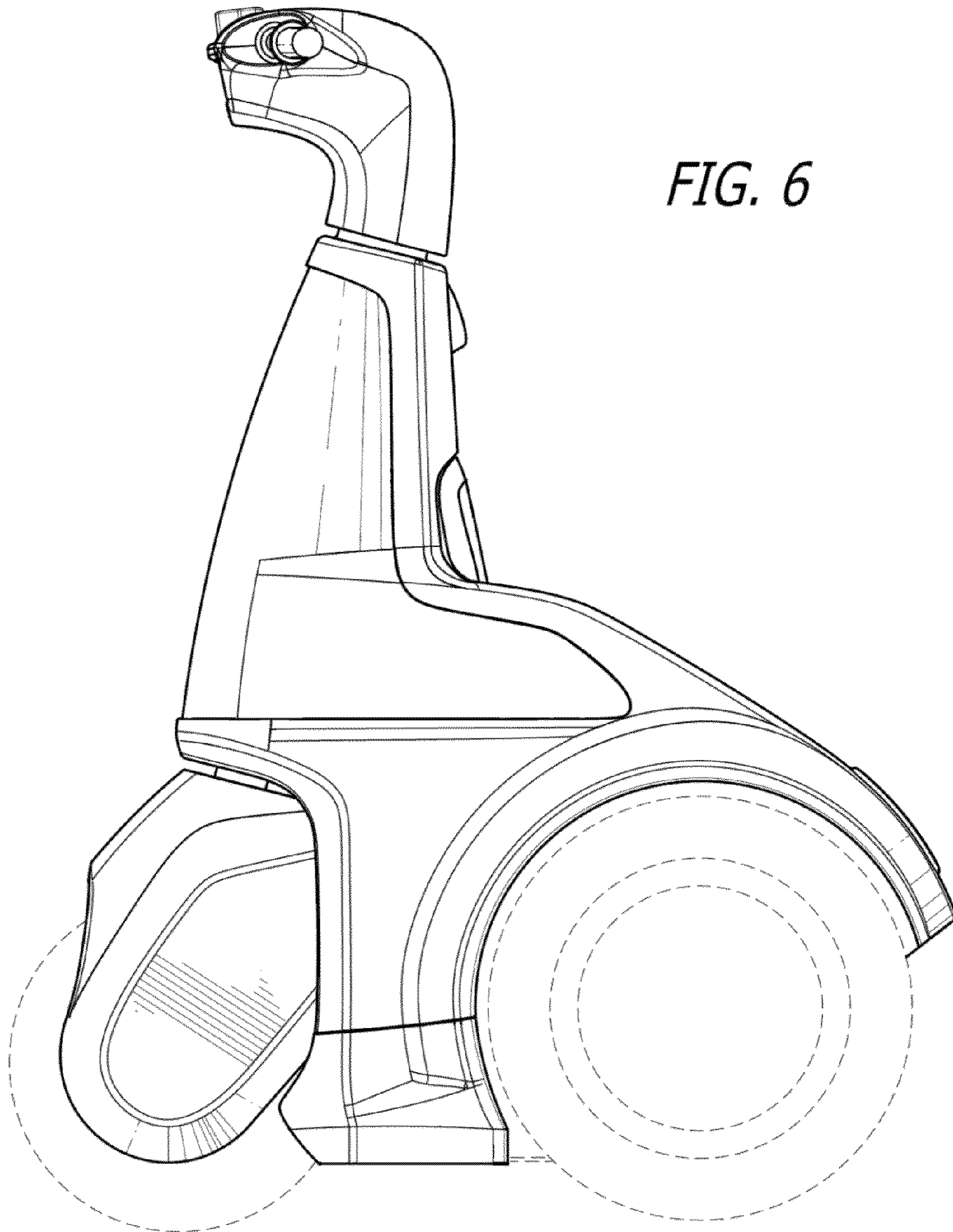
*FIG. 3*

*FIG. 4*



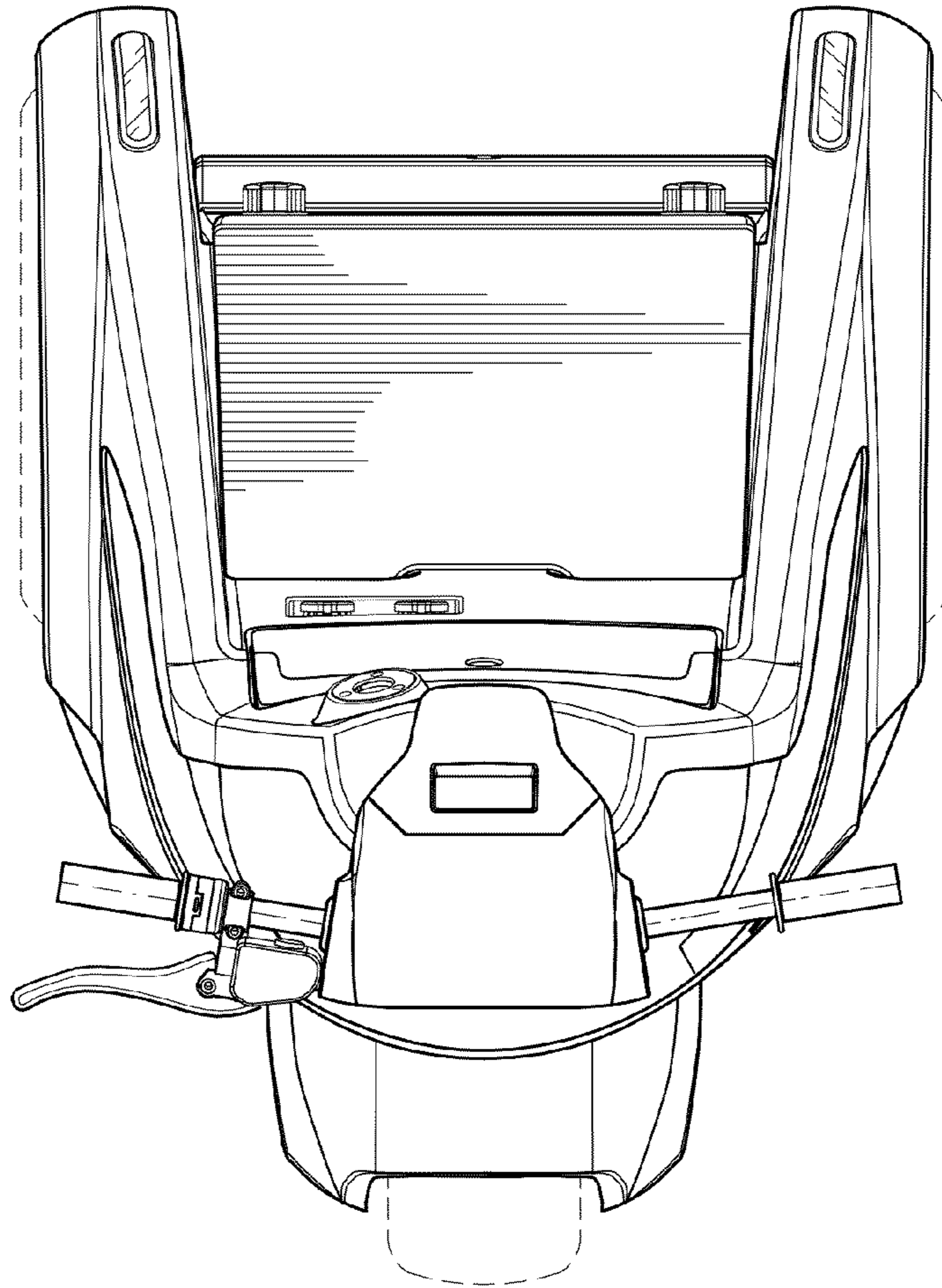
*FIG. 5*



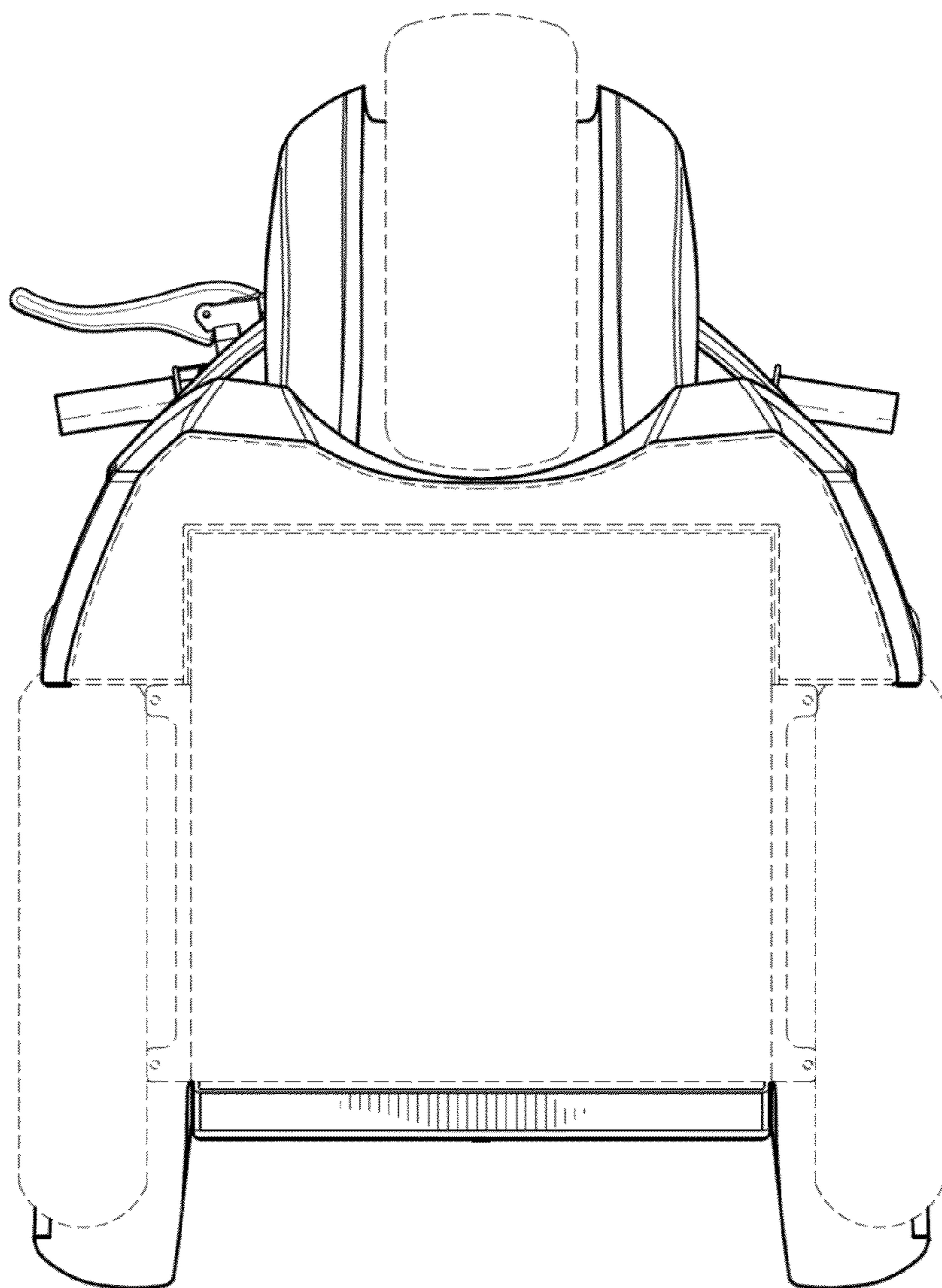


*FIG. 6*





*FIG. 7*



*FIG. 8*