



US00D735243S

(12) **United States Design Patent**
Nam et al.

(10) **Patent No.:** **US D735,243 S**

(45) **Date of Patent:** **** Jul. 28, 2015**

(54) **COVER OF COMPRESSOR FOR
AUTOMOBILES**

D668,679 S * 10/2012 Chen D15/9
D668,680 S * 10/2012 Chen D15/9
D673,179 S * 12/2012 Nam et al. D15/9
D673,180 S * 12/2012 Nam et al. D15/9

(71) Applicant: **GCS. INC., LTD**, Kimhae (KR)

* cited by examiner

(72) Inventors: **Taek Kyun Nam**, Pusan (KR); **Jung Ho Lee**, Kimhae-si (KR)

Primary Examiner — Ralf Seifert

(73) Assignee: **GCS Inc., Ltd.**, Kimhae (KR)

(74) *Attorney, Agent, or Firm* — Ladas & Parry LLP

(**) Term: **14 Years**

(57) **CLAIM**

We claim the ornamental design for a cover of compressor for automobiles, as shown and described.

(21) Appl. No.: **29/462,994**

DESCRIPTION

(22) Filed: **Aug. 12, 2013**

FIG. 1 is a front perspective view of cover of compressor for automobiles showing our new design;

(30) **Foreign Application Priority Data**

Feb. 14, 2013 (KR) 30-2013-0007802

FIG. 2 is a front-side elevational view thereof;

(51) **LOC (10) Cl.** **05-02**

FIG. 3 is a rear-side elevational view thereof;

(52) **U.S. Cl.**
USPC **D15/9**

FIG. 4 is a left-side elevational view thereof;

(58) **Field of Classification Search**
USPC D15/7-9; D23/231, 232, 225; 417/60,
417/235, 265, 321, 355, 358, 363, 359,
417/410.1, 415-416, 405, 900; 60/408,
60/412; 184/26-37; 415/140-147;
123/495, 509

FIG. 5 is a right-side elevational view thereof;

CPC F04B 39/00; F04B 1/12; F04B 11/00;
F04B 39/12; F01N 7/10

FIG. 6 is a top-side elevational view thereof;

See application file for complete search history.

FIG. 7 is a bottom-side elevational view thereof;

FIG. 8 is a rear perspective view thereof;

FIG. 9 is a front perspective view of another embodiment of a cover of compressor for automobiles showing our new design;

FIG. 10 is a front-side elevational view thereof;

FIG. 11 is a rear-side elevational view thereof;

FIG. 12 is a left-side elevational view thereof;

FIG. 13 is a right-side elevational view thereof;

FIG. 14 is a top-side elevational view thereof;

FIG. 15 is a bottom-side elevational view thereof; and,

FIG. 16 is a rear perspective view thereof.

The broken lines shown in the drawings represent unclaimed portions of the cover of compressor for automobiles.

(56) **References Cited**

U.S. PATENT DOCUMENTS

D668,677 S * 10/2012 Chen D15/9
D668,678 S * 10/2012 Chen D15/9

1 Claim, 16 Drawing Sheets

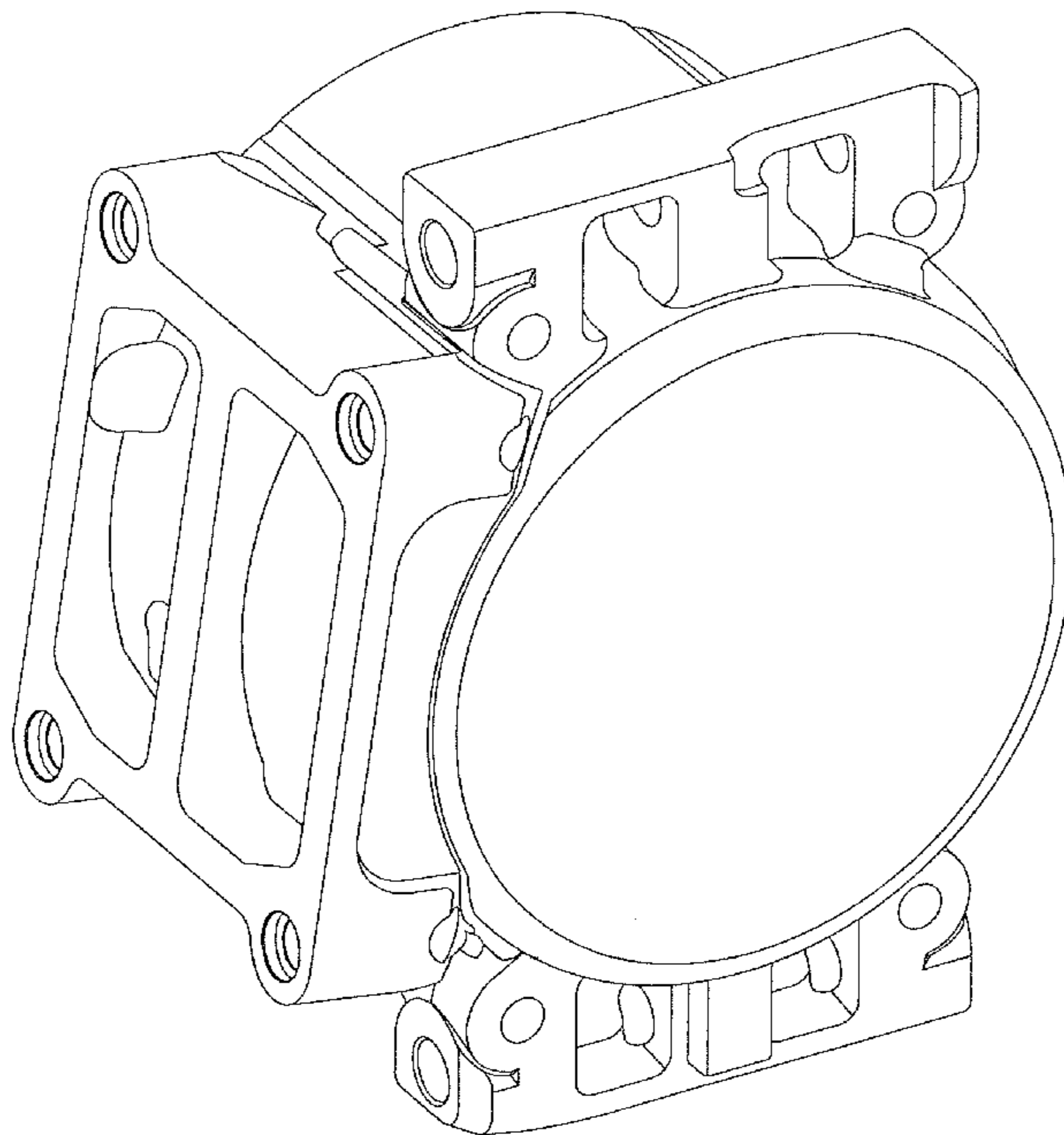

FIG. 1

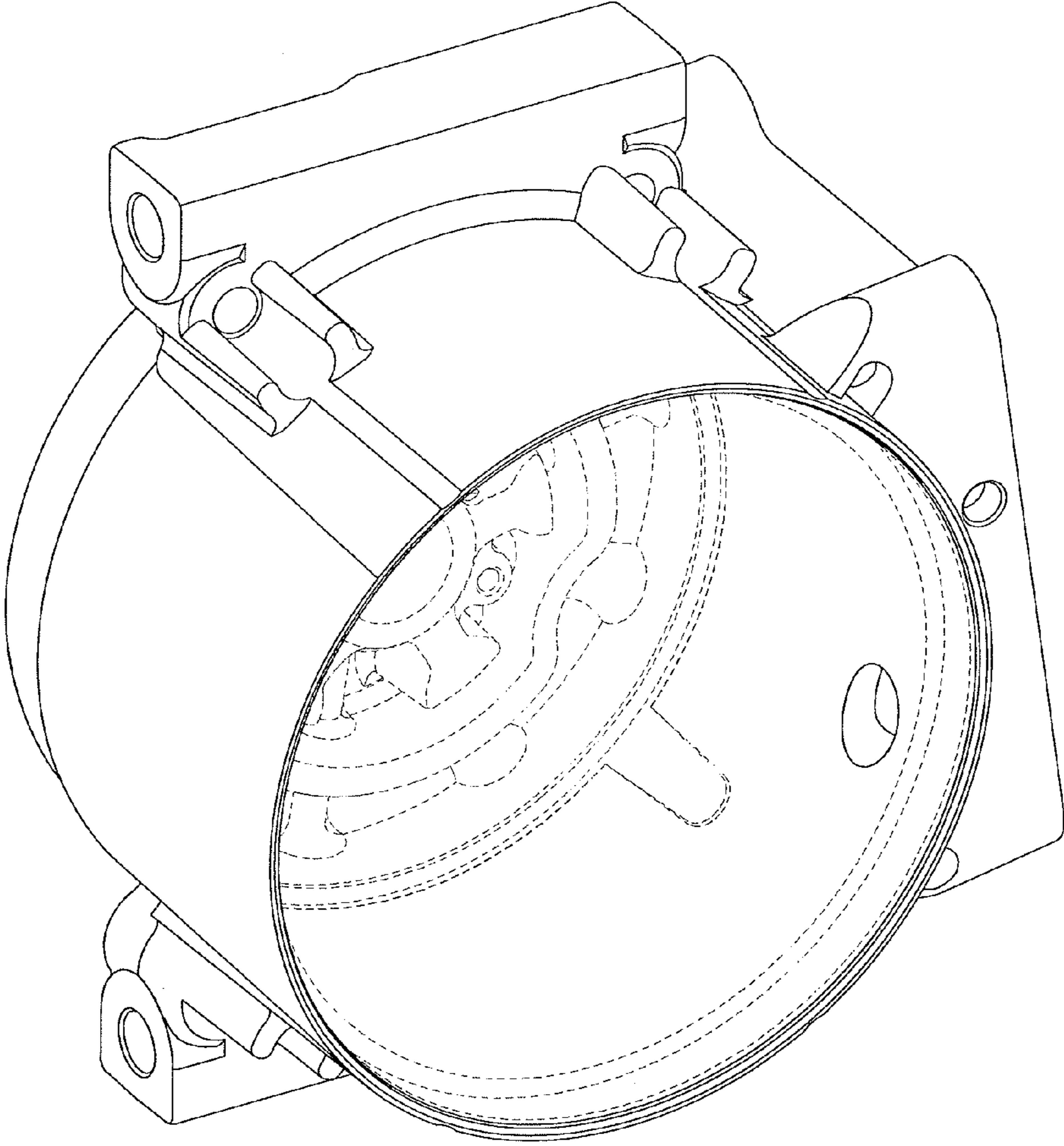

FIG. 2

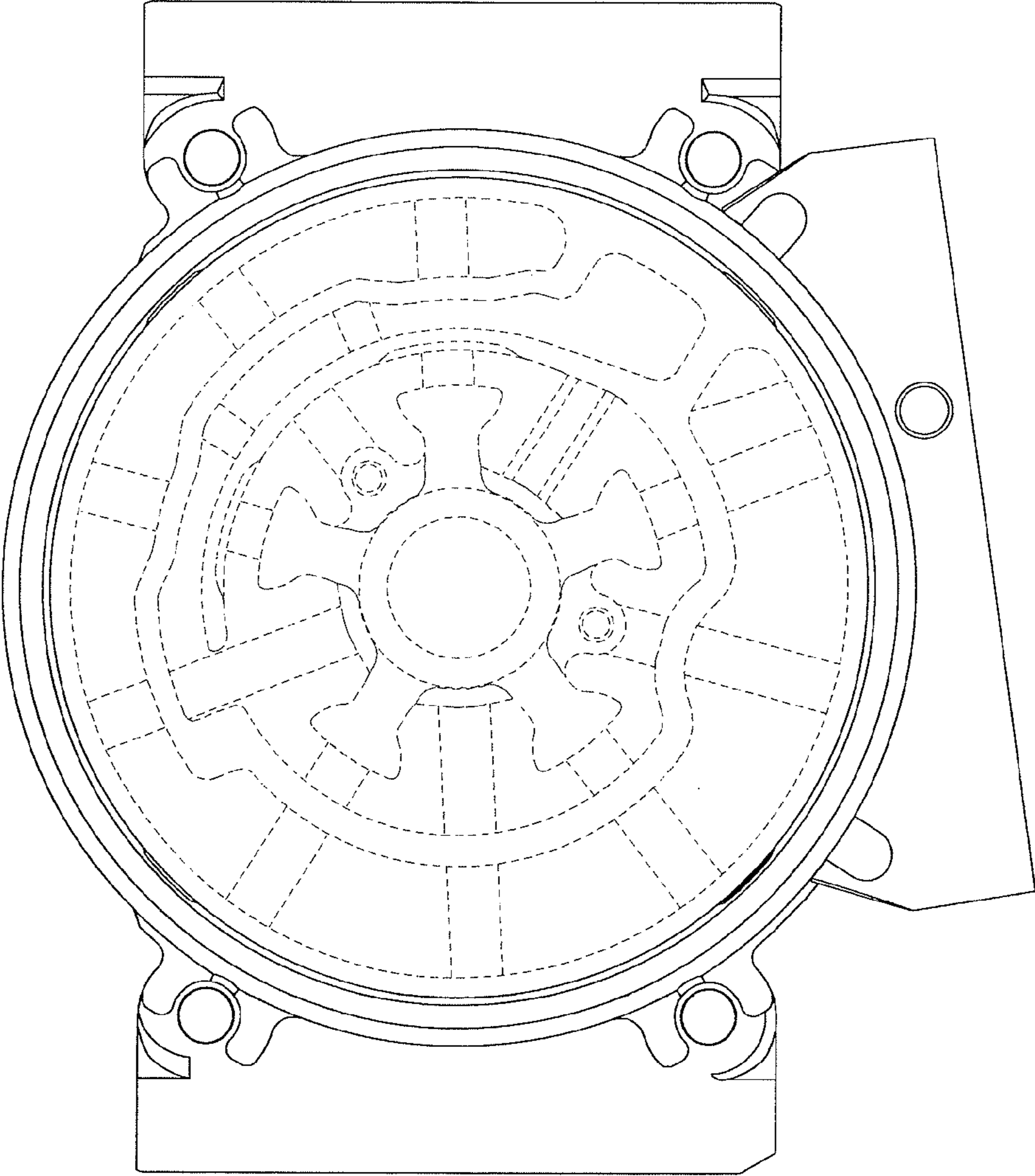

FIG. 3

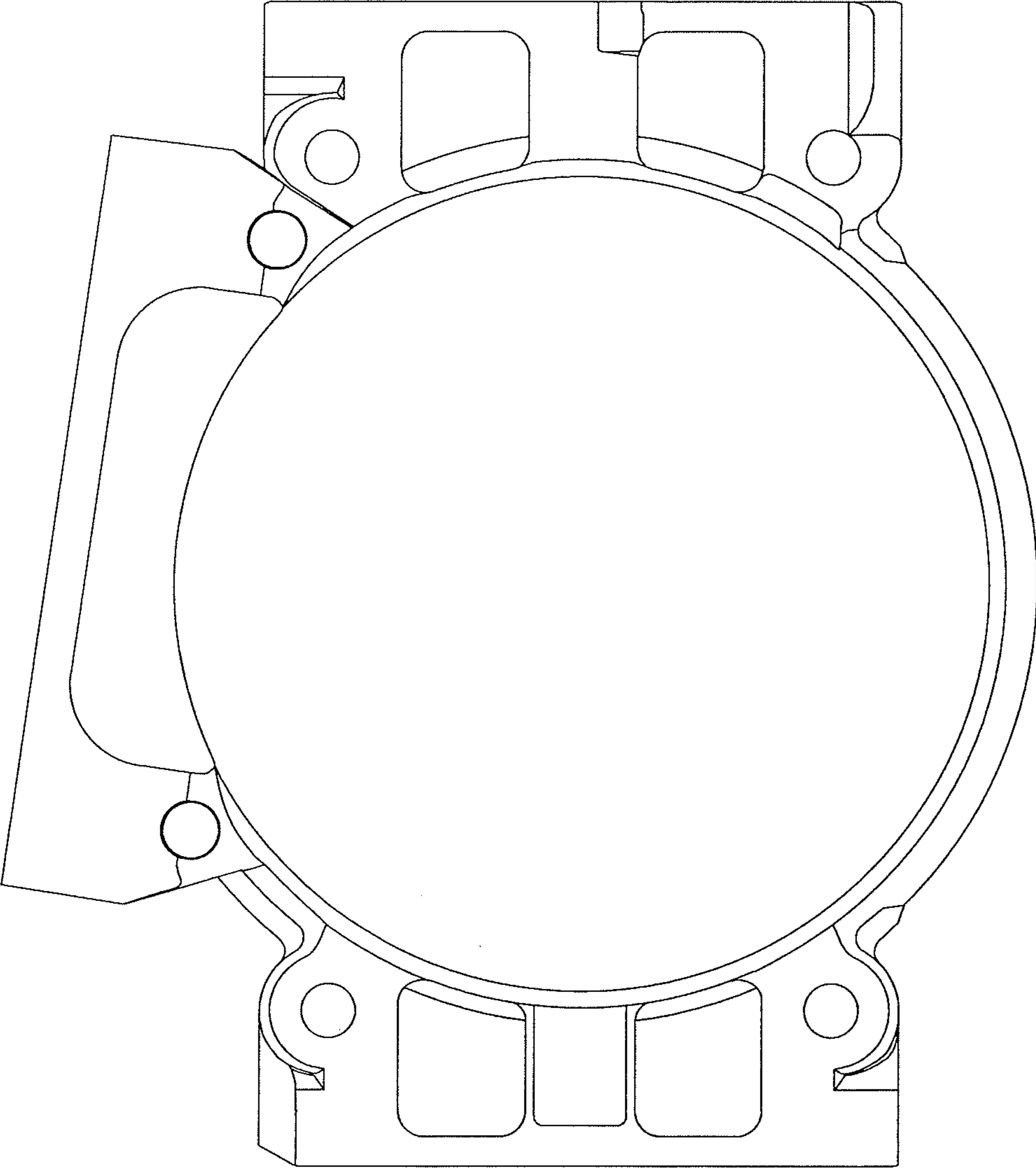

FIG. 4

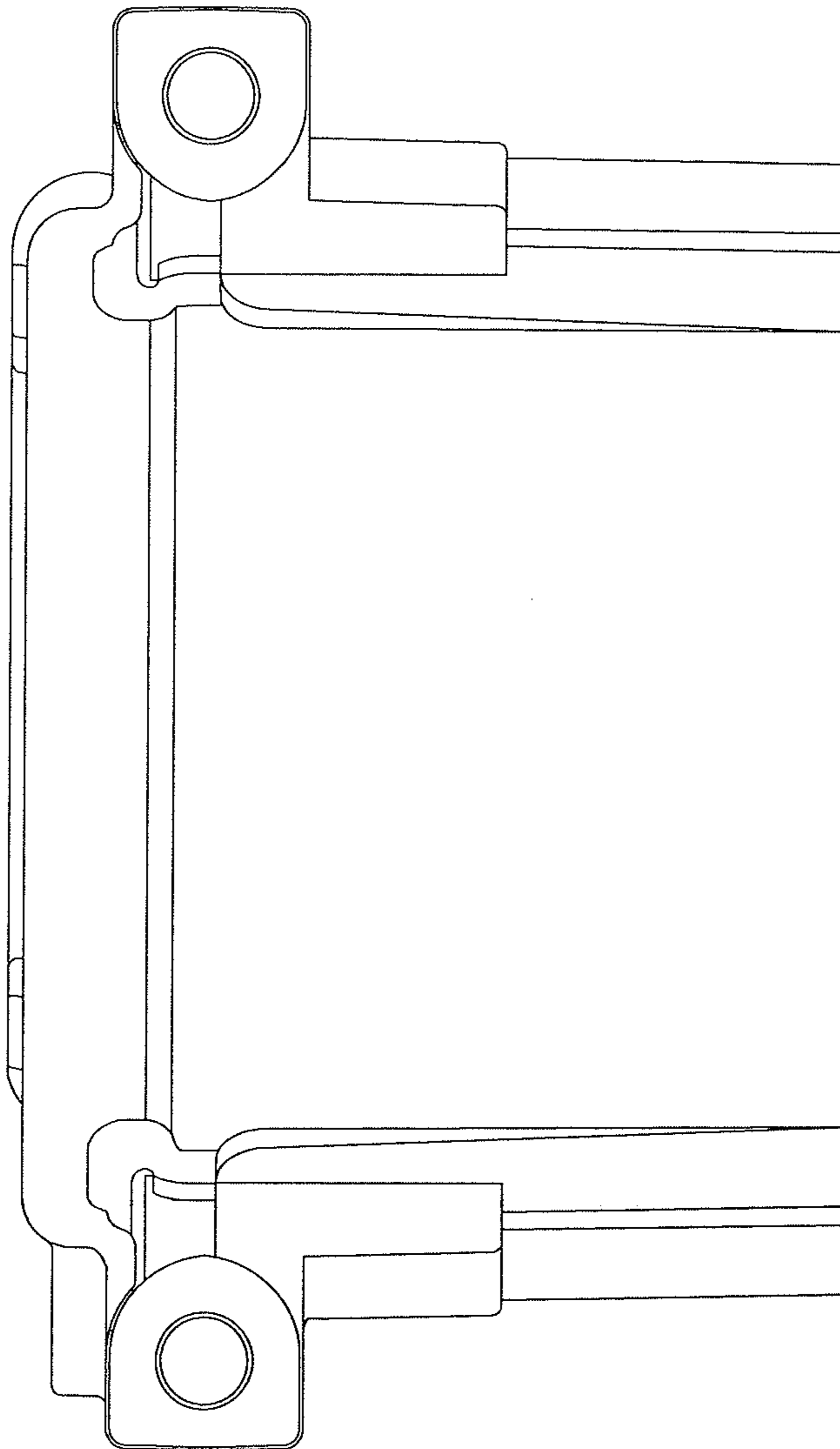

FIG. 5

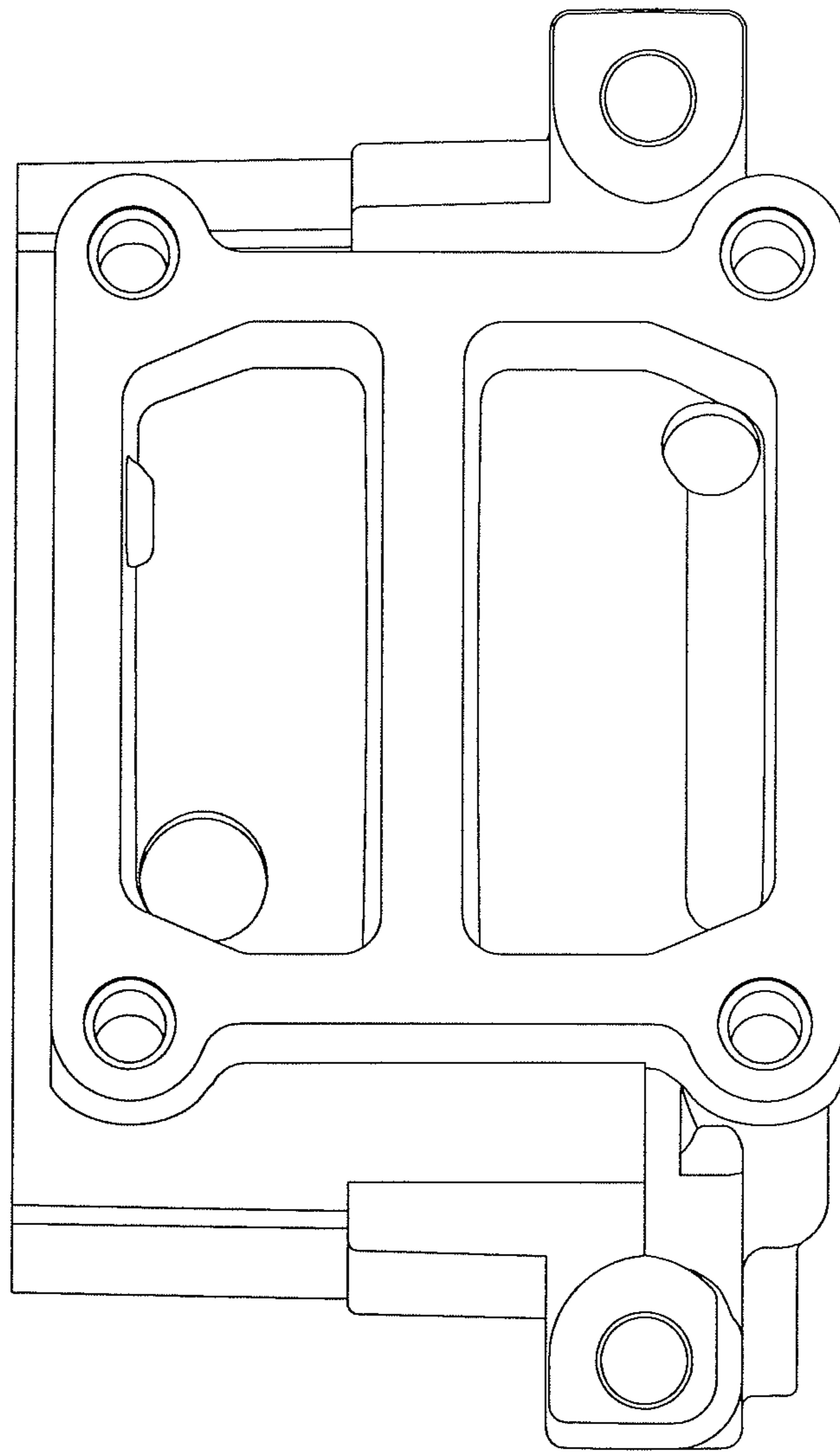

FIG. 6

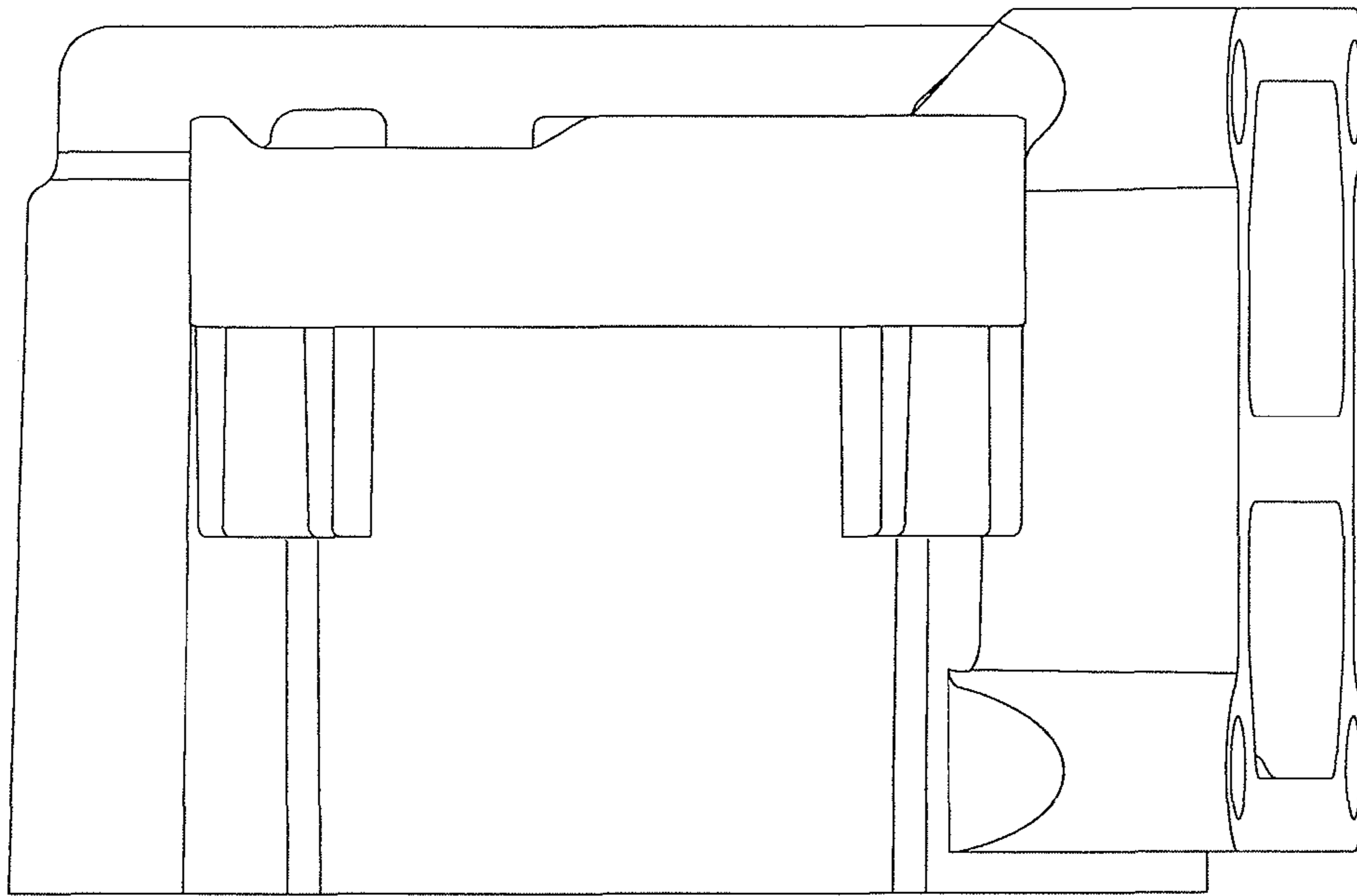

FIG. 7

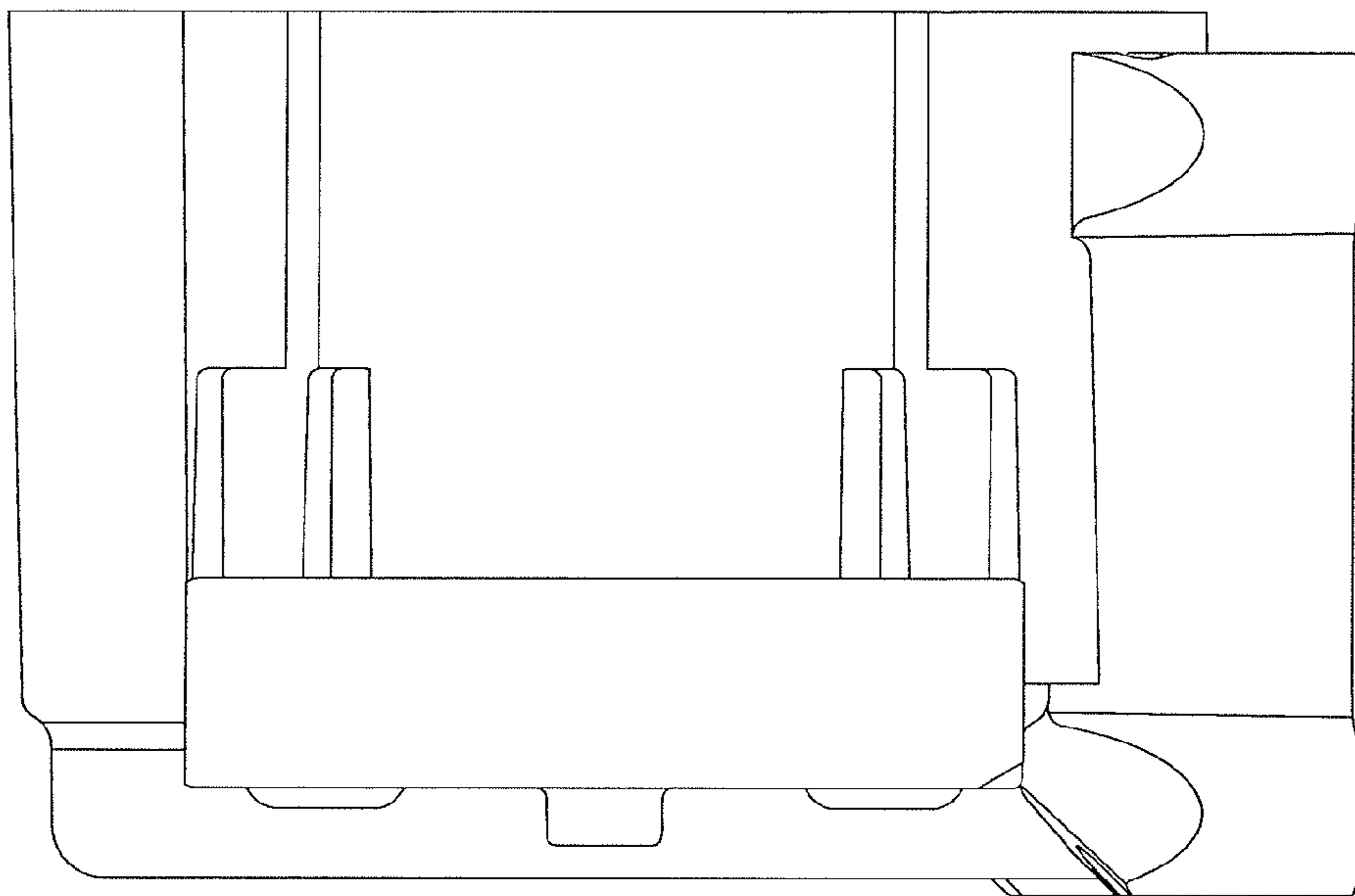

FIG. 8

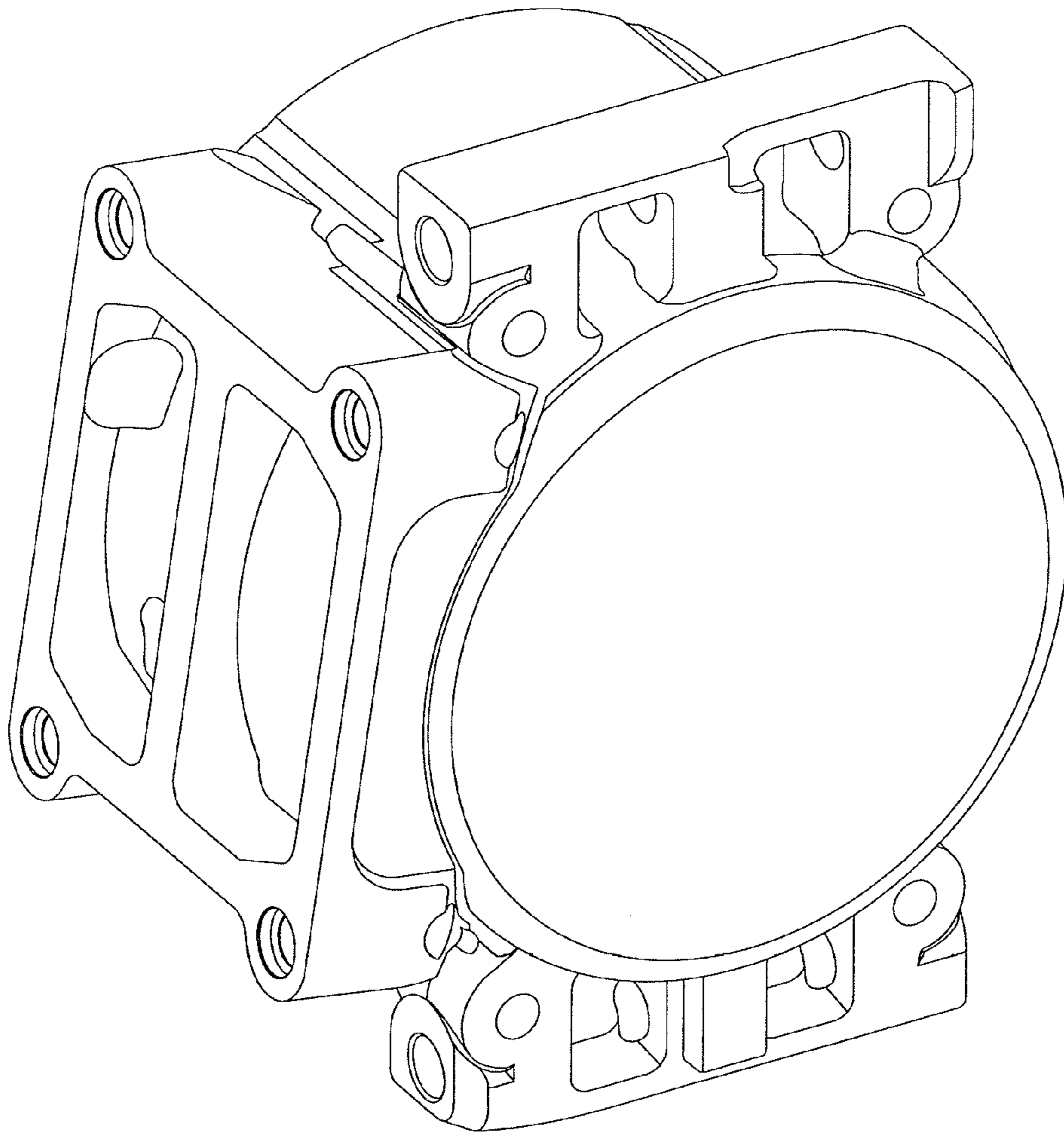

FIG. 9

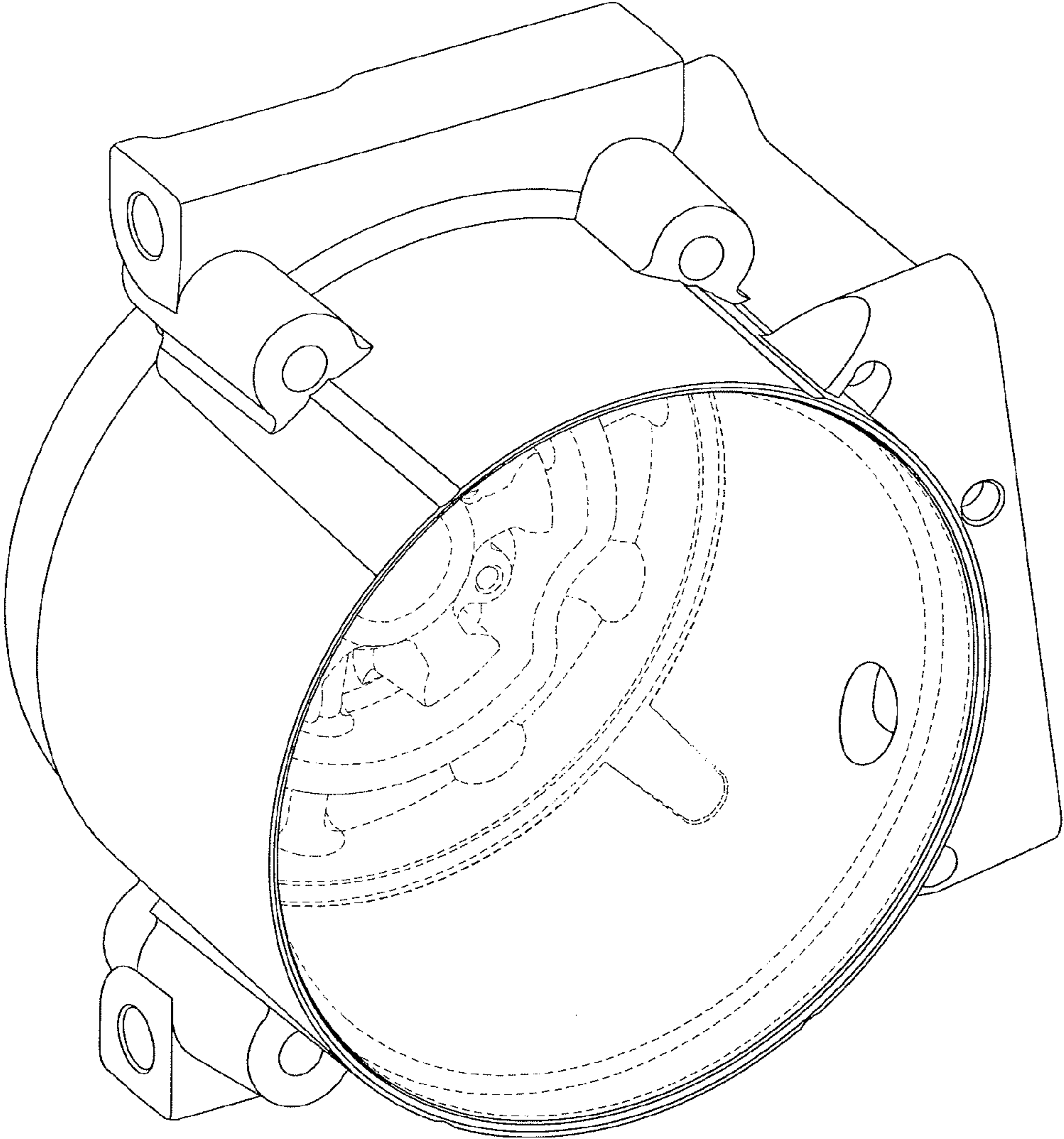

FIG. 10

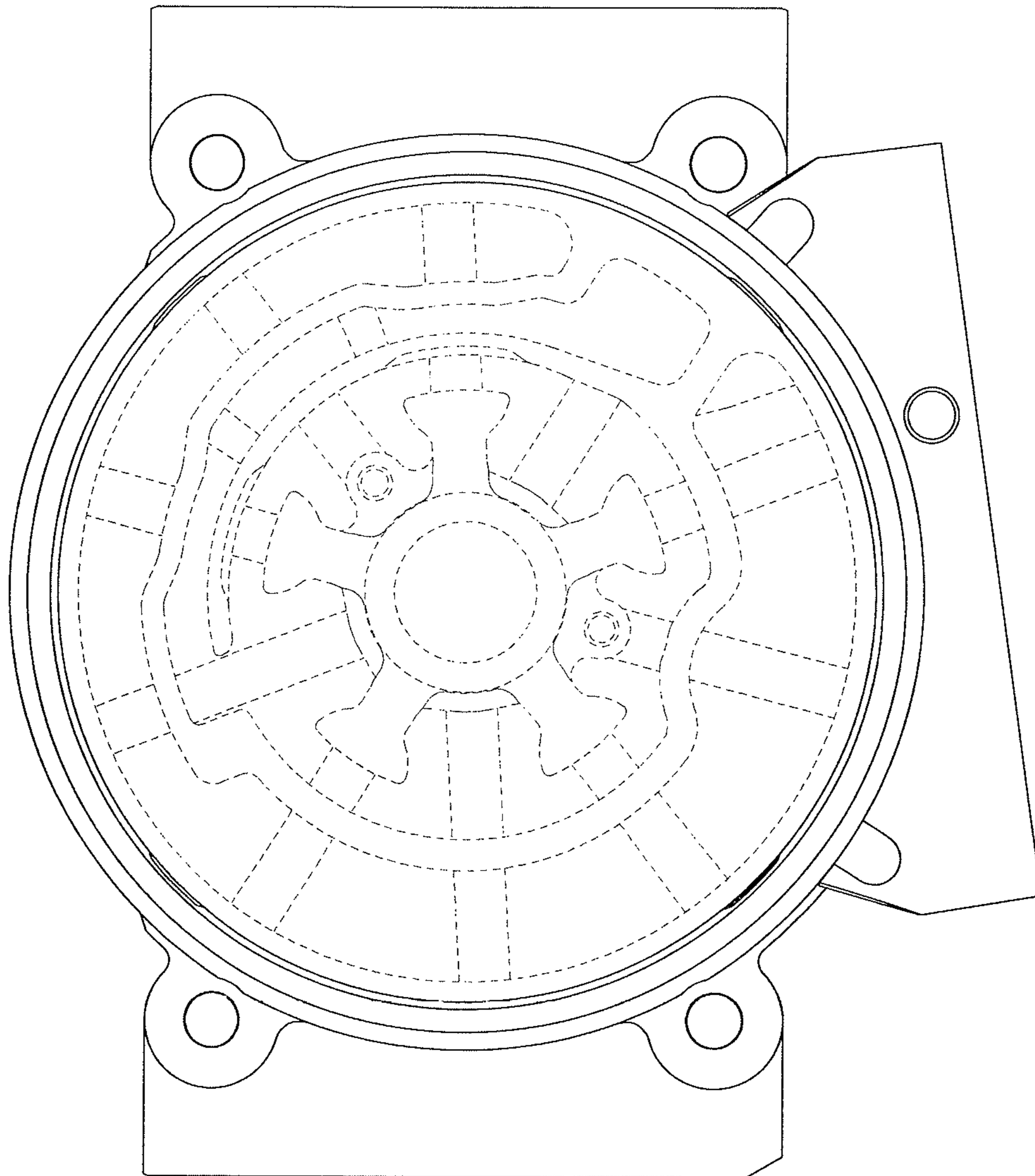

FIG. 11

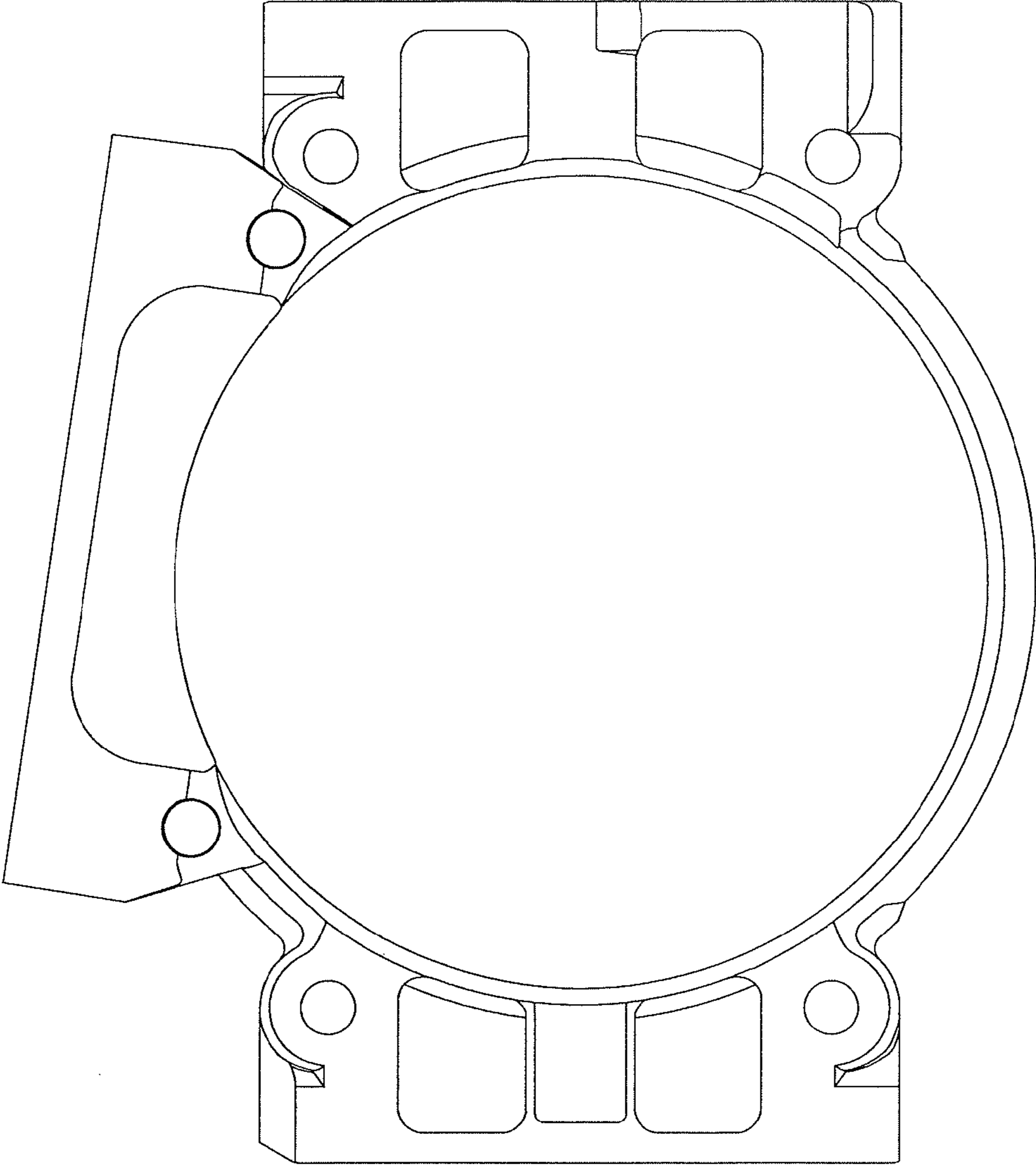

FIG. 12

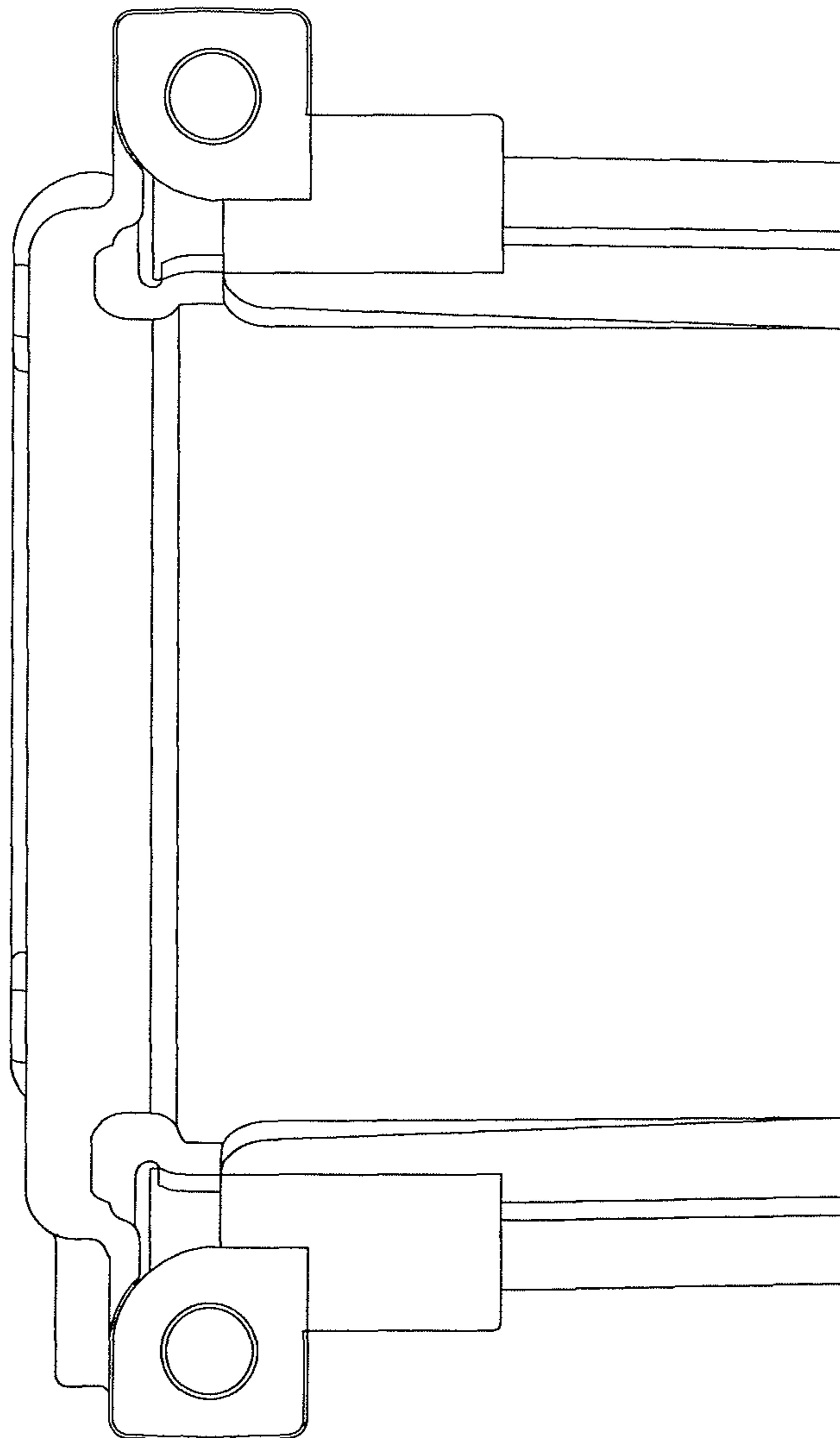

FIG. 13

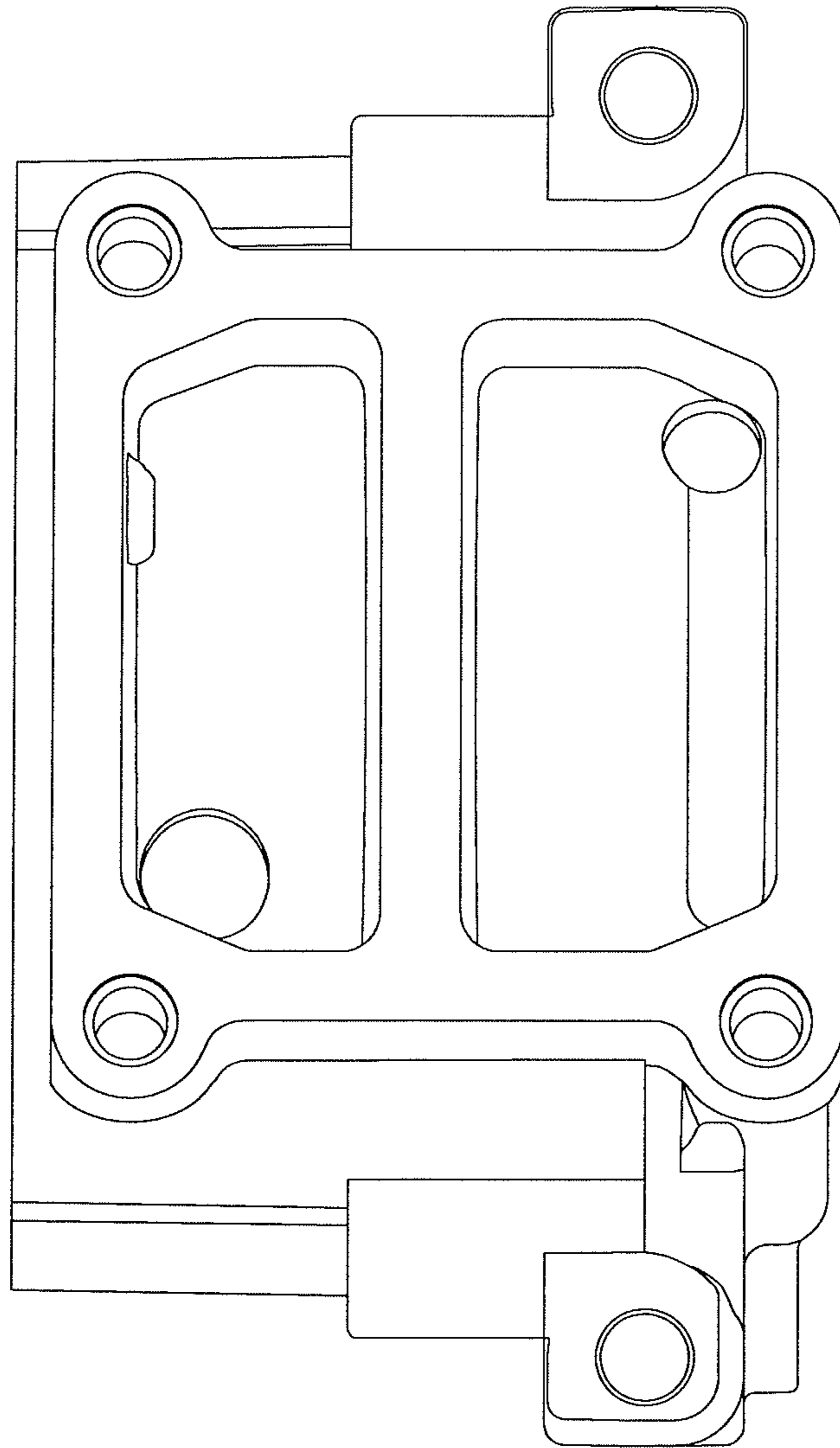

FIG. 14

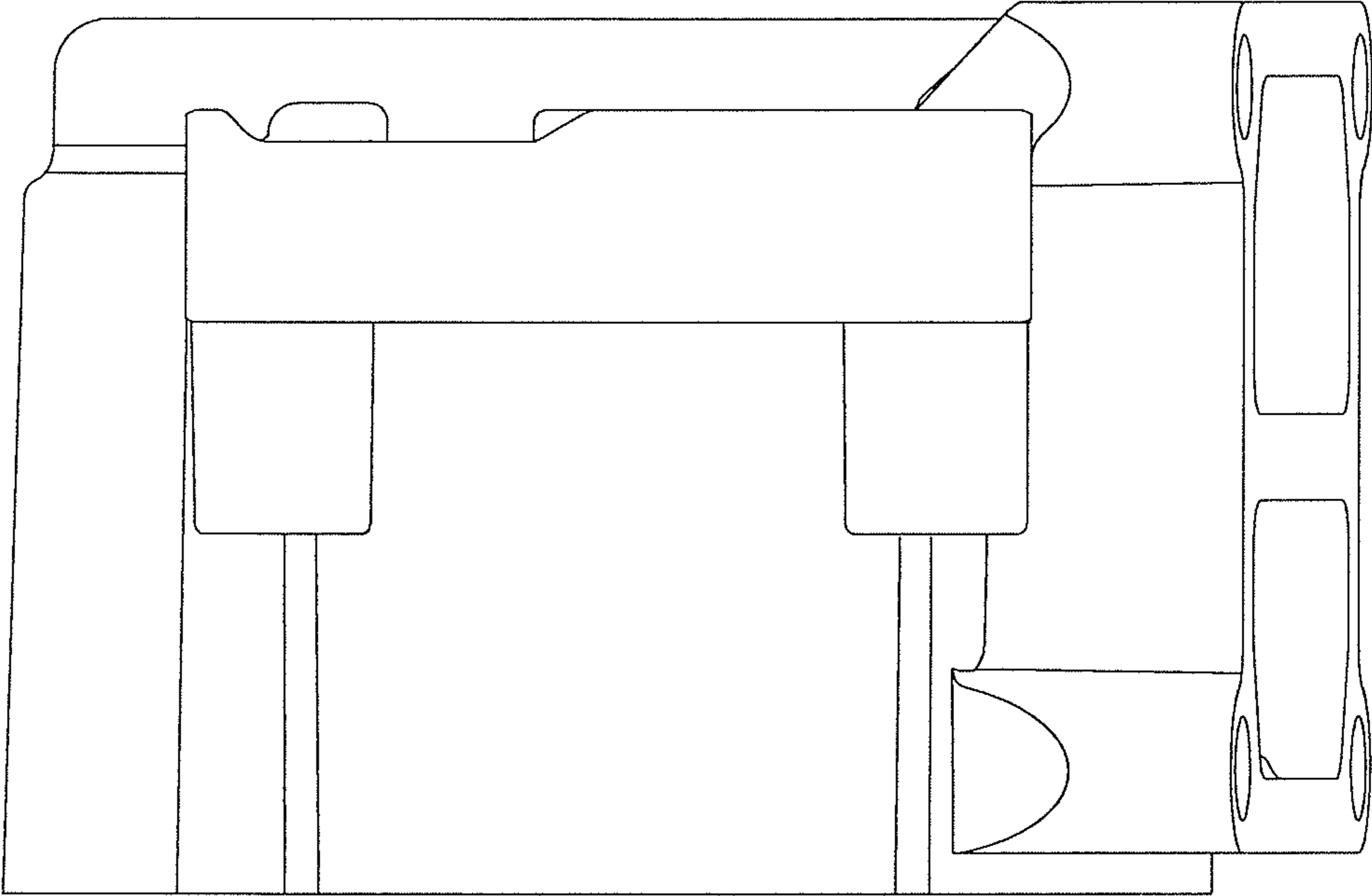

FIG. 15

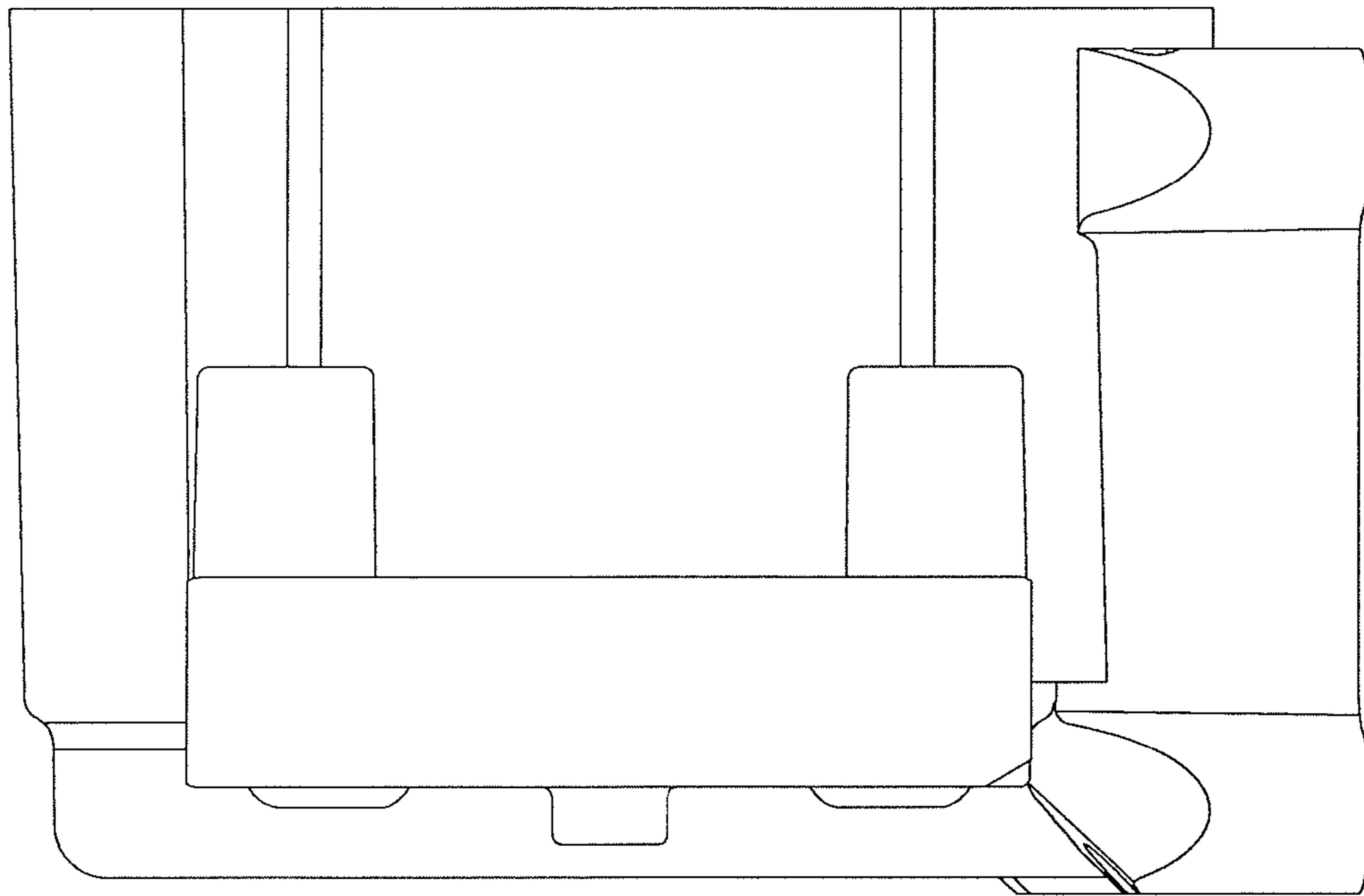

FIG. 16

