



US00D734781S

(12) **United States Design Patent**
Schnering et al.

(10) **Patent No.:** **US D734,781 S**

(45) **Date of Patent:** **** Jul. 21, 2015**

(54) **WORK VEHICLE CABIN**

(71) Applicant: **DEERE & COMPANY**, Moline, IL
(US)

(72) Inventors: **Jodi L. Schnering**, Platteville, WI (US);
Charles J. Asp, Epworth, IA (US);
Michael J. Dejung, Sebastopol, CA
(US); **Thomas H. Ward**, Ventura, CA
(US)

(73) Assignee: **Deere & Company**, Moline, IL (US)

(**) Term: **14 Years**

(21) Appl. No.: **29/481,777**

(22) Filed: **Feb. 10, 2014**

(51) **LOC (10) Cl.** **15-03**

(52) **U.S. Cl.**
USPC **D15/30**

(58) **Field of Classification Search**
USPC D15/28-33; D12/99, 96; 180/89.12,
180/89.13, 89.16, 89.18, 89.19;
296/190.01, 190.04, 190.08

See application file for complete search history.

(56) **References Cited**

U.S. PATENT DOCUMENTS

D275,199	S	*	8/1984	Schmidt et al.	D15/30
D636,795	S	*	4/2011	Yamamoto et al.	D15/30
D667,851	S	*	9/2012	Warr	D15/30
D670,745	S	*	11/2012	Warr	D15/30
D686,643	S	*	7/2013	Kinoshita et al.	D15/30
D698,831	S	*	2/2014	Adamson et al.	D15/28

* cited by examiner

Primary Examiner — Robin V Webster

(74) *Attorney, Agent, or Firm* — Quarles & Brady LLP

(57) **CLAIM**

The ornamental design for a work vehicle cabin, as shown and described.

DESCRIPTION

FIG. 1 is a top, front, right perspective view of a work vehicle cabin showing our new design with exemplary work vehicle environment;

FIG. 2 is a top, front, right perspective view thereof;

FIG. 3 is a front end view thereof;

FIG. 4 is a rear end view thereof;

FIG. 5 is a right side elevational view thereof;

FIG. 6 is a left side elevational view thereof; and,

FIG. 7 is a top plan view thereof.

The broken line representations in the figures, including the broken line work vehicle environment shown in FIGS. 1 and 7, show unclaimed environment or boundaries, and thus form no part of the claimed design.

1 Claim, 7 Drawing Sheets

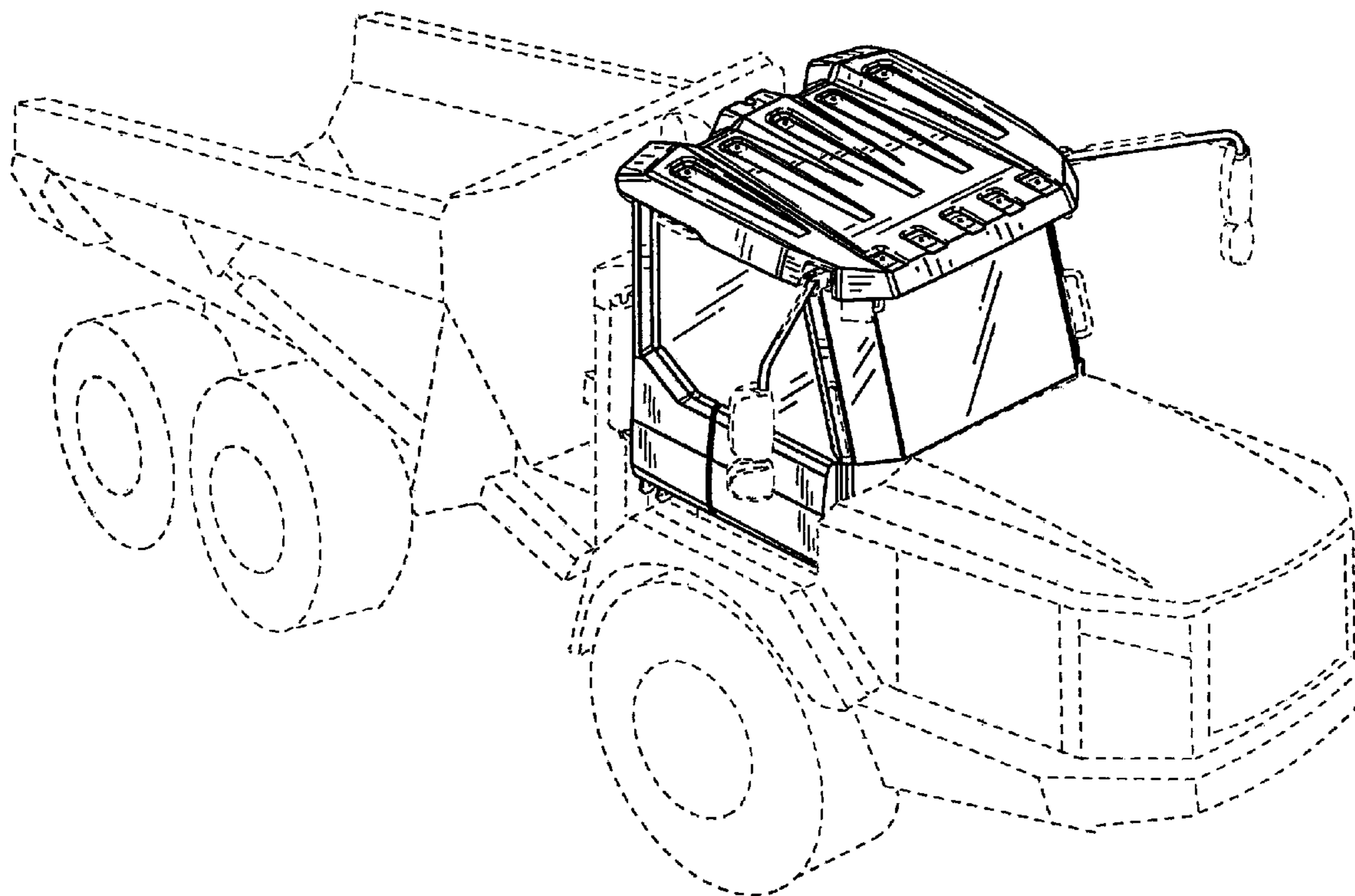

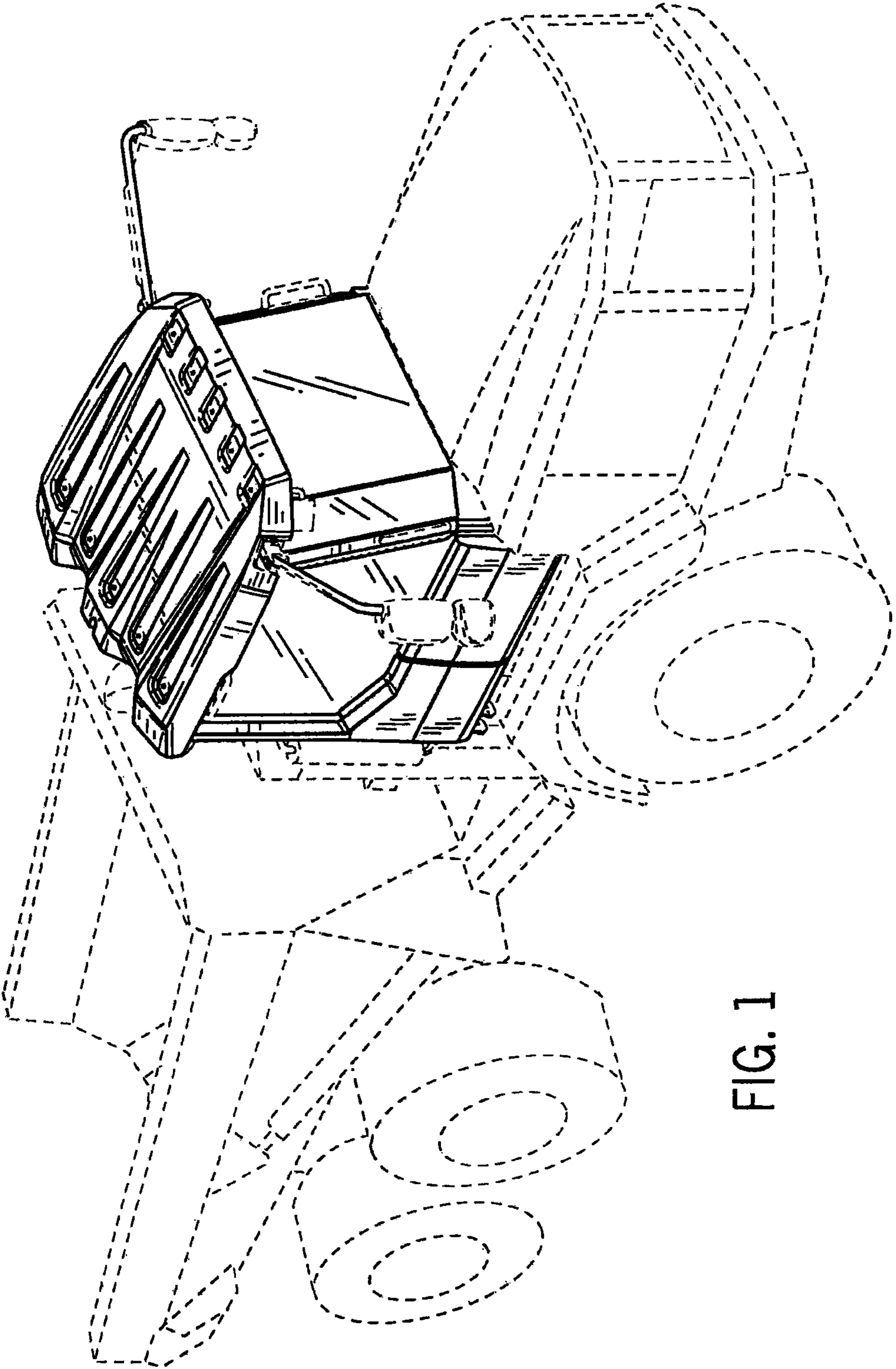

FIG. 1

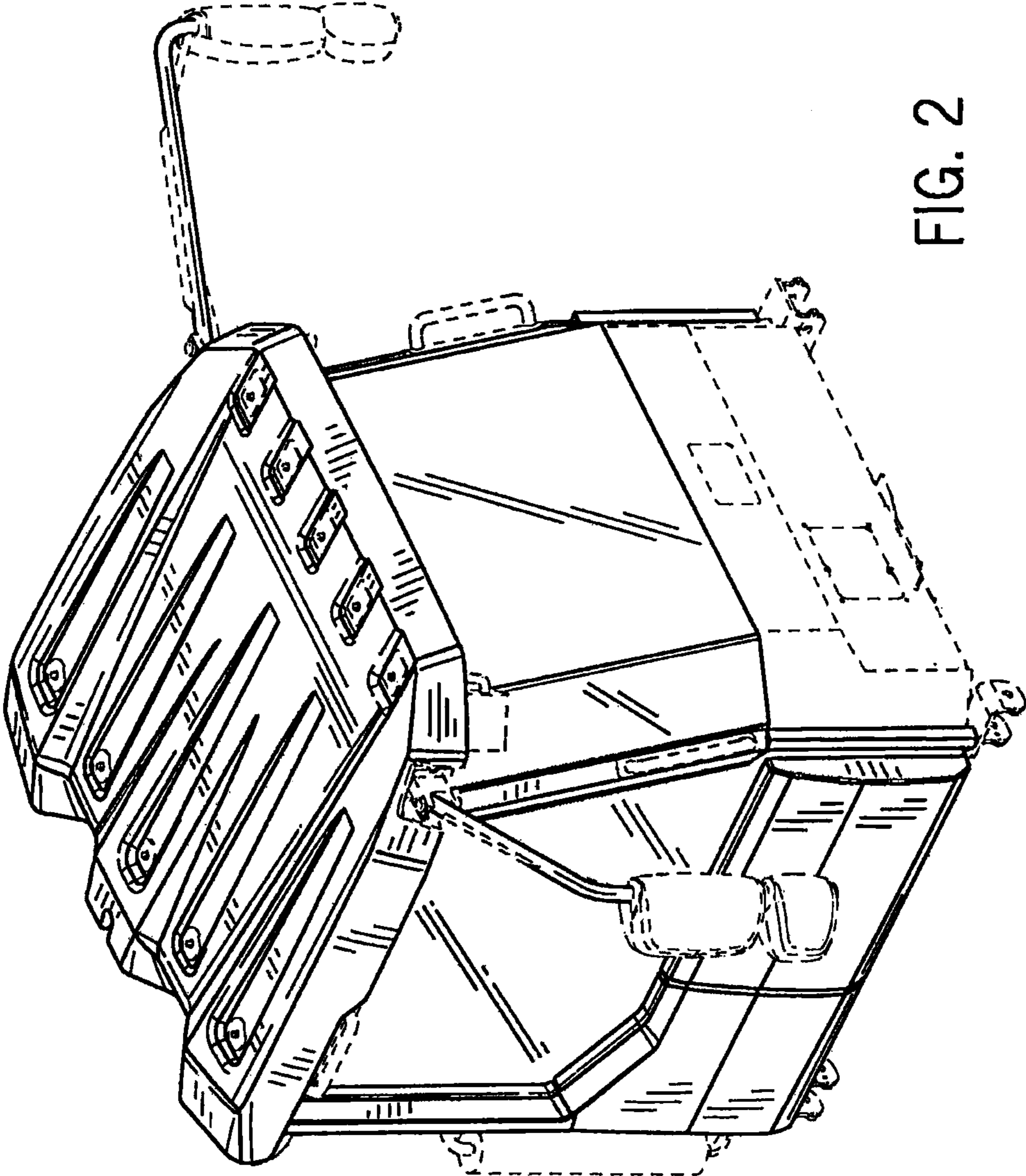

FIG. 2

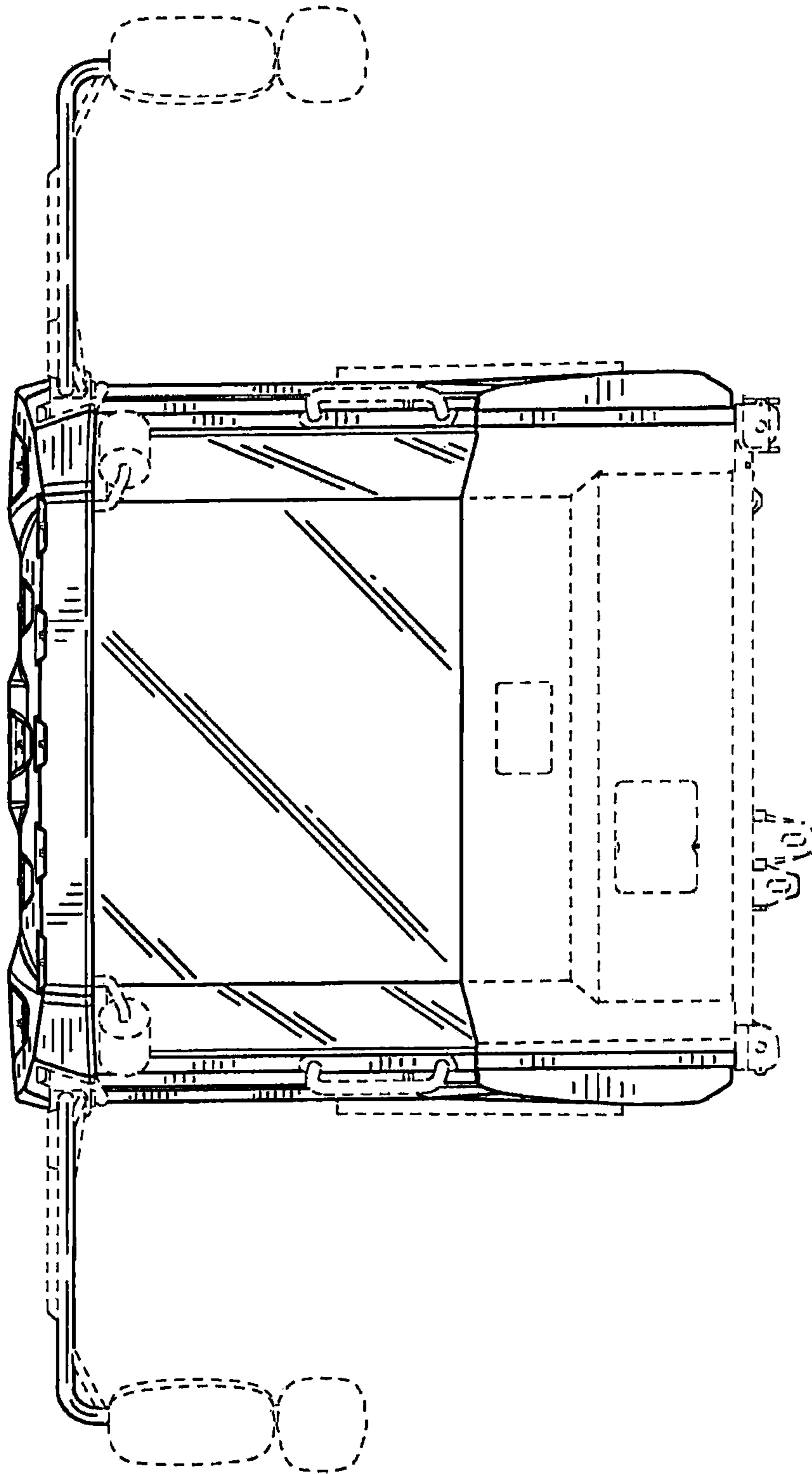

FIG. 3

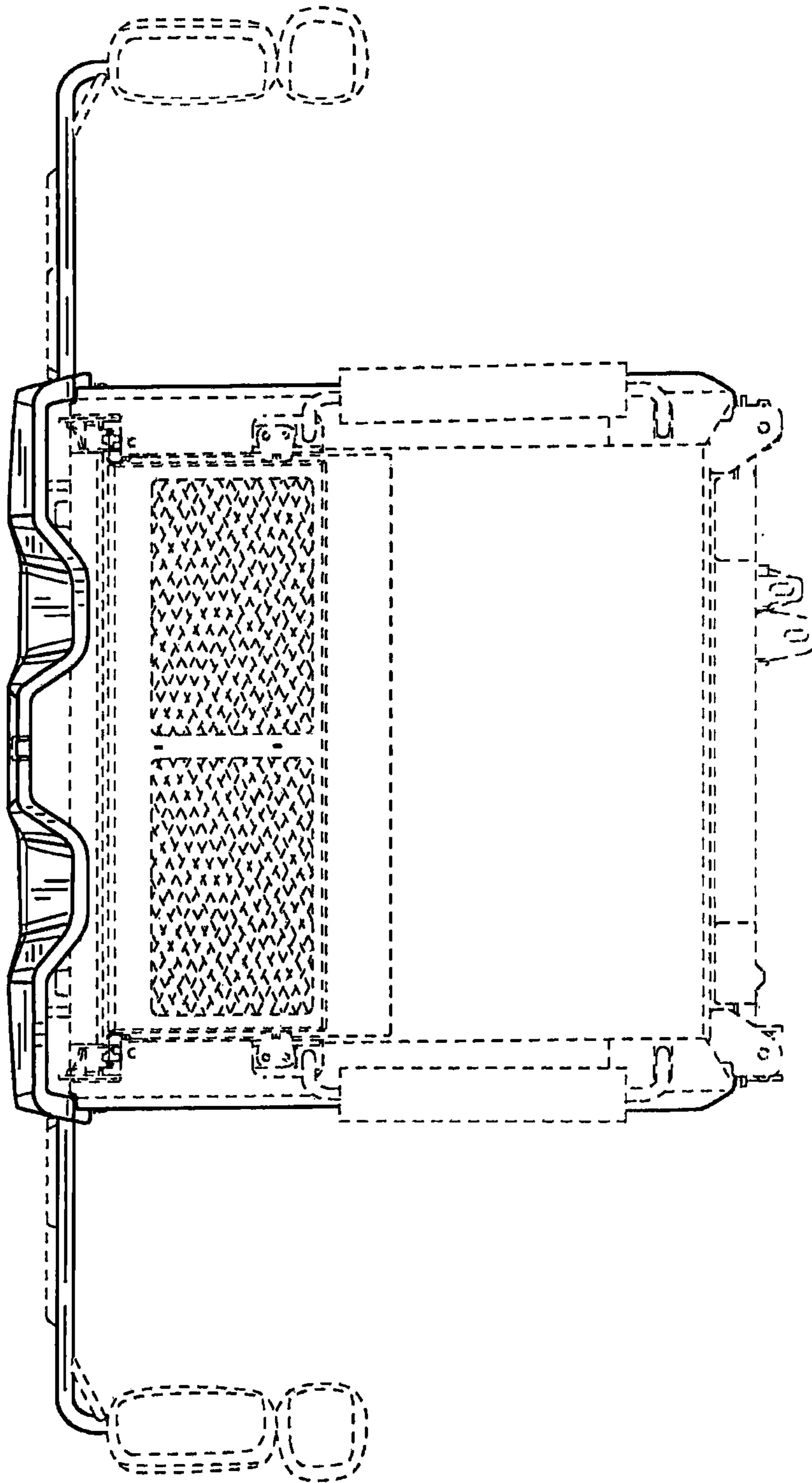

FIG. 4

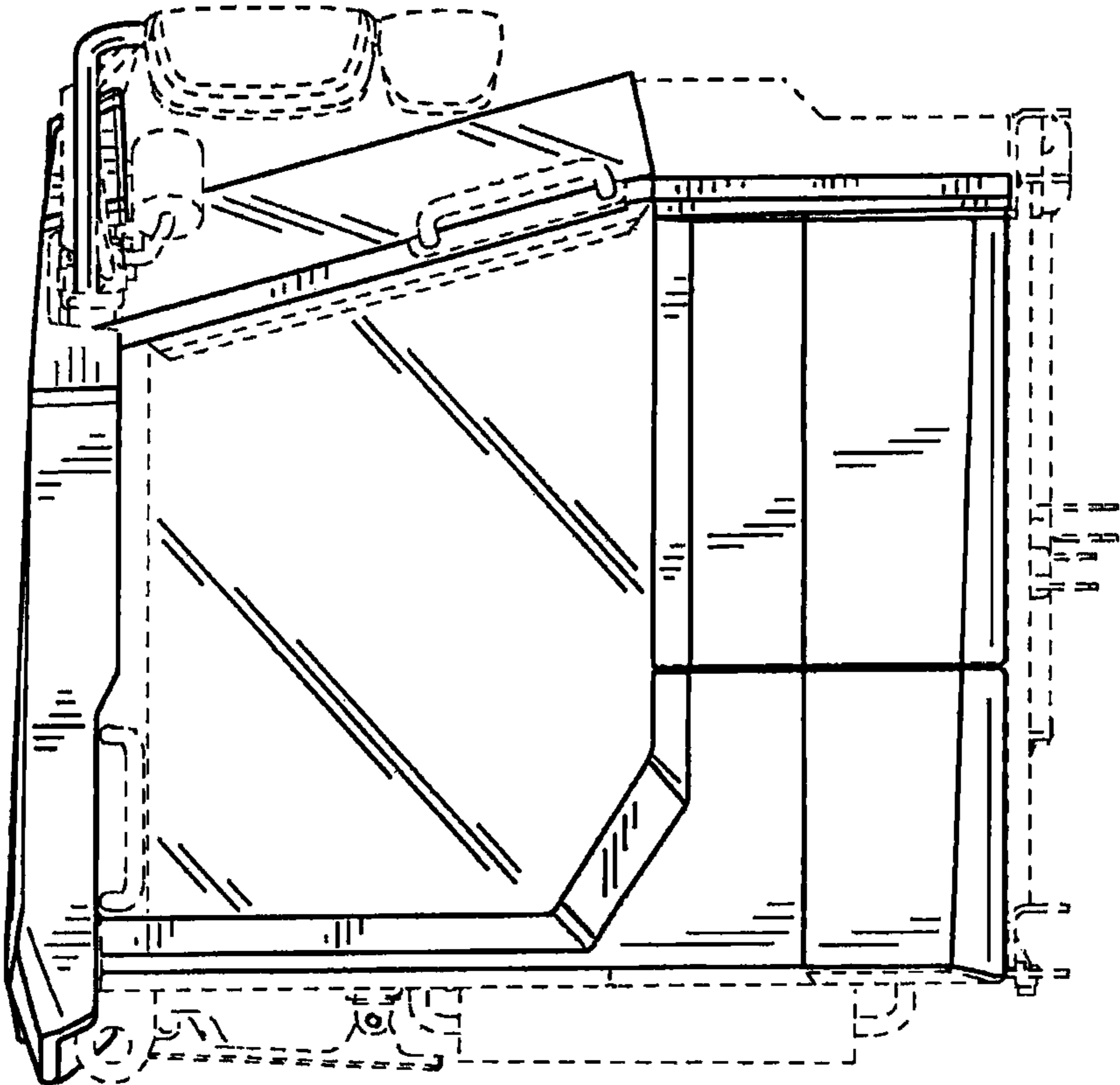

FIG. 5

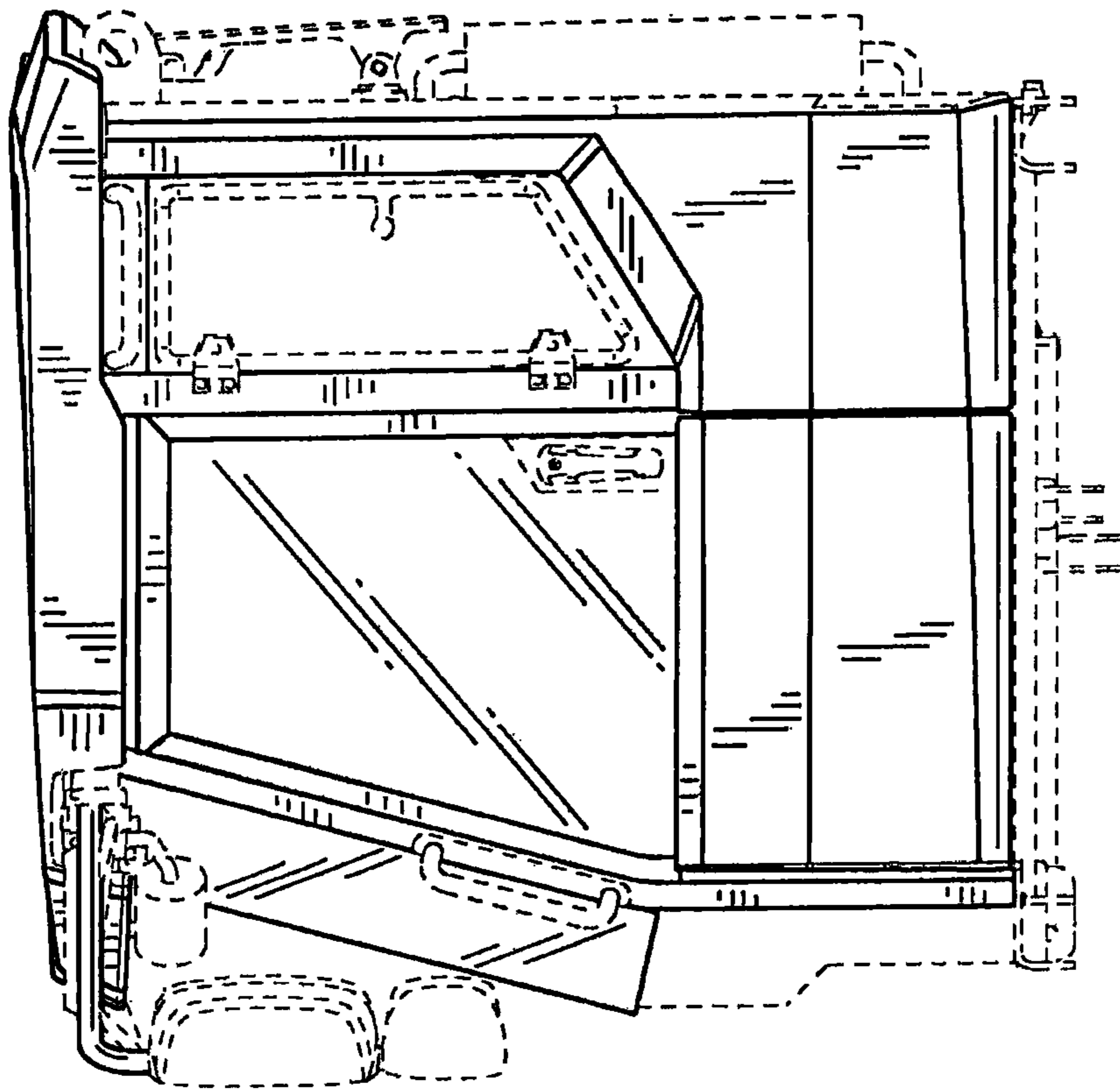

FIG. 6

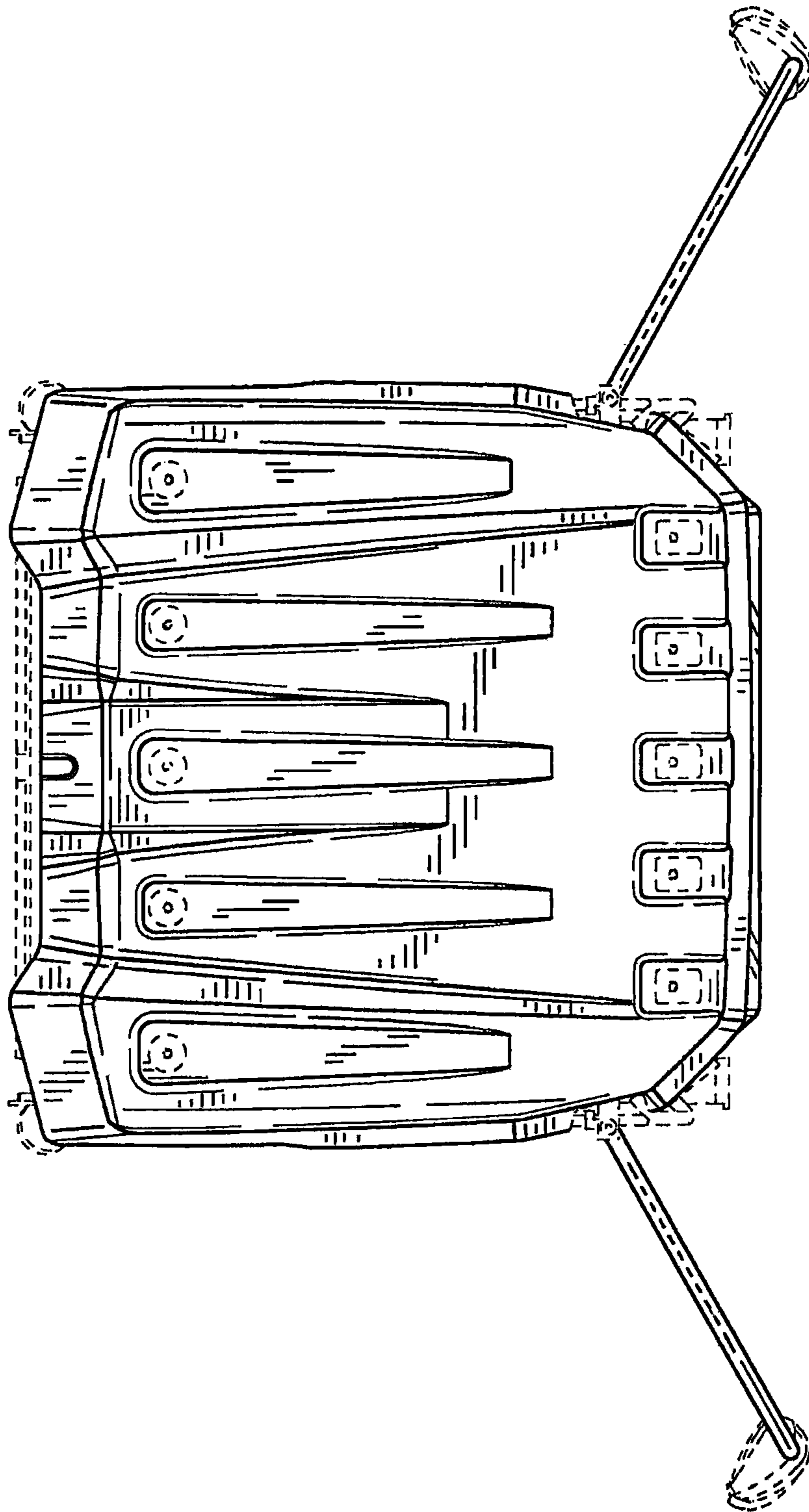

FIG. 7