

US00D734610S

(12) **United States Design Patent**  
**Christie**

(10) **Patent No.:** **US D734,610 S**  
(45) **Date of Patent:** **\*\* Jul. 21, 2015**

- (54) **CADDY**
- (71) Applicant: **William L. Christie**, Olathe, KS (US)
- (72) Inventor: **William L. Christie**, Olathe, KS (US)
- (\*\*) Term: **14 Years**
- (21) Appl. No.: **29/452,817**
- (22) Filed: **Apr. 22, 2013**
- (51) **LOC (10) Cl.** ..... **03-01**
- (52) **U.S. Cl.**  
USPC ..... **D3/304**
- (58) **Field of Classification Search**  
USPC ..... D3/304, 307-314, 315; D9/432, 741;  
D19/75, 77; 206/371-373, 504;  
211/10-11, 13.1, 45, 50, 55, 126.9;  
D6/512, 515, 569  
CPC .... A45C 13/083; A47F 1/04; B65D 71/0003;  
B65D 2543/00222; B65D 2543/00296  
See application file for complete search history.

- D667,633 S \* 9/2012 Searcy ..... D3/313
- D677,055 S \* 3/2013 Nowicky et al. .... D3/304
- D694,975 S \* 12/2013 Lambertson et al. .... D32/53
- D696,657 S \* 12/2013 Cohen ..... D14/251
- D699,045 S \* 2/2014 Gomes et al. .... D6/513
- D720,358 S \* 12/2014 Ginsterblum ..... D14/447

\* cited by examiner

*Primary Examiner* — Kelley Donnelly  
(74) *Attorney, Agent, or Firm* — Law Office of Mark Brown, LLC; Christopher M. DeBacker; Mark Brown

(57) **CLAIM**  
The ornamental design for a caddy, as shown and described.

**DESCRIPTION**

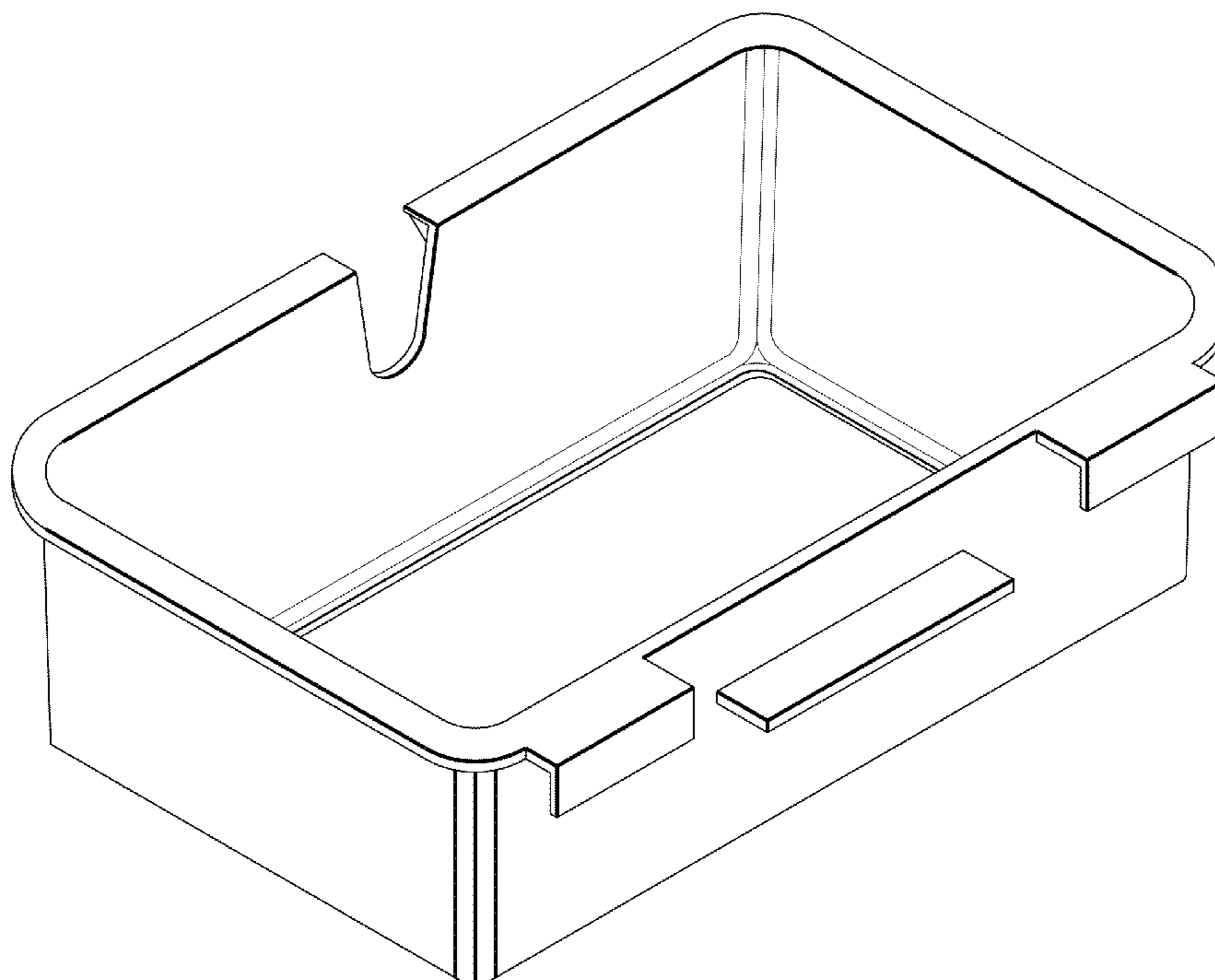
FIG. 1 is an upper rear perspective view of a caddy showing my new design;  
 FIG. 2 is an upper rear perspective view thereof;  
 FIG. 3 is a sectional view thereof taken about the line of FIG. 7;  
 FIG. 4 is a side elevational view thereof; the reverse side being a mirror image thereof;  
 FIG. 5 is a front elevational view thereof;  
 FIG. 6 is rear elevational view thereof;  
 FIG. 7 is a top plan view thereof; and,  
 FIG. 8 is a bottom plan view thereof.  
 The broken lines shown in FIG. 2 indicating a bag as inserted into the bag receiving opening for illustrative purposes only and form no part of the claimed design. The broken lines indicating a gutter for mounting the caddy as shown in FIG. 3 are shown for illustrative purposes only and form no part of the claimed design.

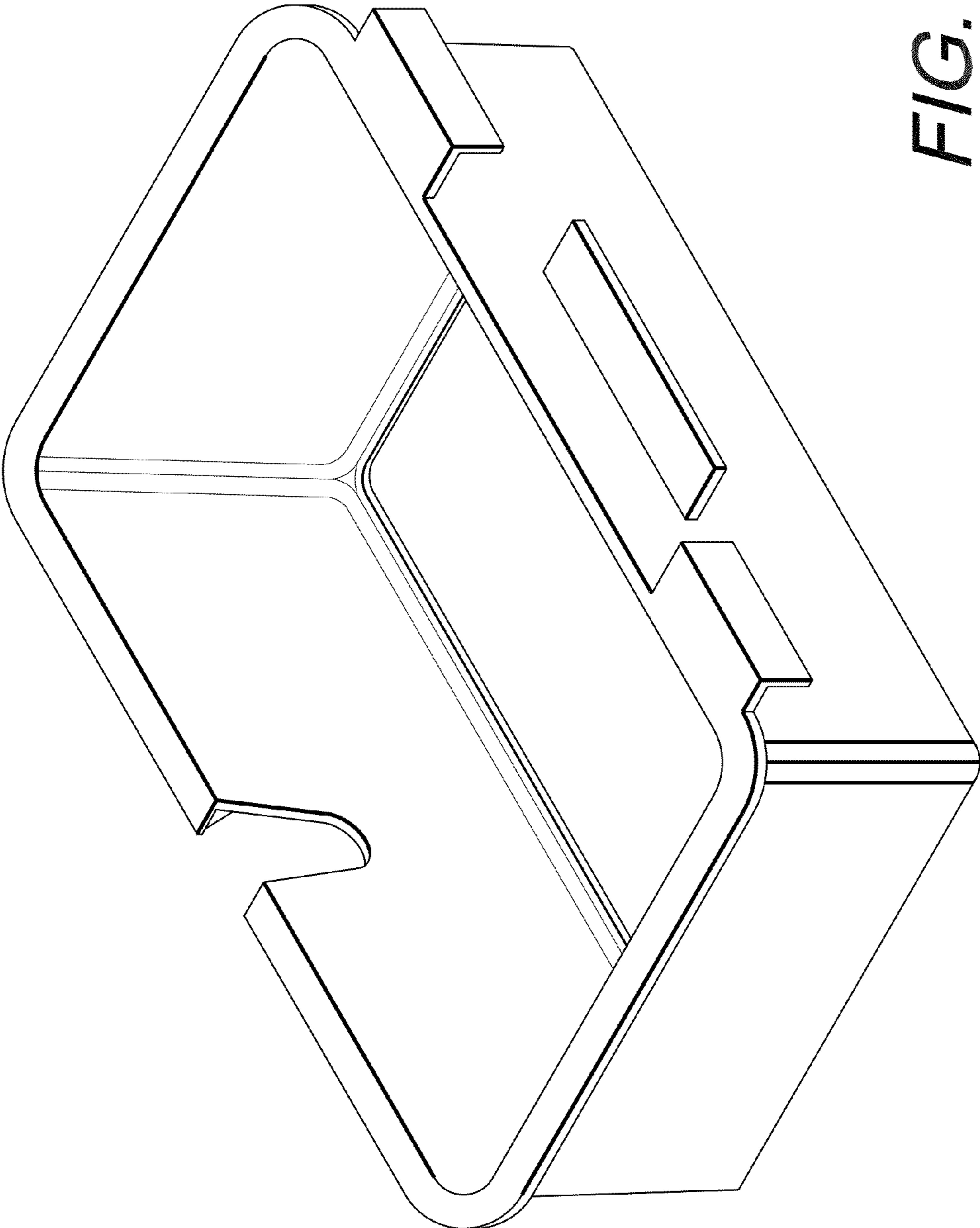
(56) **References Cited**

U.S. PATENT DOCUMENTS

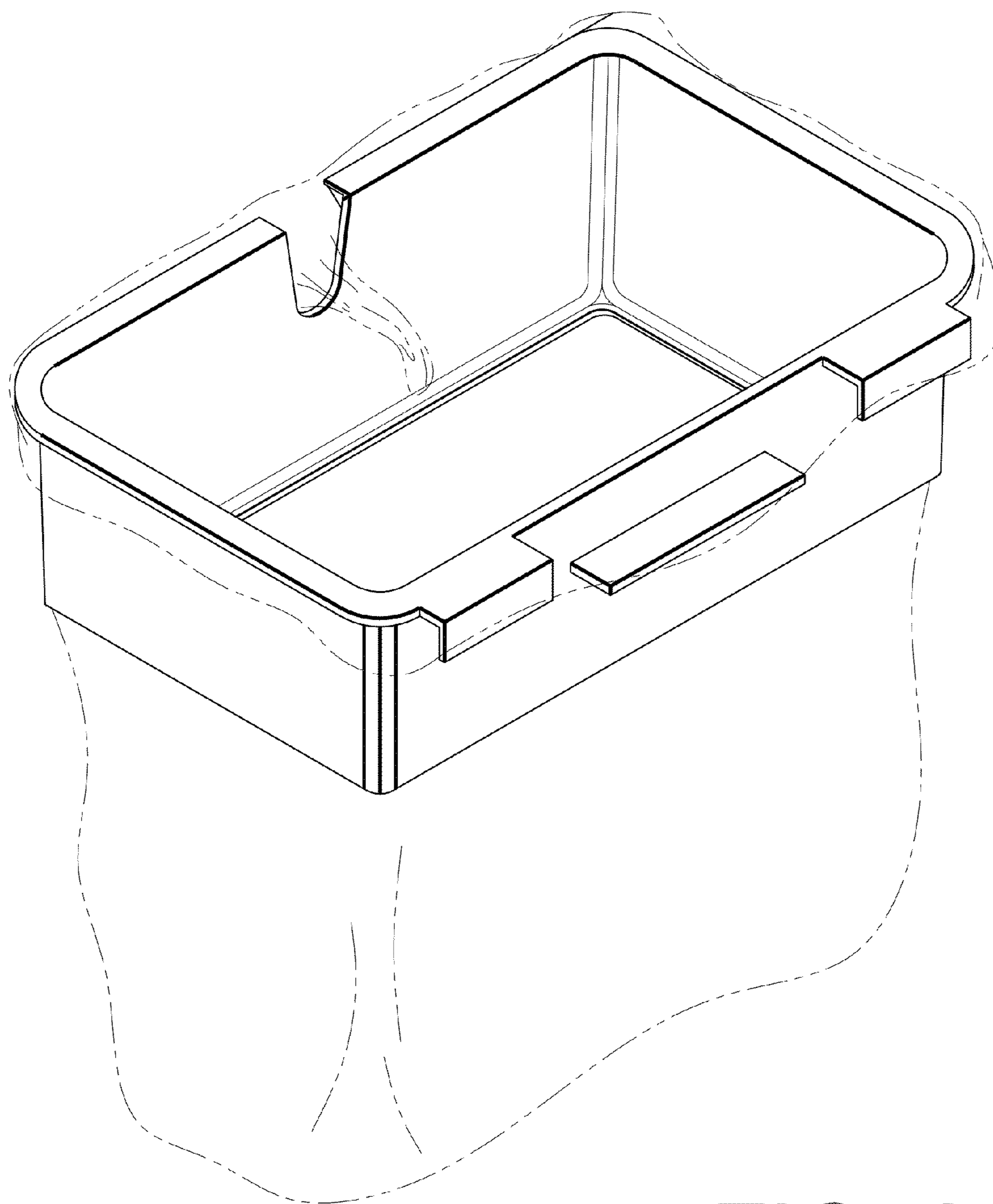
- D309,970 S \* 8/1990 Embree et al. .... D3/304
- D358,370 S \* 5/1995 Guppy ..... D13/184
- D361,664 S \* 8/1995 Brown ..... D3/315
- D378,734 S \* 4/1997 Hardy et al. .... D9/425
- D392,804 S \* 3/1998 Wilkening et al. .... D3/313
- D600,017 S 9/2009 Christie
- 7,891,040 B2 2/2011 Christie
- D634,546 S \* 3/2011 Horwitz ..... D3/320
- D636,198 S \* 4/2011 Gibbs ..... D6/513
- D639,558 S \* 6/2011 Searcy ..... D3/304

**1 Claim, 7 Drawing Sheets**





*FIG. 1*



**FIG. 2**

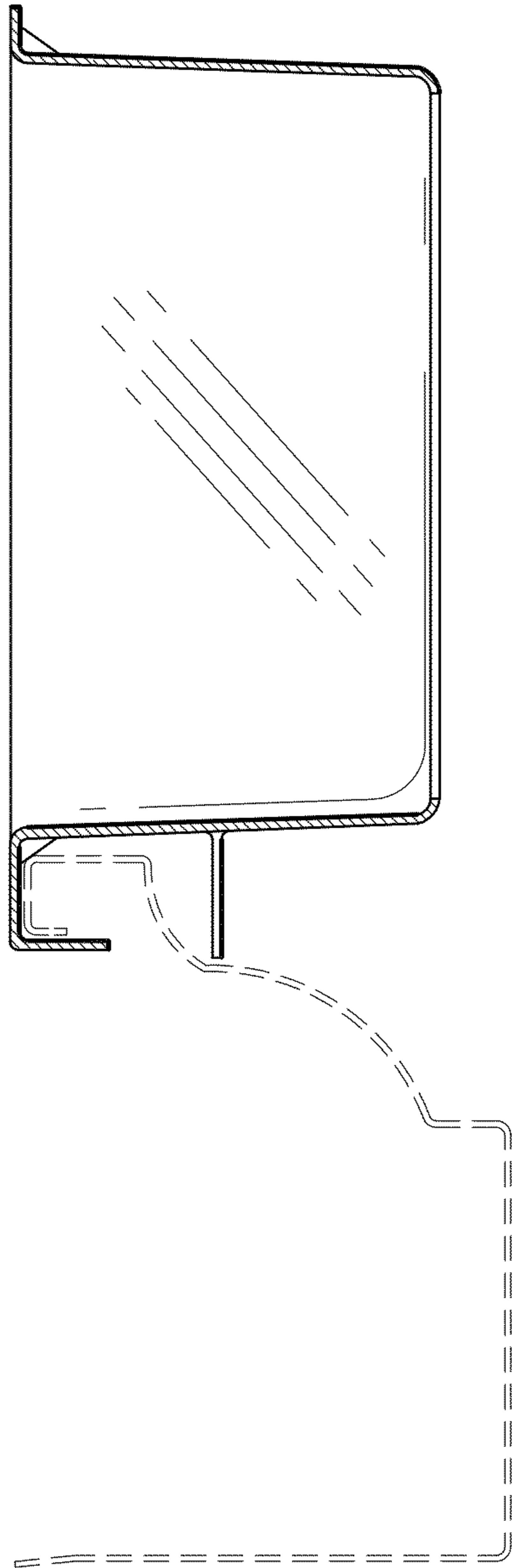
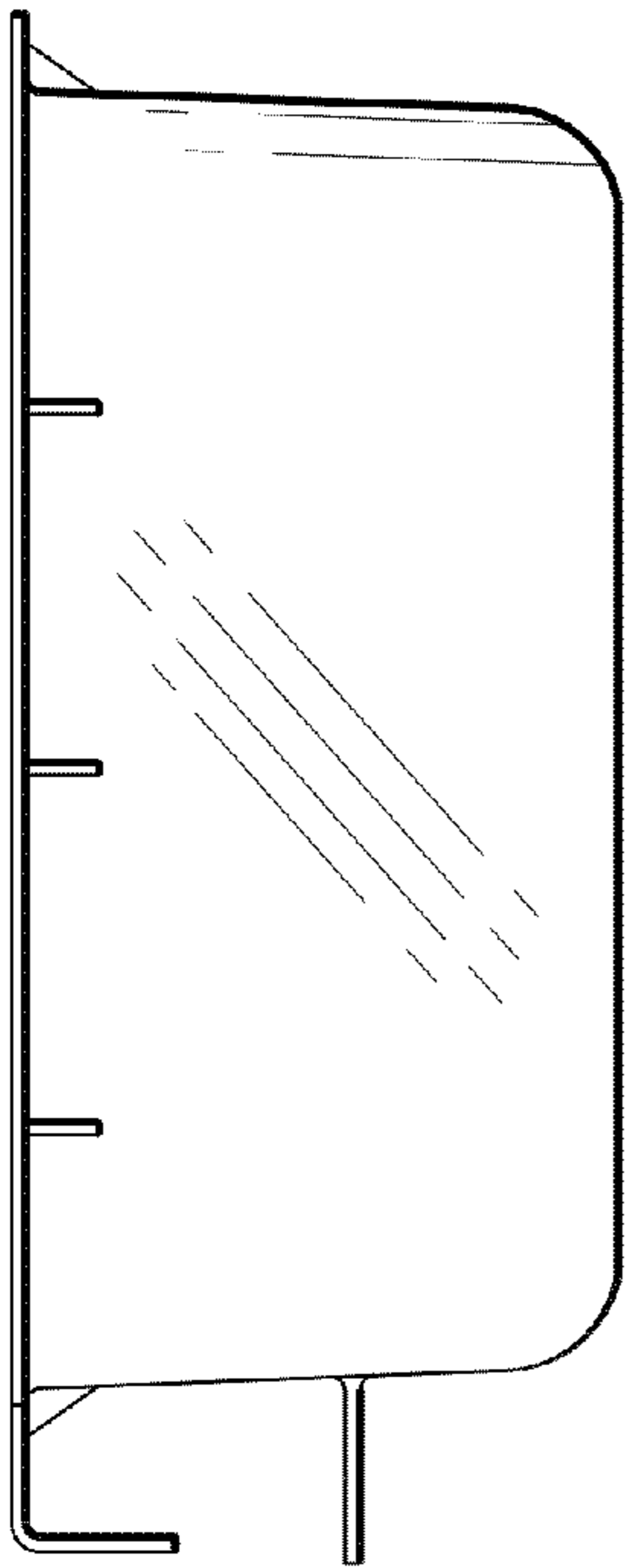
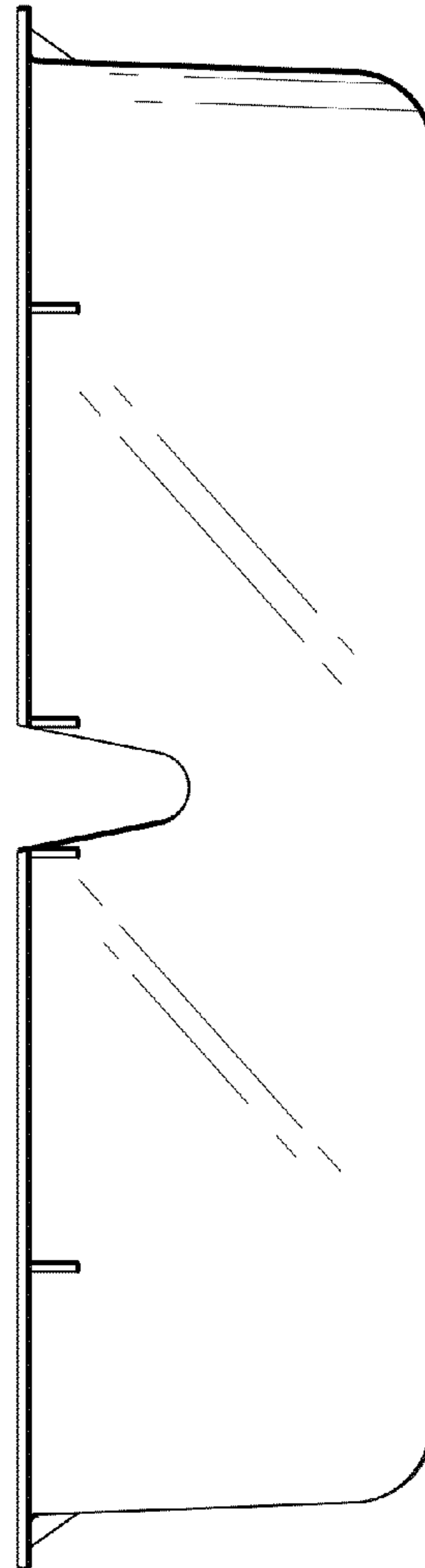


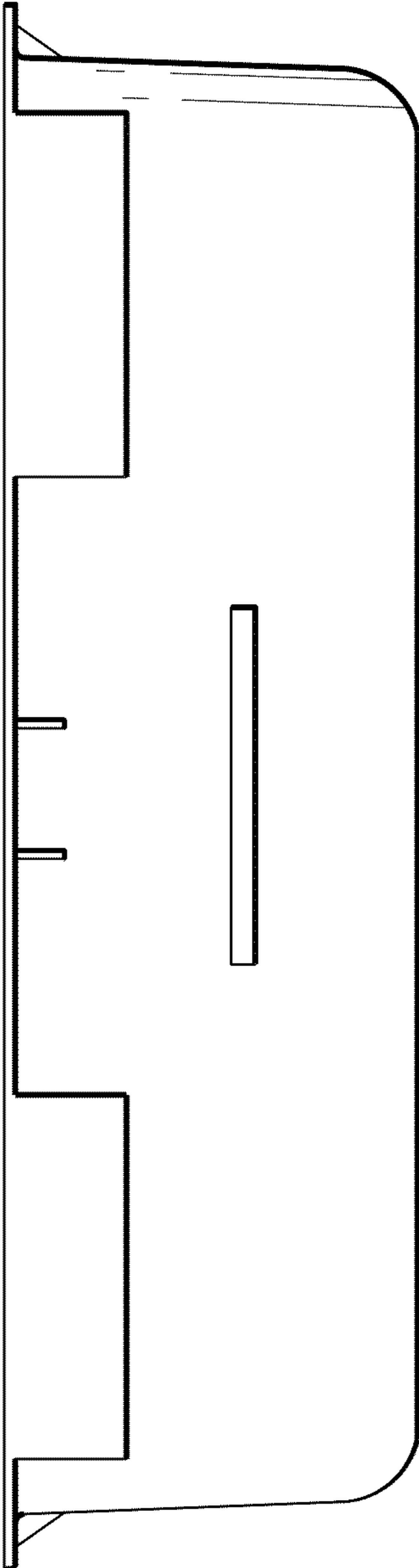
FIG. 3



**FIG. 4**

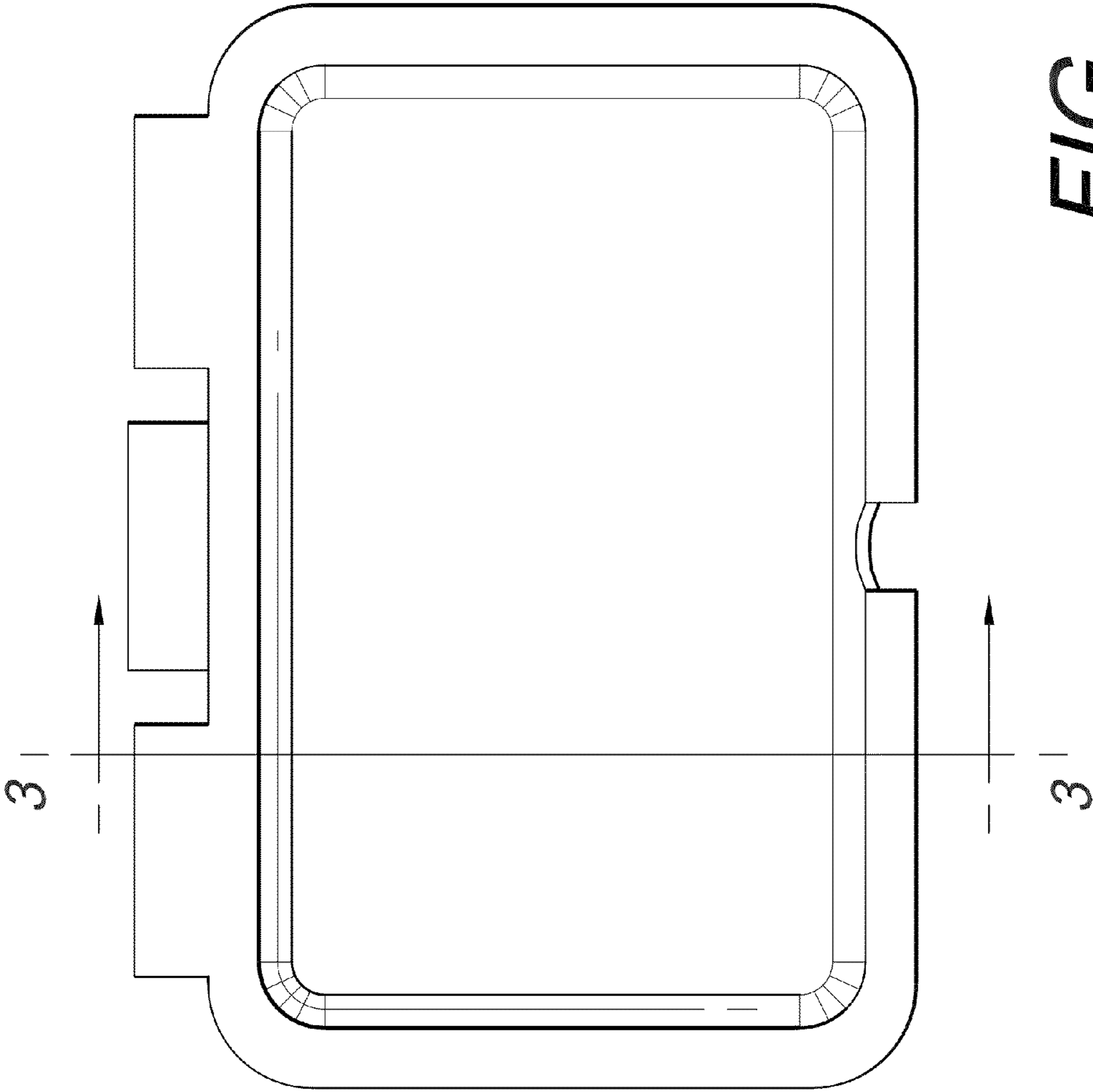


**FIG. 5**

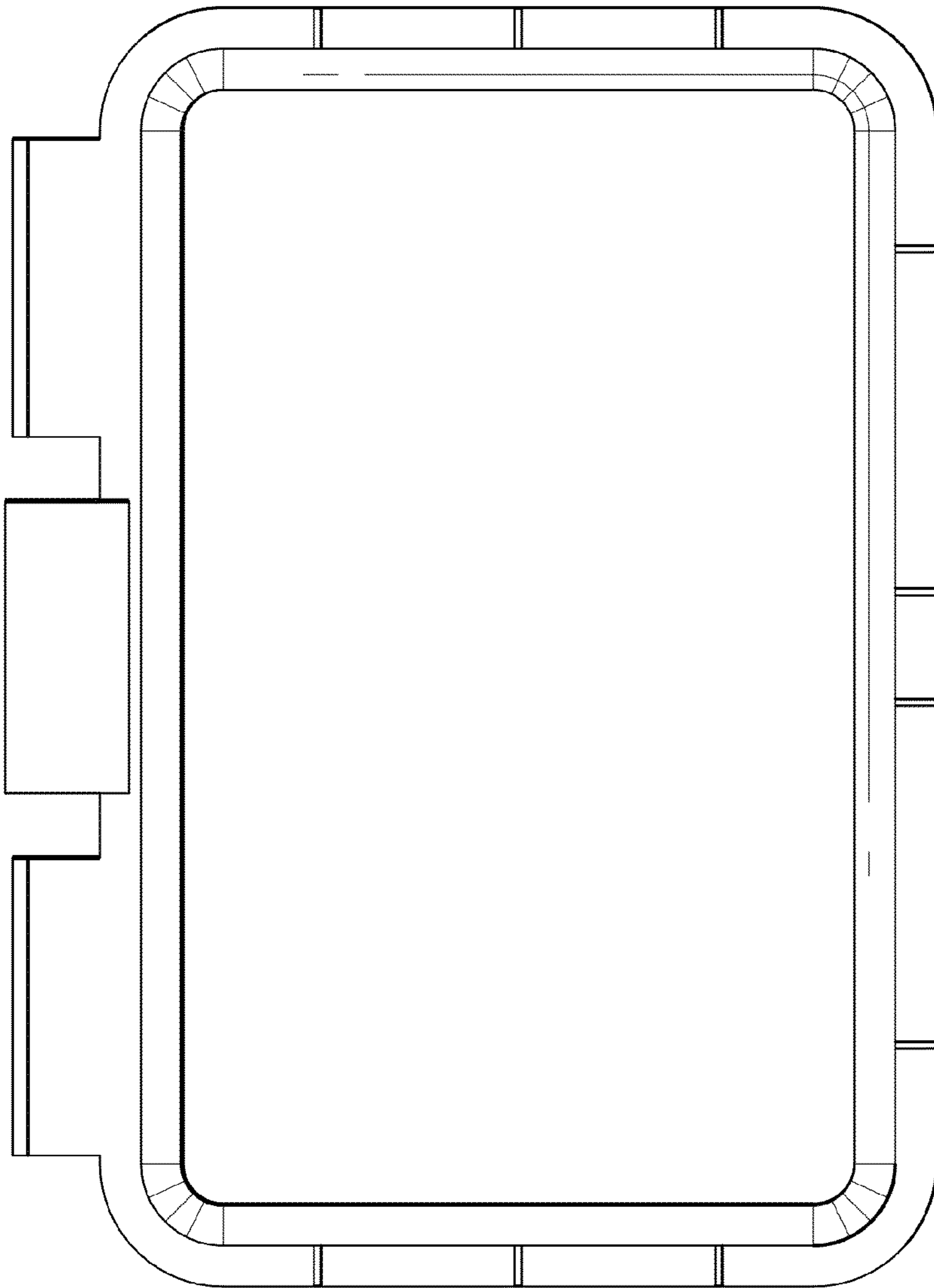


*FIG. 6*





**FIG. 7**



*FIG. 8*