

US00D734589S

(12) **United States Design Patent**
Wu et al.

(10) **Patent No.:** **US D734,589 S**
(45) **Date of Patent:** **** Jul. 14, 2015**

(54) **PERSONNEL LIFT VEHICLE**

(56) **References Cited**

(71) Applicant: **BIG LIFT, LLC**, Lombard, IL (US)

U.S. PATENT DOCUMENTS

(72) Inventors: **Lili Wu**, Hangzhou (CN); **Nengwen Bao**, Hangzhou (CN); **Linjie Xu**, Hangzhou (CN); **Qichen Ma**, Hangzhou (CN); **Jin Hui He**, Hangzhou (CN)

D222,694	S	*	12/1971	Goodacre	D34/34
D358,925	S	*	5/1995	Chung et al.	D34/34
D379,020	S	*	4/1997	Avitan	D34/34
D407,176	S	*	3/1999	Henshaw et al.	D34/34
D407,177	S	*	3/1999	Henshaw et al.	D34/34
D544,174	S	*	6/2007	Quinlan et al.	D34/34
D585,623	S	*	1/2009	Quinlan et al.	D34/34
D640,855	S	*	6/2011	Ruppert et al.	D34/34
D684,333	S	*	6/2013	Knies	D34/34

(73) Assignee: **BIG LIFT, LLC**, Lombard, IL (US)

* cited by examiner

(**) Term: **14 Years**

Primary Examiner — Cynthia Ramirez

(21) Appl. No.: **29/520,404**

(74) *Attorney, Agent, or Firm* — Cook Alex Ltd.

(22) Filed: **Mar. 13, 2015**

(57) **CLAIM**

We claim the ornamental design for a personnel lift vehicle, as shown and described.

Related U.S. Application Data

DESCRIPTION

(62) Division of application No. 29/473,815, filed on Nov. 26, 2013, now Pat. No. Des. 730,614.

(51) **LOC (10) Cl.** **12-05**

(52) **U.S. Cl.**
USPC **D34/34**

(58) **Field of Classification Search**
USPC D34/34; 187/222, 234, 226, 238;
414/631, 575, 592; 180/89.12, 89.13,
180/89.17

CPC B66F 16/003; B66F 9/24; B66F 9/0755;
B66F 9/12; B66F 9/20; B66F 9/22; B66F
9/08; B66F 9/07563; B66F 9/075; B66F
9/082; B66F 9/122; B66F 9/146

See application file for complete search history.

FIG. 1 is a front perspective view of a personnel lift vehicle according to our new design;
FIG. 2 is a rear perspective view of the embodiment in FIG. 1;
FIG. 3 is a rear elevational view of the embodiment in FIG. 1;
FIG. 4 is a right side elevational view of the embodiment in FIG. 1;
FIG. 5 is a left side elevational view of the embodiment in FIG. 1;
FIG. 6 is a front elevational view of the embodiment in FIG. 1;
FIG. 7 is a top plan view of the embodiment in FIG. 1; and
FIG. 8 is a bottom plan view of the embodiment in FIG. 1.
The broken lines shown in the figures are included for the purpose of illustrating portions of the personnel lift vehicle and form no part of the claimed design.

1 Claim, 7 Drawing Sheets

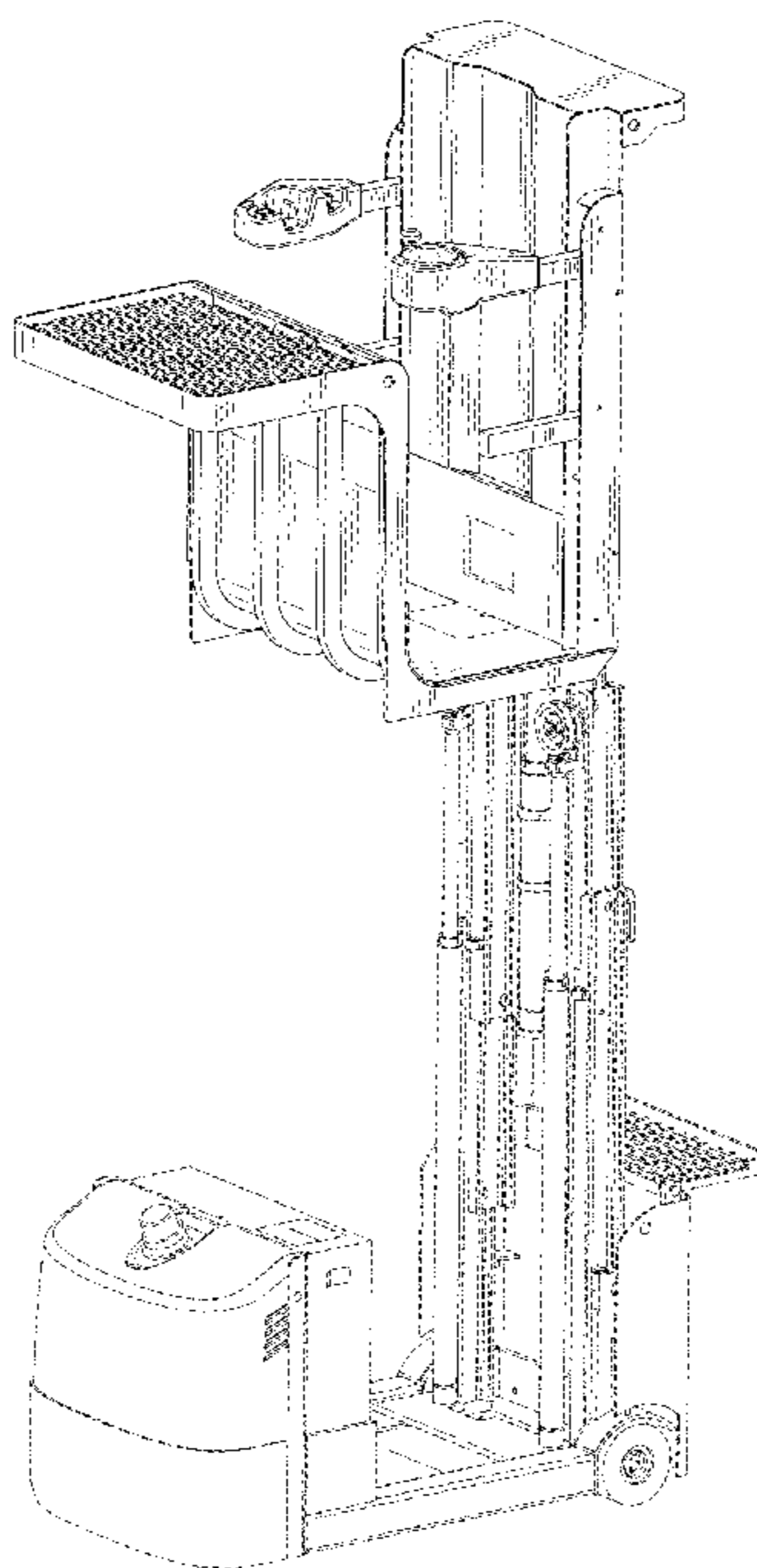

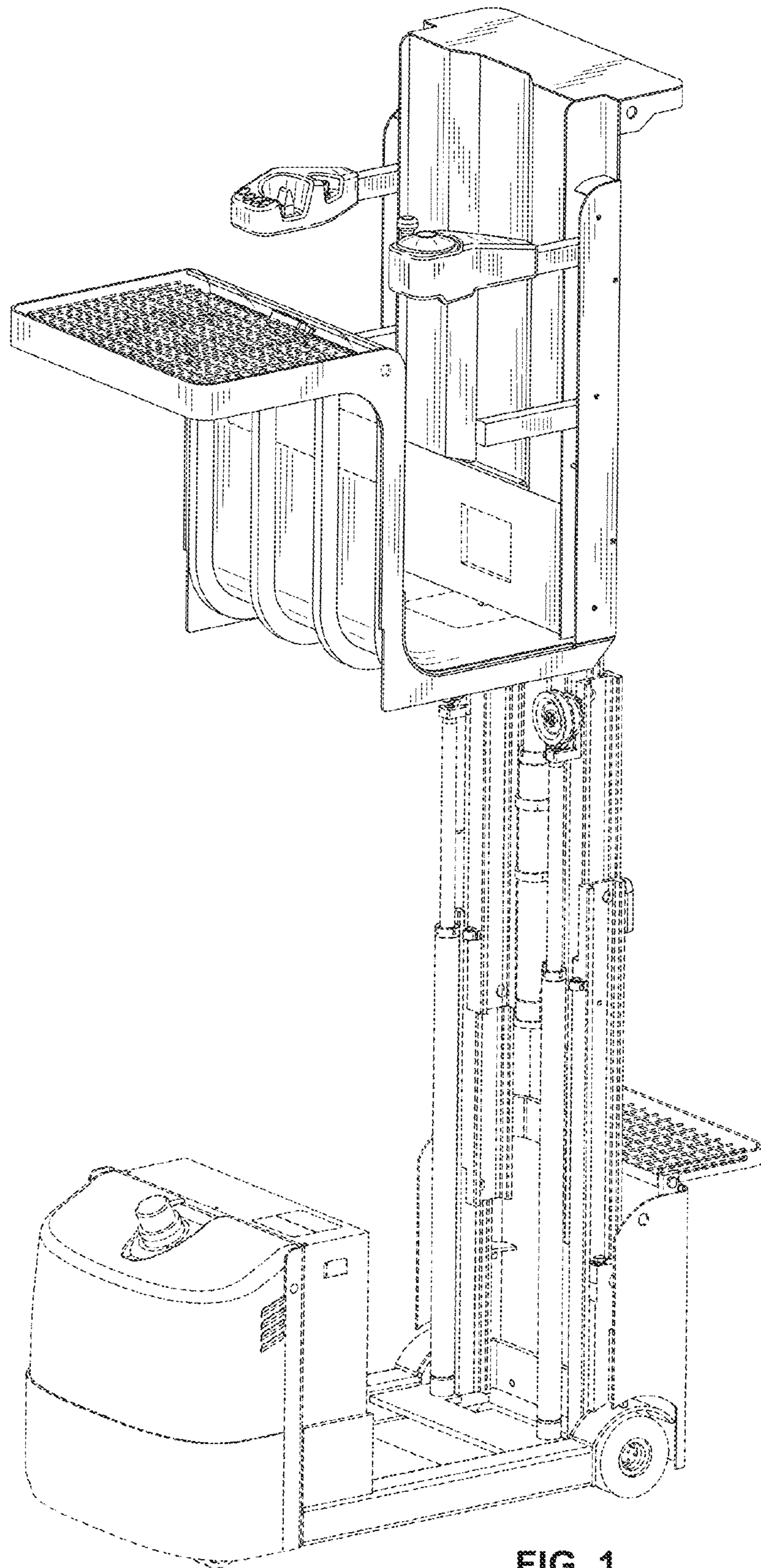

FIG. 1

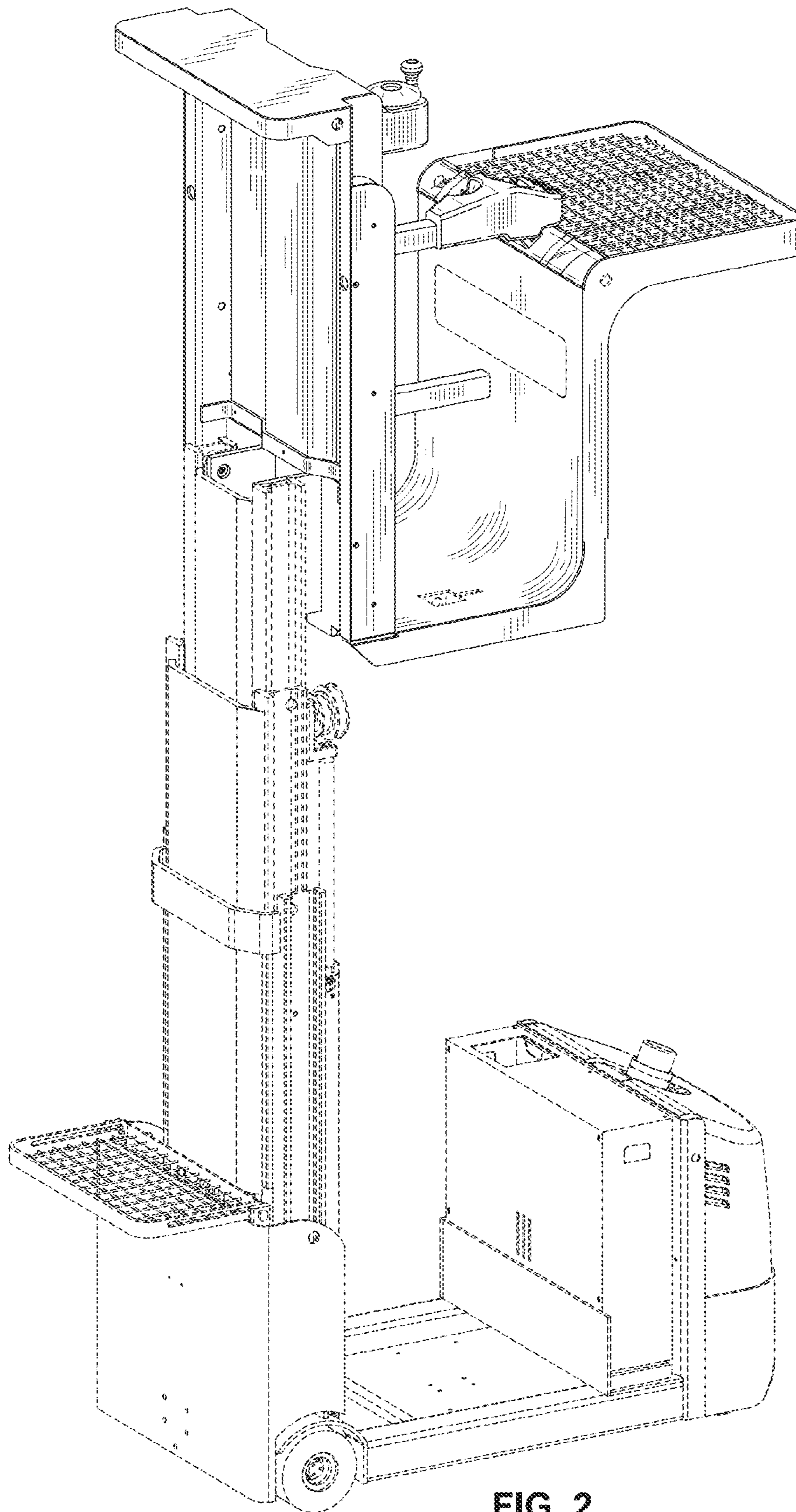

FIG. 2

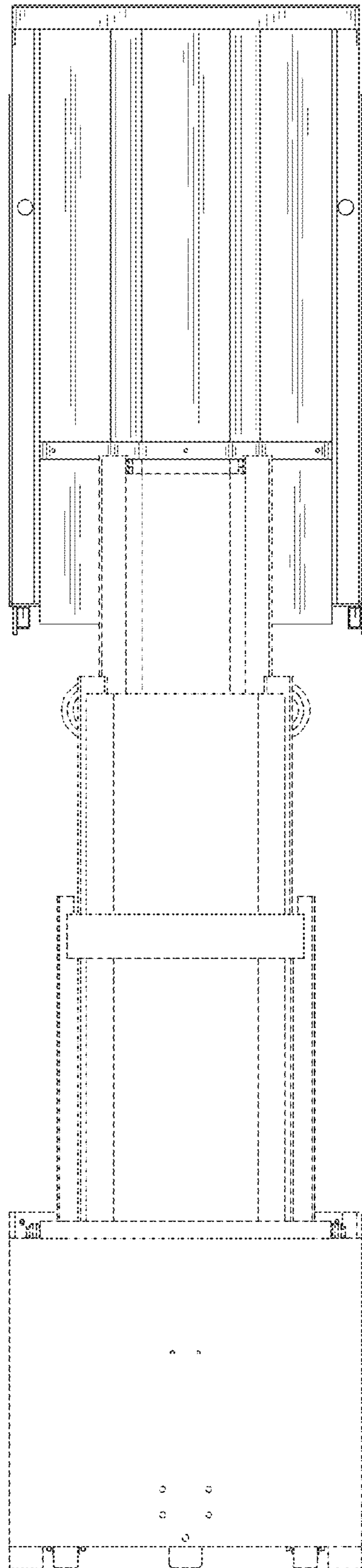

FIG. 3

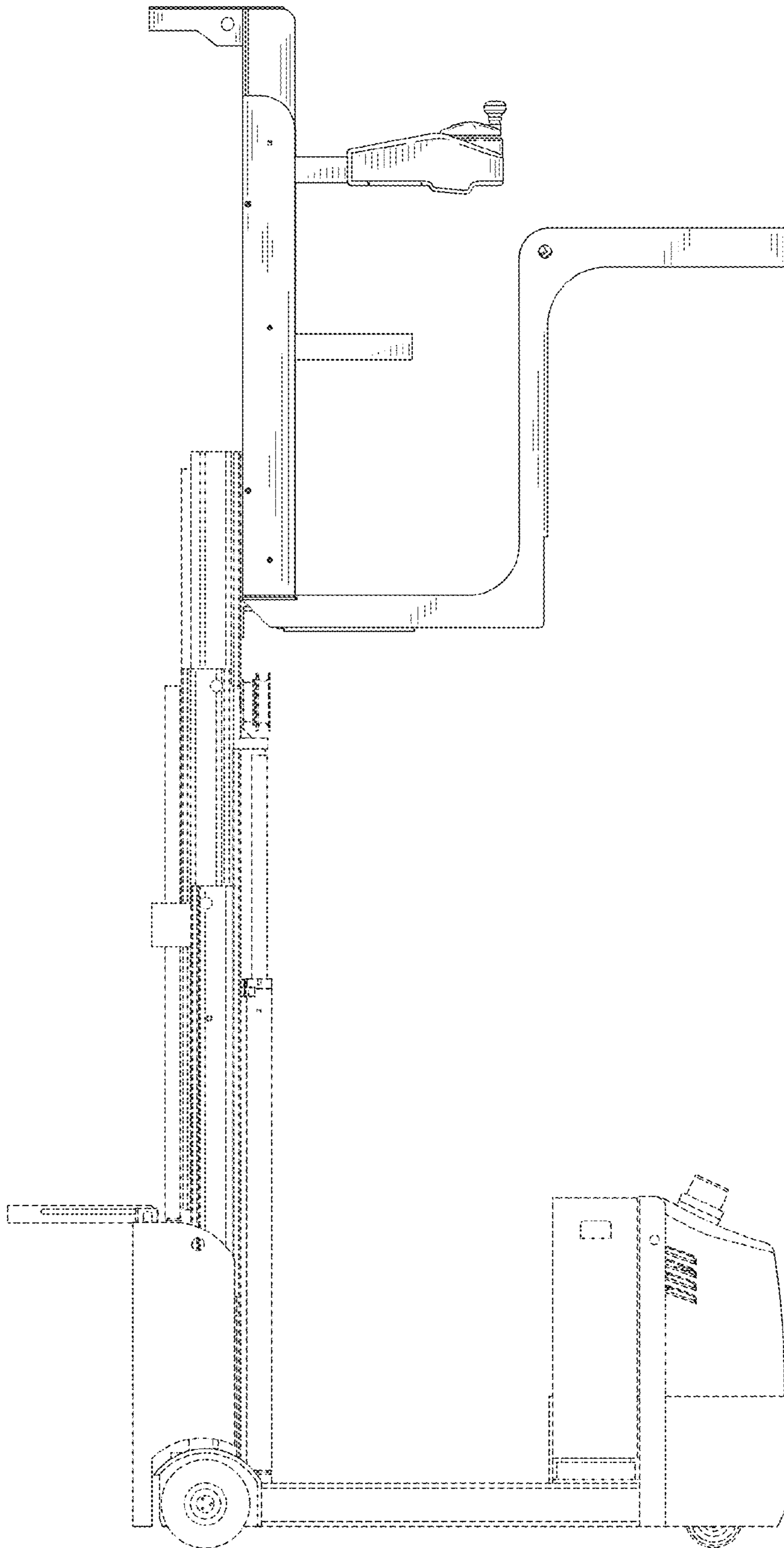

FIG. 4

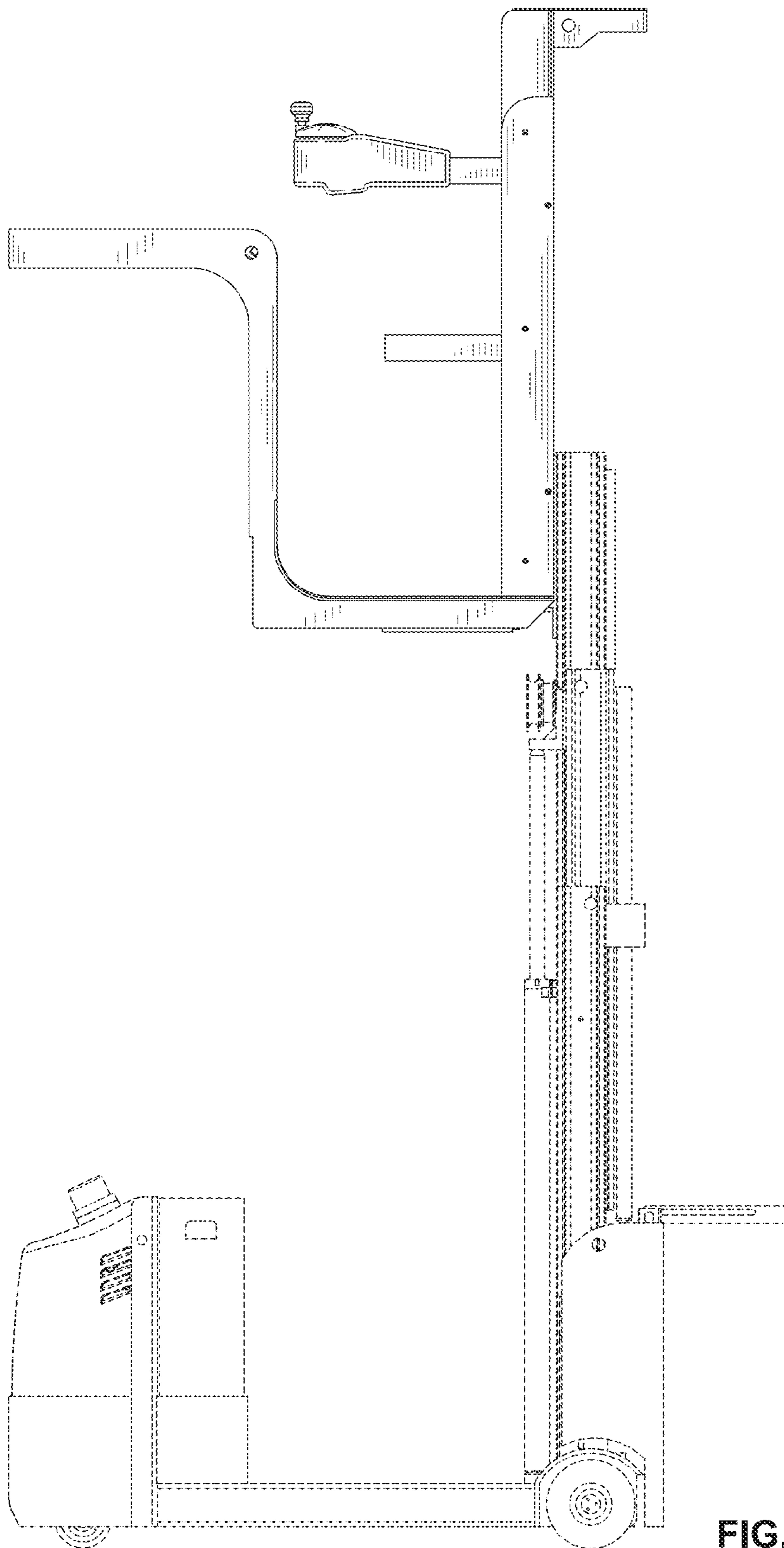

FIG. 5

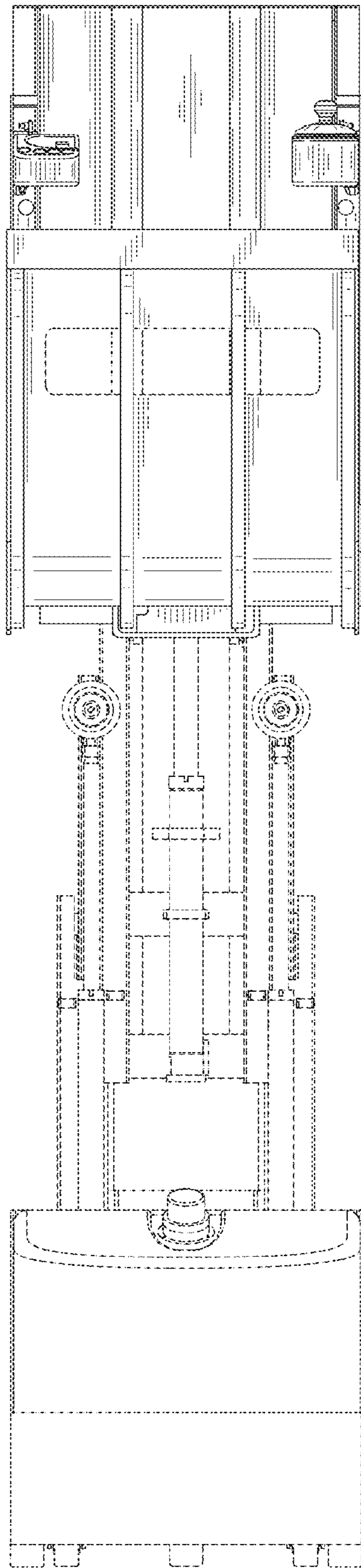

FIG. 6

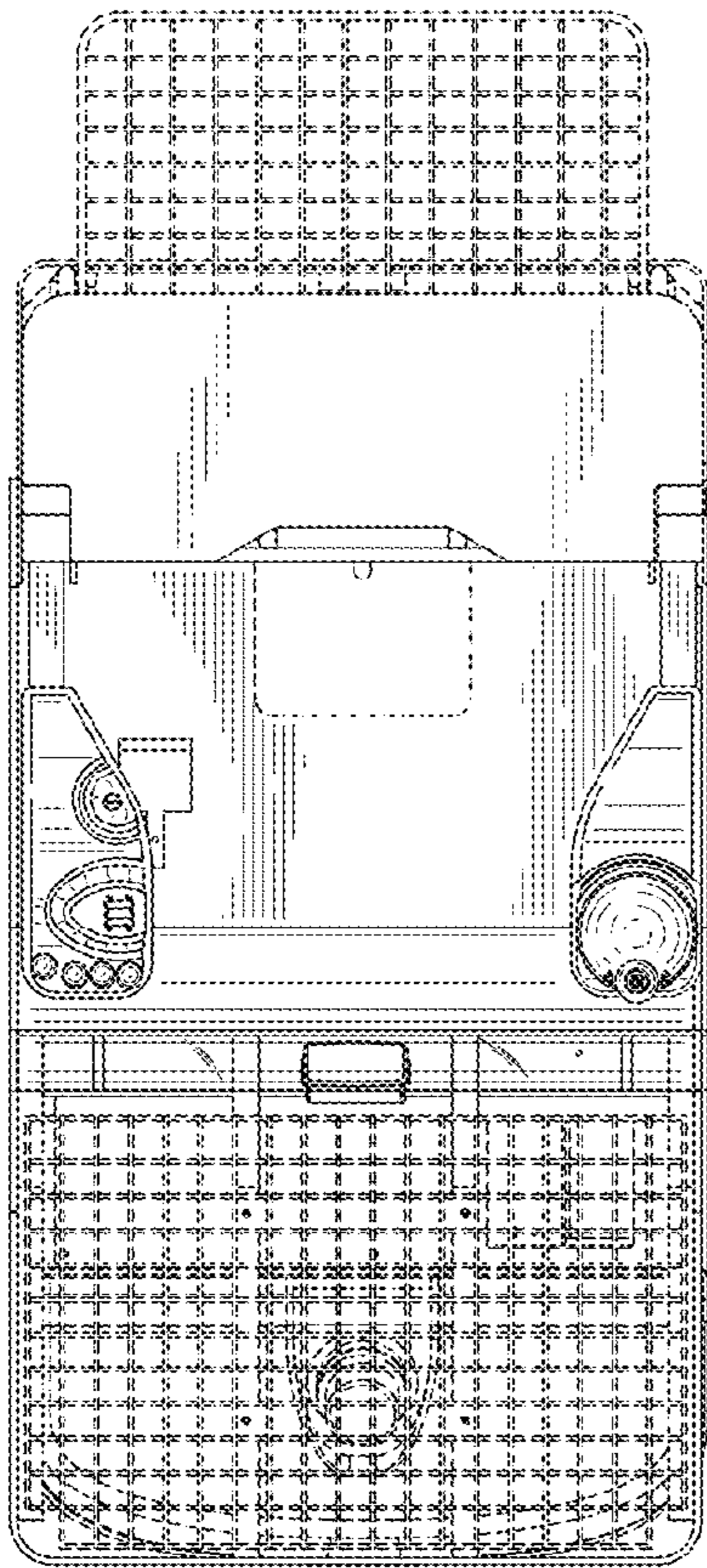

FIG. 7

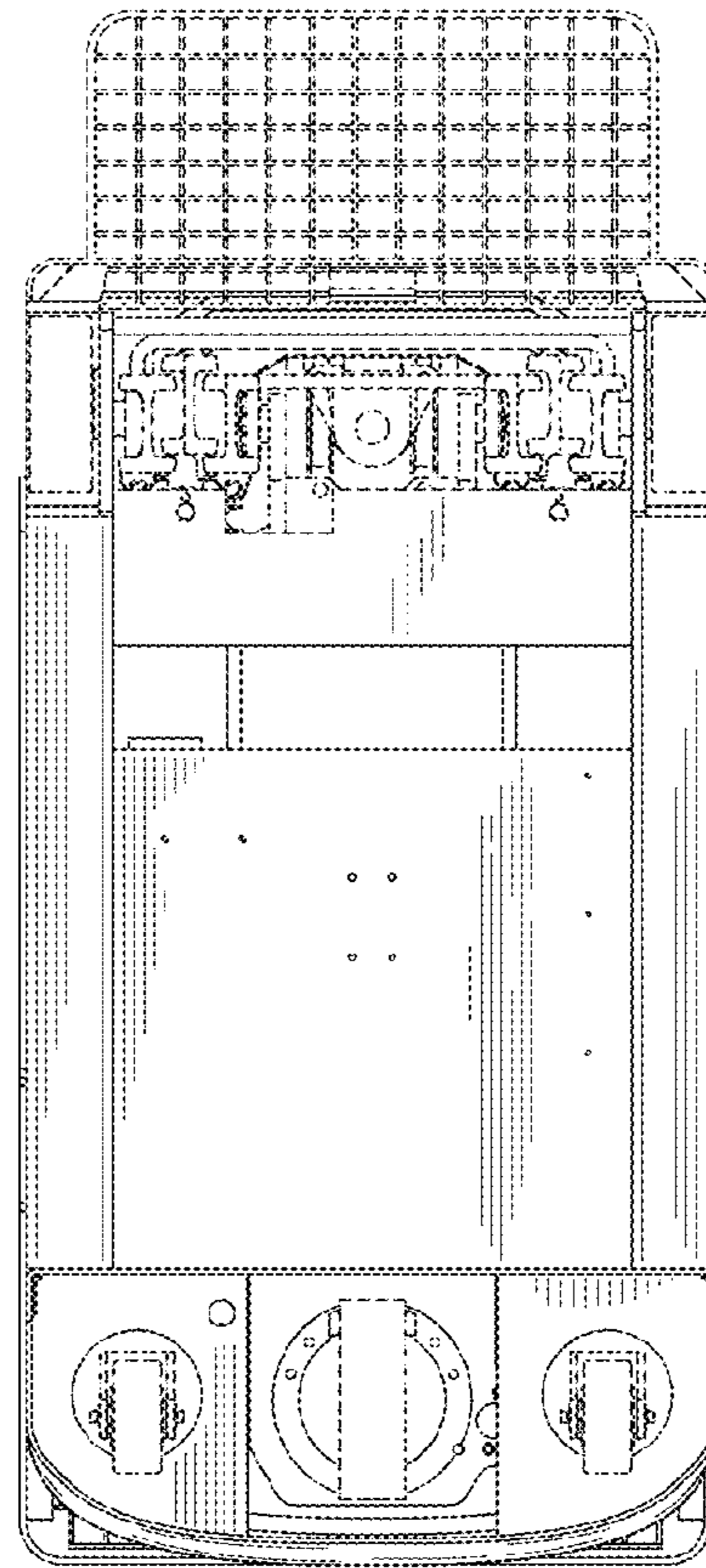

FIG. 8