



US00D733817S

(12) **United States Design Patent**  
**Jorgensen et al.**

(10) **Patent No.:** **US D733,817 S**  
(45) **Date of Patent:** **\*\* Jul. 7, 2015**

(54) **PUTTER TYPE GOLF CLUB**

(71) Applicants: **Douglas C. Jorgensen**, Carlsbad, CA  
(US); **Terrill R. McCabe, Jr.**, Naples,  
FL (US)

(72) Inventors: **Douglas C. Jorgensen**, Carlsbad, CA  
(US); **Terrill R. McCabe, Jr.**, Naples,  
FL (US)

(\*\*) Term: **14 Years**

(21) Appl. No.: **29/499,643**

(22) Filed: **Aug. 18, 2014**

(51) **LOC (10) Cl.** ..... **21-02**

(52) **U.S. Cl.**  
USPC ..... **D21/736**

(58) **Field of Classification Search**  
USPC ..... D21/736-746  
CPC ... A63B 53/065; A63B 53/0487; A63B 53/00  
See application file for complete search history.

(56) **References Cited**

**U.S. PATENT DOCUMENTS**

D207,227 S *	3/1967	Solheim	.....	D21/739
D207,228 S	3/1967	Solheim		
D315,005 S *	2/1991	Solheim	.....	D21/743
D329,890 S *	9/1992	Pinder	.....	D21/742
D346,002 S *	4/1994	Collins	.....	D21/744
D356,615 S *	3/1995	Solheim	.....	D21/743
D357,291 S *	4/1995	Solheim	.....	D21/742
D367,905 S *	3/1996	Kanazawa	.....	D21/742

D373,162 S *	8/1996	Meyer et al.	.....	D21/743
D389,207 S *	1/1998	Cameron	.....	D21/742
D410,267 S *	5/1999	Solheim et al.	.....	D21/736
D428,086 S *	7/2000	Solheim	.....	D21/743
D449,085 S *	10/2001	Breier et al.	.....	D21/744
D512,116 S	11/2005	Miraflor et al.		
D521,580 S *	5/2006	Burrows	.....	D21/736
D548,294 S *	8/2007	Nguyen et al.	.....	D21/736
D552,196 S *	10/2007	Hueber	.....	D21/742
D576,698 S	9/2008	Cameron		
D590,462 S *	4/2009	Hettinger et al.	.....	D21/743
D643,893 S *	8/2011	Rollinson	.....	D21/742
D661,754 S	6/2012	Cameron et al.		
D691,225 S *	10/2013	Hilton et al.	.....	D21/736

\* cited by examiner

*Primary Examiner* — Mitchell Siegel

(57) **CLAIM**

The ornamental design for a putter type golf club, as shown and described.

**DESCRIPTION**

FIG. 1 is a perspective view of a first embodiment of a putter type golf club according to the present design;  
FIG. 2 is a bottom view thereof;  
FIG. 3 is a front elevational view thereof;  
FIG. 4 is a rear elevational view thereof;  
FIG. 5 is a top view thereof;  
FIG. 6 is a toe side elevational view thereof; and,  
FIG. 7 is a heel side elevational view thereof.  
The dashed lines in all figures are shown for illustrative purposes only and form no part of the design.

**1 Claim, 3 Drawing Sheets**

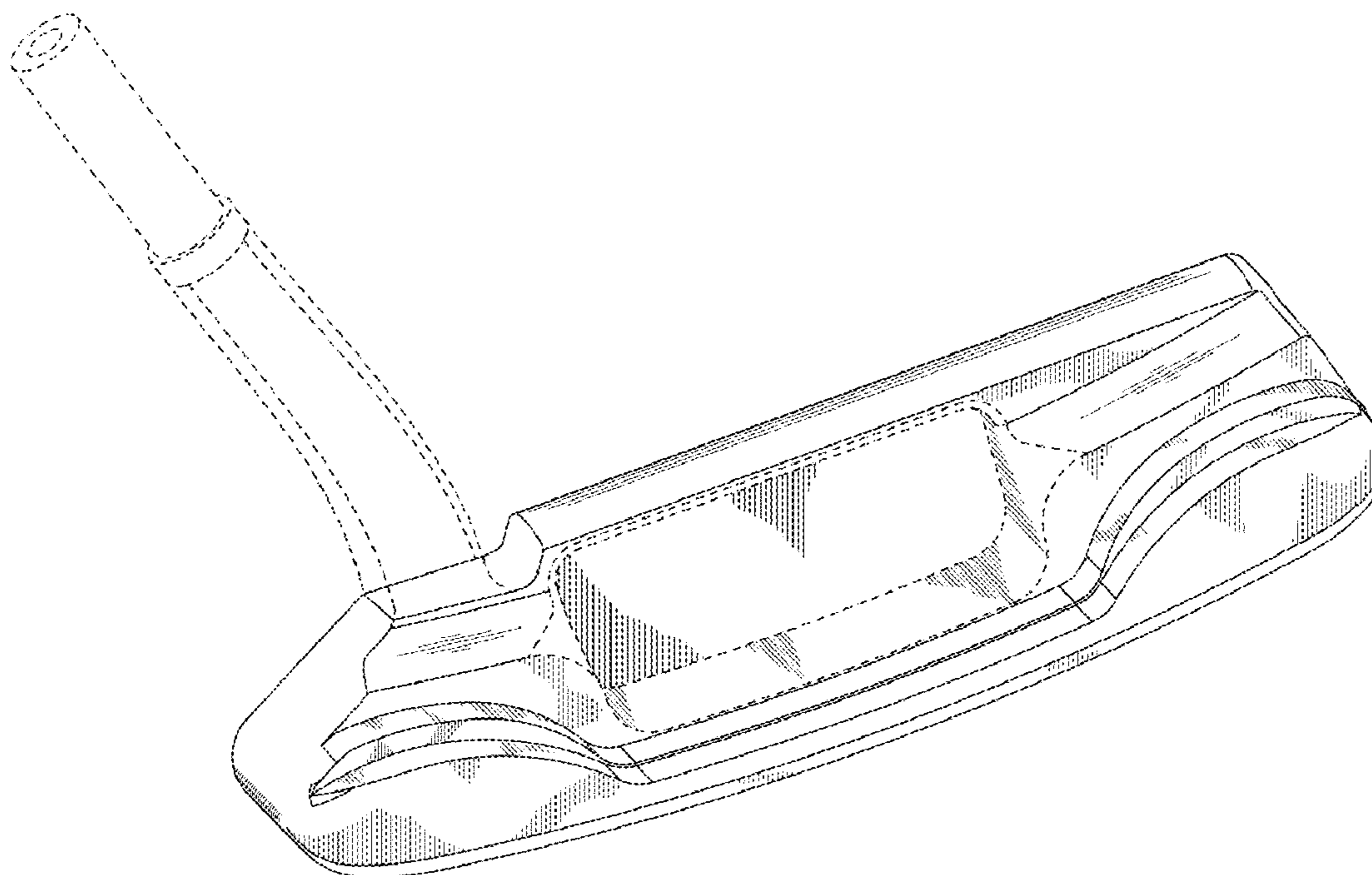

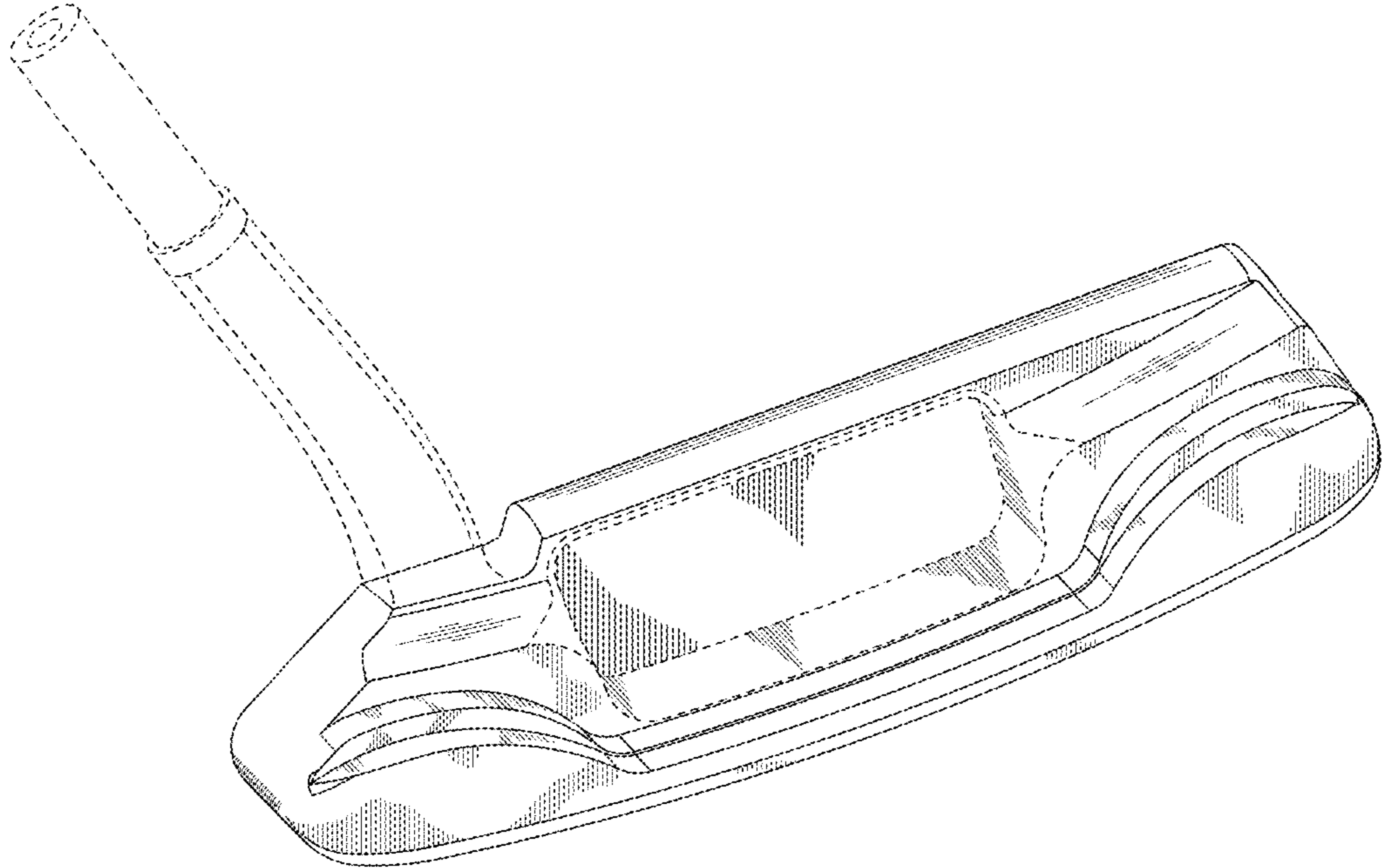

FIG. 1

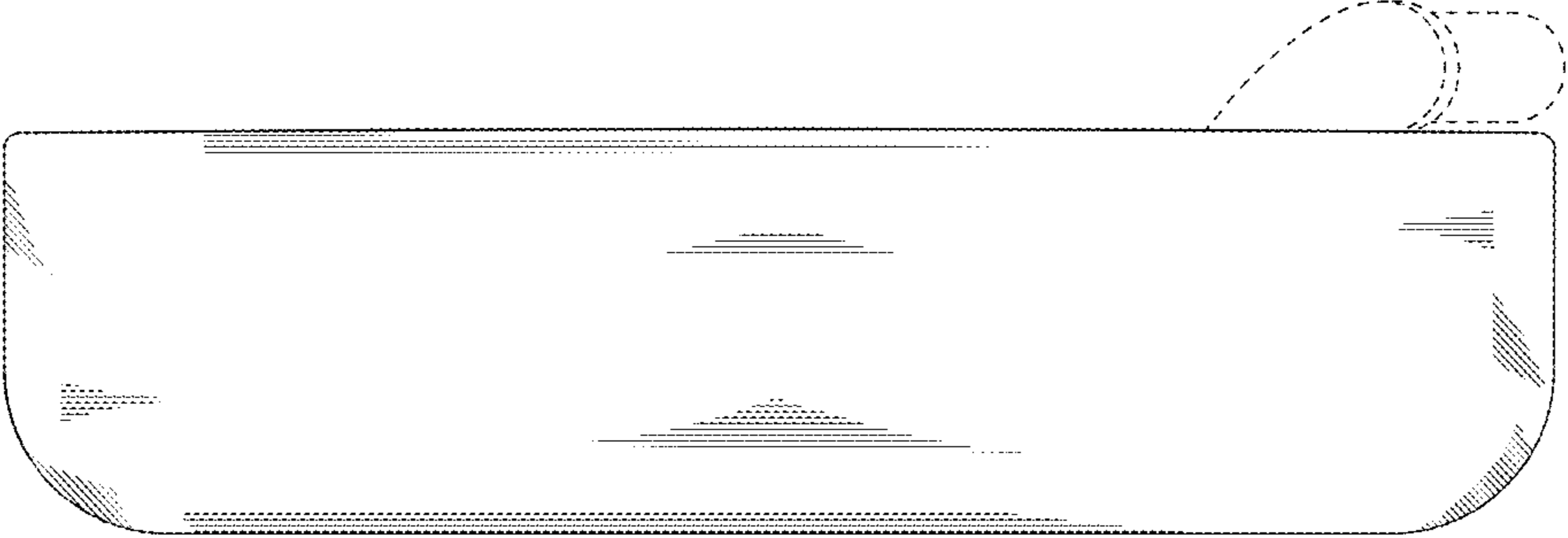

FIG. 2

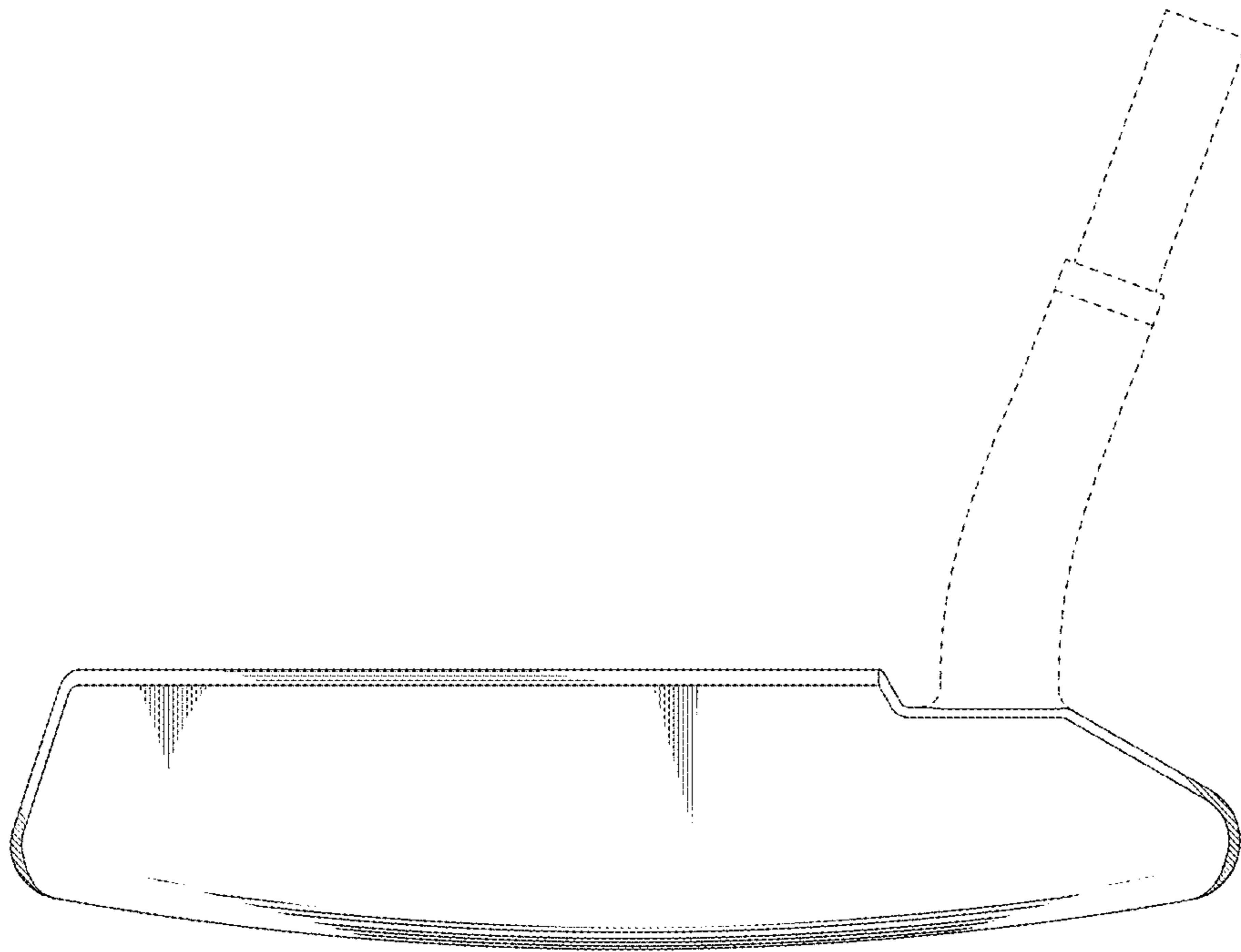

FIG. 3

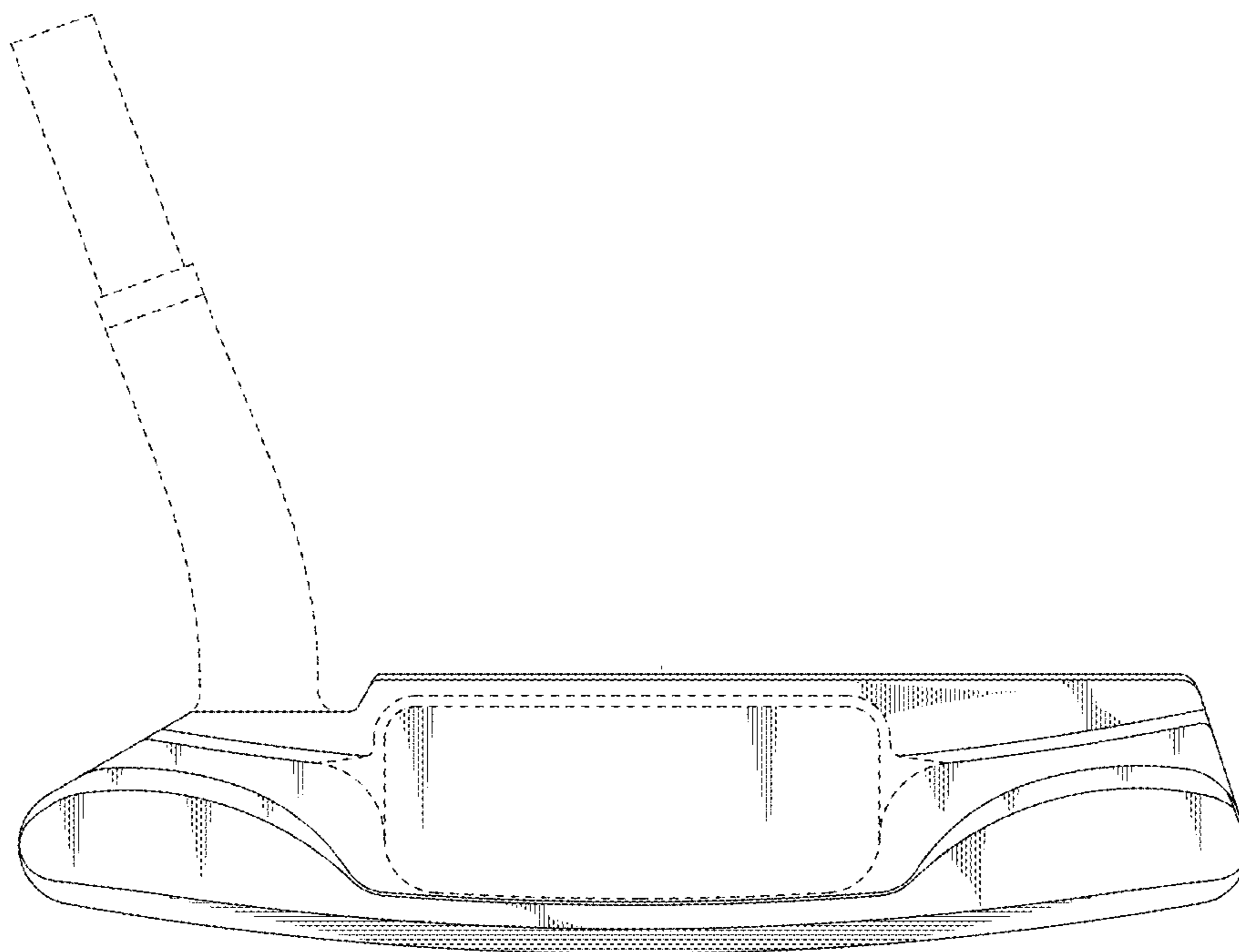

FIG. 4

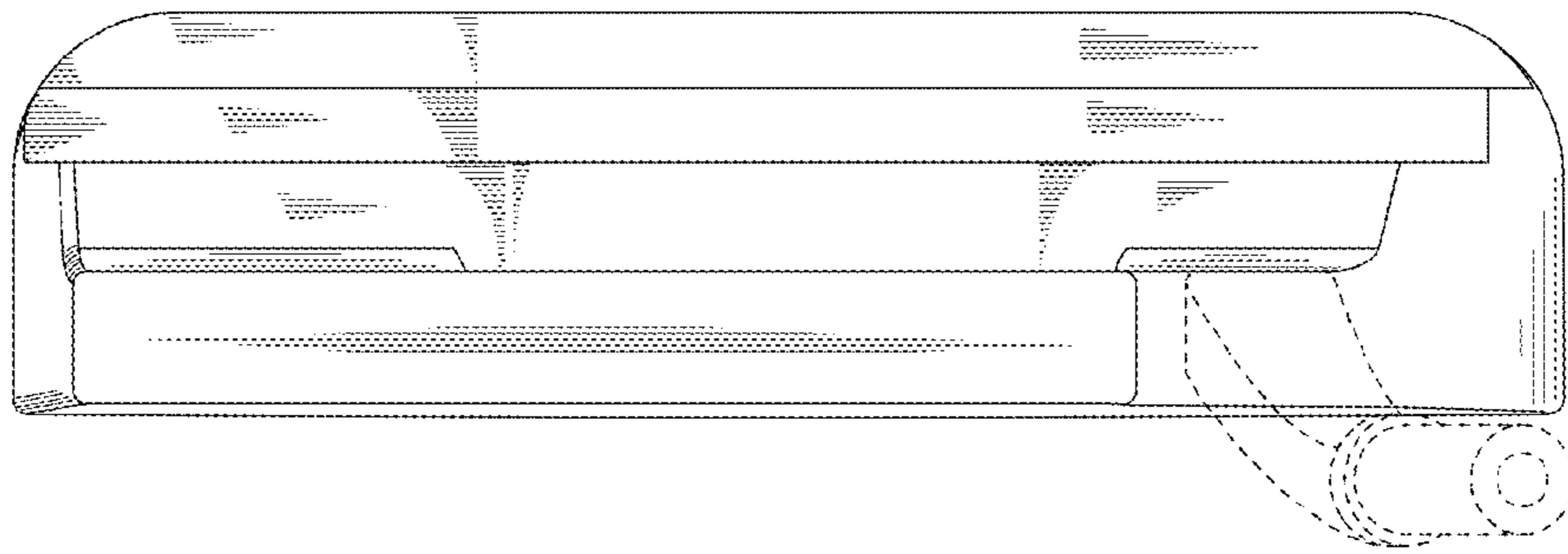

FIG. 5

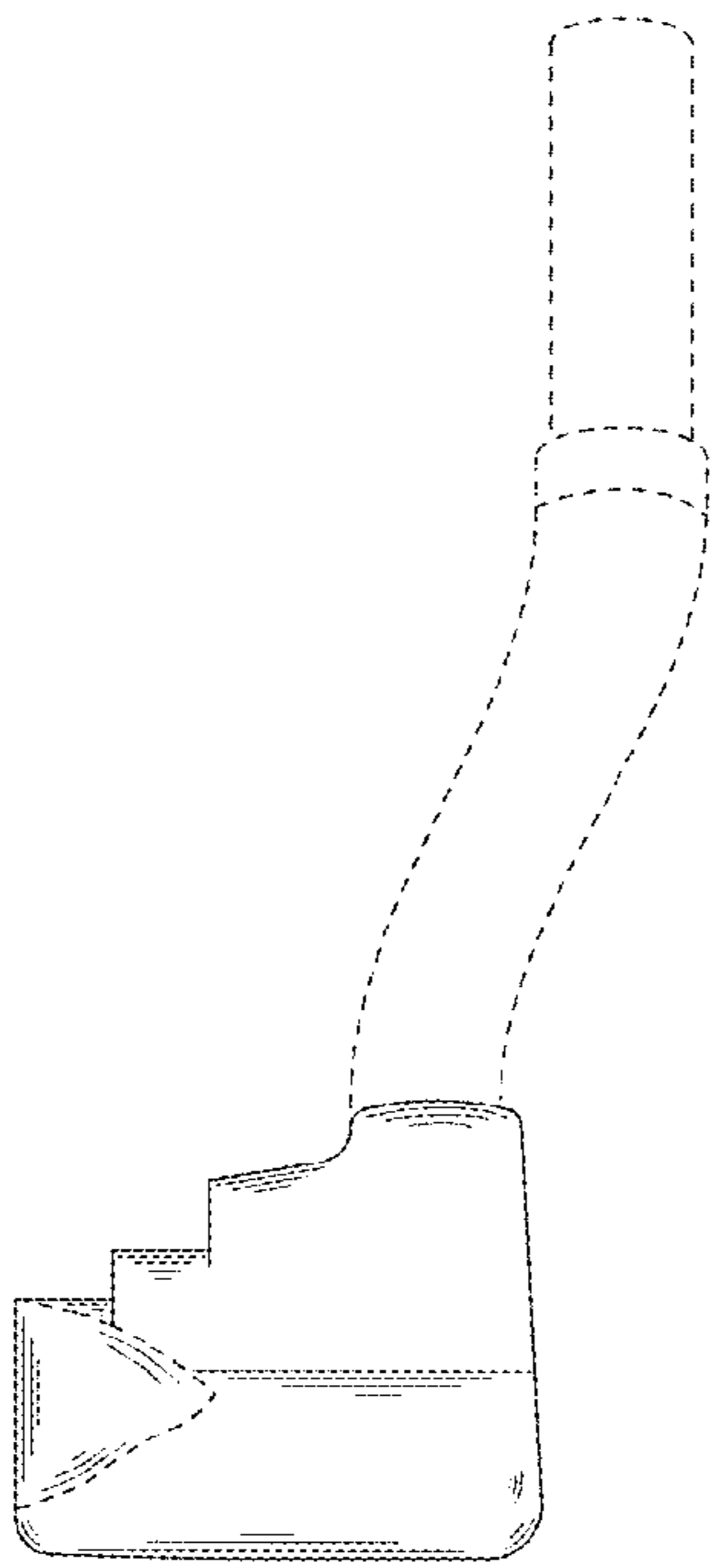

FIG. 6

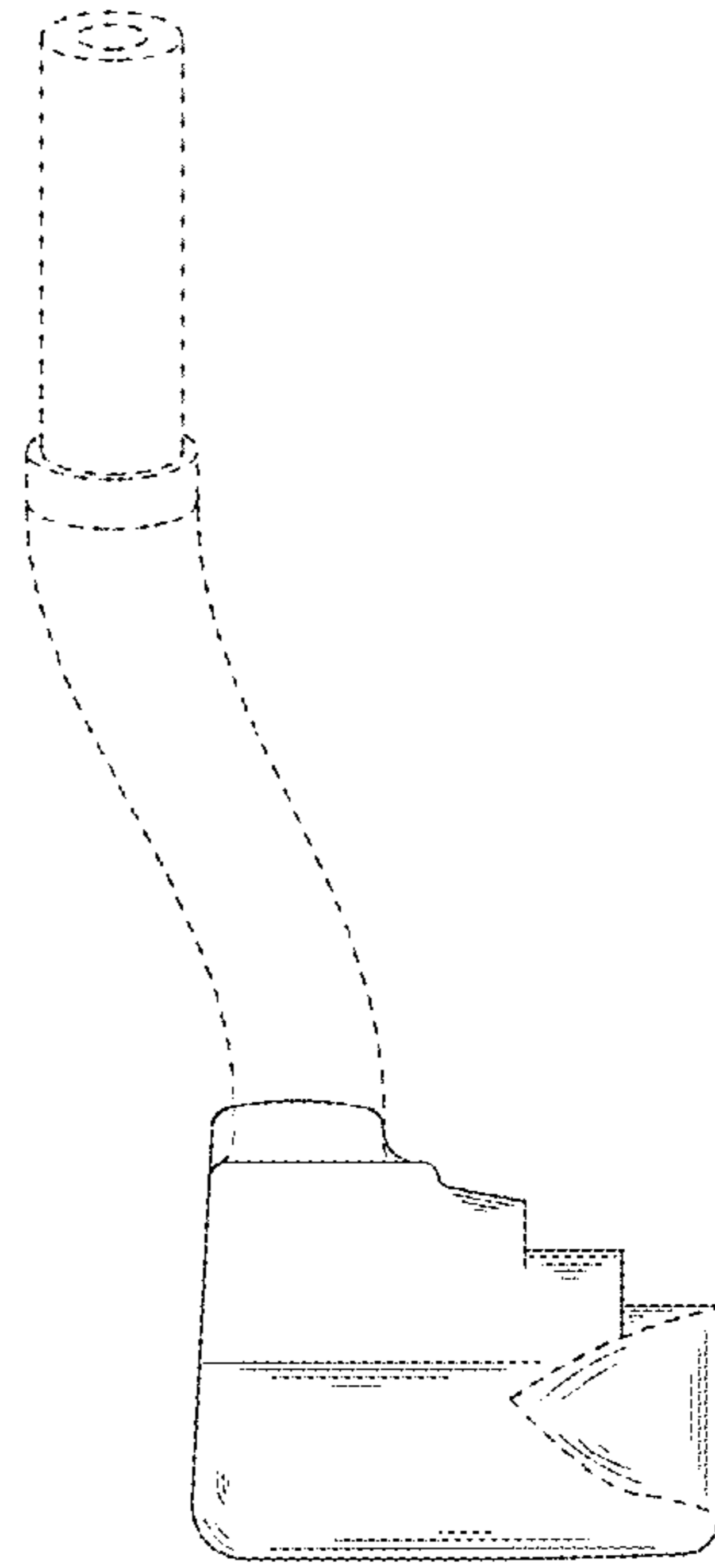

FIG. 7